

iR105

SERVICE MANUAL

REVISION 0

Canon

JULY 2001

FY8-13HF-000

Application

This manual has been issued by Canon Inc. for qualified persons to learn technical theory, installation, maintenance, and repair of products. This manual covers all localities where the products are sold. For this reason, there may be information in this manual that does not apply to your locality.

Corrections

This manual may contain technical inaccuracies or typographical errors due to improvements or changes in products. When changes occur in applicable products or in the contents of this manual, Canon will release technical information as the need arises. In the event of major changes in the contents of this manual over a long or short period, Canon will issue a new edition of this manual.

The following paragraph does not apply to any countries where such provisions are inconsistent with local law.

Trademarks

The product names and company names used in this manual are the registered trademarks of the individual companies.

Copyright

This manual is copyrighted with all rights reserved. Under the copyright laws, this manual may not be copied, reproduced or translated into another language, in whole or in part, without the written consent of Canon Inc.

COPYRIGHT © 2001 CANON INC.

Printed in U.S.A.

Imprimé au U.S.A

Caution

Use of this manual should be strictly supervised to avoid disclosure of confidential information.

1 Symbols Used

This documentation uses the following symbols to indicate special information:

Symbol	Description
	Indicates an item of a non-specific nature, possibly classified as Note, Caution, or Warning.
	Indicates an item requiring care to avoid electric shocks.
	Indicates an item requiring care to avoid combustion (fire).
	Indicates an item prohibiting disassembly to avoid electric shocks or problems.
	Indicates an item requiring disconnection of the power plug from the electric outlet.
 Memo	Indicates an item intended to provide notes assisting the understanding of the topic in question.
 REF.	Indicates an item of reference assisting the understanding of the topic in question.
	Provides a description of a service mode.
	Provides a description of the nature of an error indication.
	Refers to the Copier Basics Series for a better understanding of the contents.



Indicates an item of a non-specific nature, possibly classified as Note, Caution, or Warning.



Indicates an item requiring care to avoid electric shocks.



Indicates an item requiring care to avoid combustion (fire).



Indicates an item prohibiting disassembly to avoid electric shocks or problems.



Indicates an item requiring disconnection of the power plug from the electric outlet.



Memo

Indicates an item intended to provide notes assisting the understanding of the topic in question.



REF.

Indicates an item of reference assisting the understanding of the topic in question.



Provides a description of a service mode.



Provides a description of the nature of an error indication.



Refers to the Copier Basics Series for a better understanding of the contents.

2 Outline of the Manual

This Service Manual provides basic facts and figures about the iR105 and the side paper deck designed as an accessory to the copier; use the information for servicing the machine in the field, thus ensuring the initial product quality.

For the DADF and other accessories, separate service manuals are made available for information, refer to their respective manuals.

This Service Manual consists of the following chapters:

- Chapter 1 Introduction: features, specifications, names of parts, operation of the machine
- Chapter 2 New Functions: differences from the GP605 (iR600) in terms of various mechanisms, disassembly/assembly of mechanical systems
- Chapter 3 Main Controller: outline of the main controller
- Chapter 4 Installation: requirements for the site of installation, installation procedure, relocation procedures, and installation of accessories
- Chapter 5 Maintenance and Inspection: periodically replaced parts, consumables and durables tables, scheduled servicing chart
- Chapter 6 Troubleshooting: standards, adjustments, arrangement of electrical components, troubleshooting image faults, troubleshooting malfunctions, upgrading
- Appendix: general timing chart, general circuit diagram
- Service Modes
- Error Codes

The contents of this Service Manual are subject to change for product improvement, and major changes will be communicated in the form of Service Information bulletins.

All service persons are expected to be familiar with the contents of this Service Manual and the Service Information bulletins, equipping themselves with the ability to isolate and correct possible faults in the machine.

3 iR105 System Configuration

The iR105 may be configured with the following options:

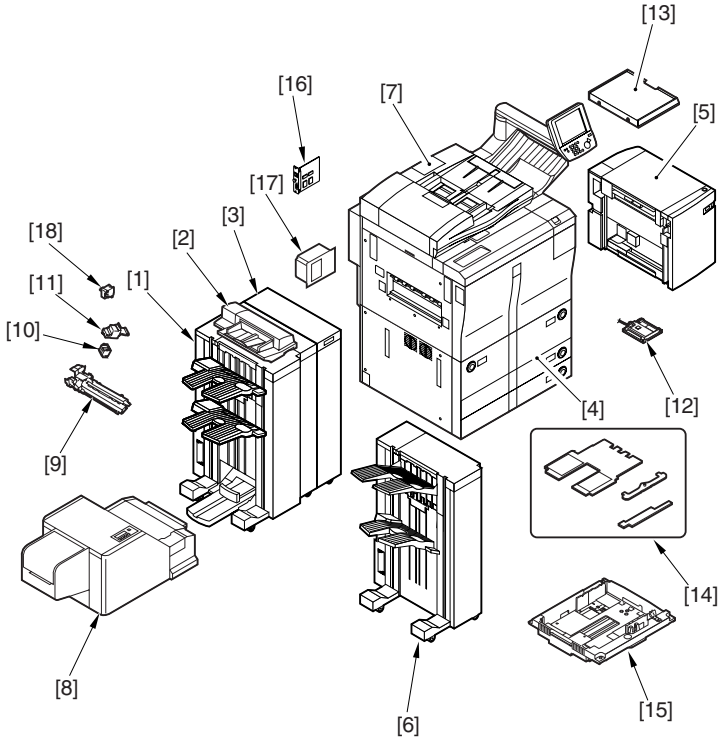

F00-300-01

- | | |
|-----------------------------|--|
| [1] Saddle Finisher-K3N/K4N | [11] Stapler Cartridge-H1 |
| [2] Inserter-B1 | [12] Card Reader-D1 |
| [3] Paper Folding Unit-C1 | [13] Original Holder-D1 |
| [4] iR105 | [14] Index Paper Attachment-A1 |
| [5] Side Paper Deck-N1 | [15] FL Cassette-P4 |
| [6] Finisher-K1N/K2N | [16] Network LIPS Printer Kit |
| [7] DADF-J1 (standard) | [17] NE Controller-A1/Copy Data Controller-B1/B2/Copy Data Controller-A1 |
| [8] Trimmer-A1 | [18] Stapler-D2 |
| [9] Puncher Unit-E1/E2 | |
| [10] Stapler-G1/Stapler-H1 | |

Not all products are necessarily available in all sales areas.



Points to Note When Turning Off the Main Power Switch

Be sure to turn off the main power switch and disconnect the power plug before disassembly work; in addition, keep the following in mind.

1. If you turn off the main power switch while the printer function is in use, the data being processed can be lost. Check to make sure that the Operation/Memory lamp on the control panel is off before operating the main power switch.
2. Do not turn off the main power switch while downloading is taking place; otherwise, the machine may stop operating.
3. If the heater switch is turned on, the cassette heater and the drum heater will remain powered even when the main power switch is turned off.
4. Take care as some components remain powered even when the front cover is opened as long as the main power switch remains on.

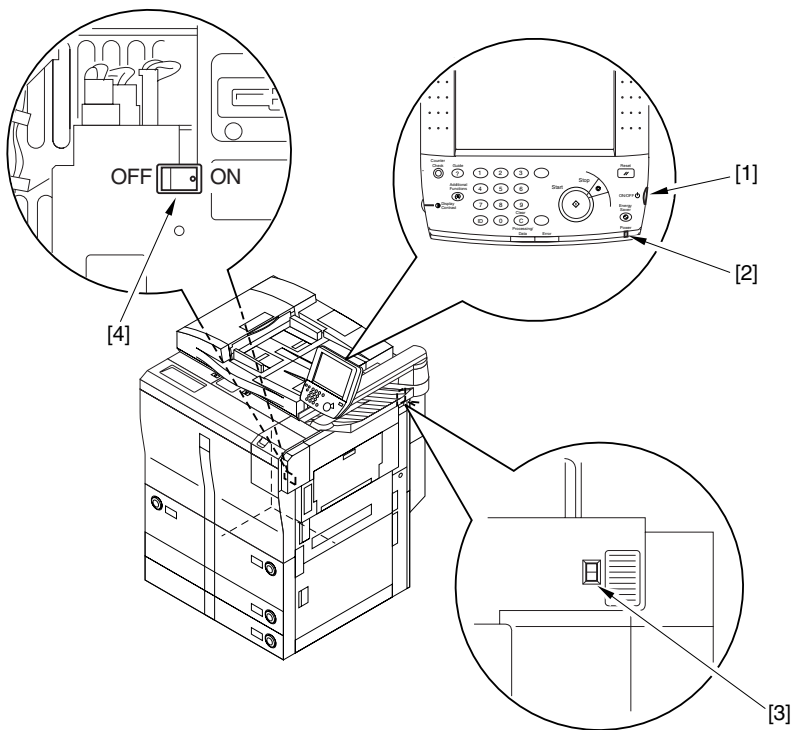

- [1] Control panel power switch
- [2] Operation/Memory lamp

- [3] Main power switch
- [4] Heater switch

F00-300-02

4 Safety

4.1 Safety of Laser Light

Laser light can prove to be harmful to the human body. The machine's laser system, however, is sealed inside a protective housing and external covers to prevent leakage of laser light to its outside, ensuring the safety of the user as long as the machine is used for its intended functions.

4.2 CDRH Ordinances

The Center for Devices and Radiological Health (CDRH) of the US Food and Drug Administration put into force ordinances related to laser products on August 2, 1976.

These ordinances apply to laser products manufactured on and after August 1, 1976, and sale of laser products is prohibited within the US unless they bear a certificate of compliance.

The following is the label that indicates compliance with the CDRH ordinances, and it must be found on all laser products sold in the US.

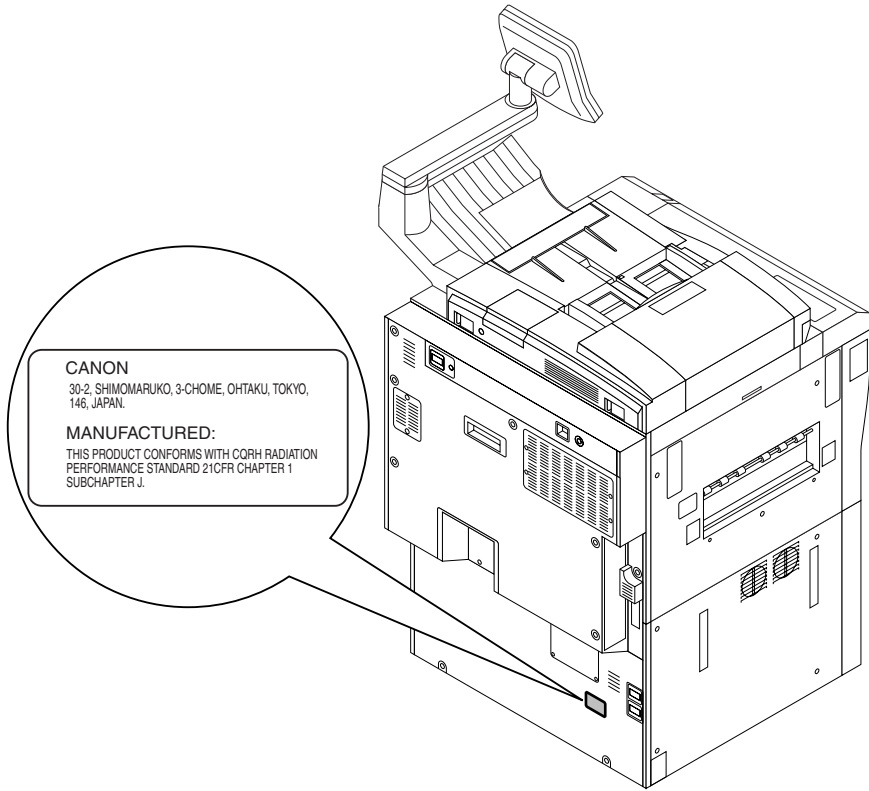

CANON

30-2, SHIMOMARUKO, 3-CHOME, OHTAKU, TOKYO,
146, JAPAN.

MANUFACTURED:

THIS PRODUCT CONFORMS WITH CORH RADIATION
PERFORMANCE STANDARD 21CFR CHAPTER 1
SUBCHAPTER J.

F00-402-01



The description may vary from model to model.

4.3 Handling the Laser System

You must take extra care when servicing the area around the machine's laser system, as by not bringing a high-reflectance screwdriver into the laser path.

Take such precautions as removing the watch and rings before starting the work (to prevent reflection of laser light to the eye).

The machine's laser light is red, and covers that can reflect laser light are identified by the following label. Take full care whenever servicing areas of the machine behind these covers.



This label is attached to all covers inside the machine where hazards from laser light exist.

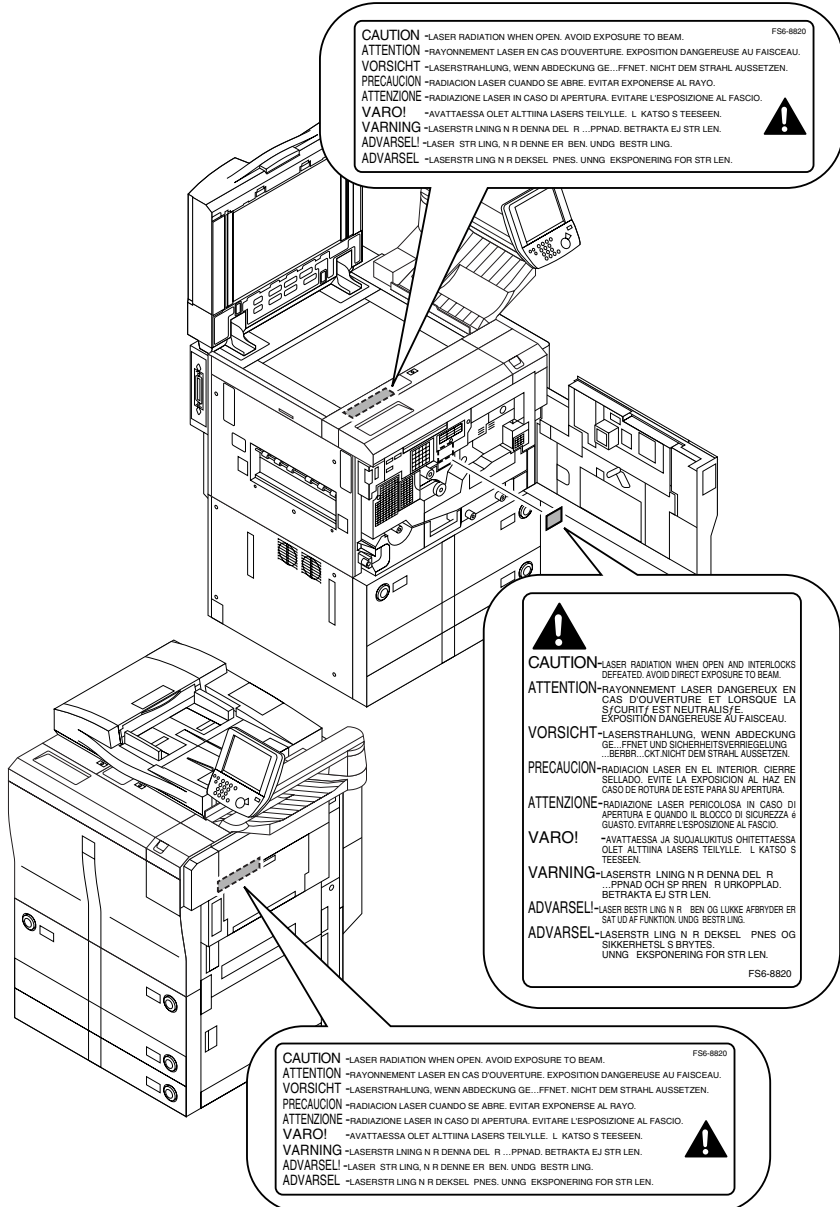

FS6-8820

CAUTION -LASER RADIATION WHEN OPEN. AVOID EXPOSURE TO BEAM.
ATTENTION -RAYONNEMENT LASER EN CAS D'OUVERTURE. EXPOSITION DANGEREUSE AU FAISCEAU.
VORSICHT -LASERSTRAHLUNG, WENN ABDECKUNG GE...FFNET. NICHT DEM STRAHL AUSSETZEN.
PRECAUCION -RADIACION LASER CUANDO SE ABRE. EVITAR EXPONERSE AL RAYO.
ATTENZIONE -RADIAZIONE LASER IN CASO DI APERTURA. EVITARE L'ESPOSIZIONE AL FASCIO.
VARO! -AVATTAESSA OLET ALTHINA LASERS TEIYLLE. L. KATSO S TEESEEN.
WARNING -LASERSTR LNING N R DENNA DEL R ...PPNAD. BETRAKTA EJ STR LEN.
ADVARSEL! -LASER STR LING N R DENNE ER BEN. UNDG BESTR LING.
ADVARSEL -LASERSTR LING N R DEKSEL. PNES. UNNG EKSPONERING FOR STR LEN.

FS6-8820

CAUTION-LASER RADIATION WHEN OPEN AND INTERLOCKS DEFATED. AVOID DIRECT EXPOSURE TO BEAM.
ATTENTION-RAYONNEMENT LASER DANGEREUX EN CAS D'OUVERTURE ET LORSQUE LA SECURITE EST NEUTRALISEE. EXPOSITION DANGEREUSE AU FAISCEAU.
VORSICHT-LASERSTRAHLUNG, WENN ABDECKUNG GE...FFNET UND SICHERHEITSVERREGELUNG ...BERBR...CHT NICHT DEM STRAHL AUSSETZEN.
PRECAUCION-RADIACION LASER EN EL INTERIOR. CIERRE SELLADO. EVITE LA EXPOSICION AL HAZ EN CASO DE ROTURA DE ESTE PARA SU APERTURA.
ATTENZIONE-RADIAZIONE LASER PERICOLOSA IN CASO DI APERTURA E QUANDO IL BLOCCO DI SICUREZZA E' GUASTO. EVITARE L'ESPOSIZIONE AL FASCIO.
VARO! -AVATTAESSA JA SUOJALUKTUS OHTETTAESSA OLET ALTHINA LASERS TEIYLLE. L. KATSO S TEESEEN.
WARNING -LASERSTR LNING N R DENNA DEL R ...PPNAD OCH SP PREN R URKOPPLAD. BETRAKTA EJ STR LEN.
ADVARSEL! -LASER BESTR LING N R BEN OG LUKKE AFRYDER ER SAT UD AF FUNKTION UNDG BESTR LING.
ADVARSEL -LASERSTR LING N R DEKSEL. PNES OG SIKKERHETS S BRYTES. UNNG EKSPONERING FOR STR LEN.

FS6-8820

FS6-8820

CAUTION -LASER RADIATION WHEN OPEN. AVOID EXPOSURE TO BEAM.
ATTENTION -RAYONNEMENT LASER EN CAS D'OUVERTURE. EXPOSITION DANGEREUSE AU FAISCEAU.
VORSICHT -LASERSTRAHLUNG, WENN ABDECKUNG GE...FFNET. NICHT DEM STRAHL AUSSETZEN.
PRECAUCION -RADIACION LASER CUANDO SE ABRE. EVITAR EXPONERSE AL RAYO.
ATTENZIONE -RADIAZIONE LASER IN CASO DI APERTURA. EVITARE L'ESPOSIZIONE AL FASCIO.
VARO! -AVATTAESSA OLET ALTHINA LASERS TEIYLLE. L. KATSO S TEESEEN.
WARNING -LASERSTR LNING N R DENNA DEL R ...PPNAD. BETRAKTA EJ STR LEN.
ADVARSEL! -LASER STR LING N R DENNE ER BEN. UNDG BESTR LING.
ADVARSEL -LASERSTR LING N R DEKSEL. PNES. UNNG EKSPONERING FOR STR LEN.

F00-403-01

4.4 Safety of Toner

The machine's toner is a non-toxic product consisting of plastic, iron, and small amounts of dyes.

If your skin or clothes have come into contact with toner, try removing as much of it as possible with dry paper tissues, and wash off with water. (Do not use warm water, as it would turn the toner jelly-like and become fused with the fibers of the fabric.)

In addition, avoid bringing toner into contact with plastic material, as it tends to dissolve easily.



Do not throw toner into fire to avoid explosion.

Contents

CHAPTER 1 INTRODUCTION

1 Features	1-1	2.1 Copier	1-3
1.1 High Speed, High Quality	1-1	2.1.1 Type	1-3
1.2 High Durability, High Reliability	1-1	2.1.2 System	1-3
1.3 High-Performance Controller, Large-Capacity Hard Disk	1-1	2.1.3 Functions	1-4
1.4 Ease of Operation	1-1	2.1.4 Others	1-11
1.5 Large-Capacity Paper Source	1-1	2.2 Side Paper Deck-N1	1-14
1.6 Various Delivery Processing (with options)	1-2	3 Names of Parts	1-15
1.7 High-Level Printer Functions to Support Networking Requirements	1-2	3.1 External View	1-15
2 Specifications	1-3	3.2 Cross Section	1-18
		4 Operation	1-20
		4.1 Power Switch	1-20
		4.2 Control Panel	1-21
		4.3 Extension Mode Items	1-22
		4.4 User Mode	1-23

CHAPTER 2 NEW FUNCTION

1 Basic Construction	2-1	2.9.2 Scanner Drive Assembly	2-17
1.1 Outline of the Basic Construction	2-1	2.9.3 PCBs	2-24
1.2 Wiring Diagram of the Major PCBs	2-2	2.9.4 Others	2-29
2 Original Exposure System	2-3	3 Image Processing System	2-37
2.1 Outline of the Original Exposure System	2-3	3.1 Outline of the Image Processing System	2-37
2.2 Changes Made to the Original Exposure System	2-4	3.2 Changes Made to the Image Processing System	2-38
2.3 Enlargement/Reduction	2-5	3.3 4-Channel High-Speed Reading CCD	2-39
2.4 Preventing Overheating of the Scanner Motor	2-6	3.4 CCD Adjustment	2-40
2.5 Arrangement of PCBs	2-7	3.5 Analog Image Processing	2-41
2.6 Stabilizing the Scanning Lamp	2-8	3.6 Digital Image Processing	2-42
2.7 Detecting the State (open/closed) of the ADF	2-8	3.7 Detecting the Orientation of Originals	2-43
2.8 Detecting Dust in Stream Reading	2-10	3.8 Disassembly/Assembly	2-44
2.9 Disassembly/Assembly	2-12	3.8.1 CCD Unit	2-45
2.9.1 No. 1 Mirror Base Assembly	2-13	3.8.2 Hard Disk	2-47
		4 Laser Exposure System	2-51
		4.1 Outline of the Laser Exposure System	2-51
		4.2 Changes Made to the Laser Exposure System	2-53

4.3	Disassembly/Assembly	2-54	6.6.6	Others	2-103
4.3.1	Laser Unit	2-55	7	Fixing System	2-105
4.3.2	BD Unit	2-56	7.1	Outline of the Fixing System	2-105
5	Image Formation System	2-59	7.2	Changes Made to the Fixing System	2-107
5.1	Outline of the Image Formation System	2-59	7.3	Fixing Temperature Control ...	2-109
5.2	Changes Made to the Image Formation System	2-61	7.4	Transparency Mode	2-110
5.3	Addition of the Pre-Transfer Exposure LED	2-62	7.5	Thick Paper Mode	2-111
5.4	Measures Against Overheating of the Developing Unit	2-62	7.6	Power Save Mode	2-112
5.5	Addition of the Developing Fan	2-62	7.7	Detecting an Error	2-113
5.6	Modifying the Developing Cylinder Cover	2-63	7.8	Down Sequence Control	2-114
5.7	Preventing Adhesion of Toner to the Cleaning Blade	2-64	7.9	Disassembly/Assembly	2-115
5.8	Disassembly/Assembly	2-65	7.9.1	Fixing Heater and the Control Parts	2-116
5.8.1	Process Unit	2-66	7.9.2	Fixing Roller Assembly ...	2-122
5.8.2	Drum Cleaner Unit	2-71	7.9.3	Delivery Assembly	2-125
5.8.3	Charging Wires	2-74	7.9.4	Paper Sensors	2-128
5.8.4	Area Around the Process Unit	2-80	8	Externals/Auxiliary Controls	2-131
6	Pickup/Feeding System	2-83	8.1	Changes Made to Externals/Auxiliary Controls	2-131
6.1	Outline of the Pickup/Feeding System	2-83	8.2	Fans	2-132
6.2	Changes Made to the Pickup/Feeding System	2-84	8.3	Sequence of Fan Operation ...	2-134
6.3	Optical Sensors	2-86	8.4	Disassembly/Assembly	2-136
6.4	Image Write Start Sensor	2-86	8.4.1	External Covers	2-137
6.5	Index Paper Attachment	2-88	8.4.2	Control Panel	2-145
6.6	Disassembly/Assembly	2-89	8.4.3	Fans	2-153
6.6.1	Manual Feed Tray Assembly	2-90	8.4.4	Drive Assembly	2-166
6.6.2	Cassette Pickup Assembly	2-94	8.4.5	Switches	2-170
6.6.3	Vertical Path Roller Assembly	2-96	8.4.6	PCBs	2-172
6.6.4	Registration Feed Assembly	2-99	8.4.7	Others	2-184
6.6.5	Duplex Unit	2-100	9	Side Paper Deck-N1	2-187
			9.1	Outline of the Side Paper Deck	2-187
			9.2	Changes made to the Side Paper Deck	2-189
			9.3	Optical Sensors	2-190
			9.4	Disassembly/Assembly ...	2-191
			9.4.1	Removing the Deck Pickup Sensor Unit	2-192
			9.4.2	Removing the Deck Feed Sensor Unit	2-193

CHAPTER 3 MAIN CONTROLLER

1 Basic Operation	3-1	2.3.2 SDRAM	3-10
1.1 Functional Construction	3-1	2.4 Output Image Processing	3-11
1.2 Outline of the Electrical Circuitry	3-2	2.4.1 Smoothing	3-11
1.2.1 Outline	3-2	2.4.2 Thickening (PDL output only)	3-11
1.2.2 Main Controller PCB	3-2	2.4.3 Binary-Binary Conversion (read image output only) ...	3-11
1.2.3 Hard Disk Drive	3-2	3 Soft Counters	3-12
1.3 Start-Up Sequence	3-4	4 Controlling the Power Supply	3-14
1.3.1 Outline	3-4	4.1 Outline	3-14
1.3.2 Start-Up Sequence	3-5	4.2 Power Supply Mode	3-14
1.3.3 Construction of the System Software	3-6	4.3 Standby Mode (normal operation)	3-14
1.4 Inputs/Outputs the Major PCBs	3-7	4.4 Power Save Mode	3-14
1.4.1 Connection Diagram of the Major PCBs	3-7	4.5 Low Power Mode	3-15
2 Digital Image Processing	3-8	4.5.1 Shift from Standby Mode (standby → low power)	3-15
2.1 Outline	3-8	4.5.2 Shift to Standby Mode (low power → standby)	3-15
2.2 Input Image Processing	3-9	4.6 Sleep Mode	3-15
2.2.1 Image Data from the Reader Unit	3-9	4.6.1 Shift from Standby Mode (standby → sleep)	3-15
2.2.2 Enlargement/Reduction (main scanning direction)	3-9	4.6.2 Shift from Low-Power Mode (low power → sleep)	3-15
2.2.3 Edge Emphasis	3-9	4.6.3 Return to Standby Mode (sleep → standby)	3-15
2.2.4 Edit Processing	3-9	4.7 OFF Mode	3-16
2.2.5 Density Conversion (LUT)	3-9	4.7.1 Shift from Standby Mode (standby → OFF mode)	3-16
2.2.6 Binary Processing (error diffusion method T-BIC)	3-9	4.7.2 Shift from Low-Power Mode (low-power → OFF mode)	3-16
2.2.7 Binary (dither screen method)	3-10	4.7.3 Return to Standby Mode (OFF mode → standby)	3-16
2.3 Controlling the Image Memory	3-10	4.8 Power Supply OFF Mode	3-16
2.3.1 Compression/Expansion, Rotation, and Enlargement/ Reduction	3-10		

CHAPTER 4 INSTALLATION

1	Selecting the Site	4-1	2.11	Cassette	4-32
2	Unpacking and Installation	4-4	2.12	Index Paper Attachment	4-33
	2.1 Points to Note Before Starting the Work	4-4	2.13	Attaching the Labels, Setting Paper, Checking Images/Operations, and User Mode	4-34
	2.1.1 Attachments	4-5	2.14	Changing the Paper Size for the Front Deck (right, left)	4-38
	2.2 Unpacking	4-6	3	Relocating the Machine	4-40
	2.3 Mounting the Scanner	4-11	4	Installing the Card Reader-D1	4-41
	2.4 Installing the Fixing Assembly	4-12	4.1	Installing the Card Reader-D1	4-41
	2.5 Mounting the Charging Assemblies	4-14	5	Installing the NE Controller-A1/ NE Controller-B1/Copy Data Controller-A1	4-46
	2.6 Checking the Developing Assembly	4-19	5.1	Installing the NE Controller-A1/ NE Controller-B1/Copy Data Controller-A1	4-46
	2.7 Mounting the Pickup Assembly	4-21			
	2.8 Mounting the Control Panel	4-23			
	2.9 Supplying the Toner	4-29			
	2.10 Mounting the ADF	4-31			

CHAPTER 5 MAINTENANCE AND INSPECTION

1	Periodically Replaced Parts	5-1	4	Scheduled Service Items	5-12
2	Guide to Replacement of Durables	5-3	4.1	Copier	5-12
	2.1 Copier	5-3	4.2	Scheduled Service Work	5-16
	2.2 Side Paper Deck	5-7	4.2.1	Work 1	5-16
3	Scheduled Service Chart	5-8	4.2.2	Work 2	5-19

CHAPTER 6 TROUBLESHOOTING

1	Guide to the Troubleshooting Tables	6-1	2.1.1	Adjusting the Image Position for Printer Output	6-9
	1.1 Image Adjustment Basic Procedure	6-3	2.1.2	Adjusting the Image Position of Copier Output (book mode)	6-14
	1.1.1 Making Pre-Checks	6-3	2.1.3	Adjusting the Image Position of Copier Output (ADF mode)	6-17
	1.1.2 Making Checks on the Printer Side (1/2)	6-4	2.2	Scanning System	6-18
	1.1.3 Making Checks on the Printer Side (2/2)	6-5	2.2.1	Replacing the Scanner Drive Cable	6-18
	1.1.4 Making Checks on the Scanner Side	6-6	2.2.2	Adjusting the Scanner Mirror Base	6-18
2	Standards and Adjustments	6-9			
	2.1 Image Adjustment-Related Items	6-9			

2.2.3	When Replacing the Standard White Plate ...	6-18	2.4.12	Position the Fixing/ Feeder Unit Locking Solenoid (SL4)	6-30
2.2.4	When Replacing the Scanning Lamp	6-18	2.4.13	Position of the Multifeed Latch Solenoid (SL6)	6-31
2.3	Image Formation System	6-19	2.4.14	Position of the Deck (right) Pickup Solenoid (SL7)	6-32
2.3.1	Stringing the Grid Wire of the Primary Charging Assembly	6-19	2.4.15	Position of the Deck (Left) Pickup Solenoid (SL8)	6-33
2.3.2	Stringing the Charging Wire of the Charging Assemblies	6-19	2.4.16	Position of the Cassette 3/4 Pickup Solenoid (SL9/10)	6-34
2.3.3	Mounting the Drum Cleaning Blade	6-19	2.4.17	Position of the Side Paper Deck Pickup Roller Releasing Solenoid	6-35
2.4	Pickup/Feeding System	6-20	2.4.18	Fitting the Side Guide Timing Belt of the Manual Feed Tray Assembly	6-35
2.4.1	Orientation of the Deck/ Cassette Pickup Roller	6-20	2.4.19	Fitting the Drive Belt	6-36
2.4.2	Orientation of the Deck/ Cassette Separation Roller ..	6-21	2.5	Fixing System	6-37
2.4.3	Orientation of the Feeding Roller of the Deck/Cassette Pickup Assembly	6-21	2.5.1	Points to Note When Mounting the Fixing Heater	6-37
2.4.4	Orientation of the Pickup Roller of the Manual Feed Tray/Side Paper Deck	6-22	2.5.2	Adjusting the Lower Roller Pressure (nip)	6-38
2.4.5	Orientation of the Feeding Roller of the Manual Feed Tray	6-23	2.6	Laser Exposure System	6-39
2.4.6	Orientation of the Feeding Roller of the Side Paper Deck	6-23	2.6.1	When Replacing the Laser Unit	6-39
2.4.7	Adjusting the Pressure of the Deck/Cassette Separation Roller	6-24	2.6.2	Checking the Laser Power	6-39
2.4.8	Adjusting the Pressure of the Pickup/Feeding Roller of the Manual Feed Tray	6-25	2.7	Electrical Parts-Related Items	6-42
2.4.9	Locations of the Solenoid	6-26	2.7.1	Electrical Parts Requiring Work After Replacement ...	6-42
2.4.10	Location of the Fixing Web Solenoid (SL2)	6-27	2.7.2	When Replacing the Scanning Lamp	6-42
2.4.11	Position of the Delivery Flapper Solenoid (SL3)	6-29	2.7.3	When Replacing the CCD Unit	6-42
			2.7.4	When Replacing Reader Controller PCB	6-42
			2.7.5	When Replacing the Main Controller PCB	6-42

2.7.6	When Replacing the HDD Unit	6-42	3.3.2	The output is too light (solid black area)	6-72
2.7.7	When Replacing the DC Controller PCB	6-42	3.3.3	The output is too light (overall, considerably)	6-72
2.7.8	When Replacing the HV-DC PCB	6-42	3.3.4	The output has uneven density (darker at the front)	6-74
2.7.9	When Replacing the Laser Unit	6-42	3.3.5	The output has uneven density (lighter at the front)	6-74
2.7.10	When Replacing the Potential Sensor/ Potential Control PCB	6-43	3.3.6	The output is foggy (overall)	6-75
2.7.11	Checking the Surface Potential Control System ...	6-47	3.3.7	The output has vertical fogging	6-76
2.8	Potential Control System Conversion Table	6-53	3.3.8	The output has black lines (vertical, fuzzy, thick)	6-76
2.9	Checking the Environment Sensor	6-57	3.3.9	The output has black lines (vertical, fine)	6-77
2.10	Checking the Photointerrupters	6-58	3.3.10	The output has white spots (vertical)	6-78
2.11	Checking the Optical Sensors	6-64	3.3.11	The output has white lines (vertical)	6-78
3	Troubleshooting Image Faults	6-65	3.3.12	The output has white spots (horizontal)	6-80
3.1	Making Initial Checks	6-65	3.3.13	The back of the output is soiled	6-81
3.1.1	Checking the Side of Installation	6-65	3.3.14	The output has a fixing fault	6-81
3.1.2	Checking the Originals	6-65	3.3.15	The output has a displaced leading edge (considerably large margin)	6-82
3.1.3	Checking the Copyboard Cover, Copyboard Glass, and Standard White Plate	6-66	3.3.16	The output has a displaced leading edge (large margin)	6-82
3.1.4	Checking the Charging Assemblies	6-66	3.3.17	The output has a displaced leading edge (no margin)	6-82
3.1.5	Checking the Developing Assembly	6-66	3.3.18	The output is blurred	6-83
3.1.6	Checking the Paper	6-66	3.3.19	The output has horizontal fogging	6-84
3.1.7	Checking the Periodically Replaced Parts	6-66	3.3.20	The output has poor sharpness	6-84
3.1.8	Others	6-67	3.3.21	The output is solid blank ...	6-85
3.2	Sample Faulty Images	6-70	3.3.22	The output is solid black ...	6-86
3.3	Troubleshooting Image Faults	6-71			
3.3.1	The output is too light (halftone area)	6-71			

4 Troubleshooting Malfunctions	6-87	4.1.38 E243	6-106
4.1 Troubleshooting by		4.1.39 E251	6-106
Malfunction	6-87	4.1.40 E302	6-107
4.1.1 E000	6-87	4.1.41 E315	6-107
4.1.2 E001	6-88	4.1.42 E320	6-107
4.1.3 E002	6-89	4.1.43 E400	6-108
4.1.4 E003	6-89	4.1.44 E402	6-108
4.1.5 E004	6-89	4.1.45 E404	6-110
4.1.6 E005	6-90	4.1.46 E405	6-111
4.1.7 E010	6-90	4.1.47 E410	6-112
4.1.8 E012	6-91	4.1.48 E422	6-113
4.1.9 E013	6-91	4.1.49 E601	6-114
4.1.10 E014	6-92	4.1.50 E602	6-114
4.1.11 E015	6-92	4.1.51 E676	6-115
4.1.12 E019	6-93	4.1.52 E677	6-115
4.1.13 E020	6-93	4.1.53 E710-0001 (reader	
4.1.14 E025	6-94	controller), E710-002	
4.1.15 E032	6-94	(DC controller), E710-	
4.1.16 E043	6-94	0003 (main controller)	6-115
4.1.17 E051	6-95	4.1.54 E711-0001 (reader	
4.1.18 E065	6-96	controller), E711-0002	
4.1.19 E067	6-97	(DC controller), E711-	
4.1.20 E068	6-98	0003 (main controller)	6-115
4.1.21 E069	6-100	4.1.55 E712	6-116
4.1.22 E100	6-101	4.1.56 E713	6-116
4.1.23 E110	6-101	4.1.57 E717	6-117
4.1.24 E111	6-102	4.1.58 E732	6-117
4.1.25 E121-0001	6-102	4.1.59 E733	6-117
4.1.26 E121-0002	6-103	4.1.60 E737	6-118
4.1.27 E202 (The keys in		4.1.61 E740	6-118
the control panel are		4.1.62 E741	6-118
locked.)	6-103	4.1.63 E744	6-119
4.1.28 E204 (The keys in		4.1.64 E800	6-119
the control panel are		4.1.65 E804	6-120
locked.)	6-104	4.1.66 E805	6-120
4.1.29 E211	6-104	4.1.67 E820	6-121
4.1.30 E215	6-104	4.1.68 E823	6-121
4.1.31 E218	6-104	4.1.69 E824	6-122
4.1.32 E219	6-105	4.1.70 E830	6-122
4.1.33 E220	6-105	4.1.71 AC power is absent	6-123
4.1.34 E222	6-105	4.1.72 The DC power supply	
4.1.35 E226	6-105	fails to operate. 1	6-124
4.1.36 E240	6-105	4.1.73 Pickup fails	6-125
4.1.37 E241	6-106		

4.1.74	The lifter fails to move up	6-127	4.1.93	The deck lifter fails to move up (side paper deck)	6-142
4.1.75	The lifter fails to move up (pickup from cassette)	6-128	5	Troubleshooting Feeding Problems	6-143
4.1.76	Pickup fails (multifeeder)	6-129	5.1	Copy Paper Jams	6-143
4.1.77	The vertical path roller fails to rotate	6-131	5.1.1	Pickup Assembly	6-144
4.1.78	The registration roller fails to rotate	6-133	5.1.2	Separation/Feeding Assembly	6-145
4.1.79	The No. 1 mirror base fails to move	6-134	5.1.3	Fixing Assembly, Delivery Assembly	6-146
4.1.80	The pre-exposure lamp fails to go ON	6-135	5.1.4	Fixing assembly, Delivery assembly (reversal delivery assembly)	6-147
4.1.81	The scanning lamp fails to go ON	6-135	5.1.5	Cleaner assembly	6-147
4.1.82	The toner feed motor (M6) inside the cartridge fails to operate	6-136	5.1.6	Lower Feeding Assembly	6-148
4.1.83	The feed motor (M18) inside the hopper fails to operate	6-136	5.2	Feeding Faults	6-149
4.1.84	The drum heater fails to operate	6-137	5.2.1	Double Feeding	6-149
4.1.85	The Add Toner message fails to go ON	6-137	5.2.2	Wrinkles	6-149
4.1.86	The Add Toner message fails to go ON	6-138	6	Arrangement and Function of Electrical Parts	6-150
4.1.87	The Set Card Reader message fails to go ON	6-138	6.1	Clutches	6-150
4.1.88	The Set Control Card message fails to go OFF	6-138	6.2	Solenoids	6-152
4.1.89	The Add Paper message fails to go OFF (deck light/left)	6-139	6.3	Motors	6-154
4.1.90	The Add Paper message fails to go OFF (cassette 3/4)	6-139	6.4	Fans	6-156
4.1.91	The fixing heater fails to operate	6-140	6.5	Sensor 1	6-158
4.1.92	Pickup fails (side paper deck)	6-141	6.6	Sensor 2	6-160
			6.7	Switches	6-162
			6.8	Counters, There, Fuses, and Others	6-164
			6.9	PCBs	6-166
			6.10	Side Paper Deck-N1	6-168
			6.11	Variable Resistors (VR), Light-Emitting Diodes (LED), and Check Pins by PCB	6-170
			6.11.1	Main Controller PCB	6-170
			6.11.2	Reader Controller PCB	6-171
			6.11.3	DC controller PCB	6-171
			6.11.4	HV-DC PCB	6-172
			7	Upgrading	6-173
			7.1	Outline	6-173

7.1.1	Download Mode	6-173	7.5.2	Starting Formatting	6-192
7.1.2	Making Pre-Checks	6-174	7.5.3	Points to Note When Formatting the Hard Disk	6-198
7.2	Data Control	6-177	7.6	Upgrading by Replacing the DIMM/ROM	6-199
7.3	Downloading the System Software, RUI, and Language Module	6-180	8	Backing Up Data	6-201
7.3.1	Making Connections	6-180	8.1	Outline	6-201
7.3.2	Downloading	6-180	8.2	Backing Up Data	6-202
7.3.3	After Downloading	6-186	8.2.1	Making Preparations	6-202
7.4	Upgrading the BOOT ROM ...	6-186	8.2.2	Making Connections	6-202
7.4.1	Making Preparations	6-186	8.2.3	Backing Up Data	6-203
7.4.2	Connection	6-187	8.2.4	Downloading Backup Data	6-208
7.4.3	Preparing BOOT ROM ...	6-187	8.2.5	Managing Backup Data ...	6-212
7.4.4	After Downloading	6-191			
7.5	Formatting the HDD	6-192			
7.5.1	Making Connections	6-192			

APPENDIX

1	GENERAL TIMING CHART	A-1	3	GENERAL CIRCUIT DIAGRAM ...	A-7
2	LIST OF SIGNALS/ ABBREVIATIONS	A-3	4	Special Tools Table	A-11
			5	Solvents/Oils	A-14

SERVICE MODE

1	Construction of Service Mode	S-1	2.4	FUNCTION	S-72
1.1	Outline	S-1	2.5	OPTION	S-90
1.2	Starting Service Mode and Making Selections	S-2	2.6	TEST	S-110
1.3	Ending Service Mode	S-3	2.7	COUNTER	S-117
1.4	Backing Up Service Mode Settings	S-3	3	FEEDER	S-123
1.5	Using Service Mode	S-4	3.1	DISPLAY	S-123
1.5.1	Initial Screen	S-4	3.2	ADJUST	S-123
1.5.2	Level 1/2 Screen	S-4	3.3	FUNCTION	S-125
1.5.3	Level 3 Screen	S-5	3.4	OPTION	S-126
2	COPIER	S-6	4	SORTER	S-127
2.1	DISPLAY	S-6	4.1	ADJUST	S-127
2.2	I/O	S-25	4.2	OPTION	S-128
2.3	ADJUST	S-55	5	BOARD	S-129
			5.1	OPTION	S-129

ERROR CODE

1	Error Codes	E-1	1.1	Outline of Error Codes	E-1
---	-------------------	-----	-----	------------------------------	-----

CHAPTER 1

INTRODUCTION

1 Features

1.1 High Speed, High Quality

- The use of a high-speed engine based on a twin-laser exposure technology promises high-speed operation and high-quality image reproduction.
- The CCD is a 4-channel CCD.
- Operating Speed:
105 copies/min (A4/LTR, 1-to-N; from cassette/deck)
- Reading Resolution: 600 × 600 dpi
- Printing Resolution
Copier mode: 1200 (equivalent) × 600 dpi (with smoothing ON)
Printer mode: 2400 (equivalent) × 600 dpi

1.2 High Durability, High Reliability

- The machine is designed for high durability and high reliability, as by using an amorphous silicon photosensitive drum.

1.3 High-Performance Controller, Large-Capacity Hard Disk

- The machine uses an iR controller (mounted on the main controller) for parallel processing of multiple tasks, thereby ensuring highly efficient control and extremely high speed data processing.
- The machine comes with a built-in large-capacity of hard disk (10 GB). When used as image memory, it enables memory sorting.
- The Box function makes storage of large volumes of data possible.

1.4 Ease of Operation

- The large-size, high-resolution, upright LCD color touch panel (1/1VGA) offers a high degree of recognition.

1.5 Large-Capacity Paper Source

- Addition of options will make a source of paper capable of accommodating as many as 7,650 sheets (80 g/m² paper):

Right deck:	1500 sheets (1700 sheets)*
Left deck:	1500 sheets (1700 sheets)*
Cassette 3:	550 sheets (600 sheets)*
Cassette 4:	550 sheets (600 sheets)*
Manual feed tray:	50 sheets
Side Paper Deck-N1 (option):	3500 sheets (4000 sheets)*

* The number in parentheses indicates when the count is based on 64 g/m² paper.

1.6 Various Delivery Processing (with options)

a. Stapling

- A stack of as many as 100 sheets may be stapled.(1-point or 2-point stapling; with a Finisher-K1N/K2N or Saddle Finisher-K3N/K4N in use)



100-sheet stapling:	Stapler-G1 Stapler cartridge (standard with finisher)
50-sheet stapling:	Stapler-H1 Stapler Cartridge -H1

b. Saddle Stitching

- A sheet of paper may be stapled in the middle, folded, and delivered (with a Saddle Finisher-K3N/K4N in use).

c. Punching

- A sheet of paper may be punched to open 2, 3, or 4 holes and delivered (with a Finisher-K2N or Saddle Finisher-K3N/K4N, and Puncher Unit-E1/F1 in use).



Finisher-K2N:	2/3 holes.
Saddle Finisher-K3N:	2/3 holes.
Saddle Finisher-K4N:	4 holes.

d. Folding

- A sheet of paper may be folded into a Z and delivered (with a Paper Folding Unit-C1 in use).

e. Trimming

- A booklet which is produced by a Saddle Finisher may be fitted for cutting its edge and delivered (with a Trimmer-A1 in use).



The term “trimming” is used to refer to cutting and smoothing the edge of a booklet.

1.7 High-Level Printer Functions to Support Networking Requirements

- The use of a Network Multi-PDL printer kit (option) will enable a higher level of network printing.

2 Specifications

2.1 Copier

2.1.1 Type

Item	Description
Body	Console
Copyboard	Fixed
Light source	Fluorescent lamp
Lens	Lens array (F3.7)
Photosensitive medium	Amorphous silicon drum (108-mm dia.)

T01-201-01

2.1.2 System

Item	Description
Reproduction	Indirect electrostatic
Charging	Corona
Exposure	Twin laser unit
Copy density adjustment	Auto, or manual (9 settings)
Development	Dry, 1-component toner projection Retard (center reference)
Pickup	<ul style="list-style-type: none"> • Paper deck (2 cassettes; right deck, left deck) • Cassette (2 cassettes; cassette 3, caste 4) • Manual feed tray (5.5 mm deep, approx.; about 50 sheets of 80 g/m² paper)
Transfer	Corona; post charging/exposure (ON for Jpn; OFF for non-Jpn)
Separation	Electrostatic, air
Cleaning	Blade
Fixing	Heat roller 200 V: 1150 W (main) + 565 W (sub) 208 V: 1220 W (main) + 600 W (sub) 230 V: 1185 W (main) + 645 W (sub)
Counter	Soft counter
Toner	Magnetic, positive toner (toner cartridge)

T01-201-02

2.1.3 Functions

Item	Description	
Original type	Sheet, book, 3-D object (2 kg max.)	
Maximum original size	A3/279.4 × 431.8 mm (11 × 17)	
Reproduction ratio	Direct 1:1	
	Reduce I 1:0.250	
	Reduce II 1:0.500	
	Reduce III 1:0.611	
	Reduce IV 1:0.707	
	Reduce V 1:0.816	
	Reduce VI 1:0.865	
	Enlarge I 1:1.154	
	Enlarge II 1:1.224	
	Enlarge III 1:1.414	
	Enlarge IV 1:2.000	
	Enlarge V 1:4.000	
	Zoom:	1:0.250 to 4.000 (25% to 400% in 1% increments)
Fine adjustment of Reproduction ratio	Set ratio in user mode when setting 100%	
Wait time	6 min or less (at 20°C room temperature, rated input)	
First copy time	4.1 sec or less: (stream reading, right deck pickup selected manually, Direct, A4/LTR, non-AE, straight delivery, fluorescent lamp pre-activation ON)	
	2.9 sec or less: (book mode, right deck pickup selected manually, 1 original, Direct, A4/LTR, non-AE, straight delivery, fluorescent lamp pre-activation ON)	
Continuous reproduction	1 to 999 pages	
Size of output	Single-sided AB: A3 max., postcard (vertical feed) min. Inch: 279.4 × 431.8 mm (11 × 17) max., STMT (vertical feed) min.	
	Double-sided AB: A3 max., A5 (vertical feed) min. Inch: 279.4 × 431.8 mm (11 × 17) max., STMT (vertical feed) min.	
	Reading speed	450 mm/s
	Printing speed	500 mm/s
Resolution	600 × 600 dpi in reading; 1200 (equivalent) × 600 dpi in copier mode; 2400 (equivalent) × 600 dpi in printer mode	
Gradation	TBIC method, binary	

T01-201-03

Item	Description
Right deck pick up Left deck pick up	<ul style="list-style-type: none"> • Plain paper (64 to 80 g/m²) A4, B5, LTR • Recycled paper (64 to 80 g/m²) A4, B5, LTR • Eco paper (80 g/m²) A4 • Tracing paper A4, B5 • Colored paper (recommended type) A4 • Thick paper (90 to 200 g/m²) A4, B5, LTR • 3-hole paper (horizontal feed; restrictions on orientation) LTR
Cassette 3 pick up Cassette 4 pick up	<ul style="list-style-type: none"> • Plain paper (64 to 80 g/m²) A3, B4, A4, B5, A4R, B5R, A5R, 279.4 × 431.8 mm (11 × 17), LGL, LTR, LTRR, STMTR • Recycled paper (64 to 80 g/m²) A3, B4, A4, B5, A4R, B5R, A5R, 279.4 × 431.8 mm (11 × 17), LGL, LTR, LTRR, STMTR • Eco paper (80 g/m²) A3, A4, A4R • Colored paper (recommended type) B4, A4, A4R • Thick paper (90 to 200 g/m²) A3, B4, A4, B5, A4R, B5R, LTR, LTRR • 3-hole paper (horizontal feed; restrictions on orientation) LTR, LTRR • Index paper (attachment required) A4, LTR

T01-201-04

Item	Description
Manual feed tray	<ul style="list-style-type: none"> • Plain paper (64 to 80 g/m²) A3, B4, A4, B5, A4R, B5R, A5R, 279.4 × 431.8 mm (11 × 17), LGL, LTR, LTRR, STMT (vertical feed) • Recycled paper (64 to 80 g/m²) A3, B4, A4, B5, A4R, B5R, A5R, 279.4 × 431.8 mm (11 × 17), LGL, LTR, LTRR, STMT (vertical feed) • Eco paper (80 g/m²) A3, A4, A4R • Tracing paper (free of curl and adhesion) A3, B4, A4, B5, A4R, B5R • Transparency (recommended type; horizontal feed, mirror image, straight delivery) A4, A4R, LTR, LTRR • Colored paper (recommended type) B4, A4, A4R • Postcard (horizontal feed) 4-piece postcard pad • Label paper (recommended type) B4, A4, A4R, LTR, LTRR • Thick paper (90 to 200 g/m²) A3, B4, A4, B5, A4R, B5R, LTR, LTRR • 3-hole sheet (horizontal feed) LTR, LTRR

T01-201-05

Item	Description
Single-sided mode	<ul style="list-style-type: none"> • Plain paper (64 to 80 g/m²) A3, B4, A4, B5, A5, A4R, B5R, A5R, 279.4 × 431.8 mm (11 × 17), LGL, LTR, LTRR, STMT (vertical feed) • Recycled paper (64 to 80 g/m²) A3, B4, A4, B5, A4R, B5R, A5R, 279.4 × 431.8 mm (11 × 17), LGL, LTR, LTRR, STMT (vertical feed) • Eco paper (80 g/m²) A3, A4, A4R • Tracing paper (free of curl, and adhesion) A3, B4, A4, B5, A4R, B5R • Transparency (recommended type; horizontal feed, mirror image, straight delivery) A4, LTR • Colored paper (recommended type) B4, A4, A4R • Postcard (horizontal feed) 4-piece postcard pad • Lavel paper (recommended type) B4, A4, A4R, LTR, LTRR • Thick paper (90 to 200 g/m²) A3, B4, A4, B5, A4R, B5R, LTR, LTRR • 3-hole paper (horizontal feed) LTR, LTRR • Index paper A4, LTR

T01-201-06

Item	Description
Face-down delivery mode	<ul style="list-style-type: none"> • Plain paper (64 to 80 g/m²) A3, B4, A4, B5, A5, A4R, B5R, A5R, 279.4 × 431.8 mm (11 × 17), LGL, LTR, LTRR, STMTR • Recycled paper (64 to 80 g/m²) A3, B4, A4, B5, A5, A4R, B5R, A5R, 279.4 × 431.8 mm (11 × 17), LGL, LTR, LTRR, STMTR • Eco paper (80 g/m²) A3, A4, A4R • Tracing paper (free of curl and adhesion) A3, B4, A4, B5, A4R, B5R • Colored paper (recommended type) B4, A4, A4R • Postcard (horizontal feed) 4-piece postcard pad • Label paper (recommended type) B4, A4, A4R, LTR, LTRR • Thick paper (90 to 200 g/m²) A3, B4, A4, B5, A4R, B5R, LTR, LTRR • 3-hole paper (horizontal feed) LTR • Index paper (from cassette) A4, LTR
Double-sided Auto mode	<ul style="list-style-type: none"> • Plain paper (64 to 80 g/m²) A3, B4, A4, B5, A4R, B5R, A5R, 279.4 × 431.8 mm (11 × 17), LGL, LTR, LTRR, STMT (vertical feed) • Recycled paper (64 to 80 g/m²) A3, B4, A4, B5, A4R, B5R, A5R, 279.4 × 431.8 mm (11 × 17), LGL, LTR, LTRR, STMT (vertical feed) • Eco paper (80 g/m²) A3, A4, A4R • Colored paper (recommended type) B4, A4, A4R • Thick paper (90 to 200 g/m²) A3, B4, A4, B5, A4R, B5R, LTR, LTRR • 3-hole paper (horizontal feed) LTR, LTRR

T01-201-07

Item	Description
Double-sided mode	<ul style="list-style-type: none"> • Plain paper (64 to 80 g/m²) A3, B4, A4, B5, A4R, B5R, A5R, 279.4 × 431.8 mm (11 × 17), LGL, LTR, LTRR, STMT (vertical feed)
Manual feed tray	<ul style="list-style-type: none"> • Recycled paper (64 to 80 g/m²) A3, B4, A4, B5, A4R, B5R, A5R, 279.4 × 431.8 mm (11 × 17), LGL, LTR, LTRR, STMT (vertical feed) • Eco paper (80 g/m²) A3, A4, A4R • Colored paper (recommended type) B4, A4, A4R • Postcard (horizontal feed) 4-piece postcard pad • Thick paper (90 to 200 g/m²) A3, B4, A4, B5, A4R, B5R, LTR, LTRR • 3-hole paper (horizontal feed) LTR, LTRR

T01-201-08

Item	Description
Tray	
Right/left deck	162 mm deep approx. (about 1500 sheets of 80 g/m ² paper)
Cassette 3, 4	55 mm deep approx. (about 550 sheets of 80 g/m ² paper)
Capacity of Hard Disc	10 GB
Non-mage width	
Leading edge	Direct/R-E: 4.0 + 1.5/-1.0 mm <4.0 ± 1.8 mm/-1.4 mm>*
Trailing edge	Direct/R-E: 2.5 ± 1.5 mm <2.5 ± 1.8 mm>*
Left/right (first side)	Direct/R-E: 2.5 ± 1.5 mm <2.5 ± 2.0 mm>*
Image margin	
Leading edge	Direct/R-E: 4.0 + 1.5/-1.0 mm <4.0 ± 1.5/-1.0 mm>*
Trailing edge	Direct/R-E: (one-sided) 2.5 ± 1.5 mm <2.5 ± 1.5 mm>*
	Direct/R-E: (two-sided) 2.5 ± 2.0 mm <2.5 ± 2.0 mm>*
Left/right (first side)	Direct/R-E: 2.5 + 1.5 mm <2.5 ± 1.5 mm>* (on left, 0.5 mm or more)
Auto clear	Yes (2 min standard; may be changed between 0 and 9 min in 1-min increments)
Auto power off	No
Power save mode	
Low power mode	Yes (15 min standard; may be changed in user mode: 10, 15, 20, 30, 40, 50, 60, 90 min; 2, 3, 4 hr)
Auto sleep	Yes (60 min standard; may be changed in user mode: 10, 15, 20, 30, 40, 50, 60, 90 min; 2, 3, 4 hr)
Power save mode	Yes (-10% standard; may be changed in user mode: -10%, -25%, -50%, 0% no recovery time)
Option	Finisher-K1N Finisher-K2N Saddle Finisher-K3N Saddle Finisher-K4N FL Cassette-P4 Network Multi-PDL Printer Kit-B1 Stapler-G1 Stapler Cartridge-H1 Stapler-H1 Stapler-D2 Paper Folding Unit-C1 Inserter-B1 Side Paper Deck-N1 Index Paper Attachment-A1 Card Reader-D1 Original holder-D1 Cassette heater (for 230V model only; standard with 200V model; none available for 208V model) Trimmer-A1

* The number in parentheses indicates when an ADF is used.

T01-201-09

2.1.4 Others

	Item	Description
Operating environment	Temperature	15 to 30°C
	Humidity	5 to 80%
	Atmospheric pressure	810.6 to 1013.3 hpa (0.8 to 1.0 atm)
Power supply	200 V/12 A (50/60 Hz)	LQP----
	208 V/12 A (60 Hz)	MPB----
	230 V/13 A (50 Hz)	UNN----
		QNF----
		SNF----
		TNE----
		PNK----
		DNL----
Power consumption	Maximum	200 V: 3.0 kw or less
		208 V/230 V: 3.0 kw or less
Noise	In operation	78 dB or less
	In standby	55 dB or less
Ozone		Initial: 0.02 ppm or less (avr), 0.05 ppm or less (max.)
		Later (after 250,000 pages): 0.05 ppm or less (avr), 0.10 ppm or less (max.)
Dimensions		764 (W) × 795 (D) × 1395 (H) mm (approx.)
Weight		280 kg (approx.; including ADF)
Consumables storage	Paper	Keep wrapped to protect against humidity.
	Toner	Avoid direct sunlight, and keep under 40°C, 85%
Environmental consideration		• Drum Heater (82 W) common for all countries
		• Cassette Heater (20 W) 200 V model: standard 208 V model: none available 230 V model: option
		• Fluorescent Lamp Heater (36 W) common for all countries

T01-201-10

Enlargement/reduction	Size	Paper size	Copies/min (1-to-N)		
Direct	A3 (297 × 420 mm)	A3	50		
	A4 (210 × 297 mm)	A4	105		
	B4 (257 × 364 mm)	B4	57		
	B5 (182 × 257 mm)	B5	105		
	A4R (297 × 210 mm)	A4R	72		
	B5R (257 × 182 mm)	B5R	84		
	A5R (210 × 148 mm)	A5R	105		
Reduce	II (50.0%)	A3 → A5R	A5R	105	
	III (61.1%)	A3 → B5R	B5R	84	
	IV (70.7%)	B4 → B5R	B5R	84	
		A3 → A4R	A4R	72	
	V (81.6%)	B4 → A4R	A4R	72	
		B5R → A5R	A5R	105	
	VI (86.5%)	A4 → B5	B5	105	
		A3 → B4	B4	57	
	Enlarge	IV (200.0%)	A5R → A3	A3	50
		III (141.4%)	A4R → A3	A3	50
B5R → B4			B4	57	
II (122.4%)		A4R → B4	B4	57	
		A5 → B5	B5	105	
I (115.4%)		B4 → A3	A3	50	
		B5 → A4	A4	105	

Delivery from copier, auto paper select, density auto adjust, non-sort, deck/cassette

T01-201-11

Enlargement/reduction Size		Paper size	Copies/min (1-to-N)	
Direct	279.4 × 431.8 mm (11 × 17)	279.4 × 431.8 mm (11 × 17)	49	
	LTR	LTR	105	
	LGL	LGL	59	
	LTRR	LTRR	77	
	STMTR	STMTR	105	
Reduce II (50.0%)	279.4 × 431.8 mm (11 × 17) → STMTR	STMTR	105	
	III (64.7%)	279.4 × 431.8 mm (11 × 17) → LTRR	LTRR	77
	IV (73.3%)	279.4 × 431.8 mm (11 × 17) → LGL	LGL	59
	V (78.6%)	LGL → LTRR	LTRR	77
	Enlarge III (200.0%)	STMTR* → 279.4 × 431.8 mm (11 × 17)	279.4 × 431.8 mm (11 × 17)	49
II (129.4%)		LTRR → 279.4 × 431.8 mm (11 × 17)	279.4 × 431.8 mm (11 × 17)	49
I (121.4%)		LGL → 279.4 × 431.8 mm (11 × 17)	279.4 × 431.8 mm (11 × 17)	49

* STMTR may not be used in the ADF.

Delivery from copier, auto paper select, density auto adjust, non-sort, deck/cassette

T01-201-12

The above specifications are subject to change for product improvement.

2.2 Side Paper Deck-N1

Item	Description
Pickup	Separation roller
Paper accommodation	Side tray
Copy paper type	<ul style="list-style-type: none"> • Plain paper (64 to 80 g/m²) A4, B5, LTR • Recycled paper (64 to 80 g/m²) A4, B5, LTR • Eco paper (80 g/m²) A4 • Tracing paper A4, B5 • Colored paper (recommended type) A4 • Thick paper (90 to 200 g/m²) A4, B5, LTR • 3-hole paper (horizontal feed, restrictions on orientation) LTR
Stack height	385 mm (approx.; about 3,500 sheets of 80 g/m ² paper, about 4,000 sheets of 64 g/m ² paper)
Serial number	XCB----(A4) XCE----(LTR)
Paper size switch	by switching size guide plate (multiple settings) and size in service mode (OPTION)
Dimensions	326.2 (W) × 583 (D) × 574.5 (H) mm (approx.)
Weight	46 kg (approx.)
Power supply/	DC from host copier
Operating environment	Same as copier

T01-202-01

The above specifications are subject to change for product improvement.

3 Names of Parts

3.1 External View

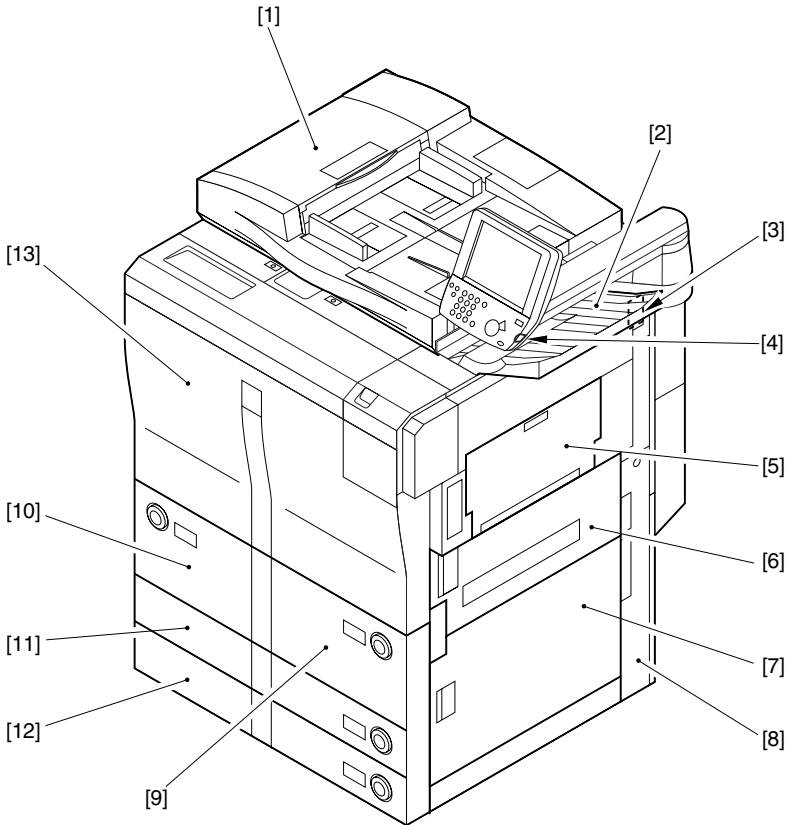

- | | |
|---------------------------------|--|
| [1] ADF | [8] Waste toner box/drum protection sheet case |
| [2] Original delivery tray | [9] Right deck |
| [3] Main power switch | [10] Left deck |
| [4] Control panel power switch | [11] Cassette 3 |
| [5] Manual feed tray | [12] Cassette 4 |
| [6] Vertical path cover (upper) | [13] Front cover |
| [7] Vertical path cover (lower) | |

F01-301-01

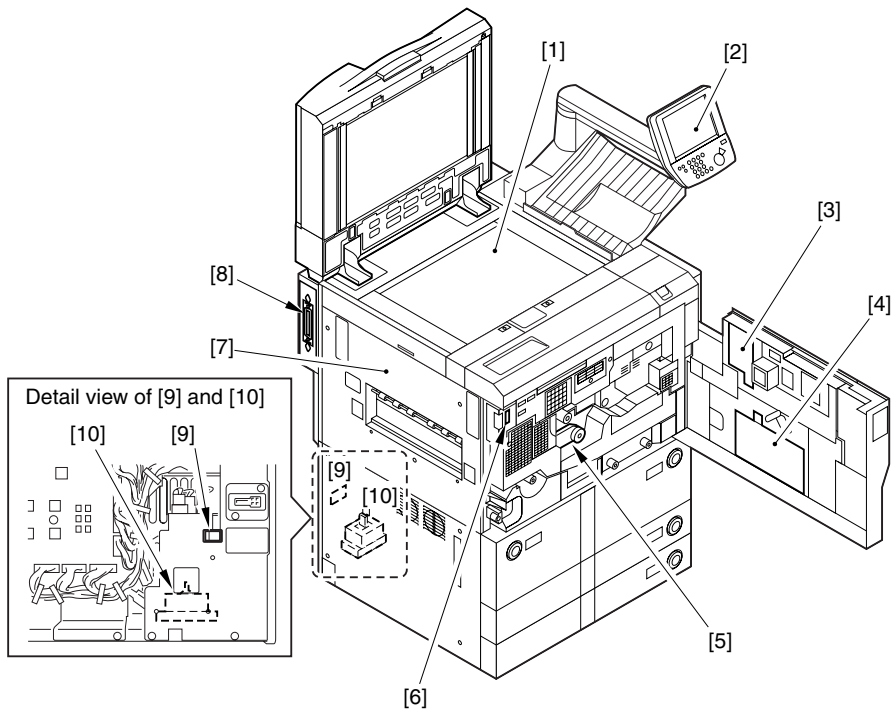

- [1] Copyboard glass
- [2] Control panel
- [3] Grip/drum rotation stopper case
- [4] Service Book Case
- [5] Feeding assembly releasing lever
- [6] Cover switch assembly
- [7] Delivery cover
- [8] Parallel connector
- [9] Heater switch
- [10] Leakage breaker

F01-301-02

Blank page

3.2 Cross Section

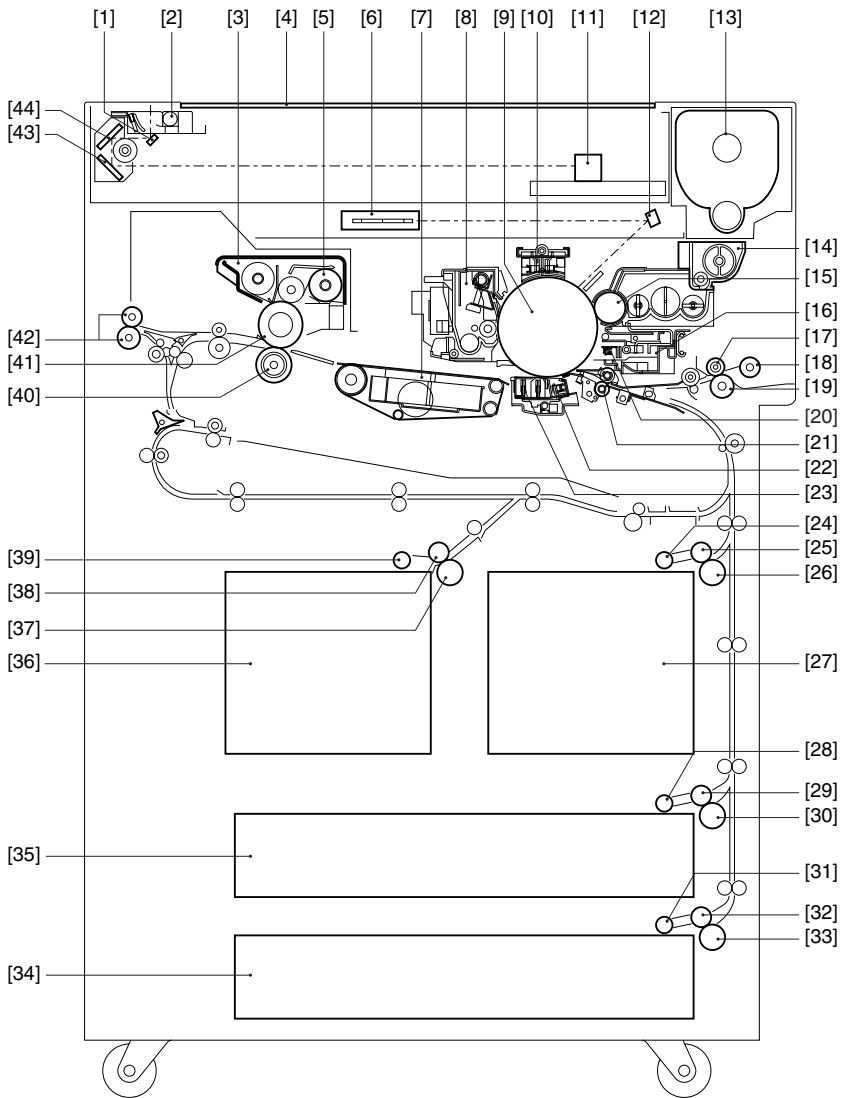

F01-302-01

- | | |
|-------------------------------------|-----------------------------------|
| [1] No.1 mirror | [23] Separate charging assembly |
| [2] Scanning lamp | [24] Right deck pickup roller |
| [3] Fixing assembly | [25] Right deck feeding roller |
| [4] Copyboard glass | [26] Right deck separation roller |
| [5] Fixing web | [27] Right deck |
| [6] Laser unit | [28] Cassette 3 pickup roller |
| [7] Feeding assembly | [29] Cassette 3 feeding roller |
| [8] Drum cleaner assembly | [30] Cassette 3 separation roller |
| [9] Photosensitive drum | [31] Cassette 4 pickup roller |
| [10] Primary charging assembly | [32] Cassette 4 feeding roller |
| [11] CCD unit | [33] Cassette 4 separation roller |
| [12] Bending mirror | [34] Cassette 4 |
| [13] Toner cartridge | [35] Cassette 3 |
| [14] Hopper | [36] Left deck |
| [15] Developing cylinder | [37] Left deck separation roller |
| [16] Pre-transfer charging assembly | [38] Left deck feeding roller |
| [17] Manual feed feeding roller | [39] Left deck pickup roller |
| [18] Manual feed pick roller | [40] Fixing lower roller |
| [19] Manual feed separation roller | [41] Fixing upper roller |
| [20] Pre-transfer exposure LED | [42] External delivery roller |
| [21] Registration roller | [43] No.3 mirror |
| [22] Transfer charging assembly | [44] No.2 mirror |

4 Operation

4.1 Power Switch

The machine is equipped with two power switches: main power switch and control panel power switch. It is turned on when the main power switch is turned on; to end power save mode, low power mode, or sleep mode, turn on the control panel power switch.

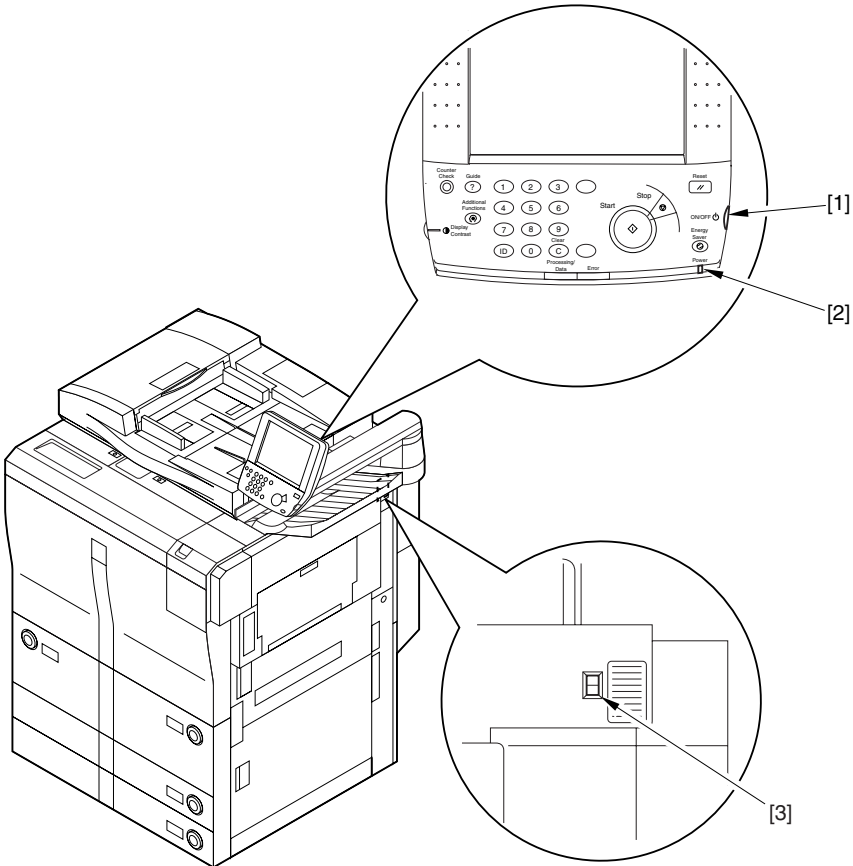

- [1] Control panel power switch
- [2] Main power lamp

- [3] Main power switch

F01-401-01

4.2 Control Panel

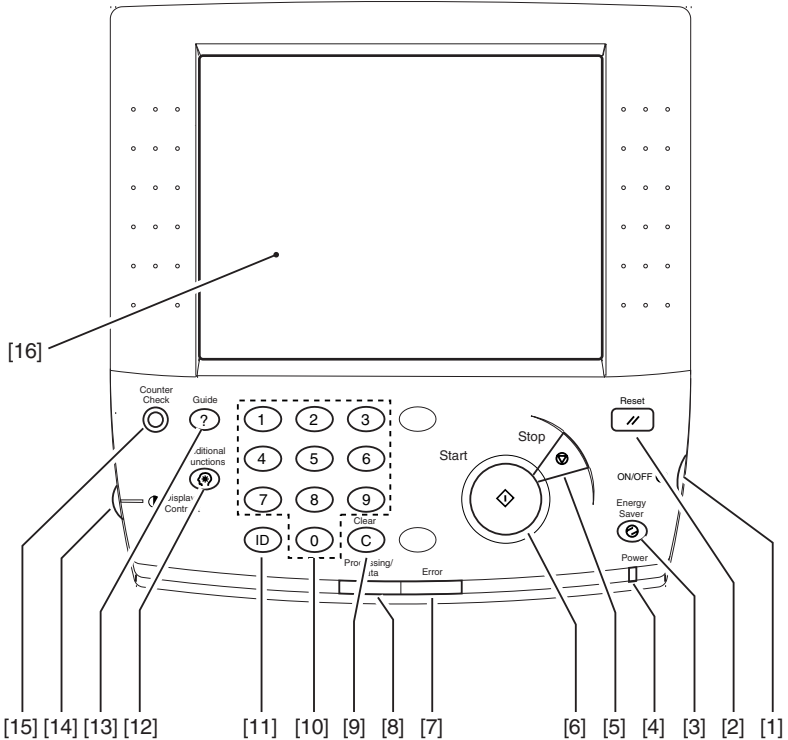

- | | |
|--------------------------------|--------------------------|
| [1] Control panel power switch | [9] Clear key |
| [2] Reset key | [10] Keypad |
| [3] Power Save key | [11] ID key |
| [4] Main power lamp | [12] User Mode key |
| [5] Stop key | [13] Guide key |
| [6] Start key | [14] Image contrast dial |
| [7] Error lamp | [15] Counter Check key* |
| [8] Operation/Memory lamp | [16] Touch panel display |

* Indicates the readings of counters on the touch panel display.

F01-402-01

4.3 Extension Mode Items

Item	Description
Page separation	Use it to copy left and right pages of an open book on separate sheets by a single operation. Note: only used book mode
Cover/Interleaf	Use it to use sheets different from those used for the body for a cover, back cover, interleaf, or chapter leaf. Copies may also be made on sheets for insertion.
Reduced Page Composition	Use it for automatic reduction of 2, 4, or 8 originals, or a double-sided original or a book original for printing on a single sheet of paper (single-/double-sided).
Shift	Use it to shift the entire image of an original to any point (center, corner) for printing.
Book Making	Use it to print single-sided or double-sided originals when producing a booklet.
Transparency Interleaf	Use it to insert a sheet of paper between transparencies used in manual mode. The sheets may also be used to copy the original.
Enlarged Image Composition	Use it for automatic enlargement of a single original after dividing it into 2 or 4 parts for copying on paper of a specified size.
Bind Margin	Use it to create a margin of a specified size on the edge of the copy as binding margin (left, right, top, bottom).
Mixed Sizes	Use it when using originals of different sizes in an ADF for printing according to each size. The originals must, however, be of the same length on one side, e.g., A3 and A4 or B4 and B5.
Continuous Reading	Use it for continuous reading of different sets of originals for printing as a single set.
Frame Erase	Use it to erase the shadow, frame, or image of holes from copies.
Negative/Positive Reversal	Use it to reverse the black and white areas of the original for printing.
Image Repeat	Use it to repeat a single image on copies for as many times as needed (until the entire page is covered) in vertical or horizontal direction.
Mirror Image	Use it to print a mirror image of an image on the original.
Sharpness	Use it to emphasize the contrast of the image for a sharper impression.
Index Paper	Use it when inserting an index sheet/when printing in the index area of an index sheet.
Mode Memory	Use it to store or call a copying mode (9 settings max.).
Call	Use it to call back any of the three most recent copying modes for printing.

T01-403-01

4.4 User Mode



The items associated with the printer are indicated when the printer functions are installed.

Level 1	Level 2	Level 3
Common Settings	Initial Functions	Copy*/Mail Box Set [System Monitor] as the Initial Function: On/Off* Set [Device] as the default screen for [System Monitor]: On*/Off Initial Function*/Selected Function Entry Tone/Error Tone/Job Done Tone (for each, On*/Off) On/Off* (208V model: On*/Off) Copy/Printer/Mail Box/Other (Bypass: On/Off*; each cassette: On*/Off) Consider Paper Type: On/Off* Paper Deck (left/right), Side Paper Deck : Plain*/Recycled/Color/Heavy/Tracing Paper Cassette (3/4): Plain*/Recycled/Color/Heavy/Tracing Paper/Tab Paper -10%*/-25%/-50%/None Low*/High Tray A: copier*/printer*/other* Tray B: copier*/printer*/other* 1 copier (priority)/2 printer/3 other On/Off*
	Auto Clear Setting	
	Audible Tones	
	Inch Entry	
	Drawer Eligibility For APS/ADS	
	Store Paper Type	
	Energy Saver Mode	
	Energy Consumption in Sleep Mode	
	Tray Designation	
	Printing Priority	
	Stack Bypass Standard Settings	

* Factory default.

Level 1	Level 2	Level 3
	Standard Local Print Settings	Paper Select: auto*/pickup position select Copies: 1* to 2000 Finisher: with Finisher-K1N installed, non-sort/Collate/Offset-Collate*/Group/ Offset-Group/Staple (corner (Top Left/Bot- tom Left/Top Right/Bottom Right), Double (left/right)) with Finisher-K2N, Saddle Finisher-K3N/ K4N installed non-sort/Collate/Offset-Collate*/Group/ Offset-Group/Staple (corner (Top Left/Bot- tom Left/Top Right/Bottom Right), Double (left/right))/Hole Punch with Saddle Finisher-K3N/K4N + Paper Folding Unit-C1 installed non-sort/Collate/Offset-Collate*/Group/ Offset-Group/Staple (corner (Top Left/Bot- tom Left/Top Right/Bottom Right), Double (left/right))/Hole Punch/Z-Fold Two-sided Print: On/Off* Erase Document After Printing: On/Off* Merge Documents: On/Off*
	Language Switch	On/Off* Japanese, English, French, German, Italian
	Initialize Common Settings	Yes/No
Copy Settings	Standard key 1 Settings	each mode (No Settings*)
	Standars key 2 Settings	each mode (No Settings*)
	Auto Collate	On*/Off
	Image Orientation Priority	On/Off*
	Job Duration Display	On/Off*
	Auto Orientation	On*/Off
	Photo Mode	On/Off*
	Smart Scan	Initial Setting: On*/Off Change Original Type: On/Off* Recognizable Text: Japanese/European/Rus- sian
	Standard Settings	Store/Initialize
	Initialize Copy Settings	Yes/No

* Factory default.

Level 1	Level 2	Level 3
Timer Settings	Data & Time Settings	Time Zone: GMT – 12:00 to GMT + 12:00 Daylight Saving Time: On/Off*
	Auto Sleep Tme	10, 15, 20, 30, 40, 50 min, 1 hr*, 90 min, 2 to 4 hr (1-hr increments)
	Auto Clear Time	0, 1 to 9 min (1-min increments); 2 min*
	Time Until Unit Quiets Down	0, 1 to 9 min (1-min increments); 1 min*
	Daily Timer Settings	Sun/Mon/Tue/Wed/Thu/Fri/Sat
	Low-power Mode Time	10, 15*, 20, 30, 40, 50 min, 1 hr, 90 min, 2 to 4 hr (1-hr increments)
Adjustment/Cleaning	Zoom Fine Adjustment	X/Y each: -1.0 to +1.0% (in 0.1% increments); 0%*
	Saddle Stitcher Staple Repositioning	Start
	Saddle Stitch Position Adjustment	position: -2.0 to 2.0 mm (0.25-mm increments); 0 mm* (A3, 11 ´ 17/B4/A4R, LTRR)
	Double Staple Space Adjustment	70 to 150 mm (1-mm increments); 120 mm* 2_3/4 to 5_7/8 inch (1/16 inch increments)
	Exposure Recalibration	Light/Dark/9 steps/5 steps*
	Feeder Cleaning	Start
	Wire Cleaning	Start
Mail Box Settings	Box Set/Store	Box No.: 0 to 99
		Store Box Name
		Password
		Doc. Auto Erase: 1, 2, 3, 6, 12 hr; 1, 2, 3, 7, 30 days; none, 3 days*
	Photo Mode	Initialize
	Standard Scan Settings	On/Off* Store/Initialize
Report Settings	User's Data List	Print

* Factory default.

Level 1	Level 2	Level 3
System Settings	System Manager Settings	System Manager ID System Password System Manager E-mail Address Contact Information Comment
	Dept. ID Management	On/Off* (Store Dept. ID/Password, Print Totals, Accept Jobs With Unknown ID)
	Remote UI	On*/Off
	Device Information Settings	Device name Location
	Network Settings	TCP/IP Settings IP Address Setting, DNS Server Setting, PING Command, WINS Configuration, LPD Banner Page NetWare Setting Use NetWare (On/Off*) AppleTalk Setting Use AppleTalk (On/Off*) SMB Setting Server, Printer, Workgroup, Comment, LM Announce (On/Off*)
	Use Spooler	On/Off* Startup Time Settings (0 to 300 sec; 60 sec) Ethernet Driver Settings Auto Detect (On*/Off), Communication Mode, Ethernet Type, MAC Address
	Clear Message Board	Yes/No
	Auto Offline	On/Off*

* Factory default.

CHAPTER 2

NEW FUNCTIONS

1 Basic Construction

1.1 Outline of the Basic Construction

The following shows functions newly added to the machine:

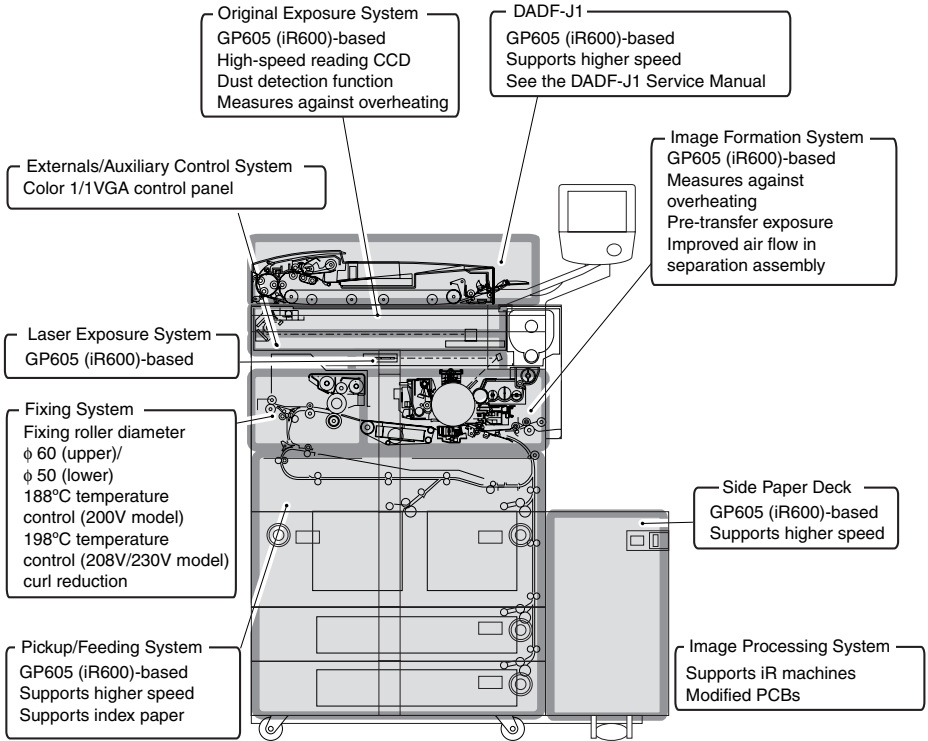

F02-101-01

1.2 Wiring Diagram of the Major PCBs

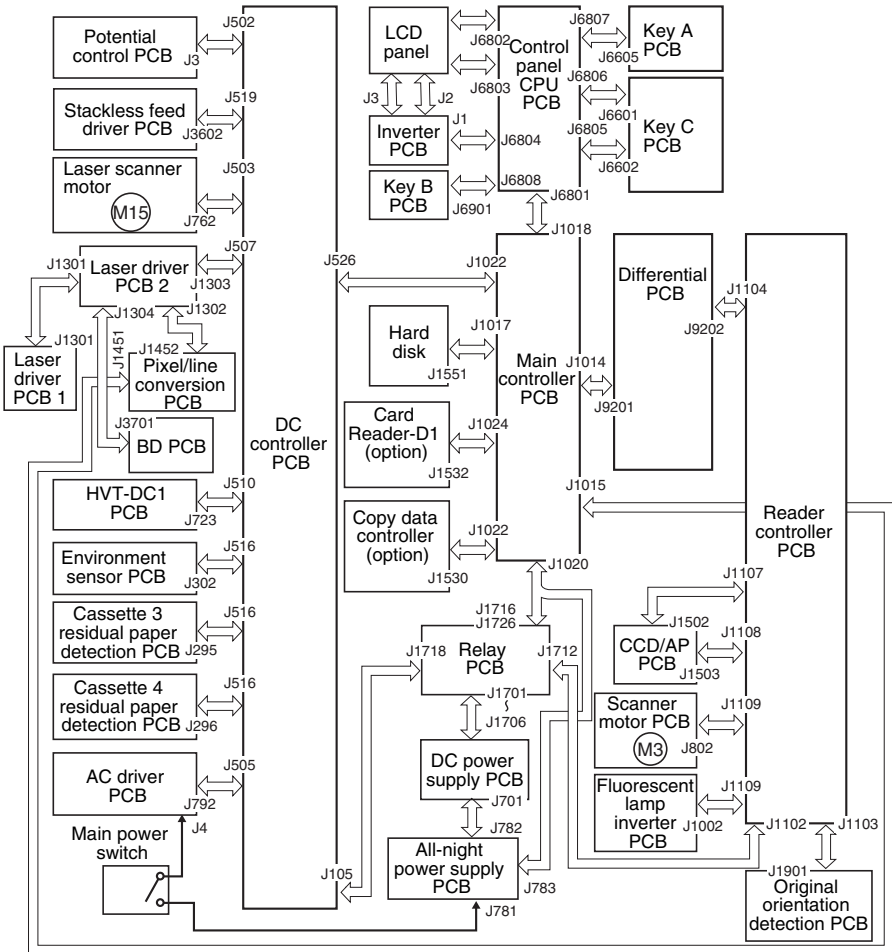

Note: The \longleftrightarrow in the diagram indicates major wiring between PCBs, not the direction of signals.

F02-102-01

2 Original Exposure System

2.1 Outline of the Original Exposure System

The major changes made to the original exposure system are as follows:

- Enlargement/Reproduction
- 4-channel high-speed reading CCD (see discussions of image processing system)
- CCD adjustment (see discussions of image processing system)
- PCB arrangement
- ADF mechanism (new)

For others, see T02-202-01 for a table of differences.

2.2 Changes Made to the Original Exposure System

Unit/location	Change from GP605 (IR600)	Purpose of change	Remarks	Reference
Reading method	Changed the scanning speed at 100% to 450 mm/sec.	To support higher speed of operation.	In the GP605 (IR600), 260 mm/sec.	2.3 Enlargement/Reduction
	Used digital enlargement/reduction (between 25% and 400%). Added a scanner motor fan.	To support higher speed of operation. To prevent overheating of the scanner motor.	In the GP605 (IR600), scanner enlargement/reduction only.	2.3 Enlargement/Reduction
Reader unit	Added a transformer PCB.	To ensure stable inverter power.		2.4 Preventing Overheating of the Scanner Motor 2.6 Stabilizing the Scanning Lamp
Reader controller	Located the reader controller PCB where the image processor PCB was found.			2.5 Arrangement of PCBs
	Added a dust detection mechanism.	To prevent image faults.		2.8 Dust Detection Function in stream reading 2.7 Detecting the State (open/closed) of the ADF
ADF	Added open/closed detection to the ADF.	To prevent wrong detection.		

T02-202-01

2.3 Enlargement/Reduction

Change	iR105	GP605 (iR600)
Scanning speed at 100% copying	450 mm/s	260 mm/s
Enlargement/reduction according to range	By scanner, between 25% and 400% In combination with digital method: in fixed reading, between 25% and 49.9%; in stream reading with ADF in use, between 25% and 84.9%	By scanner only, between 25% and 400%; no digital method used

The machine scans originals faster to support its higher speed of printing. Under specific conditions, it uses a digital method for enlargement/reduction in combination to enable a higher scanning speed, while keeping the speed of the scanner motor to more or less the same as that of the GP605 (iR600).

Normally, copying with the ADF in use is in stream reading; however, fixed reading is used for reduction between 25% and 49.9% and for all ratios in double-sided mode and in book mode.

The digital method of enlargement/reduction is used for the following:

- for fixed reading, if between 25% and 49.9%
- for stream reading, if between 25% and 84.9%

2.4 Preventing Overheating of the Scanner Motor

The machine is provided with a scanner motor cooling fan to prevent overheating of the scanner motor.

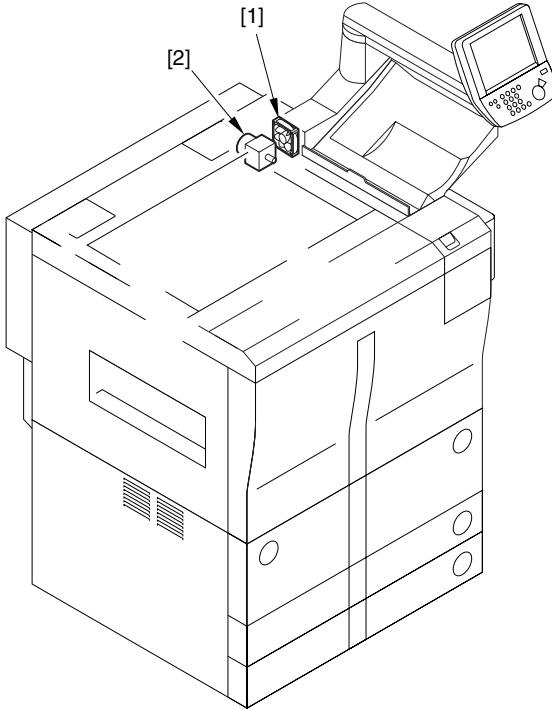

- [1] Scanner motor cooling fan
- [2] Scanner motor

F02-204-01

The scanner motor cooling fan is driven in fixed reading mode under the following conditions to cool the scanner motor:

Operating mode	Fan rotation control
In stream reading mode and standby	Stop
Between 60% and 68.9% reduction and fixed reading	Full speed
Other than above in fixed reading	Half speed

2.5 Arrangement of PCBs

The PCBs of the reader unit are arranged as follows:

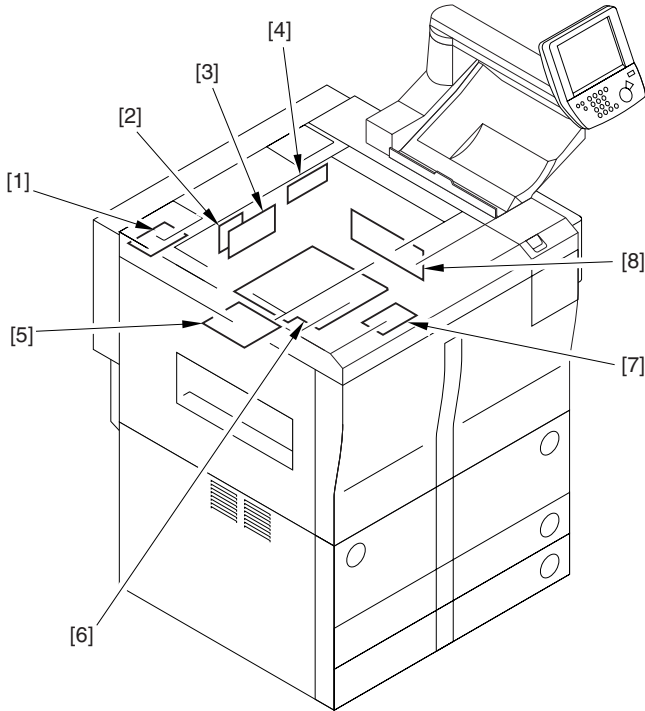

- | | |
|-----------------------------------|--|
| [1] Transformer PCB | [5] Original orientation detection PCB |
| [2] Light adjustment control PCB | [6] Reader controller PCB |
| [3] Fluorescent lamp inverter PCB | [7] Laser scanner motor driver PCB |
| [4] Scanner motor driver PCB | [8] CCD/AP PCB |

The reader controller PCB is located where the image processor PCB was found.

F02-205-01

2.6 Stabilizing the Scanning Lamp

A transformer PCB has been added to increase the voltage supplied to the inverter power supply from 38 to 40 V so that the intensity of the scanning lamp remains stable.

2.7 Detecting the State (open/closed) of the ADF

In addition to the open/closed detection sensor (ON at 30°) used in the GP605 (iR600), the machine's ADF is also equipped with an open/closed detection sensor (ON at 5°), thus enabling the detection of the state (open/closed) of the ADF.

If, for some reason, the state of the ADF sensor cannot be checked, detection will be based solely on the state of the sensor in the machine (as in the case of the GP605 (iR600)).

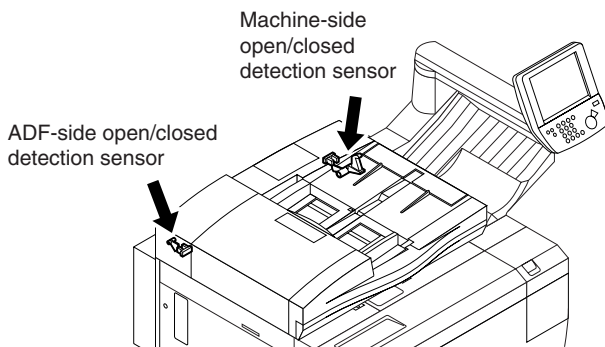

F02-207-01

• When the ADF Is Opened

When the ADF is opened, the ADF-side sensor goes ON as soon as it is opened 5° or higher [1], causing the machine to assume that the ADF has been opened and that the original has been removed; as a result, the size of the original that has been detected automatically will be cleared. Thereafter, when the ADF is opened farther and to 30° or higher [2], the machine-side sensor goes ON, enabling automatic detection of original size.

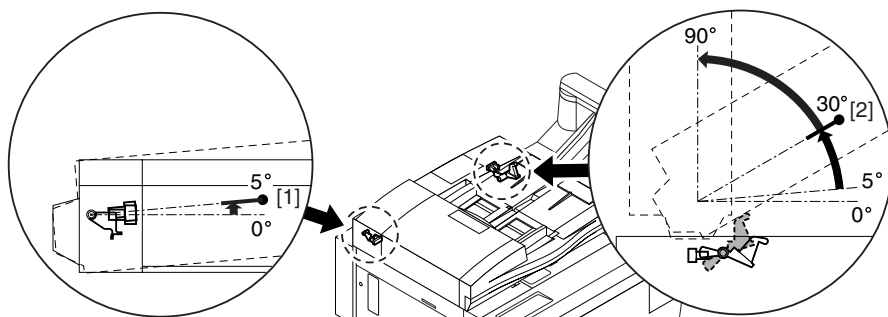

F02-207-02

- When the ADF Is Closed

When the ADF is closed, the machine-side sensor goes ON as soon as it is closed to 30° or lower [3], causing the machine to assume that the ADF is starting to close; 4 sec thereafter, the machine assumes that the ADF is fully closed [4].

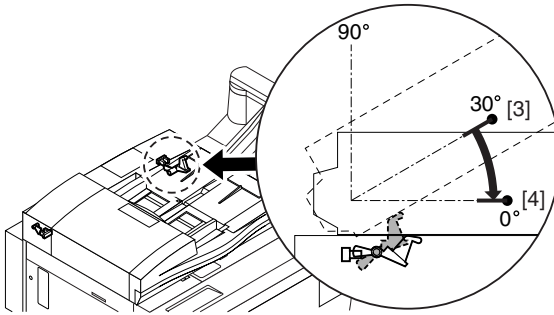

F02-207-03



Memo

Detecting the Size of an Original

The GP605 (iR600) is designed assuming that the ADF is fully closed 3 sec after the machine-side sensor is ON. It compares the states of the original size sensors when the machine-side sensor goes ON and 3 sec thereafter to identify the size of the original on the copyboard glass. If the user, therefore, does not close the ADF within 3 sec after the machine-side sensor goes ON, the GP605 (iR600) can wrongly identify the size as being A3. In the case of the machine, it uses 5 sec for the detection of original size without affecting the first copy time (i.e., by making use of the 2 sec required by the fluorescent lamp to go ON).

2.8 Detecting Dust in Stream Reading

In addition to the common points for stream reading, the machine uses an additional 6 points each for small-size and large-size sheets at intervals of 0.5 mm to avoid areas of dust (in total, 7 points for small-size and 7 points for large-size).

Normally, the machine uses the same point for reading as the GP605 (iR600); if it detects dust, however, it changes the point of reading to prevent dust from appearing in images. The detection of dust is executed at the end of each single job that uses stream reading; the machine moves the ADF belt idly when stream reading is selected and identifies any black line as an area of dust.

When it detects dust, it resets the current point of stream reading, and uses the point of reference on the leftmost edge for dust detection; if dust is detected, it moves the point of stream reading to the right by 1 point (0.5 mm) for detection of dust for a second time. If dust is not detected, the machine uses that point as the point for stream reading. If dust is detected once again, it will use the next point. If dust is detected at all 7 points, the machine will indicate the message “Copyboard Glass Soiled,” which will remain until the ADF is opened and the copyboard glass is cleaned. The machine will not use stream reading but use fixed reading as long as the message remains.

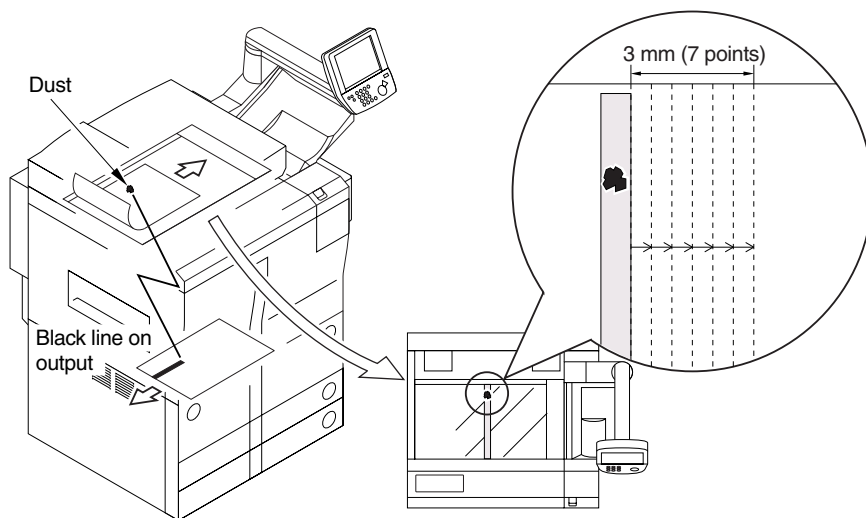

F02-208-01

Advise the user to clean the area where the CCD stops in stream reading if the message has appeared. A label indicating the points for stream reading (for small-size and large-size) is attached to the rear of the copyboard glass.

If a jam has occurred, the machine will not execute dust detection at the end of a job. If the ongoing job is cancelled, it will execute dust detection at the end of operation.

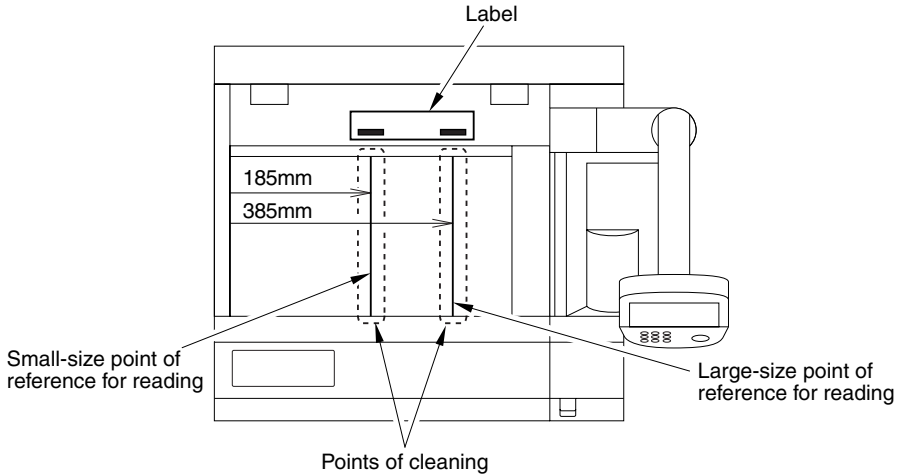

F02-208-02



For the following, the machine can indicate the cleaning message in the absence of dust on the glass:

- The ADF feeding belt is appreciably soiled.
- CCD-ADJ/LUT-ADJ is not executed correctly.

If the message appears, clean the belt (using alcohol) or execute CCD-ADJ/LUT-ADJ.

2.9 Disassembly/Assembly

The mechanical characteristics of the machine are as described herein; disassemble/assemble the machine as instructed and with the following in mind:

1.  Before starting any disassembly/assembly work, turn off the main power switch, and disconnect the power plug.
2. Unless otherwise specifically instructed, assemble the machine by reversing the steps used to disassemble it.
3. Identify the screws by type (length, diameter) and location.
4. To protect against static charges, one of the mounting screws of the rear cover comes with a toothed washer. Be sure not to leave out the washer when assembling the machine.
5. To ensure electrical continuity, the mounting screw for the grounding wire and the varistor comes with a washer. Be sure not to leave out the washer when assembling the machine.
6. As a rule, do not operate the machine with any of its parts removed.
7. When sliding out the duplex feeder unit or the fixing assembly, be sure to turn off the front cover switch or the power switch.

2.9.1 No. 1 Mirror Base Assembly

a. Remove the Scanning Lamp/Scanning Lamp Heater

- 1) Remove the 2 screws [1], and detach the right glass retainer [2].
- 2) Shift the copyboard glass [3] to the right to detach; then, detach the scanning lamp cover [4].

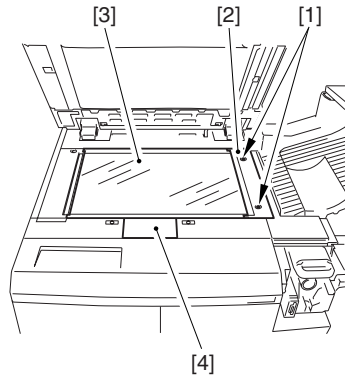

F02-209-01

- 3) Remove the 4 screws [1], and detach the original lamp inside cover [2].

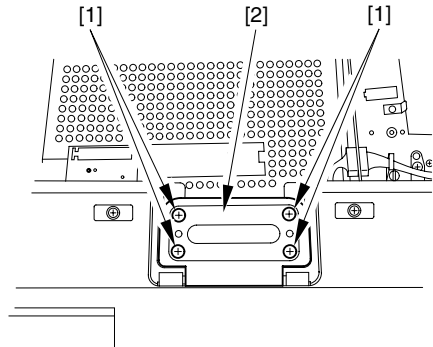

F02-209-02

- 4) Move the No. 1 mirror base [1] to where the scanning lamp mirror inside cover has been removed; then, remove the 2 screws [2], and detach the anti-reflection plate [3].



When moving the mirror base, be sure not to touch the mirror or the lamp or impose force on them to avoid dirt or damage.

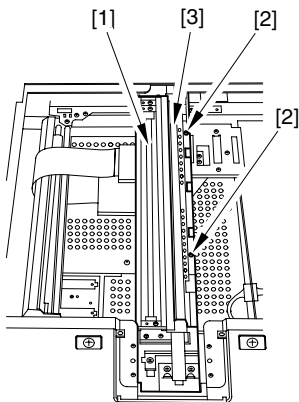

F02-209-03



When mounting the anti-reflection plate, be sure to fit the plate firmly in the cut-in ([2] at front, [3] at rear) of the No. 1 mirror base. Also, be sure that the connector in step 5) is firmly to the anti-reflection plate.

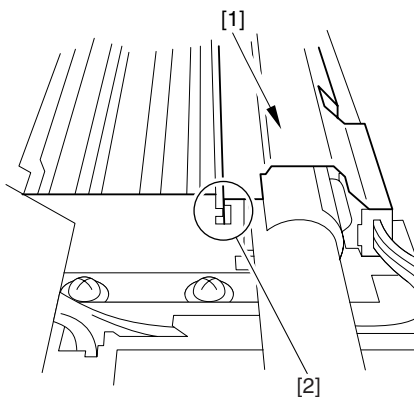

F02-209-04

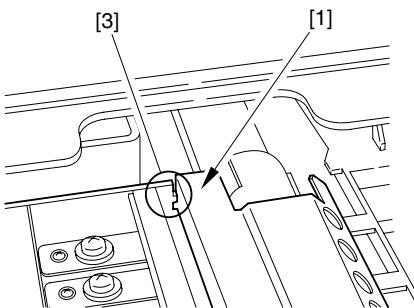

F02-209-05

- 5) Disconnect the connector [1], and remove the 2 screws [2]; then, detach the scanning lamp [4] from the electrode plate (front) [3].

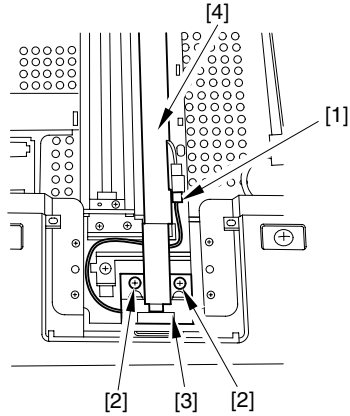

F02-209-06

- 6) Remove the scanning lamp [1] (w/ scanning heater) to the front.

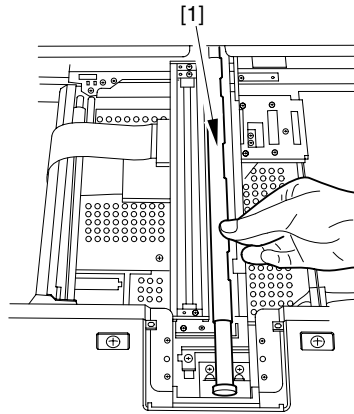

F02-209-07

- 7) Detach the scanning lamp heater [1] from the scanning lamp [2].

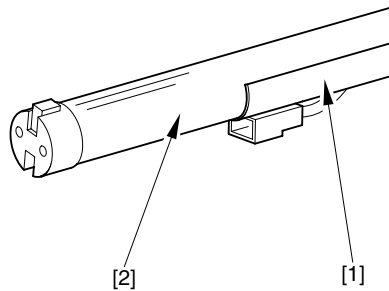

F02-209-08

b. Points to Note When Replacing the Scanning Lamp

- Do not work if the surface of the scanning lamp is hot.
- Do not leave fingerprints on the surface of the scanning lamp.
- If the surface of the scanning lamp is soiled, dry wipe it.
- When mounting the scanning lamp heater [2] to the scanning lamp [1], be sure to fit it with reference to the marking [3]. (The connector [4] of the scanning lamp heater must be to the front of the machine.)
- Also, make sure that the distance A between the top edge of the scanning lamp and the top edge of the light opening [5] is about 6 to 7 mm when viewed from the side.
- When mounting the scanning lamp to the machine, be sure not to touch the light opening [5].

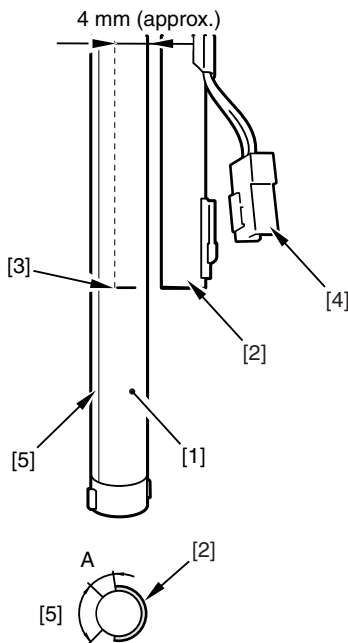

F02-209-09

c. When Replacing the Scanning Lamp

- 1) Check to make sure that the Execute/Memory lamp in the control panel is OFF, and turn off the main power switch.
- 2) Disconnect the power plug from the power outlet.



The machine remains powered as long as the power plug is connected. Be sure to disconnect the power plug from the power outlet without fail.

- 3) Replace the scanning lamp.
- 4) Assemble the machine, and connect the power plug to the power outlet; then, turn on the main power switch.
- 5) Execute the following in service mode in sequence:
 1. COPIER>FUNCTION>CCD>CCD-ADJ
 2. COPIER>FUNCTION>CCD>LUT-ADJ
- 6) Implement the service mode described below to the service sheet which is to be kept in the service log book case.

COPIER>FUNCTION>MISC-P>LBL-PRNT
- 7) Turn off and then on the main power switch.

2.9.2 Scanner Drive Assembly

a. Removing the Scanner Motor

- 1) Remove the ADF.
- 2) Remove the upper right cover. (See 8.4.2.a.)
- 3) Remove the rear cover. (See 8.4.1.e.)
- 4) Remove the upper cover. (2 screws)
- 5) Remove the harness band [1].
- 6) Remove the 2 screws [2], and detach the rear over support plate [3].

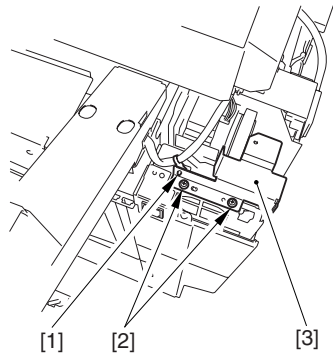

F02-209-10

- 7) Remove the right pocket plate. (3 screws)
- 8) Lift the upper rear cover [1], and remove the 2 screws [2]; then, detach the DF connector unit [3].

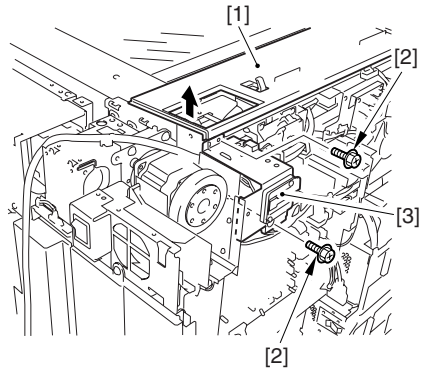

F02-209-11

- 9) Disconnect the connector [1], and free the harness from the 2 edge saddles [2].
- 10) Remove the 3 screws [3], and detach the scanner motor [4].

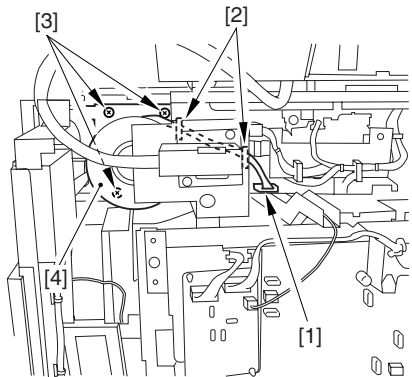

F02-209-12



When mounting it, be sure to set the tension to 10 ± 2 N (1 ± 0.2 kgf) using a spring gauge for correct positioning.

b. Scanner Drive Cable

b-1 Adjusting the Tension of the Scanner Drive Cable

When attaching the scanner cable, be sure to keep a mirror positioning tool (FY9-3040) on hand.

- 1) Remove the ADF.
- 2) Remove the copyboard glass. (see 2.9.1.a.)
- 3) Remove the upper front cover unit. (See 8.4.1.g.)
- 4) Remove the inverter unit. (See 2.9.3.b.)
- 5) Move the No. 1 mirror case where the cable fixing [1] of the base is visible from the opening in the side plate of the machine.



When moving the mirror base, be sure not to touch the mirror or the lamp or impose force to avoid dirt and damage.

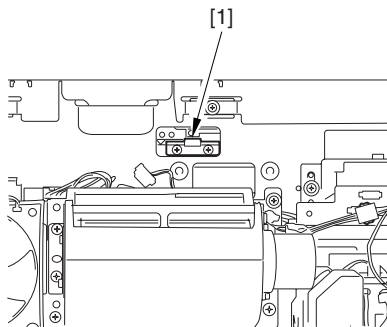

F02-209-13

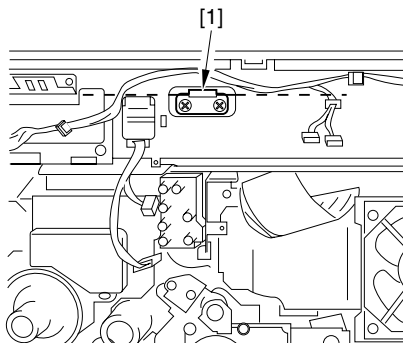

Rear

F02-209-14

6) Fit the scanner cable on the pulley and the hook as indicated.

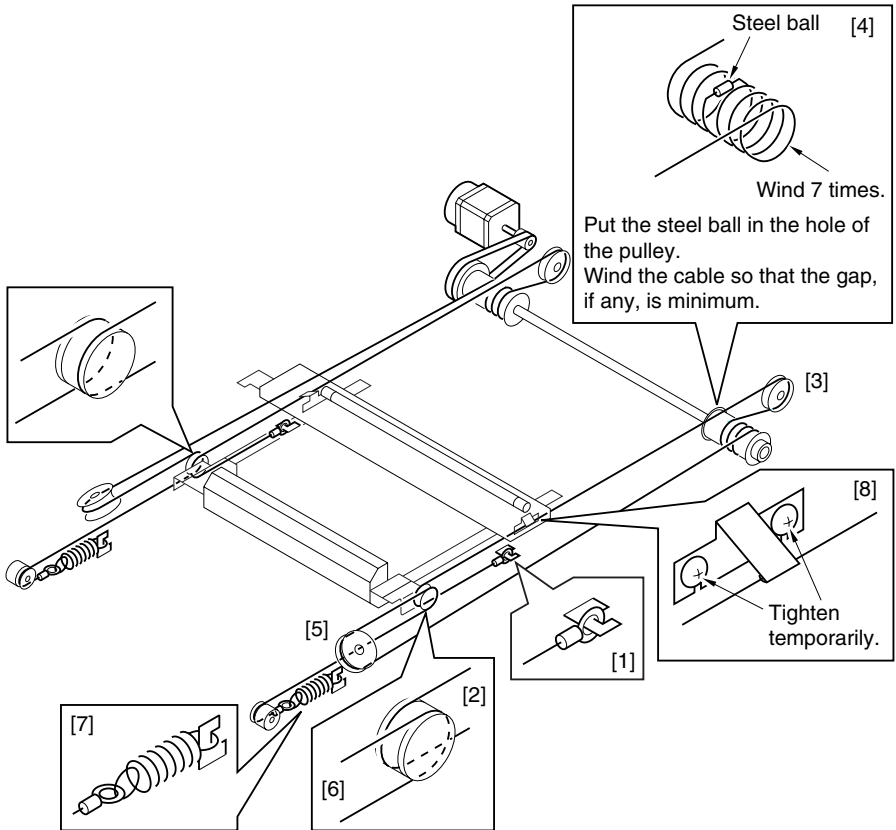

F02-209-15

- 7) Fit the mirror positioning tool [1] between the No. 1 mirror base and the No. 2 mirror base; then, fit the pin [2] attached to the mirror positioning tool.

(front)

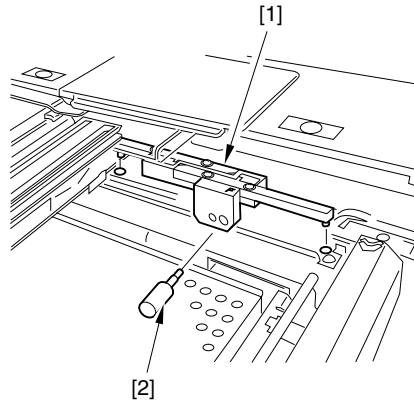

F02-209-16

(rear)

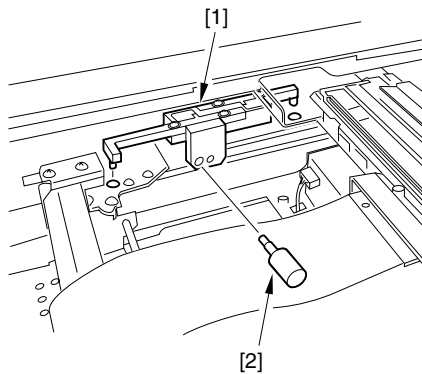

F02-209-17

- 8) Secure the cable fixing [1] that was temporarily fixed in place in step 6) by tightening the 2 screws [2] from the opening in the side plate.

(front)

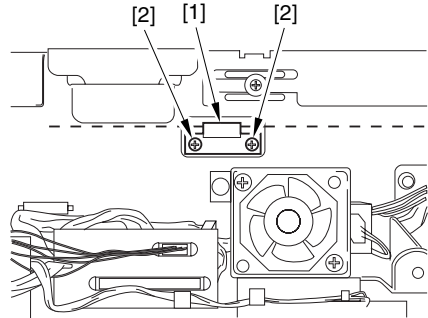

F02-209-18

(rear)

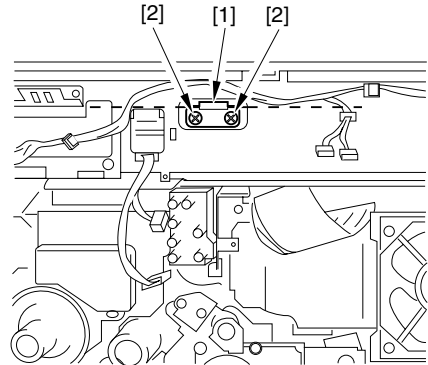

F02-209-19

- 9) Detach the mirror positioning tool.
10) Reverse steps 1) through 4).

b-2 Removing the No. 1 Mirror Case Flexible Cable



Do not disconnect the connector (connected to the No. 1 mirror base) of the flexible cable unless you are replacing the No. 1 mirror base. (Clean the mirror without detaching the cable.)

- 1) Remove the right glass retainer. (2 screws)
- 2) Remove the copyboard.
- 3) Move the No. 1 mirror base [1] to the center.



When moving the mirror base, be sure not to touch the mirror or the lamp or impose force to avoid dirt or damage.

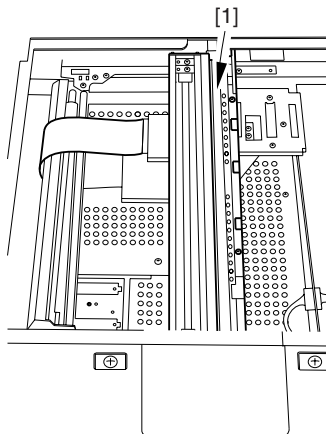

F02-209-20

- 4) Peel off the Warning label [1] from the flexible cable [2].

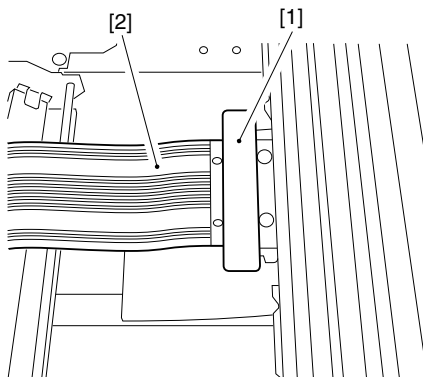

F02-209-21

- 5) Push in the claw [1] inside to free the flexible cable fixing plate [2] of the connector.

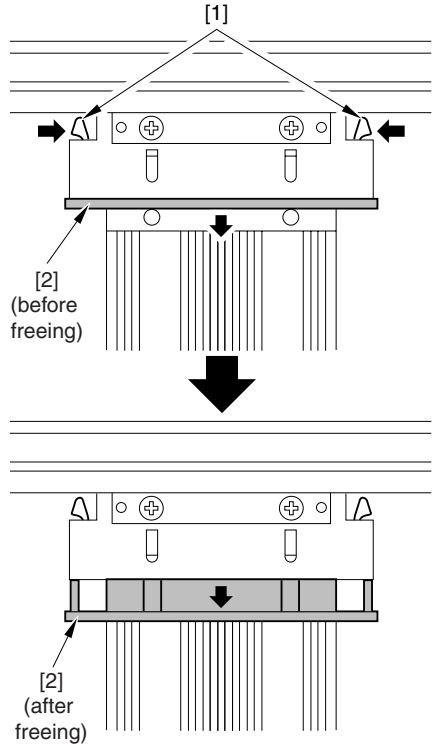

F02-209-22

- 6) Using a small screwdriver [1], push the 2 protrusions [3] used to hook the flexible cable [2]) to disconnect the cable from the connector.



- When mounting it, butt and keep the flexible cable against the rearmost, and push in the fixing plate while holding it level.
- When pushing in the fixing plate, take care not to touch the reflecting plate.

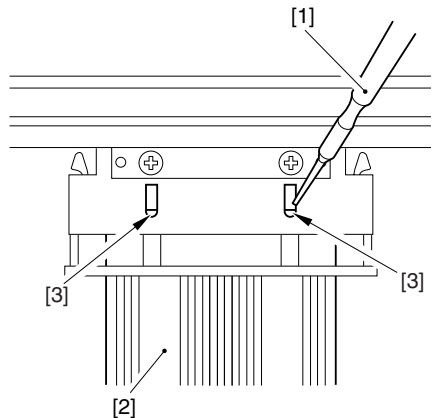

F02-209-23

2.9.3 PCBs

a. Removing the Light Adjustment PCB

- 1) Remove the copyboard glass.
- 2) Remove the screw [1] from the No. 1 mirror base assembly; then, while pushing down the claws [2], detach the light adjustment PCB holder.

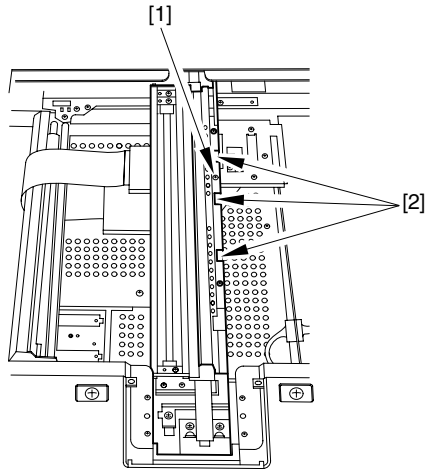

F02-209-24

- 3) Disconnect the connector J165 [1], and remove the screw [2]; then, detach the light adjustment PCB [3].

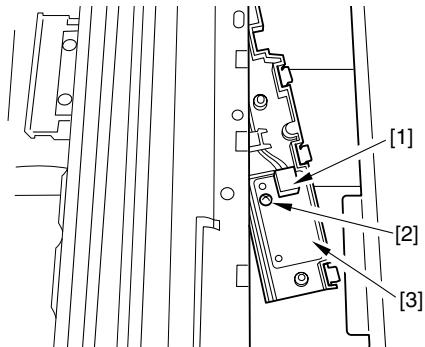

F02-209-25

b. Removing the Inverter PCB

- 1) Remove the rear cover. (See 8.4.1.e.)
- 2) Remove the rear upper cover (2 screws)
- 3) Remove the inverter cooling fan duct. (See 8.4.3.h.)
- 4) Remove the 2 screws [1], and disconnect the 7 connectors [2].

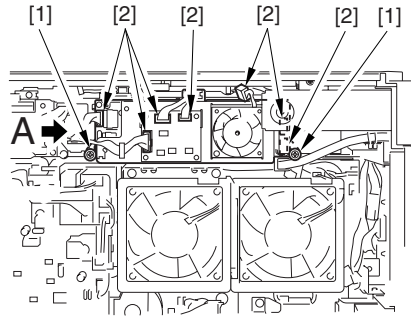

F02-209-26

- 5) Free the left and right hooks [2] (1 pc. each) on the mounting plate of the inverter unit [1], and detach them upward.

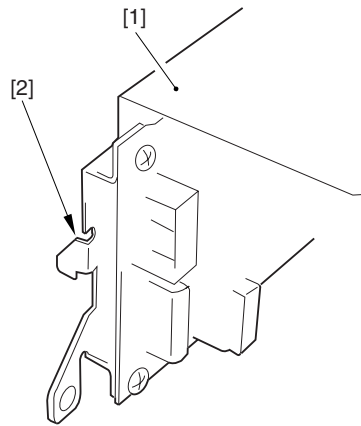

View from A

F02-209-27

- 6) Remove the 6 screws [1], and detach the inverter PCB [2].

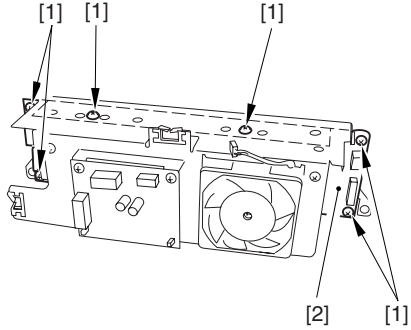

F02-209-28

c. Removing the Transformer Unit

- 1) Remove the rear cover. (See 8.4.1.e.)
- 2) Remove the rear upper cover (2 screws), and remove the upper left cover (3 screws).
- 3) Remove the inverter cooling fan duct. (See 8.4.3.h.)
- 4) Remove the 2 screws [1], and free the reader controller communication cable [2] from the wire saddle [3]; then, detach the transformer unit [4].

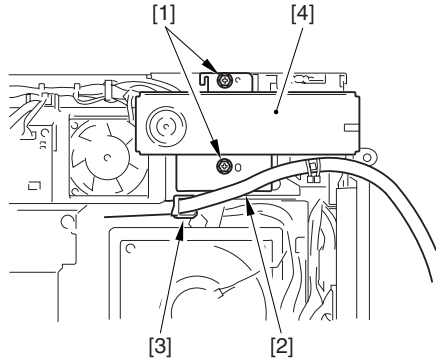

F02-209-29

d. Removing the Transformer PCB

- 1) Remove the rear upper cover. (2 screws)
- 2) Remove the inverter cooling fan duct. (See 8.4.3.h.)
- 3) Disconnect the connectors [1], and remove the 4 screws [2]; then, detach the transformer PCB [3].

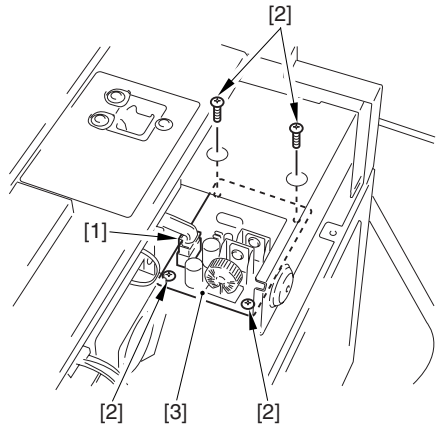

F02-209-30

e. Removing the Reader Controller PCB

- 1) Remove the original size sensor. (See 2.9.4.a.b.)
- 2) Remove the reader controller cover. (See 2.9.4.h.)
- 3) Disconnect all connectors on the Reader Controller PCB.
- 4) Disconnect the DDIS cable [1] and the 2 flexible cables [2]; then, remove the 9 screws [3] and the stepped screw [4], to detach the reader controller PCB [5] in the direction of the arrow.

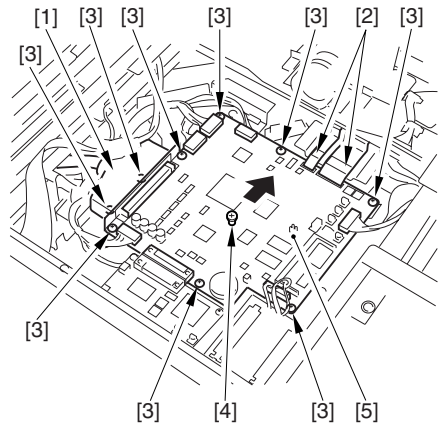

F02-209-31

f. Points to Note When Replacing the reader controller PCB

- 1) Execute the following two items in service mode to print out settings stored under items: COPIER>FUNCTION>MISC-P>LBL-PRNT and COPIER>FUNCTION>MISC-P>USER-PRT.
- 2) Check to make sure that the Execute/Memory lamp in the control panel is OFF, and turn off the main power switch.
- 3) Disconnect the power plug from the power outlet.



The machine remains powered as long as the power plug is connected. Be sure to disconnect the power plug from the wall outlet.

- 4) Replace the reader controller PCB.
- 5) Assemble the machine, and connect the power plug to the power outlet; then, turn on the main power switch.
- 6) Execute the following in service mode: COPIER>FUNCTION>CLEAR>R-CON.
- 7) Turn off and then on the main power switch.
- 8) Execute the following in service mode: COPIER>FUNCTION>CCD>CCD-ADJ.
- 9) Enter the settings printed out in step 1) for the following:
 - service mode
 - COPIER>ADJUST>ADJ-XY (4 items)
 - COPIER>ADJUST>LAMP (1 item)
 - COPIER>ADJUST>CCD (29 items)
 - user mode
- 10) Turn off and then on the main power switch, and execute the following in service mode to generate a service label; keep the service label in the service book case: COPIER>FUNCTION>MISC-P>LBL-PRNT.

g. Removing the Original Orientation Detection PCB

- 1) Remove the reader controller cover. (See 2.9.4.h.)
- 2) Remove the 3 screws [1], and remove the original orientation detection PCB [2] in the direction of the arrow.

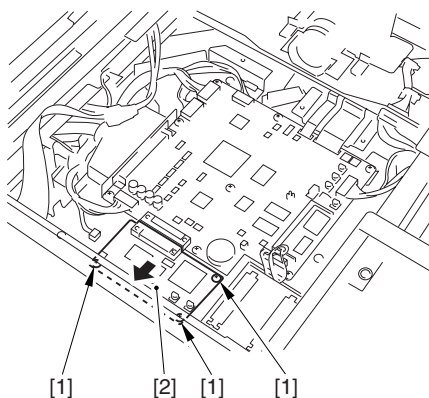

F02-209-32

h. Removing the Reader Controller PCB Unit

- 1) Remove the reader controller cover.
(See 2.9.4.h.)
- 2) Disconnect the 8 connectors of the reader controller PCB, DDIS cable, and 2 flexible cables.
- 3) Remove the 8 screws [1], and detach the reader controller PCB unit [2].

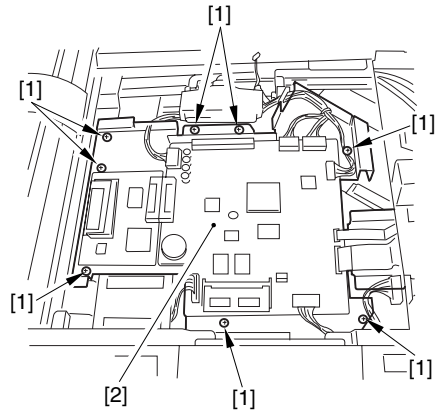

F02-209-33

2.9.4 Others

a. Removing the Original Size Sensor 1/2

- 1) Remove the copyboard glass. (See 2.9.1.a.)
- 2) Move the No. 1 mirror base to the right edge.
- 3) Remove the 2 screws [1], and disconnect the connector [2]; then, detach the original size sensor unit (front) [3].

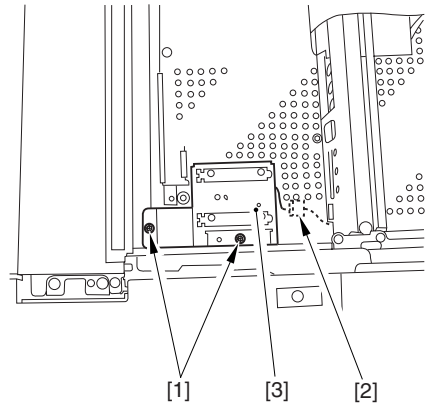

F02-209-34

- 4) Disconnect the connector [1] (1 pc. each), and detach the original size 1/2 [2].

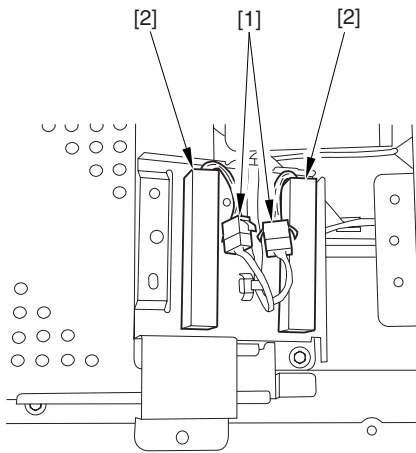

F02-209-35

b. Removing the Original Size Sensor 3/4

- 1) Remove the copyboard glass. (See 2.9.1.a.)
- 2) Move the No. 1 mirror base to the left edge.
- 3) Remove the screw, and disconnect the connector [2]; then, detach the original size sensor unit (rear) [3].

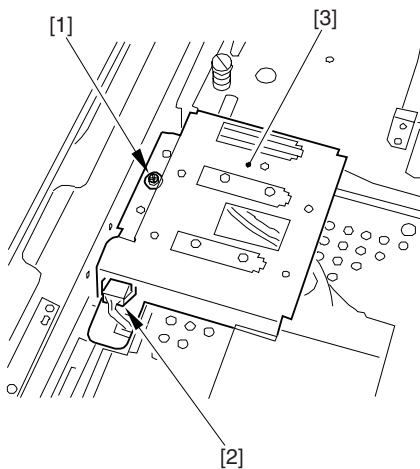

F02-209-36

- 4) Disconnect the connector [1] (1 pc. each), and detach the original size sensor 3/4 [2].

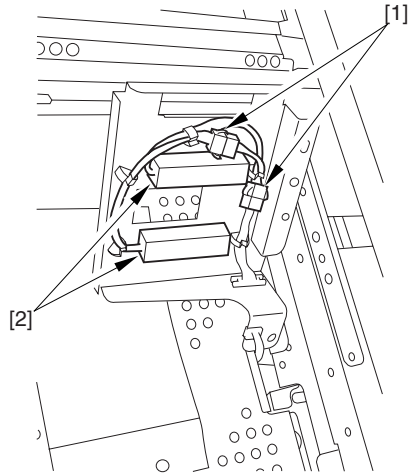

F02-209-37

c. Removing the Scanner Home Position Sensor

- 1) Remove the transformer unit. (See 2.9.3.c.)
- 2) Free the harness from the wire saddle [1]; then, disconnect the connector [2], remove the screw [3], and detach the sensor mounting plate [4].

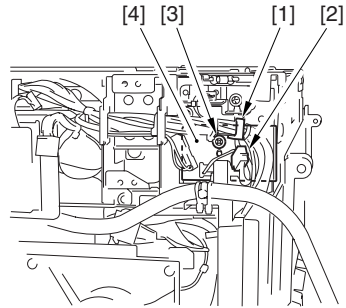

F02-209-38

- 3) Disconnect the connector [1], and remove the screw [2]; then, detach the scanner home position sensor [3].

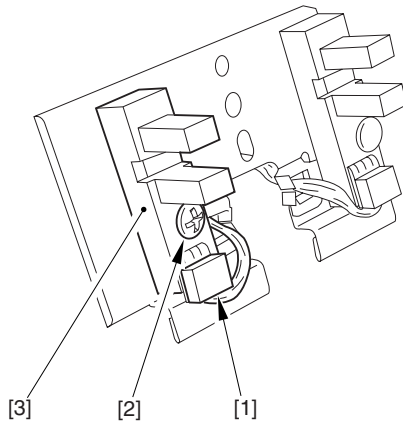

F02-209-39

d. Removing the Copyboard Glass Sensor

- 1) Remove the transformer unit. (See 2.9.3.c.)
- 2) Free the harness from the wire saddle [1], and remove the screw [2]; then, detach the sensor mounting plate [3].

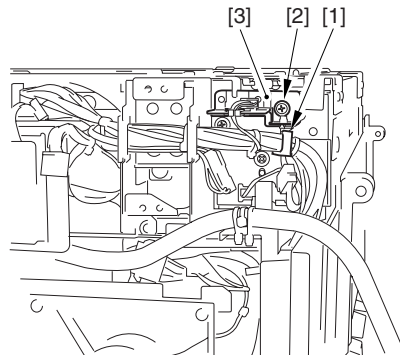

F02-209-40

- 3) Disconnect the connector [1], and detach the copyboard glass sensor [2].

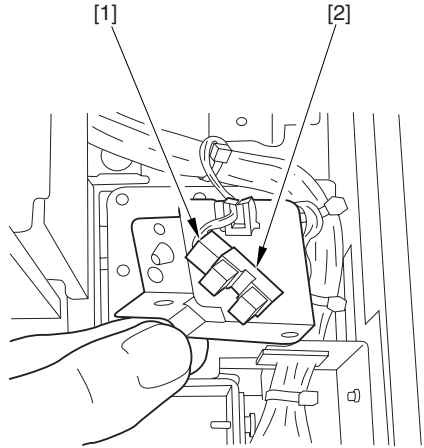

F02-209-41

e. Removing the Image Leading Edge Sensor

- 1) Remove the transformer unit. (See 2.9.3.c.)
- 2) Free the harness from the wire saddle [1]; then, disconnect the connector [2], remove the screw [3], and detach the sensor mounting plate [4].

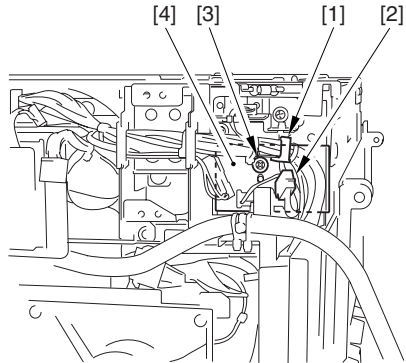

F02-209-42

- 3) Disconnect the connector [1], remove the screw [2], and detach the image leading edge sensor [3].

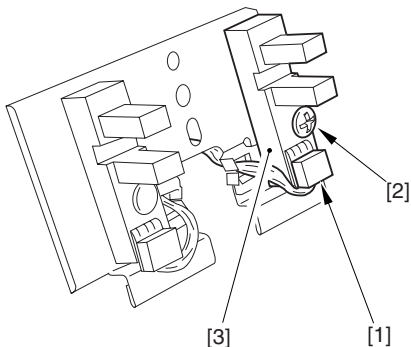

F02-209-43

f. Removing the Standard White Plate

- 1) Remove the copyboard glass. (See 2.9.1.a.)
- 2) Remove the small cover [1] for the standard white plate with a flat-blade screwdriver.

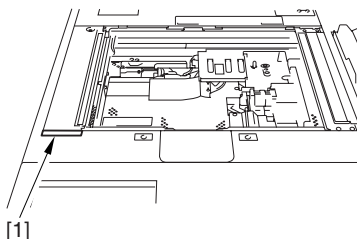

F02-209-44

- 3) Remove the 2 screws [1], and detach the standard white plate cover [2].

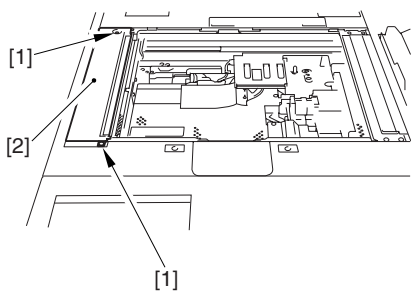

F02-209-45

- 4) Remove the 4 screws [1], and detach the standard white plate [2].

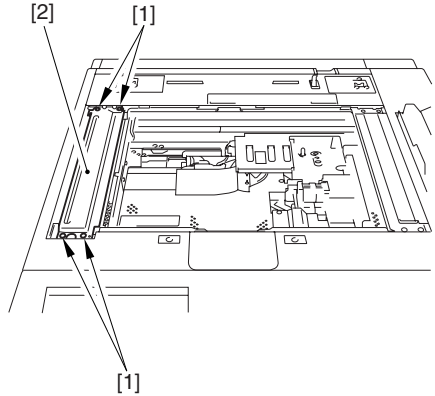

F02-209-46

g. When Replacing the Standard White Plate

- 1) Check to be sure that the Execute/Memory lamp in the control panel is OFF, and turn off the main power switch.
- 2) Disconnect the power plug from the power outlet.



The machine remains powered as long as its power plug is connected. Be sure to disconnect the power plug from the power outlet.

- 3) Replace the standard white plate.
- 4) Assemble the machine, and connect the power plug; then, turn on the main power switch.
- 5) Execute the following in service mode in sequence:
 1. COPIER>FUNCTION>CCD>CCD-ADJ
 2. COPIER>FUNCTION>CCD>LUT-ADJ
- 6) Implement the service mode described below to the service sheet which is to be kept in the service log book case.
COPIER>FUNCTION>MISC-P>LBL-PRNT
- 7) Turn off and then on the main power switch.

h. Removing the Reader Controller Cover

- 1) Remove the original size sensor unit (rear). (See 2.9.4.b.)
- 2) Remove the 2 screws [1], and detach the flexible cable [2] together with the cover sheet [3].
- 3) Disconnect the flexible cable [2] from the connector [4].

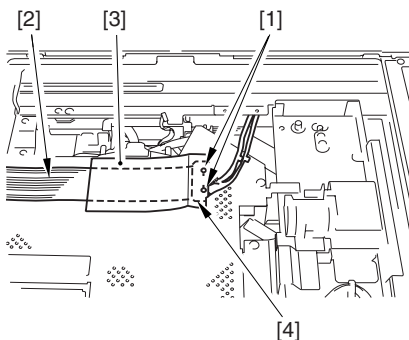

F02-209-47

- 4) Remove the 6 screws [1], and detach the reader controller cover [2].

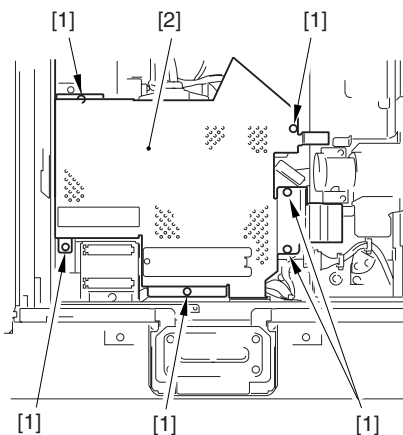

F02-209-48

3 Image Processing System

3.1 Outline of the Image Processing System

The image processing system has the following major functions:

- CCD (image sensor)
 - number of lines: 1; number of pixels: 7500; pixel size: $7 \times 7 \mu\text{m}$
- Shading Correction
 - shading adjustment: executed in service mode
 - shading correction: executed for each copy
- Auto Density Adjustment (AE)
 - executed for each single line in main scanning direction

The following is the functional construction of the image processing system:

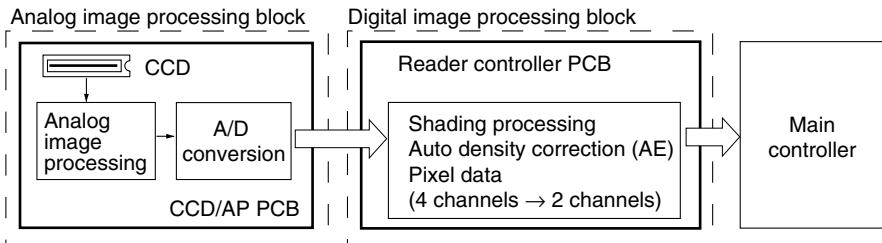

F02-301-01

Each PCB of the image processing system has the following functions:

- [1] CCD/AP PCB
 - CCD drive, analog image processing, A/D conversion
- [2] Reader Controller PCB
 - shading correction, auto density adjustment (AE), image data conversion (4 channels → 2 channels)

3.2 Changes Made to the Image Processing System

Unit/location	Changes from GP605 (iR600)	Purpose of change	Remarks	Reference
Image processing block	Modified the composition for the image processing PCB.	To support iR machines; composition of PCB, IP PCB, MFC PCB.	In the GP605 (iR600), mainly the CCD circuit.	3.1 Outline of the Image Processing System
Main controller	Made to support iR machines.			Chapter 3 Main Controller
HDD	Changed the HDD capacity to 10 GB.	To enhance image processing performance.	In the GP605 (iR600), 2 GB.	
Binary processing	Used the TBIC method as the error diffusion method for text, text/photo, print photo modes.	To enhance image processing performance.	In the GP605 (iR600), the R-ED method.	Chapter 3 Main Controller
	Made to use 141 lines for the dither screen method for print photo mode.	To enhance the resolution of print photos.	For the GP605 (iR600), 106 lines.	Chapter 3 Main Controller
Reader controller	Made to detect the orientation of only the 1st original.	To review the specifications.	In the GP605 (iR600), the orientation of all originals.	3.7 Detecting the Orientation of Originals

T02-302-01

3.3 4-Channel High-Speed Reading CCD

To support high-speed reading at 80 ipm, the machine uses a 4-channel high-speed reading CCD. It consists of two CCDs connected to form a single entity (each, half length of a common CCD); the entire CCD is divided in the middle into first half and last half.

Reading starts simultaneously at both left and right sides, thereby cutting the data transfer time required for reading by half and ultimately enabling high-speed reading.

The image data is divided into 4 channels: first-half even-numbered pixels, first-half odd-numbered pixels, last-half even-numbered pixels, and last-half odd-numbered pixels. The following diagram shows how CCD data is transferred:

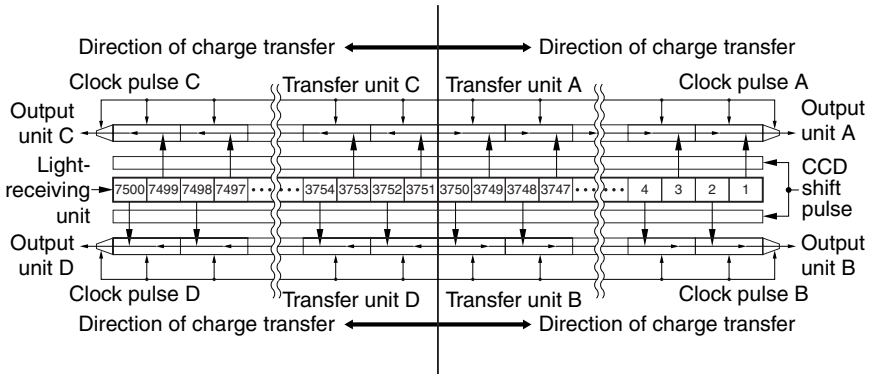

F02-303-01

3.4 CCD Adjustment

As mentioned, the CCD consists of two segments. If the CCD gain characteristics differ between its first half and its last half, the image density read on the left side and the right side of its joint will differ, causing a discrepancy in density in the image.

If the reader controller PCB or the CCD/AP PCB is replaced or when the CCD correction data stored in the S-RAM of the reader controller PCB is lost, CCD correction must be executed in service mode, thereby making the gain around the joint between first half and last half virtually the same. The parameters that occur after adjustment will all be stored in the S-RAM on the reader controller PCB.

The following three methods may be used for adjustment:



A. COPIRE>FUNCTION>CCD>CCD-ADJ (shading auto correction)

Use it to execute shading correction for the CCD (same as the GP605 (iR600)).

B. COPIRE>FUNCTION>CCD>LUT-ADJ (gain simple correction)

Use it to execute CCD gain correction with a blank sheet.

C. COPIRE>FUNCTION>CCD>LUT-ADJ2 (gain full correction)

Use it if CCD simple correction fails. Use it with the 10-Gradation Chart.

Use any of the above methods as needed.



Start with A, and then B; if both fail, execute C. Do not move to B or C without correctly executing A.

3.5 Analog Image Processing

Analog image processing is performed by the CCD/AP PCB, and it mainly consists of the following:

- CCD drive
- CCD output gain correction, offset correction
- CCD output A/D conversion

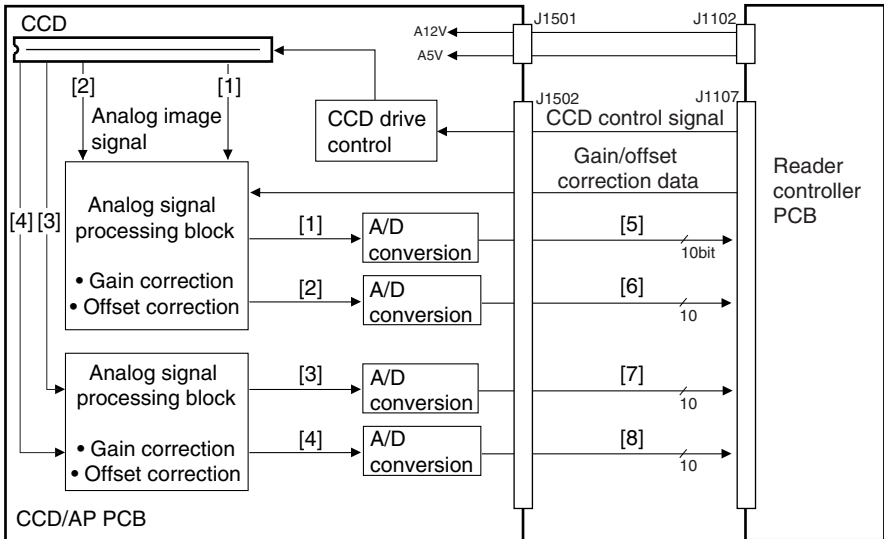

- [1] 1st half even-numbered pixel analog image signal
- [2] 1st half odd-numbered pixel analog image signal
- [3] 2nd half even-numbered pixel analog image signal
- [4] 2nd half odd-numbered pixel analog image signal
- [5] 1st half even-numbered pixel digital image signal
- [6] 1st half odd-numbered pixel digital image signal
- [7] 2nd half even-numbered pixel digital image signal
- [8] 2nd half odd-numbered pixel digital image signal

F02-305-01

3.6 Digital Image Processing

Digital image processing is performed by the reader controller PCB, and it mainly consists of the following:

- shading correction
- auto density correction (AE)
- conversion of 4-channel pixel data to 2-channel pixel data

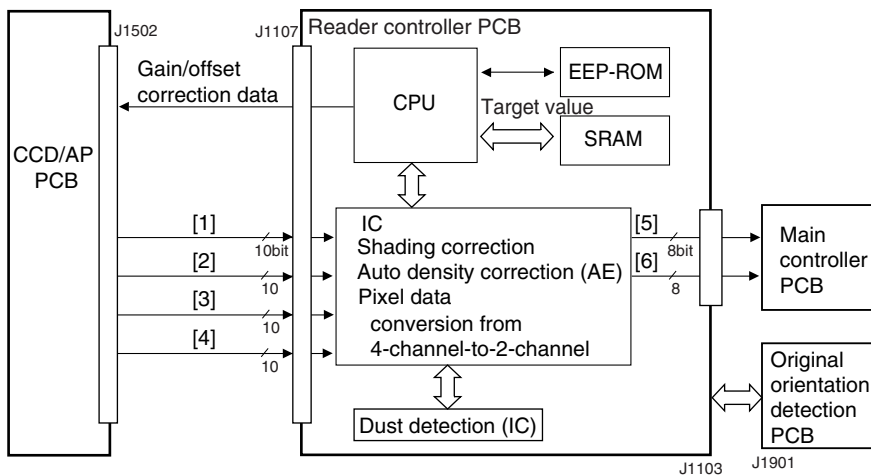

- [1] 1st-half even-numbered pixel digital image signal
- [2] 1st-half odd-numbered pixel digital image signal
- [3] 2nd-half even-numbered pixel digital image signal
- [4] 2nd-half odd-numbered pixel digital image signal
- [5] even-numbered pixel digital image signal
- [6] odd-numbered pixel digital image signal

F02-306-01

3.7 Detecting the Orientation of Originals

The orientation of an original placed in the ADF is detected in relation to the direction of the test area of the original by reading text data. The GP605 (iR600) detects the orientation of each original, making necessary changes for each if necessary. On the other hand, the machine detects the orientation of only the first original, and uses the detected orientation as a reference for changes needed for subsequent pages. The machine uses the result of detection to determine the following:

- binding margin position
- stapling position
- layout orientation for reduced page composition

As needed, the machine rotates the image, thereby reducing waste of paper. The time it saves from not having to detect the orientation of all originals also helps increase its productivity.

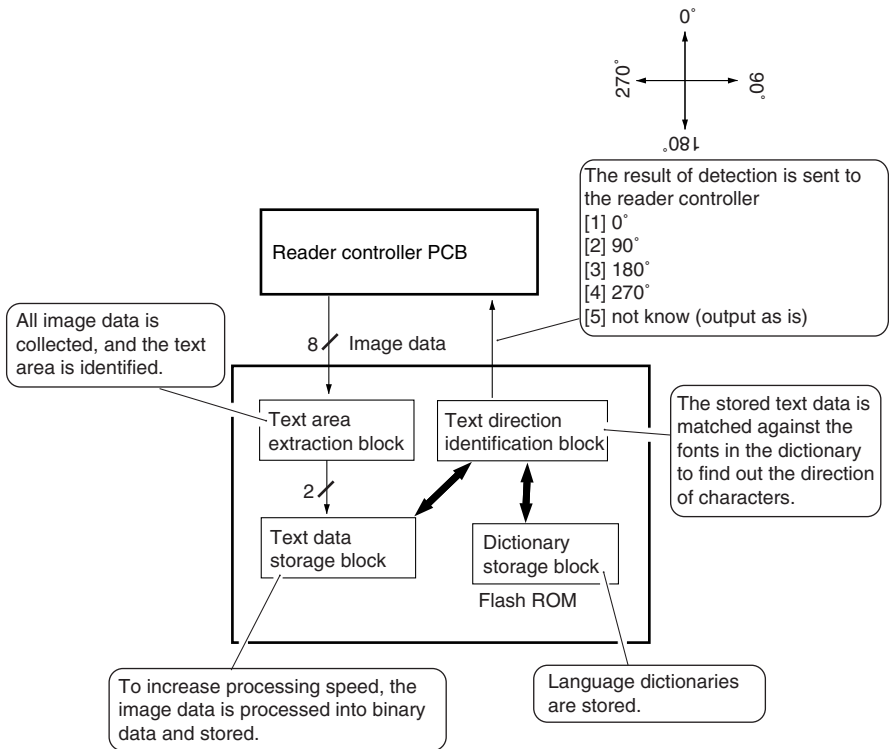

F02-307-01

3.8 Disassembly/Assembly

The mechanical characteristics of the machine are as described herein; assemble/assemble the machine as instructed and with the following in mind:

1.  Before starting any disassembly/assembly work, turn off the main power switch, and disconnect the power plug.
2. Unless otherwise specifically instructed, assemble the machine by reversing the steps used to disassemble it.
3. Identify the screws by type (length, diameter) and location.
4. To protect against static charge, one of the mounting screws of the rear cover comes with a toothed washer. Be sure not to leave out the washer when assembling the machine.
5. To ensure electrical continuity, the mounting screw for the grounding wire and the varistor comes with a washer. Be sure not to leave out the washer when assembling the machine.
6. As a rule, do not operate the machine with any of its parts removed.
7. When sliding out the duplex feeder unit or the fixing assembly, be sure to turn off the front cover switch or the power switch.

3.8.1 CCD Unit

a. Removing the CCD Unit

- 1) Remove the reader controller cover.
(See 2.9.4.h.)
- 2) Free the front/rear claw [2] of the CCD cover [1], and detach the CCD cover.

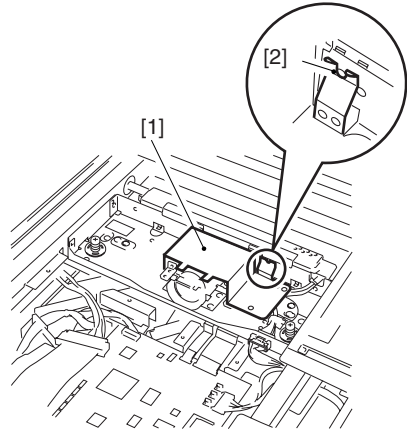

F02-308-01

- 3) Remove the fixing screw [1], spring [2], and spring plate [3], and disconnect the connector (3 locations); then, disconnect the 2 flat cables [5] from the reader controller PCB, and detach the CCD unit [6].

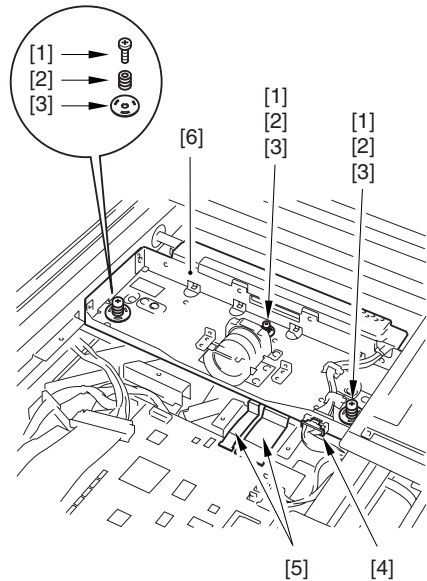

F02-308-02

b. When Replacing the CCD Unit

- 1) Check to make sure that the Execution/Memory lamp in the control panel is OFF, and turn off the main power switch.
- 2) Disconnect the power plug from the power outlet.



The machine remains powered as long as the power plug is connected. Be sure to disconnect the power plug from the power outlet.

- 3) Replace the CCD unit.
- 4) Assemble the machine, and connect the power plug to the power outlet; then, turn on the main power switch.
- 5) Execute the following in service mode in sequence:
 1. COPIER>FUNCTION>CCD>CCD-ADJ
 2. COPIER>FUNCTION>CCD>LUT-ADJ
- 6) All items of the following will be updated; record them on the service label:
COPIER>ADJUST>CCD, COPIER>ADJUST>LAMP>L-DATA.
- 7) Turn off and then on the main power switch.
- 8) Make test copies in book mode and feeder mode to make sure that the images are not displaced; if displaced, execute the following:
Book Mode
A: COPIER>ADJUST>ADJ-XY>ADJ-X
B: COPIER>ADJUST>ADJ-XY>ADJ-Y

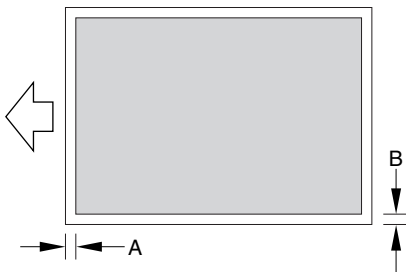

F02-308-03

Feeder Mode

C: COPIER>ADJUST>ADJ-Y-DF

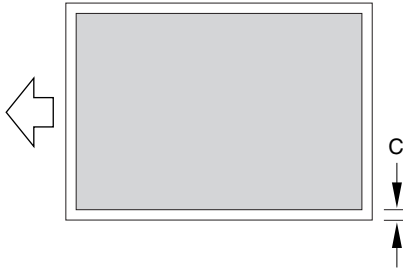

F02-308-04

- 9) Execute the following in service mode to print out a service label, and store away the service label in the service book case.

3.8.2 Hard Disk



as Hard Disks are susceptible to vibration, handle with care.

a. Removing the Hard disk

- 1) Remove the main control box.
- 2) Remove the 5 screws [1], and detach the cover [2].

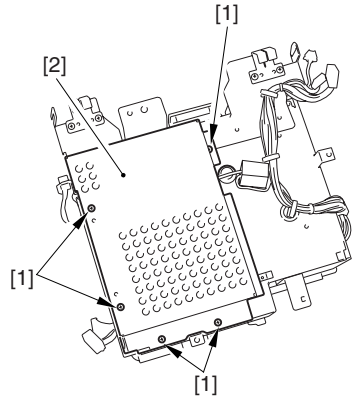

F02-308-05

- 3) Remove the 4 screws [1], and detach the hard disk cover [2].

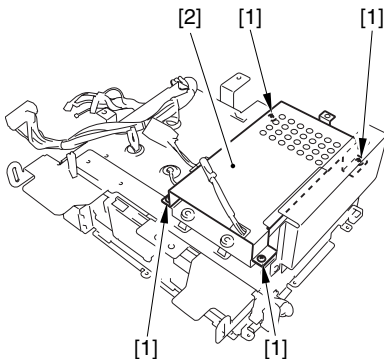

F02-308-06

- 4) Remove the 3 screws [1], and detach the lower cover plate [2].

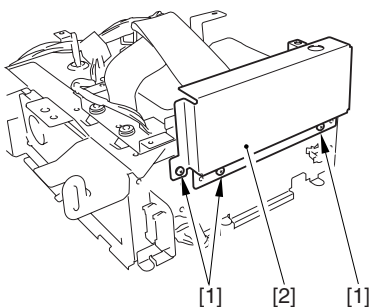

F02-308-07

- 5) Remove the 4 screws [1], disconnect the 2 connectors [2], and remove the mounting screws [4] of the grounding wires [3]; then, detach the hard disks [5] together with the mounting base.

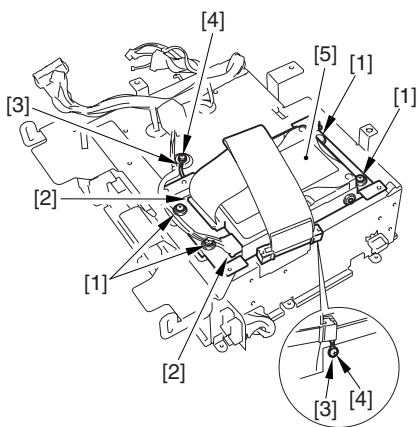

F02-308-08

- 6) Remove the 4 screws [1], and detach the hard disk [2].

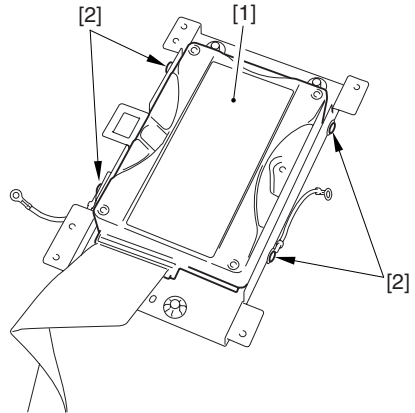

F02-308-09

b. When Replacing the Hard Disk



When replacing the hard disk unit, be sure of the following:

1. Take measures against static charges to protect against static damage.
 2. Do not subject the hard disk unit to impact.
-
- 1) Replace the hard disk unit.
 - 2) Assemble the machine, and connect the power plug to the power outlet.
 - 3) Connect a PC to which the Service Support Tool has been installed.
 - 4) Turn on the PC, and turn on the main power switch while pressing '2' and '8' in the control panel at the same time.
 - 5) Using the Service Support Tool, format the hard disk unit and install the system software.

Blank page

4 Laser Exposure System

4.1 Outline of the Laser Exposure System

The laser exposure system consists of a laser unit (source of laser beams) and a polygon mirror. It scans the photosensitive drum (main scanning direction) to create a latent static image. It is a twin-laser mechanism (laser A, laser B), and its basic construction is as shown in F02-401-01 and T02-401-01.

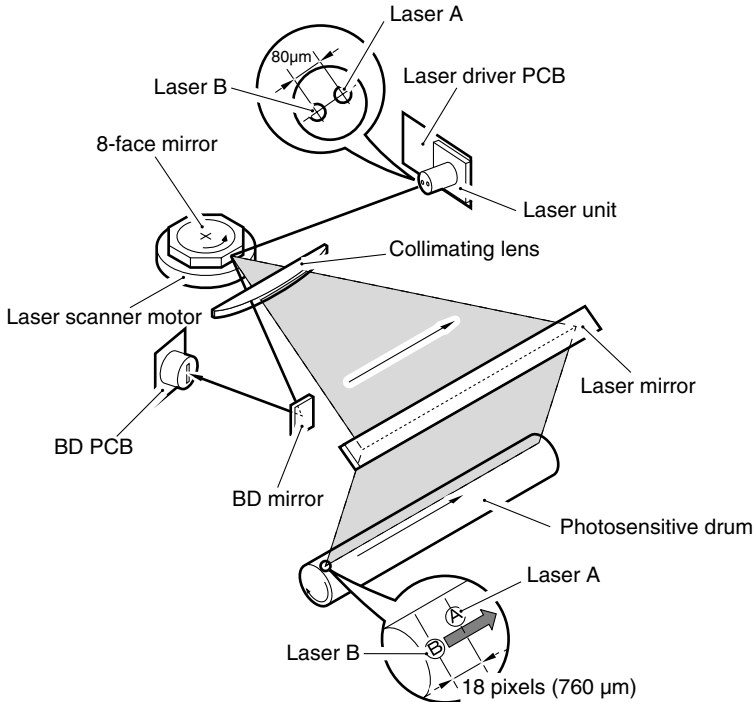

F02-401-01

Component	Description
Laser semi-conductor	Visible laser light (wave length: 675 nm; output: 7 mW), twin-laser exposure
Laser scanner motor (M4)	DC motor, 2-speed control; rotation speed: 44000 rpm
Polygon mirror	8-face
BD mirror/BD PCB	Used to detect laser beams.
Laser driver PCB	Used to control laser activation.
Scanner motor driver PCB	Used to control the rotation of the laser scanner motor.

T02-401-01

4.2 Changes Made to the Laser Exposure System

Unit/location	Changes to GP605 (iR600)	Purpose of change	Remarks	Reference
Laser unit	Increased the laser output to 7 mW.	To support higher process speed.	In the GP605 (iR600), 5 mW.	
Polygon mirror	Increased the rotation speed to about 44000 rpm (full speed). (in standby, about 22000 rpm)	To support higher process speed.	In the GP605 (iR600), about 27000 rpm. (In the GP605 (iR600), about 20000 rpm)	
	Made to use full speed mode in standby.	To support higher process speed.	For the GP605 (iR600), standby rotation.	

T02-402-01

4.3 Disassembly/Assembly

The mechanical characteristics of the machine are as described herein; assemble/assemble the machine as instructed and with the following in mind:

1.  Before starting any disassembly/assembly work, turn off the main power switch, and disconnect the power plug.
2. Unless otherwise specifically instructed, assemble the machine by reversing the steps used to disassemble it.
3. Identify the screws by type (length, diameter) and location.
4. To protect against static charge, one of the mounting screws of the rear cover comes with a toothed washer. Be sure not to leave out the washer when assembling the machine.
5. To ensure electrical continuity, the mounting screw for the grounding wire and the varistor comes with a washer. Be sure not to leave out the washer when assembling the machine.
6. As a rule, do not operate the machine with any of its parts removed.
7. When sliding out the duplex feeder unit or the fixing assembly, be sure to turn off the front cover switch or the power switch.

4.3.1 Laser Unit

a. Removing the Laser Unit

- 1) Remove the CCD unit. (See 3.8.1.a.)
- 2) Remove the reader PCB unit.
- 3) Remove the 6 screws [1], and detach the laser driver PCB cover [2].

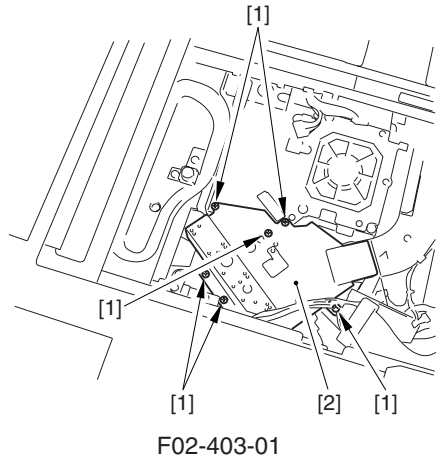

- 4) Disconnect the 4 connectors [1], and remove the video cable [2]; then, remove the 8 screws [3], and detach the laser scanner unit [4].

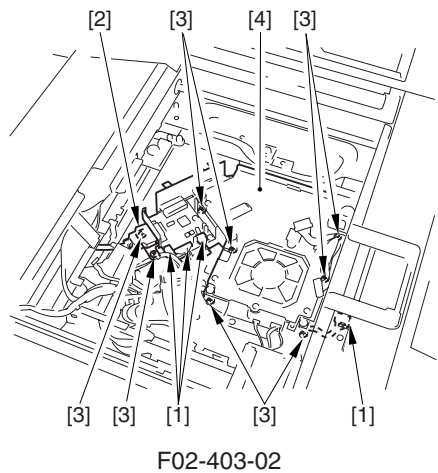

b. Points to Note When Replacing the Laser Unit

- 1) Check to make sure that the Execute/Memory lamp in the control panel is OFF; then, turn off the main power switch.
- 2) Disconnect the power plug from the power outlet.



The machine remains powered as long as the power plug is connected to the power outlet. Be sure to disconnect it.

- 3) Replace the laser unit.
- 4) Record the values (LA-DELAY) indicated on the label attached to the new laser unit.
- 5) Assemble the machine, and connect the power plug to the power outlet; then, turn on the main power switch.
- 6) Enter the values recorded in step 4) using service mode:
COPIER>ADJUST>LASER>LA-DELAY.

4.3.2 BD Unit

a. Removing the BD Unit

- 1) Remove the stream read fan duct. (See 8.4.3.d.)
- 2) Remove the 3 screws [1], and disconnect the 2 connectors [2]; then, remove the laser fan unit [3].
- 3) Slide out the process unit. (See 5.7.1.)

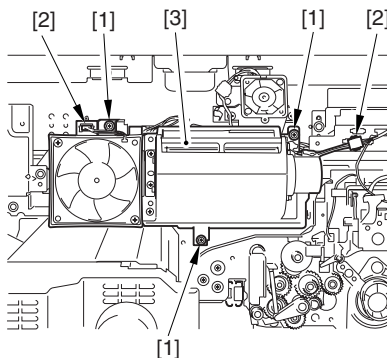

F02-403-03

- 4) Mark the position of the BD unit [1] with a scribe for later reference.
- 5) Remove the screw [2], and slide out the BD unit [1] to the front.

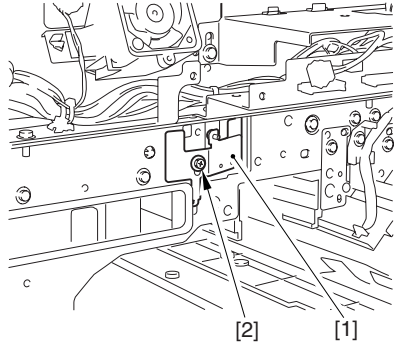

F02-403-04

- 6) Disconnect the connector [1], and take out the BD unit [2].

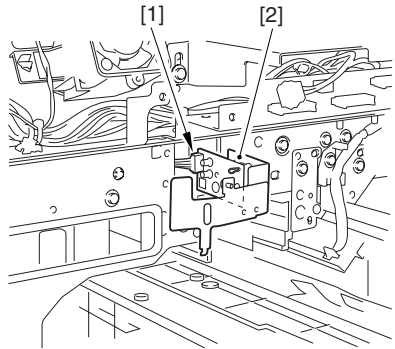

F02-403-05

Blank page

5 Image Formation System

5.1 Outline of the Image Formation System

F02-501-01 shows the major components of the image formation system; F02-501-02, on the other hand, shows the basic sequence of operation. The major changes made to the image formation system are as follows:

- photosensitive drum
- pre-transfer exposure LED (added)
- measures against overheating of developing unit
- measures for enhanced image quality for developing unit
- measures against overheating of cleaning blade

For others, see T02-502-01 for a table of differences.

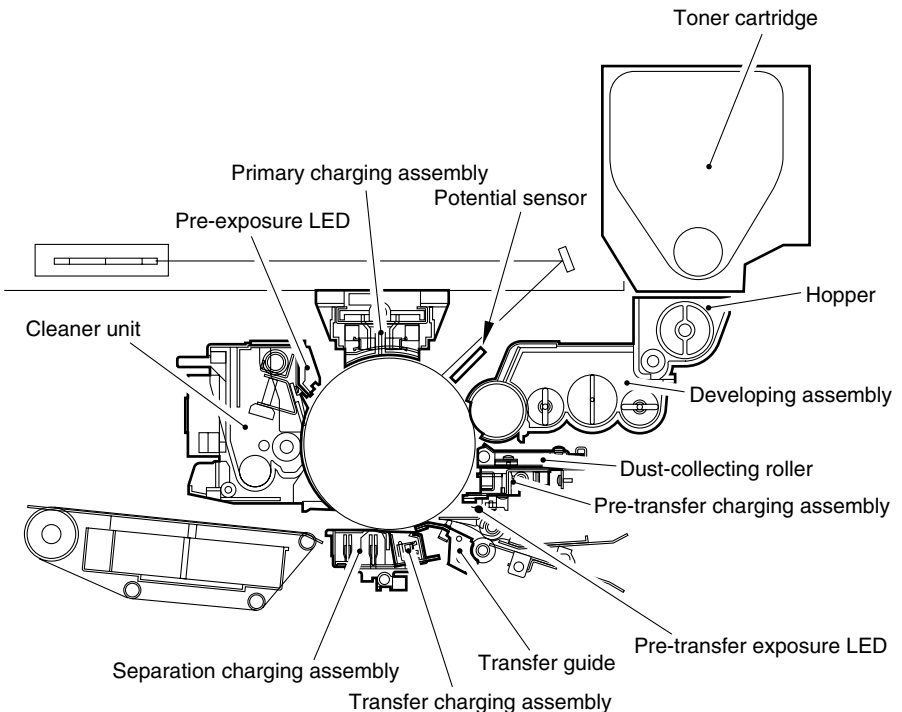

F02-501-01

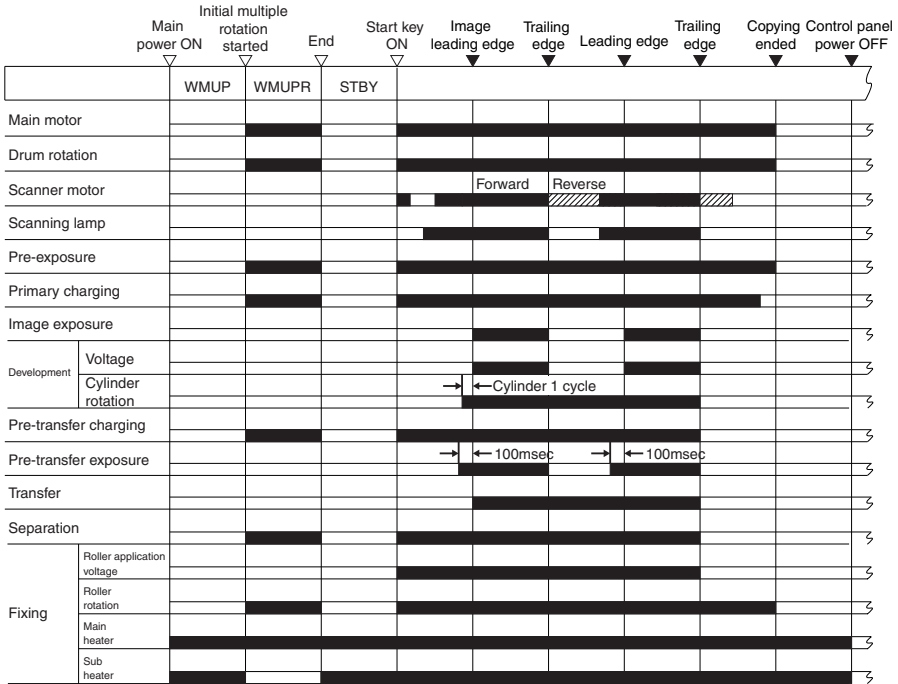

F02-501-02

5.2 Changes Made to the Image Formation System

Unit/location	Changes to GP605 (iR600)	Purpose of change	Remarks	Reference
Photosensitive drum	Increased the charging capacity of the photopositive drum.	To support higher speed of operation.		
Pre-transfer charging assembly	Added a pre-transfer exposure unit.	To improve separation.		5.3 Addition of the Pre-Transfer Exposure Unit
Developing assembly	Added a developing fan for cooling the developing assembly to the front.	To cool the developing assembly.		5.5 Addition of the Developing Fan
	Changing the developing cylinder cover to a heat sink shape.	To enhance cooling of the developing assembly.		5.6 Modifying the Developing Cylinder Cover
	Modifying the developing cylinder	To enhance image quality.		
	Changing the developing bias V/p-p (1.2 kV).	To enhance image quality.		
	Modifying the developing contrast.	To enhance image quality.		
Transfer separation charging assembly	Changing the transfer charging wire height to 9.5 ±0.3 mm.	For enhance transfer performance.	In the GP605 (iR600), 9.6 ±0.4 mm.	
	Changing the No. 2 separation wire height to 17.1 ±0.3 mm. (other charging wires same as GP605 (iR600))	To enhance separation performance.	In the GP605 (iR600), 15.7 ±0.3 mm.	
	Increasing the frequency of the separation AC voltage to 10.0 kV/2 kHz.	To enhance separation performance.	In the GP605 (iR600), 10.5 kV/700 Hz.	
Cleaner	Changed the air flow. (added slit to polygon primary duct)	To cool the cleaning blade.		
	Blade vibration unit added.	To prevent adhesion of toner to the cleaning blade.		See 5.7 "Measures Against Adhesion of Toner to the Cleaning Blade."

T02-502-01

5.3 Addition of the Pre-Transfer Exposure LED

The machine uses a process speed of 500 mm/sec (as opposed to 300 mm/sec in the GP605 (iR600)) to support a copying speed of 105 pages/min (A4, Direct). To make up for the decrease in charging on the photosensitive drum caused by the increase in the process speed, the machine uses a photosensitive drum with a high degree of charging capacity and a pre-exposure lamp with a short wave length (660 nm), thus ensuring a specific degree of charging.

The higher process speed also decreases static charges used for separation; the pre-transfer exposure LED is used to compensate for the decrease:



Memo

Pre-Transfer Exposure

Function: In an initial phase of the transfer process, the charges on the photosensitive drum (background potential) are reduced in advance, thereby weakening the stack bonding between the photosensitive drum and the transfer paper and ultimately encouraging separation.

Timing: The LED is turned on 100 msec before the leading edge of an image reaches a specific point until its trailing edge leaves it; (See F02-502-02)



The pre-transfer exposure LED is enabled/disabled according to paper type in service mode (COPIER>OPTION>BODY>PAPER-TY):

PAPER-TY=1 (paper for 200V model) → ON

PAPER-TY=2 (paper for 208V/230V model) → OFF

5.4 Measures Against Overheating of the Developing Unit

The machine must consider possible overheating of the developing unit caused by the increased process speed. When double-sided copying is performed continuously for a long time, the heat used when fixing on the first sides can heat the developing unit, affect the toner, and cause fogging. To prevent overheating, the following measures have been taken:

- addition of a developing fan
- modification of the developing cylinder cover

5.5 Addition of the Developing Fan

To prevent overheating of the developing assembly [1], a developing fan has been added to the front of the machine. (See 8.2 Fans)

5.6 Modifying the Developing Cylinder Cover

The developing cylinder cover [3] has been turned into a heat sink shape to encourage discharge of heat. A heat pipe [4] is also laid inside of the developing cylinder cover. (See F02-506-01)

The heat pipe has a high degree of heat conductivity, and the air cooled by the developing fan [2] cools the front side of the pipe, ultimately cooling the entire developing cylinder cover to prevent overheating of the developing assembly.

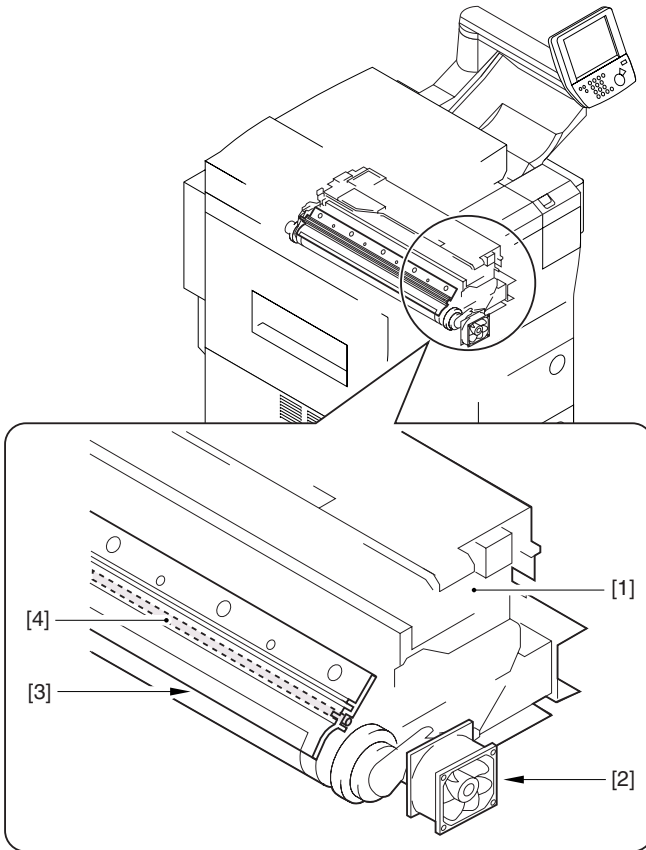

F02-506-01

5.7 Preventing Adhesion of Toner to the Cleaning Blade

The presence of caking toner on the cleaning blade inside the cleaner unit can adversely affect the cleaning of the drum. To prevent caking of toner, the blade of the machine is equipped with 2 blade vibrating units, which vibrate the blade to break and drop cakes of toner, thus preventing drum cleaning faults.

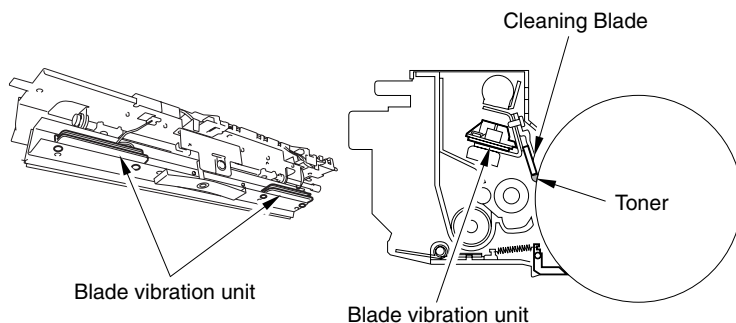

F02-507-01

The blade vibrating units go ON as follows:

- after initial multiple rotation at time of main power-on (5 times or once)
- at stop sequence (once)
- when cleaning wire (pre-transfer, transfer, separation; once)

When vibrating once, it remains ON for 0.6 sec.

When vibrating 5 times, it remains ON for 0.6 sec and OFF for 0.3 sec.



These settings may be changed in service mode to suit the site of installation: COPIER>OPTION>BODY>VBR-M-SW.

The operation of the blade vibrating units may be checked in service mode: COPIER>FUNCTION>PART-CHK>MTR.

5.8 Disassembly/Assembly

The mechanical characteristics of the machine are as described herein; assemble/assemble the machine as instructed and with the following in mind:

1.  Before starting any disassembly/assembly work, turn off the main power switch, and disconnect the power plug.
2. Unless otherwise specifically instructed, assemble the machine by reversing the steps used to disassemble it.
3. Identify the screws by type (length, diameter) and location.
4. To protect against static charge, one of the mounting screws of the rear cover comes with a toothed washer. Be sure not to leave out the washer when assembling the machine.
5. To ensure electrical continuity, the mounting screw for the grounding wire and the varistor comes with a washer. Be sure not to leave out the washer when assembling the machine.
6. As a rule, do not operate the machine with any of its parts removed.
7. When sliding out the duplex feeder unit or the fixing assembly, be sure to turn off the front cover switch or the power switch.

5.8.1 Process Unit

a. Removing the Process Unit

- 1) Remove the developing assembly.
- 2) Remove the process unit cover. (4 screws).
- 3) Slide out the fixing/feeder unit.
- 4) Remove the fixing toner cover; take out the drum protective sheet; and lay it over the fixing/feeder unit.
- 5) Disconnect the connector [1], and release the stopper lever [2]; then, detach the primary charging assembly [3].
- 6) Disconnect the connector [4], and release the stopper lever [5]; then, detach the pre-transfer charging assembly [6].

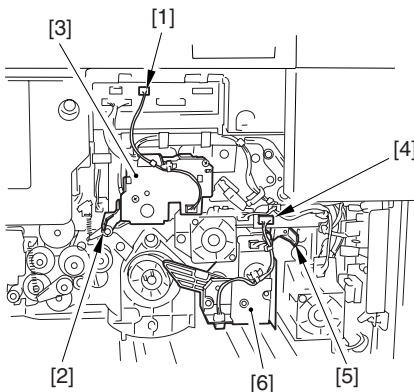

F02-508-01

- 7) While using the drum stop [1] (found inside the compartment behind the front cover) to fix the drum in place, remove the screw [2], and detach the drum fixing block [3].
- 8) Detach the drum stopper [1].
- 9) Remove the 3 screws [4], and disconnect the connector [5]; then, slide out the process unit [6].

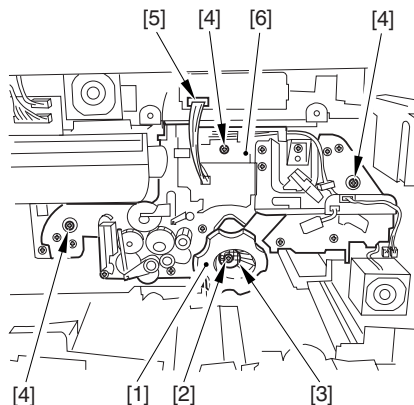

F02-508-02

- 10) Slide fully out the process unit [1], and pull out the grip [2] on the right side.
- 11) Holding the grip [2] on the right and the grip [3] on the left, lift it upward.

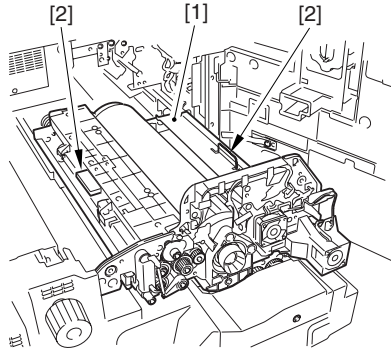

F02-508-03



When placing the removed process unit, turn the kit support plate [1] counterclockwise, and be sure to create a gap from the floor to prevent damage.

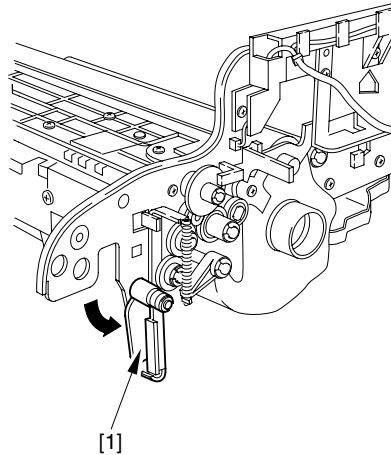

F02-508-04

b. Mounting the Process Unit

Keep the following in mind when mounting the process unit [1] to the slide rail:

- 1) Be sure to match the notch [2] found at the tip of the left slide rail against the front plate [3] of the process unit.
- 2) Be sure to match the bend [4] at the front of the right slide rail against the front plate [3] of the process unit.



Waste toner can drop on the duplex unit when the process unit is removed. After mounting the process unit, be sure to slide out the duplex unit and remove the waste toner.

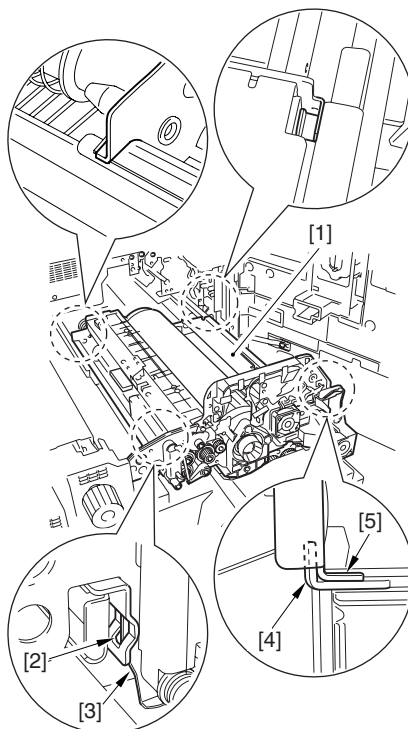

F02-508-05

c. Removing the Photosensitive Drum

Points to Note When Handling the Photosensitive Drum

The machine's photosensitive drum is made of high-sensitivity amorphous silicon, and thus its sensitivity can deteriorate if it or the process unit is not placed properly. When handling the process unit or the photosensitive drum, keep the following in mind:

1. If you have removed the process unit from the machine, protect the photosensitive drum from light by using the photosensitive drum protection sheet or by wrapping 6 or more A3 or larger sheets.
2. Do not place the process unit or the photosensitive drum in an area exposed to direct rays of the sun.
3. Do not place the process unit or the photosensitive drum in an area subject to high temperature/humidity or low temperature/humidity or rapid changes in temperature or humidity.
4. Do not place the process unit or the photosensitive drum in an area subject to dust, ammonium gas, or organic solvent gas.

The foregoing equally holds true for the photosensitive drums of all models.

- 1) Remove the developing fan. (See 8.4.3.m.)
- 2) Slide out the process unit. (See 5.8.1.a.)
- 3) Remove the 3 screws [1], and disconnect the 2 connectors [2]; then, detach the sub plate assembly [3].

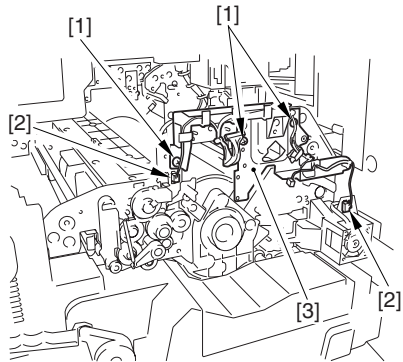

F02-508-06

- 4) Remove the 2 screws [1], and detach the positioner holder [2].

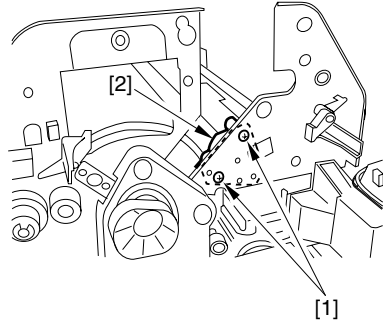

F02-508-07

- 5) Remove the 3 screws [1], and detach the drum fixing plate [2].

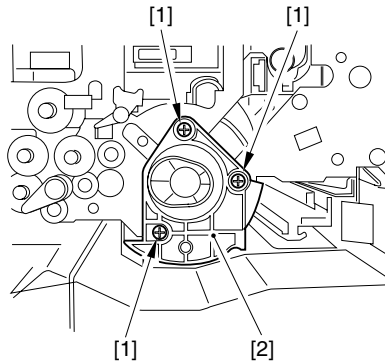

F02-508-08

- 6) Remove the screw [1], and detach the bearing stopper [2]; then, shift the photosensitive drum [3] to the front (in the direction of the arrow) to lift.

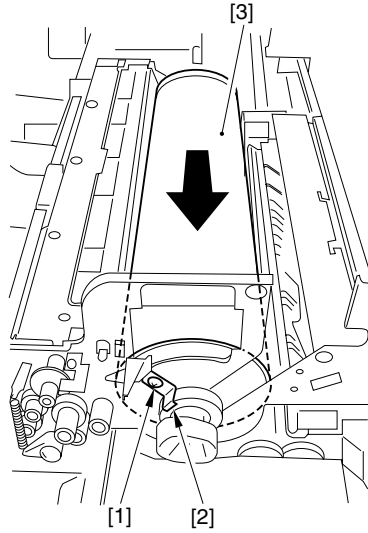

F02-508-09

5.8.2 Drum Cleaner Unit

a. Construction

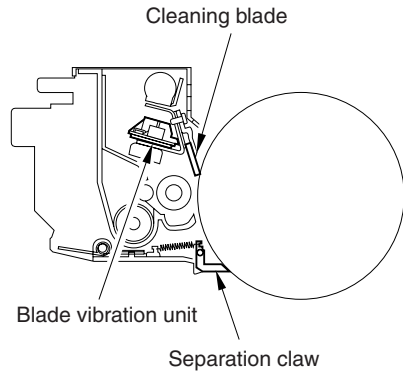

F02-508-10

b. Removing the Cleaning Blade

- 1) Slide out the process unit.
- 2) Remove the screw [1], and detach the reciprocating arm [2].

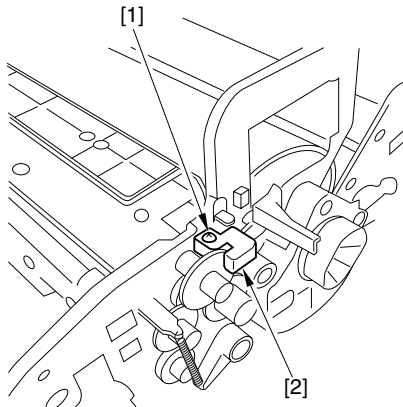

F02-508-11

- 3) Disconnect the 2 connectors [1], and remove the 5 screws [2]; then, lift the rear and push it in to detach the cleaning blade together with the mounting plate [3].

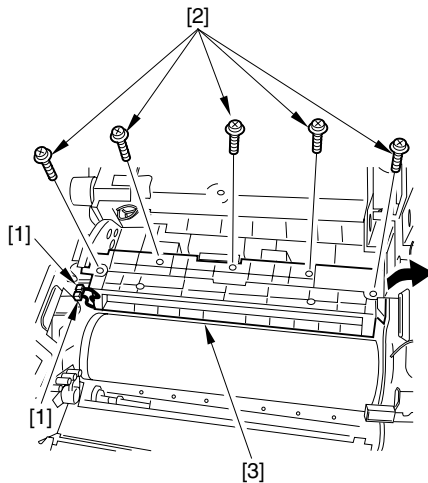

F02-508-12

- 4) Remove the E-ring [1], and detach the pressure plate [2] to detach the cleaning blade assembly [3].



The pressure plate looks like the one used for the GP600 Sires or iR8500 Series machines; however, it is a different part with a different parts number. Do not use the wrong part.

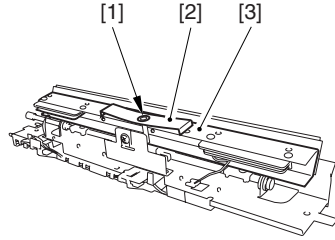

F02-508-13

- 5) Remove the 5 screws [1], and detach the blade retaining plate [2] to detach the cleaning blade [3].

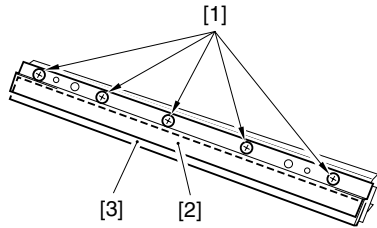

F02-508-14

c. Mounting the Cleaning Blade
See Chapter 5.

d. Removing the Blade Vibrating Unit

- 1) Remove the blade unit.
- 2) Disconnect the connector [1], and remove the 2 screws [2]; then, detach the blade vibrating unit [3].
(The rear and front blade vibrating units may be disassembled in the same way.)

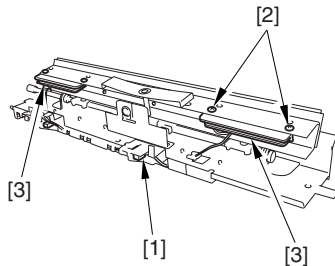

F02-508-15

5.8.3 Charging Wires

a. Outline

As many as 3 charging wires are found around the photosensitive drum (primary, pre-transfer, transfer/separation); these wires are 0.06 mm in diameter.

b. Removing the Wire Cleaner for the Primary Charging Assembly

- 1) Remove the primary charging assembly.
- 2) Move the clip base [1] fully to the rear, and remove the screw [2]; then, remove the support plate [4] of the wire clean motor shaft [3], and detach the clip base [1] from the cut-off [6] of the shielding plate [5] together with the wire cleaner motor shaft [3].

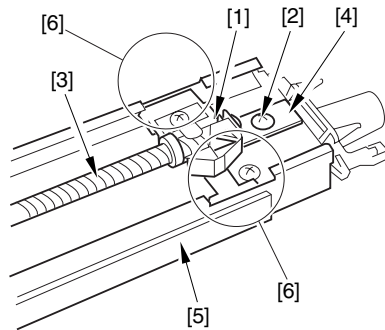

F02-508-16

- 3) Pick the wire cleaner with small pliers, and free the hook with your fingers.

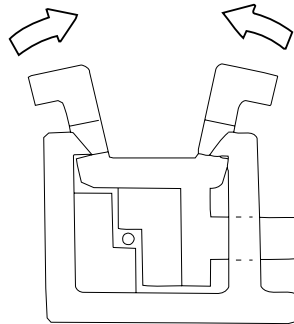

F02-508-17

c. Stringing the Charging Wire

As a rule, the charging wire (except the grid wire) may be strung in the same way for all charging assemblies. The following uses the primary charging assembly as an example:

- 1) Remove the 2 screws [1], and detach the shielding plate (left, right) [2] of the charging assembly.
To prevent deformation (slack) of the primary charging assembly, be sure to work on the left and right shielding plates separately. (Do not loosen the screw for the left/right shielding plate.)
- 2) Remove the wire cleaner.

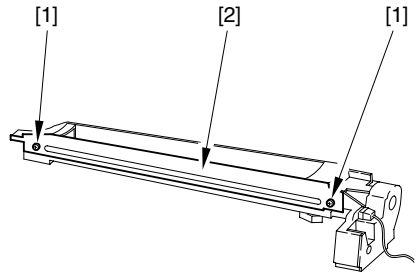

F02-508-18



For other charging assemblies, remove the lid (2 pc.)

- 3) Free a length of about 5 cm from a charging wire reel (wire dia. of 0.06 mm), and form a loop at the end about 2 mm in diameter.



To form a loop, wind the charging wire once around a hex key, and twist the key 3 to 4 times.

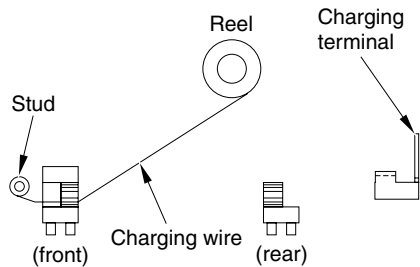

F02-508-19

- 4) Cut the end (excess) for the twisted charging wire.
- 5) Hook the loop on the stud.
- 6) Hook the charging wire on the charging wire positioner at the rear, and hook the charging wire tension spring on the charging wire, and twist it.

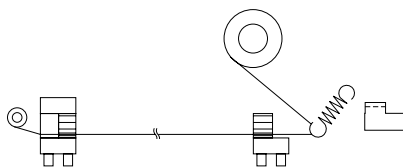

F02-508-20

- 7) Cut the excess of the charging wire with a nipper.
- 8) Pick the end of the charging wire tension spring with tweezers, and hook it on the charging wire terminal. In the case of the pre-transfer charging assembly, hook the spring at the front.

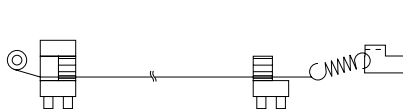

F02-508-21



Be sure of the following:

- The charging wire is free of bends and twists.
- The charging wire is in the bottom of the V-groove of the charging wire positioner.

Grid side

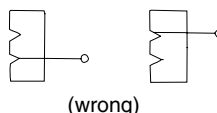
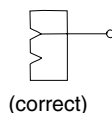

F02-508-22

- 9) Fit the cushion to the front of the charging wire. (except for primary charging assembly)
- 10) Mount the shielding plate (left, right).



For other charging assemblies, fit the lid (2 pc.).



After stringing the charging wire of each charging assembly, check to make sure that the length of the tension spring is as follows:

Primary charging assembly	$A=12.0\pm 1\text{mm}$	
Pre-transfer charging assembly	$A=12.0\pm 1\text{mm}$	
Transfer charging assembly	$A=12.0\pm 0.5\text{mm}$	
Separation charging assembly	$A=12.0\pm 0.5\text{mm}$	

- 11) Mount the wire cleaner. At this time, pay attention to the orientation of the wire cleaner.
- 12) Wipe the charging wire with lint-free paper moistened with alcohol.

d. Stringing the Grid of the Primary Charging Assembly

- 1) Check to make sure that the 4 screws used to keep the front/rear block and shielding plate are not loose. Then, hook the end of the charging wire on stud A, and then route it for 41 runs; then, hook it on B, C, and D; thereafter, fit it between the double washers [1], give a 1/2 turn around the screw [2], and secure it in place.

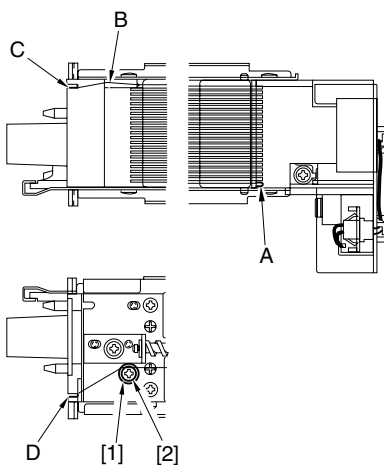

F02-508-23

- 2) Loosen the screws [1], [2], [3], [4]; then, tighten the screw [5] to a torque of $1.5 \pm 0.2 \text{ kg}\cdot\text{cm}$. thereafter, tighten the screws [1], [2], [3], [4] to a torque of $8 \text{ kg}\cdot\text{cm}$ in the order indicated.

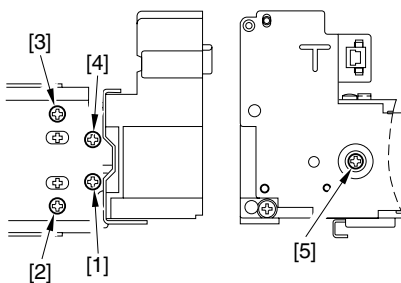

F02-508-24

e. Adjusting the Height of the Charging Wire

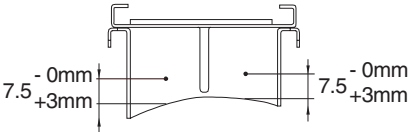
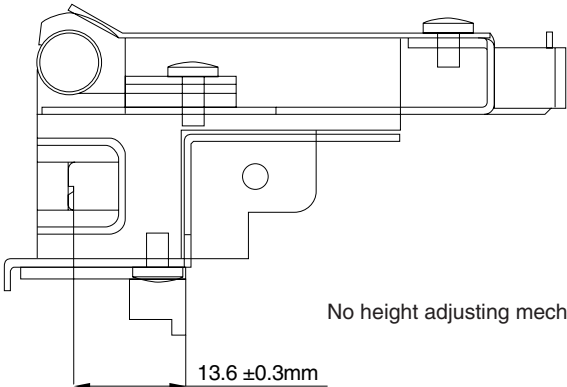
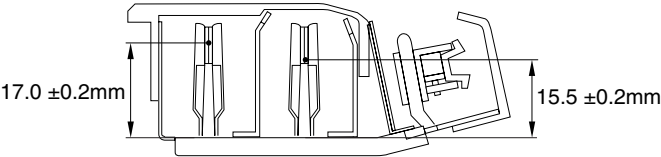
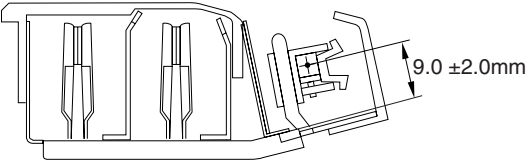
Charging assembly	Height of charging wire
Primary	
Pre-transfer	 <p data-bbox="696 727 994 751">No height adjusting mechanism</p>
Separation	
Transfer	

F02-508-25



The height (position) of the primary and transfer charging wires may be adjusted by turning the screw found at the rear of the charging assembly. A full turn of the screw changes the position of the charging wire by about 0.7 mm.

5.8.4 Area Around the Process Unit

a. Removing the Pre-Transfer Exposure LED

- 1) Slide out the pre-transfer charging assembly.



When placing the removed pre-transfer charging assembly, be sure to take care not to subject the LED to impact.

- 2) Turn over the pre-transfer charging assembly, and remove the 3 screws [1] found on the bottom; then, detach the LED cover [2].

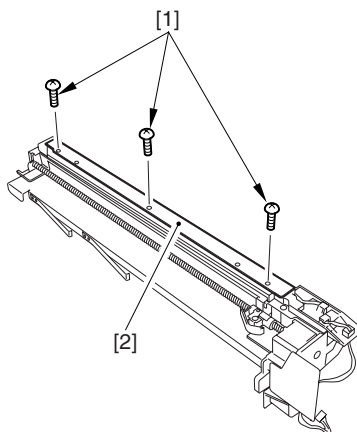

F02-508-26

- 3) Disconnect the connector [1], and remove the pre-transfer exposure LED [2].

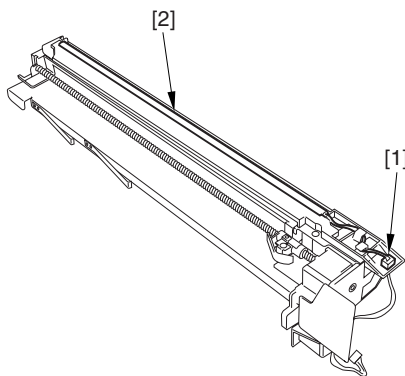

F02-508-27

b. Remove the Developing Cylinder Deceleration Clutch

- 1) Remove the high-voltage transformer (DC) assembly. (See 8.4.7.c.)
- 2) Remove the flywheel.
- 3) Disconnect the 2 connectors [1], and remove the 5 screws [2]; then, detach the clutch mounting plate [3].

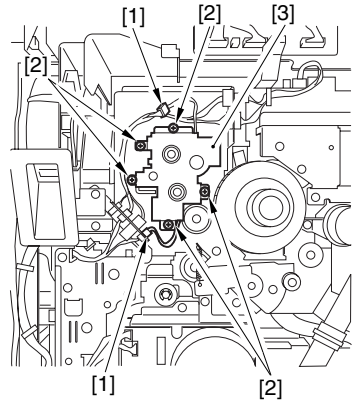

F02-508-28

- 4) Remove the heater developing cylinder deceleration clutch [1].

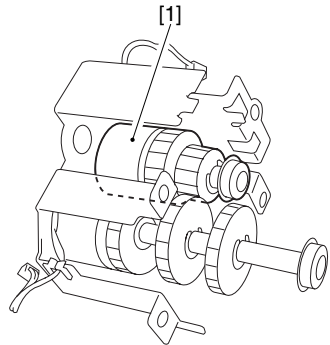

F02-508-29

- 5) Remove the 6 E-rings [1], 2 bearings [2], gear [3], and pin [4]; then, detach the clutch [5].

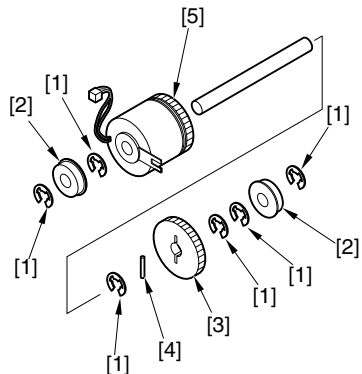

F02-508-30

c. Remove the Developing Cylinder Clutch

- 1) Remove the clutch mounting plate.
- 2) Take out the developing cylinder clutch [1].

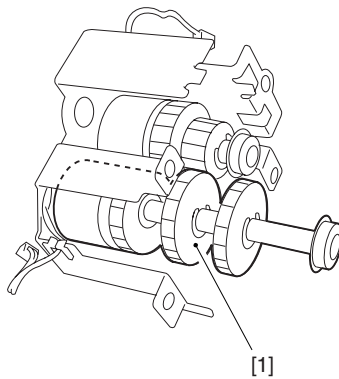

F02-508-31

- 3) Remove the 8 E-rings [1], 2 beatings [2], 2 gears [3], and pin [4]; then, detach the clutch [5].

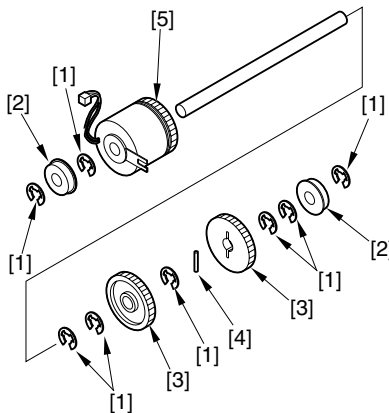

F02-508-32

6 Pickup/Feeding System

6.1 Outline of the Pickup/Feeding System

The major changes made to the pickup/feeding system are as follows:

- To support the increased speed in the process (500 mm/sec), an optical sensor is used instead of a photointerrupter for the following: right/left deck pickup sensor, right/left feed sensor, cassette 3/4 pickup sensor, vertical path 3/4 sensor.
- The use of index paper is allowed as a transfer medium.

For others, see T02-602-01 and T02-602-02.

6.2 Changes Made to the Pickup/Feeding System

Unit/location	Changes from GP605 (IR600)	Propose of change	Remarks	Reference
Pickup roller	Changed the material.	To support higher speed of operation.		
Separation roller	Changed the material.	To support higher speed of operation.		
Static eliminator	Added a static eliminator.	To suppress noise; for grounding of the pull-off roller.	Upward compatible;	
Manual feed tray assembly	Added a noise damper.	To suppress noise caused by impact occurring at time of release of the pick roller.	right deck, cassette. 3/4.	
Registration roller assembly	Changed the registration brake clutch.	To use a set screw for the joint between shaft and clutch, thereby preventing variation in the leading edge registration during high-speed operation.		
	Changed the shape of the registration cover roller.	To accommodate the change in the speed of the shaft caused by the use of a set screw stop clutch.		
	Changed the shape of the registration clutch cover.	To accommodate the shape of the cover caused by the use of a set screw clutch.		
	Added a bearing coupling gear.	To suppress the wobbling of the gear by fitting the bearing by force into the coupling, thereby eliminating the variation in the transmission of the drive caused by fluctuations in the load in the coupling (of the registration transfer assembly).		
Index paper attachment	To support the use of index paper.	To support the use of index paper. (The attachment is made available as an option.)		6.5 Index Paper Attachment

T02-602-01

Unit/location	Changes from GP605 (IR600)	Purpose of change	Remarks	Reference
Sensor	Made to use an optical sensor as the right/left deck pickup sensor. Made to use an optical sensor as the right/left deck feed sensor. Made to use optical sensors as the vertical path 3/4 sensors. Eliminated the U-turn sensor. Eliminated the reversal sensor.	To support high-speed operation.	A prism is mounted in the opposite side.	
	Added a duplex outlet sensor.	To support the design in which the duplex outlet sensor is used as the point of reference.		
	Added a duplex outlet sensor.	To support the design in which the duplex reversal sensor is used as the point of reference.		
	Added a duplex outlet sensor.	To ensure accurate movement of paper coming from the vertical path assembly at high accuracy by correctly identifying the position of the paper from the duplex feeding assembly.		
	Added an image write start sensor	To enable the shortest possible sheet-to-sheet distance.		
Torque limiter of separation roller	Increased the torque.	To ensure separation.		

T02-602-02

6.3 Optical Sensors

To accommodate the increase in the process speed, the machine uses a combination of an optical sensor [1] and a prism [2] instead of a photo sensor and a sensor flag for some of the sensors in the pickup/feeding assembly, thus ensuring correct detection of paper. (For the position of the sensors, see F02-604-01.)

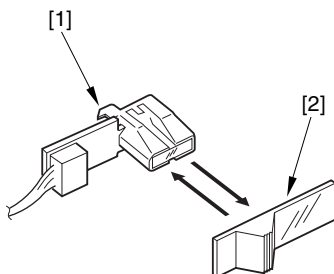

F02-603-01

6.4 Image Write Start Sensor

The image write start sensor is used to support the increased speed of operation. It detects the leading edge of paper before it reaches the registration roller, preparing the printer for printing operation. The presence of this sensor enables the shortest possible sheet-to-sheet distance. (For the position for the sensor, see F02-604-01.)

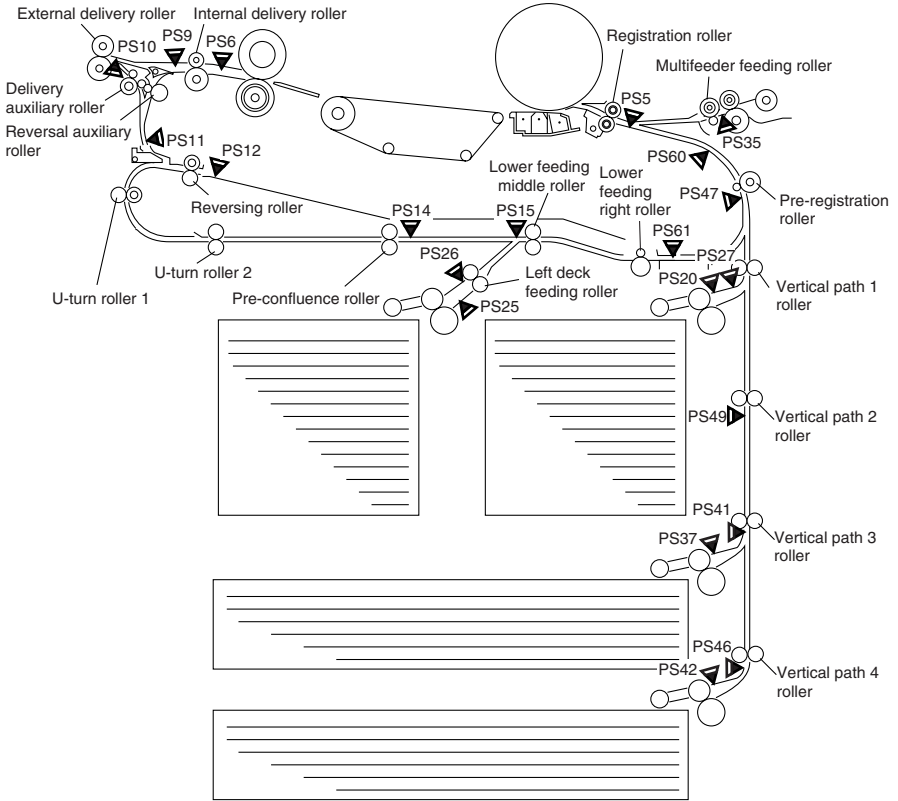

- PS5: registration sensor
- PS6: claw jam sensor
- PS9: internal delivery sensor
- PS10: external delivery sensor
- PS11: fixing/feeding outlet sensor
- PS12: duplex reversal sensor
- PS14: pre-confluence reversal sensor
- PS15: post-confluence sensor
- PS20: right deck pickup sensor*
- PS25: left deck pickup sensor*
- PS26: left deck feed sensor*

- PS27: right deck feed sensor*
- PS35: multifeeder pickup sensor
- PS37: cassette 3 pickup sensor*
- PS41: vertical path 3 sensor*
- PS42: cassette 4 pickup sensor*
- PS46: vertical path 4 sensor *
- PS47: vertical path 1 sensor
- PS49: vertical path 2 sensor
- PS60: image write start sensor
- PS61: duplex outlet sensor
- * Optical sensor.

F02-604-01

6.5 Index Paper Attachment

The machine allows the use of index paper as a transfer medium. Start user mode, and select index paper copy mode and fit an Index Paper Attachment-A1 (option; F02-605-01) so that an index sheet may be inserted between copy sheets (index sheet insert mode) or print in the index area (index production mode).

Index sheets are fed from the source of index sheets (cassette 3/4) selected from the control panel. (For details, see the User Guide.)

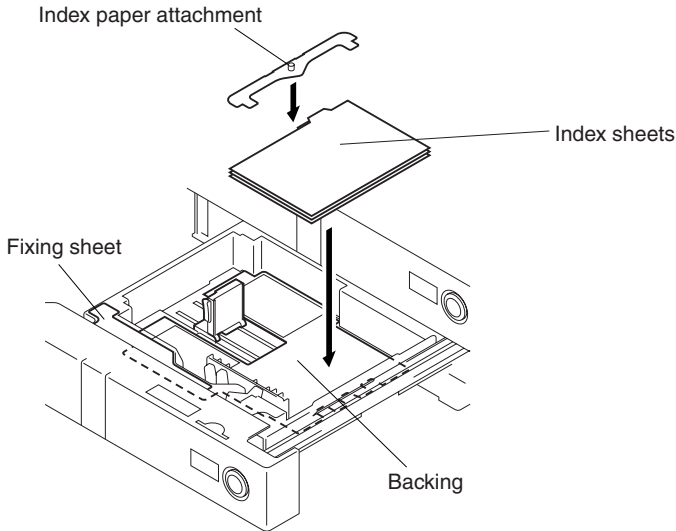

F02-605-01

6.6 Disassembly/Assembly

The mechanical characteristics of the machine are as described herein; disassemble/assemble the machine as instructed and with the following in mind:

1.  Before starting any disassembly/assembly work, turn off the main power switch, and disconnect the power plug.
2. Unless otherwise specifically instructed, assemble the machine by reversing the steps used to disassemble it.
3. Identify the screws by type (length, diameter) and location.
4. To protect against static charge, one of the mounting screws of the rear cover comes with a toothed washer. Be sure not to leave out the washer when assembling the machine.
5. To ensure electrical continuity, the mounting screw for the grounding wire and the varistor comes with a washer. Be sure not to leave out the washer when assembling the machine.
6. As a rule, do not operate the machine with any of its parts removed.
7. When sliding out the duplex feeder unit or the fixing assembly, be sure to turn off the front cover switch or the power switch.

6.6.1 Manual Feed Tray Assembly

a. Removing the Manual Feed Tray Unit

- 1) Remove the control panel unit. (See 8.4.2.a.)
- 2) Remove the upper right cover.
- 3) Open the manual feed tray unit [1].
- 4) Remove the screw [2], and detach the door tape [3] from the machine side.
- 5) Remove the screw [4], and detach the connector cover [5].
- 6) Disconnect the connector [6], and detach the manual feed tray unit [1] upward while it is kept open at about 90°.

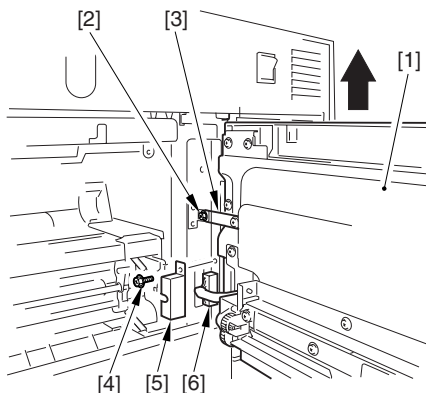

F02-606-01

b. Fitting the Side Guide Timing Belt for the Manual Feed Tray Assembly

- 1) Butt the rack plate [1] of the manual feed tray against section A (in open state).
- 2) Move the slide volume [2] in the direction of B, and fit the timing belt [3] to the pulley [4] and the pulley [5].

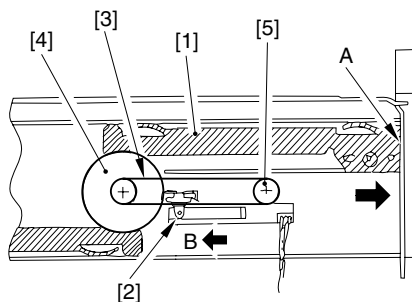

F02-606-02

c. Removing the Manual Feed Tray Paper Sensor

- 1) Open the manual feed tray unit, and remove the door tape from the machine side.
- 2) Remove the mounting screw [1], and detach the solenoid cover [3]. (A claw [2] is hooked on the L-shaped opening; pull it down lightly, and move it as if to open it.)

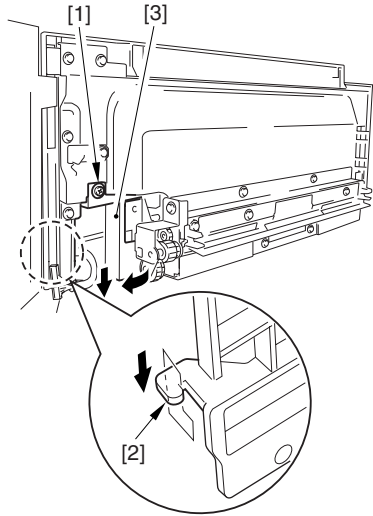

F02-606-03

- 3) Disconnect the connector [1].
- 4) Remove heater mounting screw [2], and detach the pickup roller releasing solenoid [3] together with the support plate.

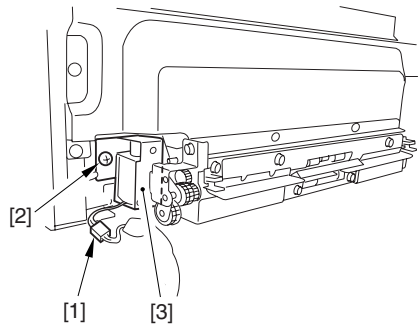

F02-606-04

- 5) Remove the screw [1], and detach the connector cover [2]; then, disconnect the connector [3].

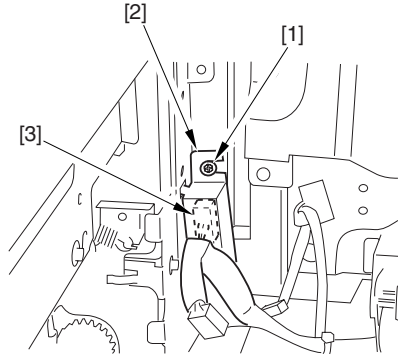

F02-606-05

- 6) Open the manual feed tray.
7) Remove the 11 mounting screws [1], and detach the manual feed tray pickup assembly [2].

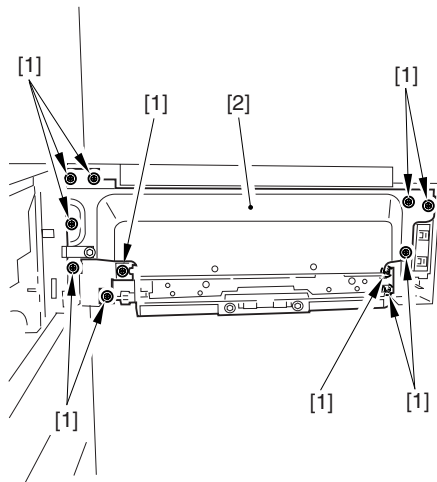

F02-606-06

- 8) Remove the 2 mounting screws [1], and detach the upper guide plate [2].

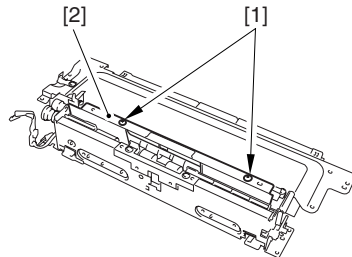

F02-606-07

- 9) Remove the 2 mounting screws [1] found at the bottom, and detach the lower cover [2].

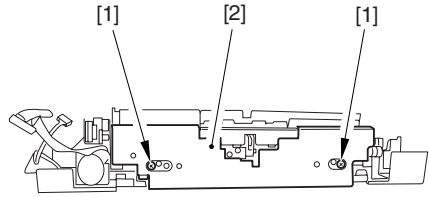

F02-606-08

- 10) Remove the 2 mounting screws [1], and detach the middle guide plate [2].

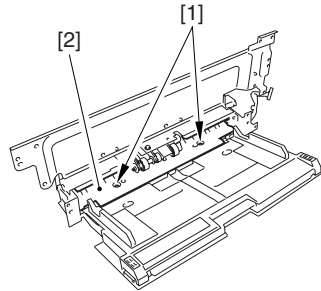

F02-606-09

- 11) Remove the 2 mounting screws [2] of the sensor unit [1].

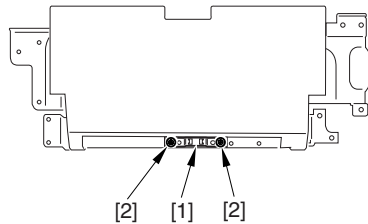

F02-606-10

- 12) Disconnect the connector [1], and detach the sensor unit [2].
- 13) Remove the sensor [3] from the sensor unit [2].

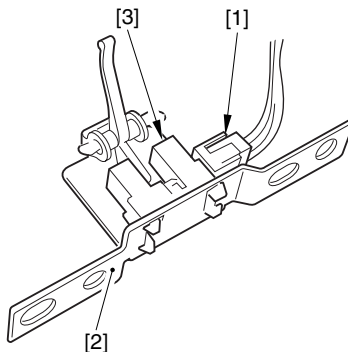

F02-606-11

6.6.2 Cassette Pickup Assembly

a. Removing the Left Deck Pickup Sensor

- 1) Remove the front deck (left) pickup assembly.
- 2) Remove the screw [1], and detach the pickup sensor unit [2].

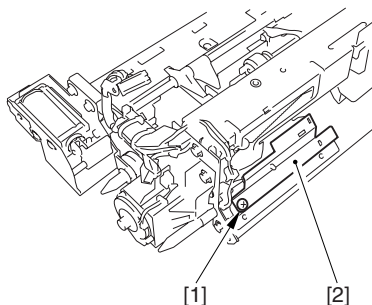

F02-606-12

- 3) Disconnect the connector [1], and detach the left deck pickup sensor [2].



When removing the scanner sensor, be sure to remove the paint used to lock the claw in place in advance to prevent breaking the claw. When mounting it, be sure the claw is not displaced or the sensor is not disoriented.

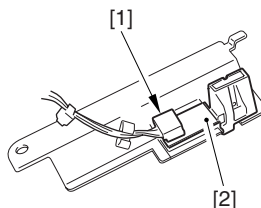

F02-606-13

b. Removing the Right Deck Feed Sensor/Right Deck Pickup Sensor

- 1) Remove the front deck (right) pickup assembly.
- 2) Remove the guide plate [1].

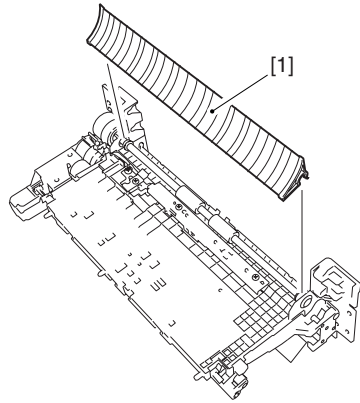

F02-606-14

- 3) Remove the screw [1], and detach the stack eliminator [2].
- 4) Remove the 2 screws [3], and detach the pickup assembly sensor base [4].

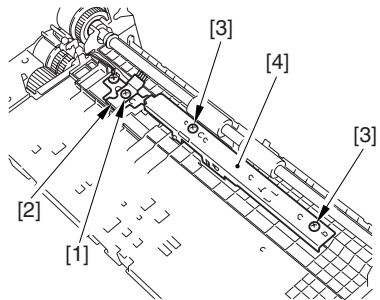

F02-606-15

- 5) Disconnect the connector [1] (1 pc. each), and free the claw; then, detach the right deck feed sensor [2] and the right deck pickup sensor [3].



When removing the scanner sensor, be sure to remove the paint used to lock the claw in place in advance to prevent breaking the claw. When mounting it, be sure the claw is not displaced or the sensor is not disoriented.

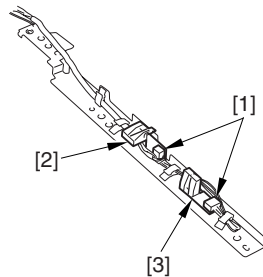

F02-606-16

c. Removing the Vertical Path 3/4 Sensor and the Cassette 3/4 Pickup Sensor

- 1) Remove the cassette 3/4 pickup assembly.
- 2) Remove the screw, and detach the static eliminator [2].
- 3) Remove the screw [3], and detach the pickup assembly sensor base.

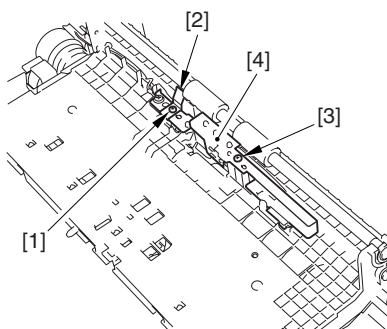

F02-606-17

- 4) Disconnect the connector [1] (1 pc. each), and free the claw; then, detach the vertical path 3/4 sensor [2] and the cassette 3/4 pickup sensor [3].

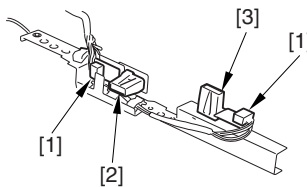

F02-606-18

6.6.3 Vertical Path Roller Assembly

a. Removing the Vertical Path Roller 1/3/4

- 1) Remove the deck right/cassette pickup assembly.
- 2) Remove the E-ring [1] and the bearing [2] from the front, and remove the grip ring [3], clutch [4], and bearing [5] from the rear.

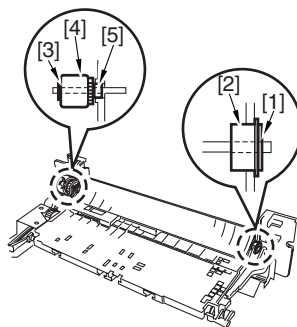

F02-606-19

- 3) Remove the E-ring [1] of the front and the rear of the roller shaft, and move the bearings [2] toward the inside; then, detach the guide plate [3].

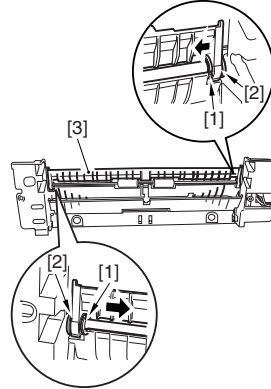

F02-606-20

- 4) Remove the E-ring [1], and remove the bearing [2] to detach the vertical path roller [3].

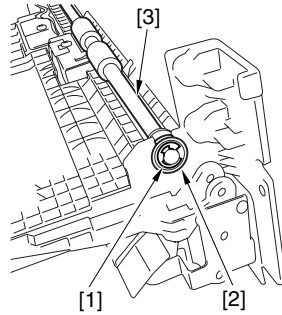

F02-606-21

b. Removing the Vertical Path Roller 2

- 1) Slide out the deck (right) and the caste 3/4.
- 2) Remove the 3 screws [1], and detach the right lower front cover [2].

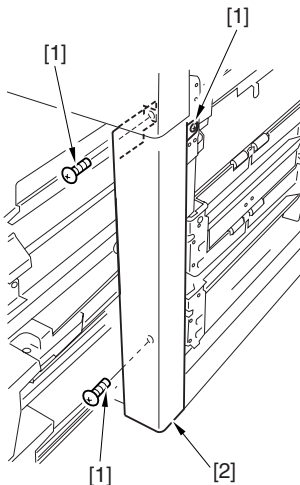

F02-606-22

- 3) Disconnect the connector [1] and the screw [2]; then, detach the guide plate [3].

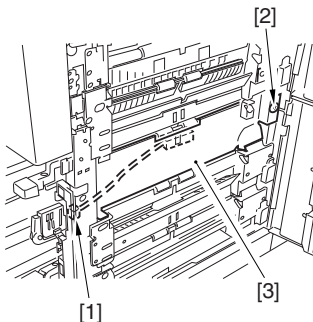

F02-606-23

- 4) Remove the E-ring [1] at the front of the roller shaft, and move the bearing [2] toward the inside; then, detach the vertical path roller 2 [3].

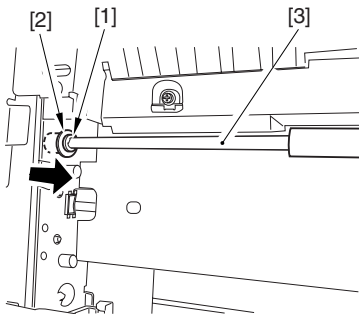

F02-606-24

6.6.4 Registration Feed Assembly

a. Removing the Registration Clutch

- 1) Remove the fixing/feed unit.
- 2) Shift up the releasing lever.
- 3) Disconnect the connector [1], and detach the harness of the clutch from the clutch cover [2].
- 4) Remove the screw [3], and detach the clutch cover [2] and the bearing [4].

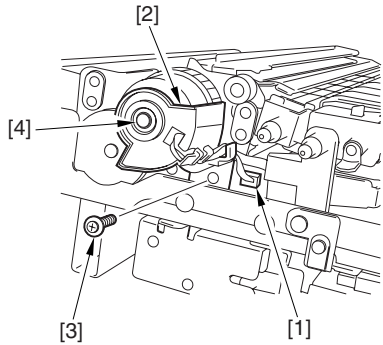

F02-606-25

- 5) Loosen the 2 adjusting screws [1], and detach the registration clutch [2].

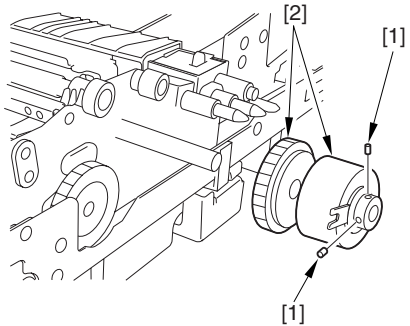

F02-606-26



When mounting the registration clutch, be sure to hook the clutch stop [A] on the protrusion [B] of the clutch cover.

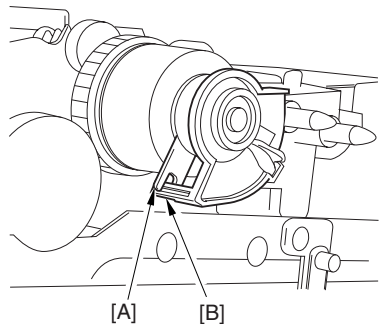

F02-606-27

b. Removing the Registration Brake Clutch

- 1) Remove the transfer separation charging assembly front cover. (1 screw)
- 2) Disconnect the connector [1], and loosen the 2 screws [2] (w/ hex hole); then, detach the registration brake clutch [3].

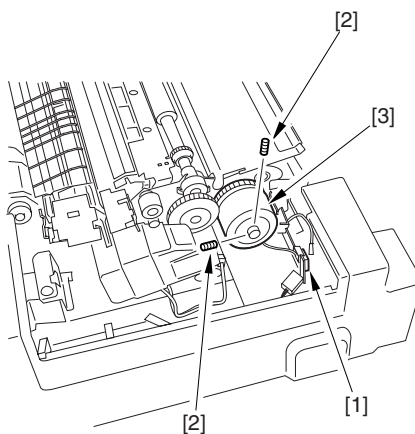

F02-606-28

6.6.5 Duplex Unit

a. Removing the Reversal Motor

- 1) Remove the duplex feed fan unit. (See 8.4.3.r.)
- 2) Loosen the screw [1]; then, while pulling the tension support plate [2] in the direction of the arrow, tighten the screw [1] (to loosen the tension of the belt [2]).
- 3) Disconnect the connector [4], and remove the 2 screws [5]; then, detach the reversal motor [6].

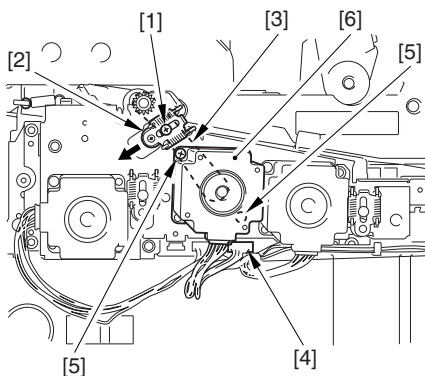

F02-606-29

b. Removing the Duplex Left Feed Motor

- 1) Remove the duplex feed fan unit. (See 8.4.3.r.)
- 2) Loosen the screw [1]; then, while pulling the tension support plate [2] in the direction of the arrow, tighten the screw [1] (to loosen the tension of the belt [3]).
- 3) Disconnect the connector [4], and remove the 2 screws [5]; then, detach the duplex left feed motor [6].

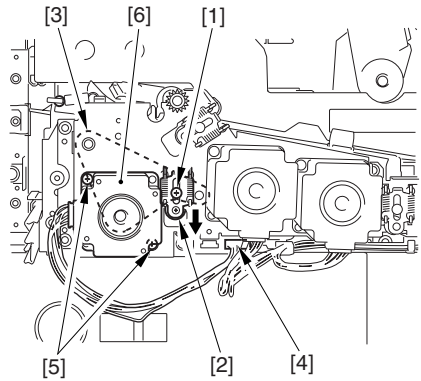

F02-606-30

c. Removing the Duplex Right Feed Motor

- 1) Remove the front cover of the duplex unit. (4 screws, 3 knobs)
- 2) Loosen the screw [1]; then, while pulling the tension support plate [2] in the direction of the arrow, tighten the screw [1] (to loosen the tension of the belt [3]).
- 3) Disconnect the connector [4], and remove the 2 screws [5]; then, detach the duplex right feed motor [6].

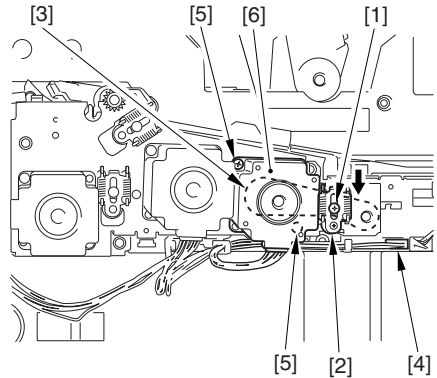

F02-606-31

d. Removing the Left Deck Feed Sensor

- 1) Slide out the duplex unit assembly.
- 2) Remove the screw [1], and detach the sensor base [2].

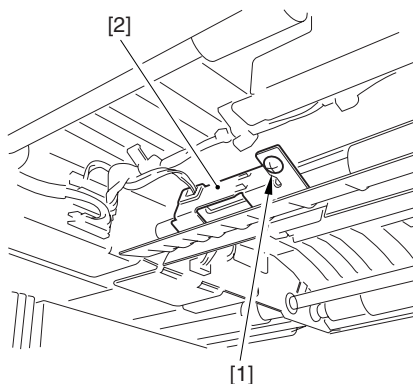

F02-606-32

- 3) Disconnect the connector [1], and free the claw to detach the left deck feed sensor [2].



When removing the scanner sensor, be sure to remove the paint used to lock the claw in place in advance to prevent breaking the claw. When mounting it, be sure the claw is not displaced or the sensor is not disoriented.

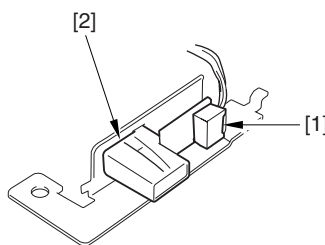

F02-606-33

6.6.6 Others

a. Removing the Fixing/Feed Unit

- 1) Slide out the fixing/feed unit.
- 2) Remove the 2 stepped screws [1].

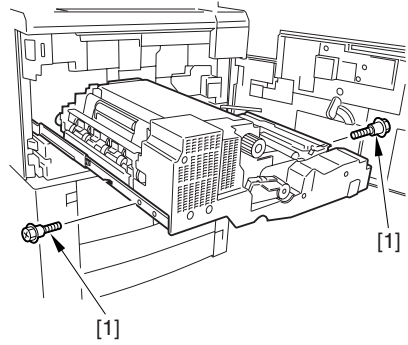

F02-606-34

- 3) Remove the fixing /feed unit [1] from the slide rail [2].



Be sure to work as a group of two.

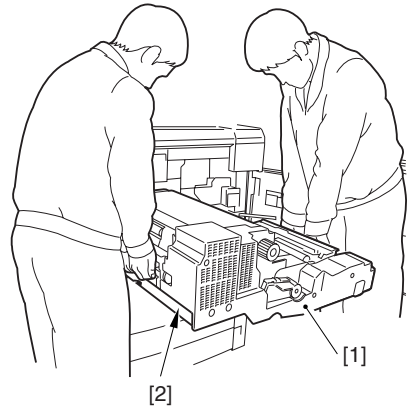

F02-606-35

Blank page

7 Fixing System

7.1 Outline of the Fixing System

The following are major changes made in relation to the fixing system:

- fixing temperature control (while paper is on the move, 188°C for 200V model, 198°C for 208V/230V model)
- fixing heater power

For others, see T02-702-01.

The major components of the fixing system are shown in F02-701-01 and F02-701-02.

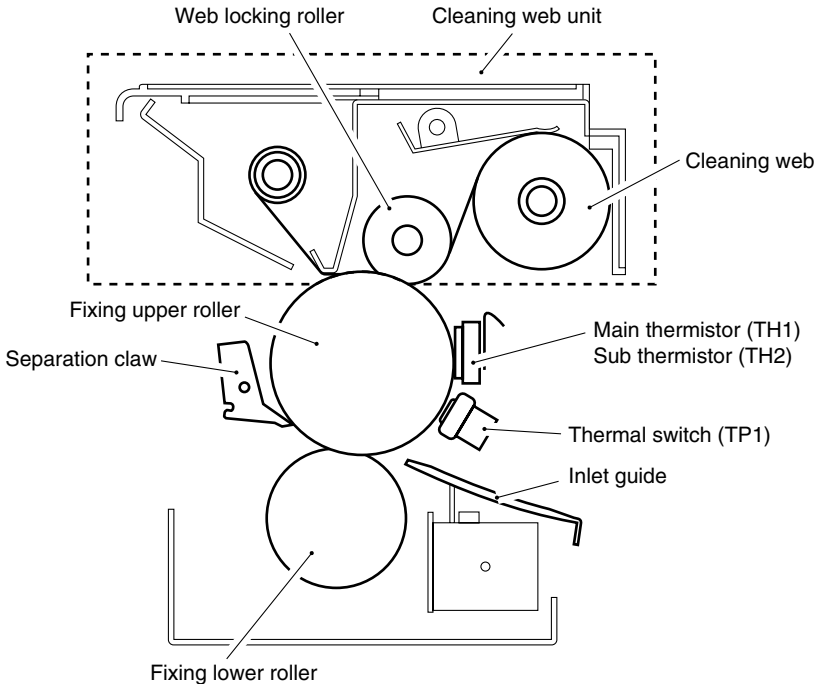

F02-701-01

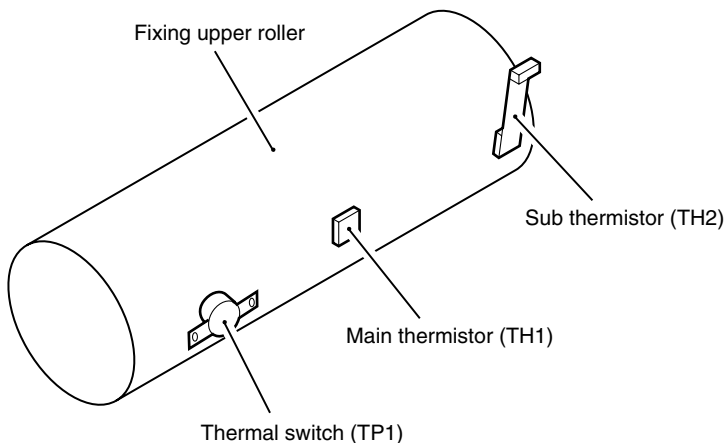

F02-701-02

Component	Notation	Description
Fixing upper roller		Heat roller, 60-mm dia.
Fixing lower roller		Pressure roller, 50-mm dia.
Fixing motor	M3	DC motor, 33 W
Main heater	H1	200V model: 1150 W 208V model: 1220 W 230V model: 1185 W
Sub heater	H2	200V model: 565 W 208V model: 600 W 230V model: 645 W
Main thermistor	TH1	Temperature control, error detection
Sub thermistor	TH2	Error detection
Thermal switch	TP1	Operating temperature: 228°C
Cleaning web		Driven by web drive solenoid (SL2); for large-size paper (B4 or larger), goes ON twice; for small-size paper (smaller than B4), goes on once
Inlet guide		Fixed

T02-701-01

7.2 Changes Made to the Fixing System

Unit/location	Changes from GP605 (IR600)	Purpose of change	Remarks	Reference
Fixing	Changed the diameter of the fixing roller (from 50 to 60 mm dia)	To support higher speed of operation.		
	Changed the diameter of the pressure roller (from 38 to 50 mm dia)	To support higher speed of operation.		
	Changed the diameter of the web locking roller (from 24 to 28 mm dia)	To prevent slippage of the thermistor.		
	Increased the pressure of the web locking roller by 1.5 times.	To prevent slippage of the thermistor.		
	Eliminated the insulating material for the pressure roller.	To accommodate the increase in the diameter of the pressure roller.		
	Fixed the inlet guide swing mechanism in place.	To enhance feeding performance and prevent wrinkling.		
	Changed the distance of the pressure roller static eliminator (from 1.5 to 4 mm)	To reduce soiling of the back of paper by the pressure roller.		
	Made to use temperature control for standby and paper passage.			
	Thermal switch.	To accommodate the change in the edge temperature of the fixing assembly (from 22.3°C to 228°C).		
		Increased the power supply (1715 W/200 V, 1820 W/208 V, 1830 W/230 V).	In the GP605 (IR600), 850 W (100 V/20 A model).	
Separation claw	Changed the location of the separation claw.	To reduce soiling of paper edges.		
	Changed the leading edge angle (from 70 μ to 30 μ)	To reduce claw jams.		
	Decreased the escape pressure of the holder.	To reduce wear on the roller.		
	Changed the shape of the bottom of the holder.	To reduce the wear on the roller.		
	Changed the shape for the claw stopper.	To reduce the water to the roller.		

T02-702-01

Unit/location	Changes from GP605 (IR600)	Purpose of change	Remarks	Reference
Delivery roller construction	Changed the number of internal delivery rollers (from 4 to 6).	To reduce curling.		
	Changed the number of external delivery rollers (from 4 to 6).	To reduce curling.		
	Changed the shape of the roller in the curl-reducing mechanism.	To reduce curling.		
Delivery roller material	Changed the material. (internal delivery, reversal auxiliary, curl-reducing roller)	To increase durability.		
Delivery	Eliminated the curl guide.	To accommodate the use of an external delivery roller with a collar.		
Duplex	Made to use the leading edge for the reversal sequence.	To accommodate the use of tab sheets.	In the GP605 (IR600), the reference is to the trailing edge.	
		To accommodate the use of tab sheets.		

T02-702-02

7.3 Fixing Temperature Control

F02-703-01 shows the basic sequence of operation sued of the fixing system:

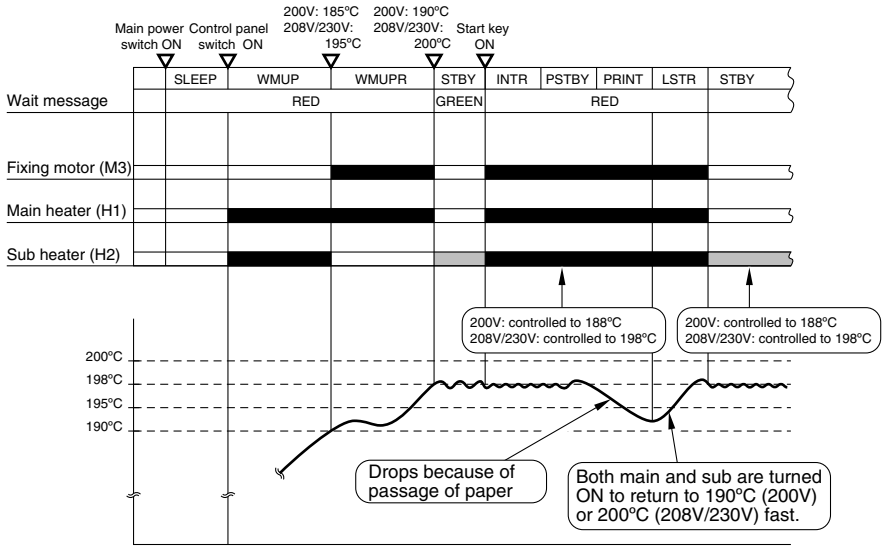

F02-703-01

7.4 Transparency Mode

To prevent wrapping of a transparency around the fixing roller (thus causing the transparency to melt because of heat of the fixing roller), the fixing roller temperature is reduced in transparency mode. F02-704-01 shows the sequence of operation used in transparency mode:

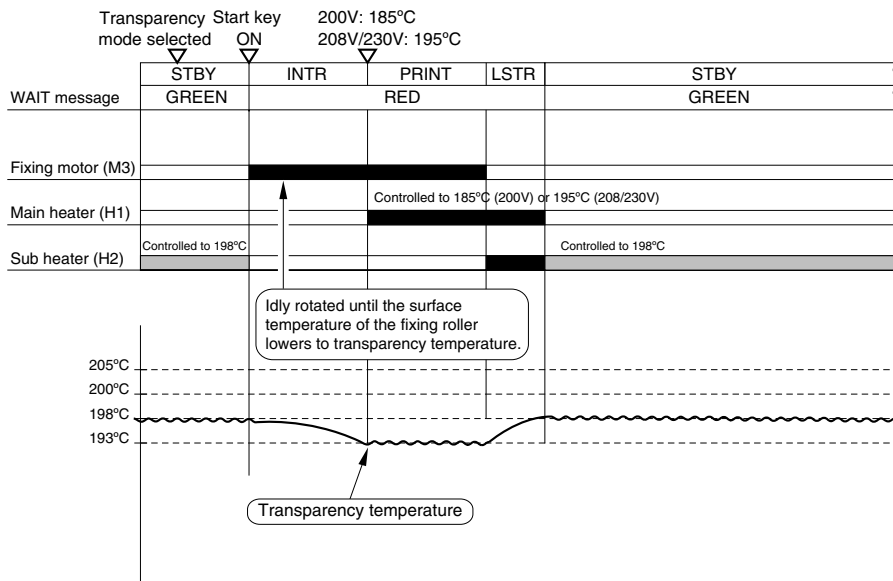

F02-704-01



COPIRE>OPTION>BODY>OHP-TEMP

(changing the temperature settings for the transparency mode)

0: 198°C (default)

1: 193°C

2: 188°C

3: 183°C

7.5 Thick Paper Mode

To prevent drops in the surface temperature of the fixing roller occurring when thick paper moves past it, the down sequence shift temperature increased.

If thick paper is selected when registering paper type in user mode (common settings), the down sequence for thick mode will be executed.



COPIRE>OPTION>BODY>FIX-TEMP

(setting the down sequence start temperature for thick paper mode)

Setting	86 cpm	74 cpm	Suspend	Resume
0	194°C	193°C	183°C	198°C
1	189°C	188°C	178°C	193°C
2	184°C	183°C	173°C	188°C

7.6 Power Save Mode

When the Power Save mode key is pressed in the control panel, the control temperature in STBY is made lower than normal to reduce power consumption. F02-706-01 shows the sequence of operation used in power save mode.

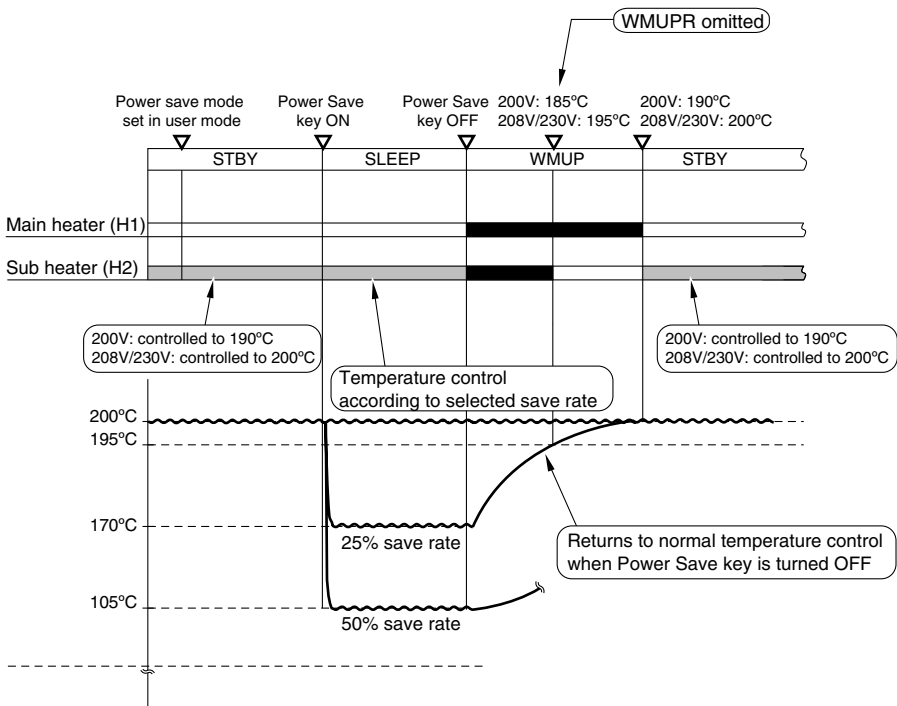

F02-706-01

7.7 Detecting an Error

The following errors are detected in relation to fixing temperature control:

1. temperature control error by main thermistor (TH1)
2. sensor error by sub thermistor (TH2)
3. overheating error by thermal switch (TP1)

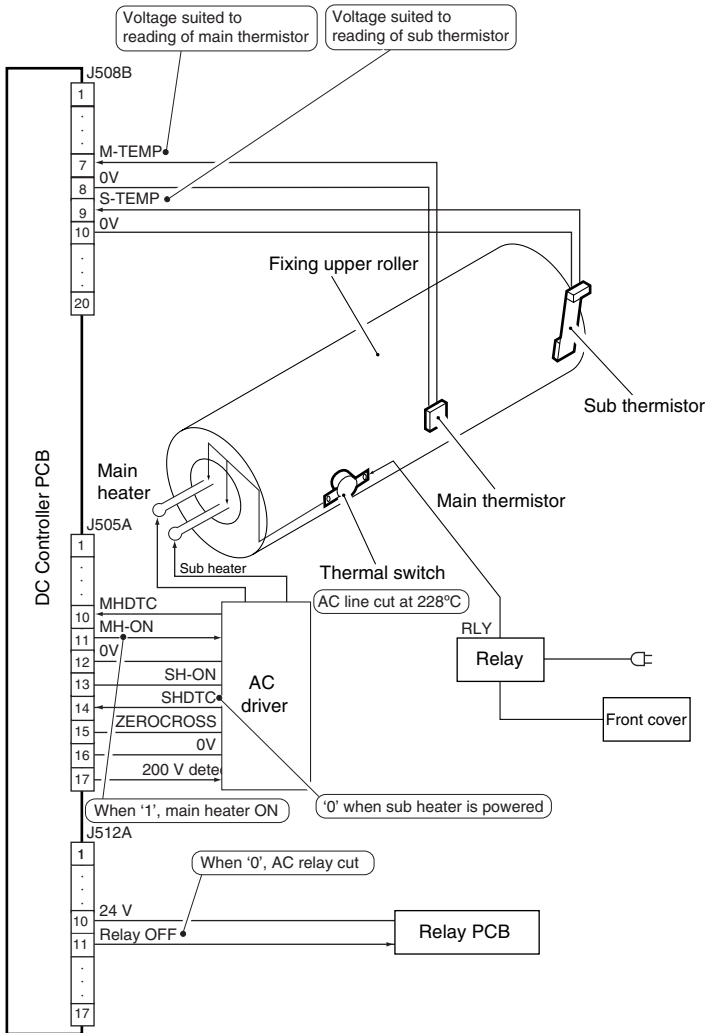

F02-707-01

7.8 Down Sequence Control

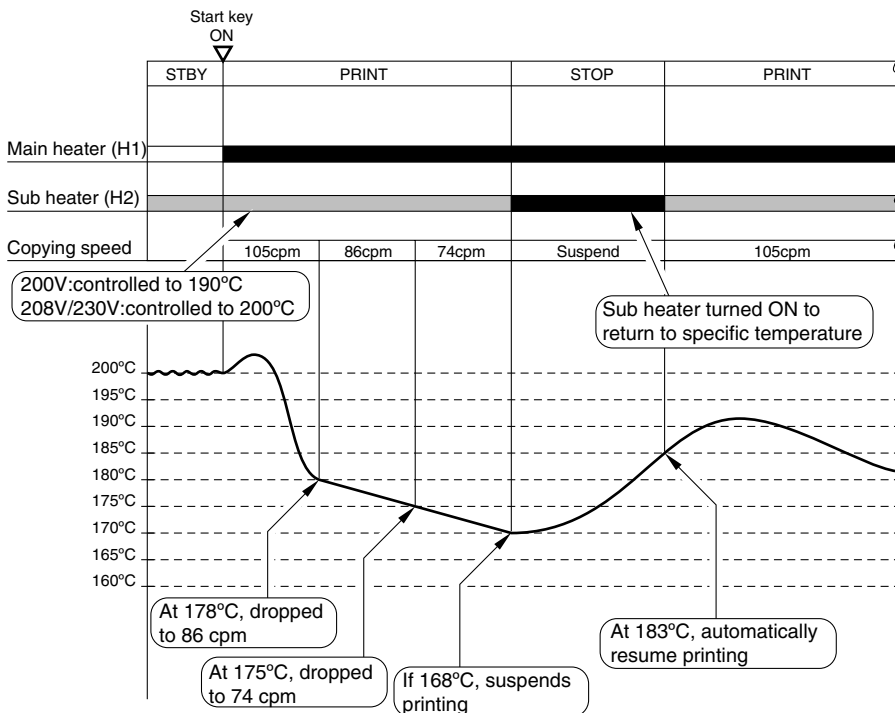

F02-708-01



COPIRE>OPTION>BODY>FIX-TMP1 (setting the down sequence)

Setting	86 cpm	74 cpm	Suspend	Resume
Setting 0	183°C	178°C	173°C	188°C
Setting 1 (default)	178°C	173°C	168°C	183°C
Setting 2	173°C	168°C	163°C	178°C

Select setting 0 if priority is on image quality; select setting 2 if priority is on speed.

7.9 Disassembly/Assembly

The mechanical characteristics of the machine are as described herein; disassemble/assemble the machine as instructed and with the following in mind:

1.  Before starting any disassembly/assembly work, turn off the main power switch, and disconnect the power plug.
2. Unless otherwise specifically instructed, assemble the machine by reversing the steps used to disassemble it.
3. Identify the screws by type (length, diameter) and location.
4. To protect against static charge, one of the mounting screws of the rear cover comes with a toothed washer. Be sure not to leave out the washer when assembling the machine.
5. To ensure electrical continuity, the mounting screw for the grounding wire and the varistor comes with a washer. Be sure not to leave out the washer when assembling the machine.
6. As a rule, do not operate the machine with any of its parts removed.
7. When sliding out the duplex feeder unit or the fixing assembly, be user to turn off the front cover switch or the power switch.

7.9.1 Fixing Heater and the Control Parts

a. Removing the Main/Sub Heater

- 1) Remove the fixing assembly.
- 2) Remove the 2 screws [1], and detach the fixing connector unit [2]; then, remove the screw [3] and the terminal plate [4] at the rear to pull out the faston [5]. (2 locations)

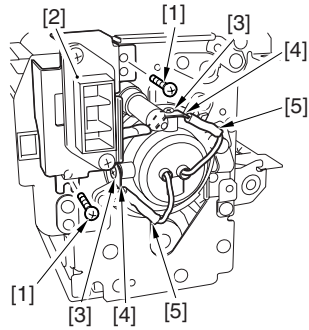

F02-709-01

- 3) Remove the 2 screw [1], and detach the heater positioning plate (rear) [2].

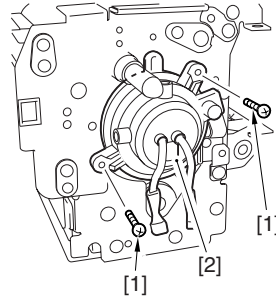

F02-709-02

- 4) Remove the 2 fastons [1] at the front, and remove the screw [2] to detach the heater positioning plate (front) [3].

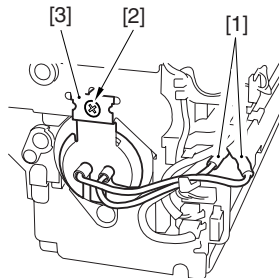

F02-709-03

- 5) Remove the main/sub heater.

b. Mounting the Main/Sub Heater

To mount the fixing heater, reverse the steps used to remove it with the following in mind:

- a. Do not touch the surface of the heater.
- b. For both, mount the heater so that the side with the longer harness is to the front.
- c. Viewing from the front of the fixing assembly, mount the main heater [1] to the right and the sub heater [2] to the left.

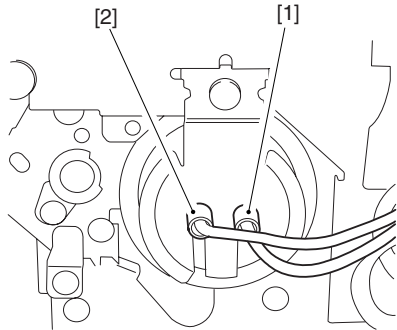

F02-709-04

c. Removing the Thermal Switch Unit

- 1) Remove the fixing assembly.
- 2) Remove the fixing web; then, remove the 2 screws [1] and the oil pan [2], and detach the fixing harness cover [3].

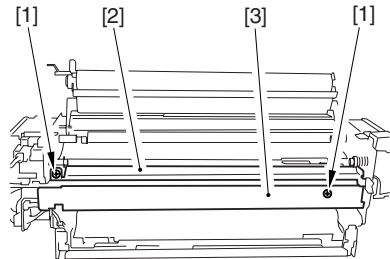

F02-709-05

- 3) Remove the faston [1], and remove the 2 screws [2]; then, detach the electrode assembly [3] and the thermal switch holder [4].

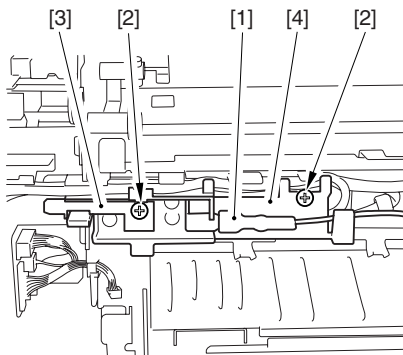

F02-709-06

- 4) Remove the 4 screws [1], and detach the thermal switch unit [2].

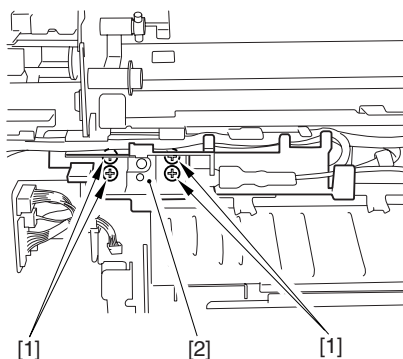

F02-709-07

d. Mounting the Thermal Switch Unit



- When mounting the thermal switch [1], be sure that it is in contact with the fixing roller [2] as shown.
- The thermal switch must be replaced as the thermal switch unit.
- Do not use again the thermal switch whose contact point become open.

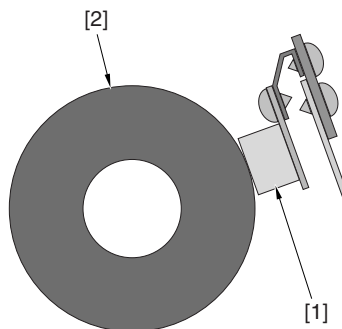

F02-709-08

e. Removing the Main Thermistor

- 1) Remove the fixing assembly.
- 2) Remove the fixing web and the oil pan.
- 3) Remove the fixing harness cover.
- 4) Disconnect the connector [1] of the thermistor. Remove the screw [2], and shift the thermistor assembly [3] to the rear to detach.



When shifting the thermistor assembly to the rear, take care not to damage the fixing roller with the thermistor.

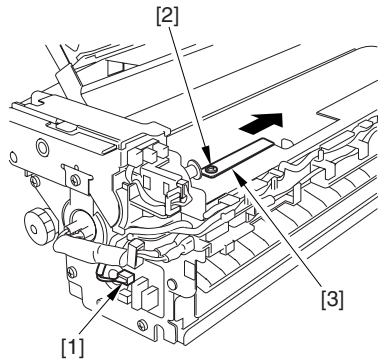

F02-709-09

- 5) Remove the 2 thermistor retaining springs [1], and detach the main thermistor [2].

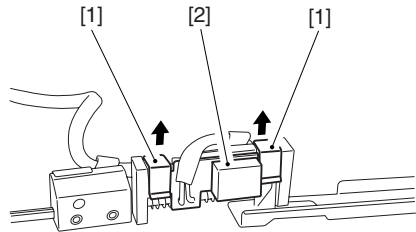

F02-709-10

f. Mounting the Main Thermistor

When mounting the main thermistor to the fixing assembly, be sure that the tie-wrap [1] is as shown.

The tie-wrap serves as a stopper by butting against the claw [2].

Check also to be sure that the main thermistor and the fixing roller are not away from each other.

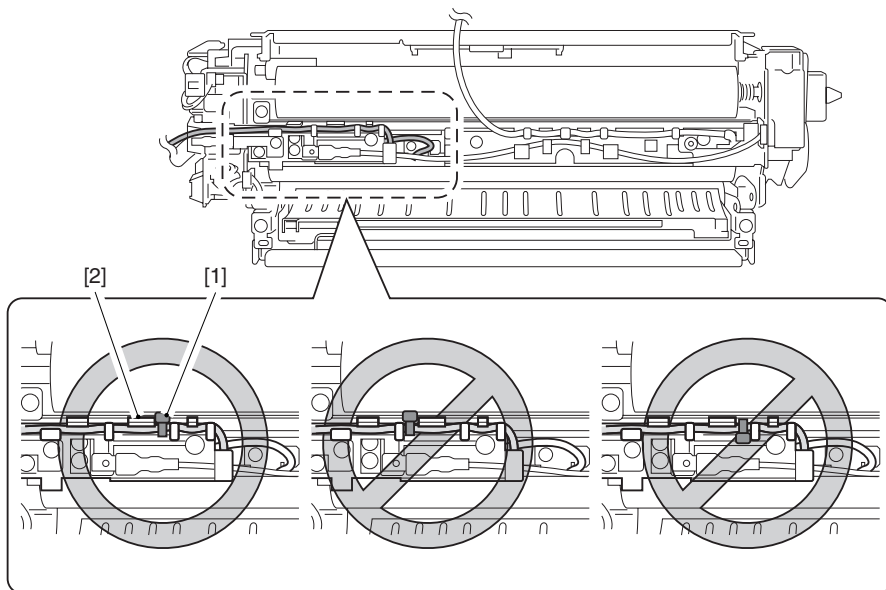

F02-709-11

g. Removing the Sub Thermistor

- 1) Slide out the fixing assembly.
- 2) Remove the fixing web and the oil pan.
- 3) Remove the fixing harness cover.
- 4) Disconnect the connector [1] and remove the screw [2]; then, detach the sub thermistor assembly [3].

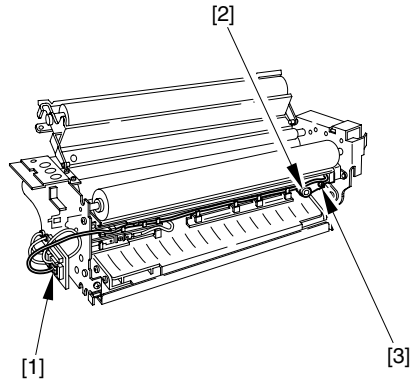

F02-709-12

- 5) Remove the screw [1], and detach the sub thermistor [2].

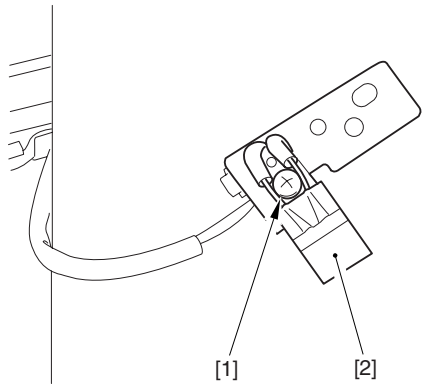

F02-709-13

7.9.2 Fixing Roller Assembly

a. Removing the Fixing Upper Roller

- 1) Remove the fixing assembly.
- 2) Remove the fixing web, and clean the oil pan.
- 3) Remove the 2 fixing heaters.
- 4) Remove the screw [1], and detach the pressure support plate [2] at the front.

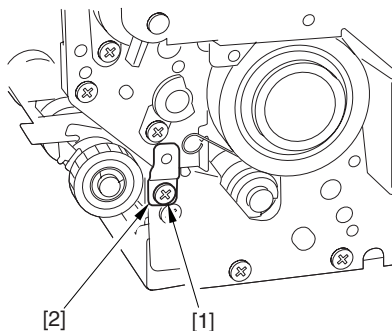

F02-709-14

- 5) Remove the screw, and detach the pressure support plate [2] at the rear.

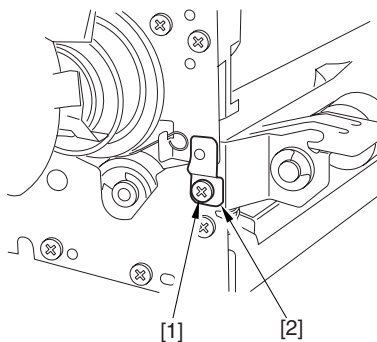

F02-709-15

- 6) Open the fixing upper unit [1].



When opened, the fixing upper unit becomes unstable. Be sure to use a screwdriver as shown to support it.

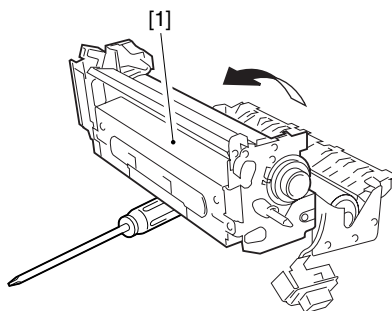

F02-709-16

- 7) Remove the stopper [1] from the front and the rear.

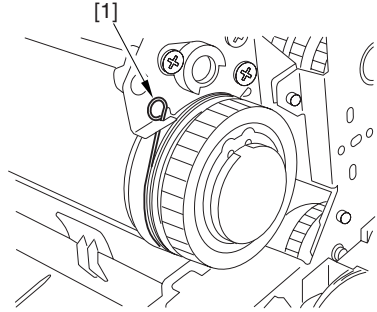

F02-709-17

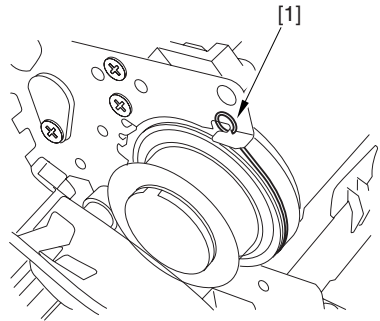

F02-709-18

- 8) While paying attention to the thermal switch and the thermistor, remove the upper roller assembly.
- 9) Remove the C-ring [1] at the front, and remove the gear [2], bushing [3], and bearing [4].

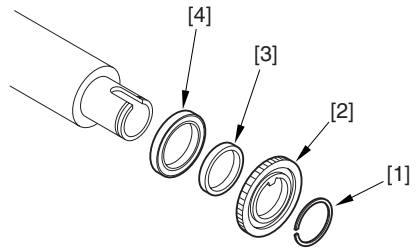

F02-709-19

- 10) Remove the C-ring [1] at the rear, and remove the electrode plate [2], spacer [3], bearing [4], and bushing [5].

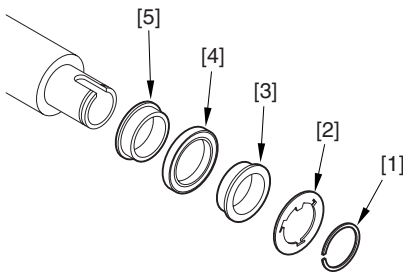

F02-709-20

b. Mounting the Fixing Upper Roller

Mount the upper roller by reversing the steps used to remove it.



- a. To prevent the surface of the roller from dirt or damage, wrap paper after removing it.
- b. Be sure that the longer cut-off A shown in F02-709-21 is toward the rear.
- c. When mounting, clean the electrode plate [1] and the electrode terminal [2].

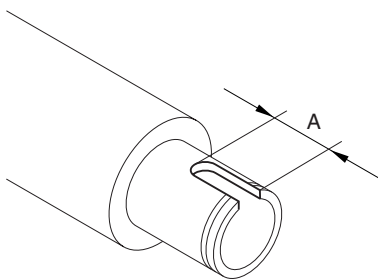

F02-709-21

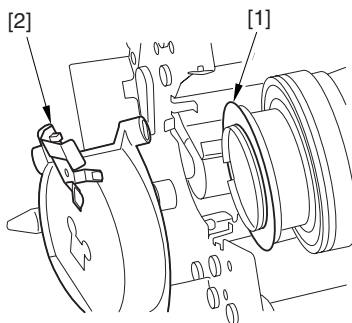

F02-709-22

7.9.3 Delivery Assembly

a. Removing the External Delivery Roller

- 1) Remove the fixing assembly.
- 2) Remove the 3 screws [1]; then, while opening the upper delivery assembly [2], remove the delivery roller guide [3].

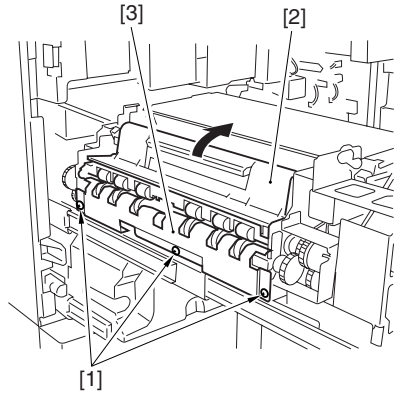

F02-709-23

- 3) Remove the E-ring [1] at the front, slide the bearing [2] in the direction of the gear.

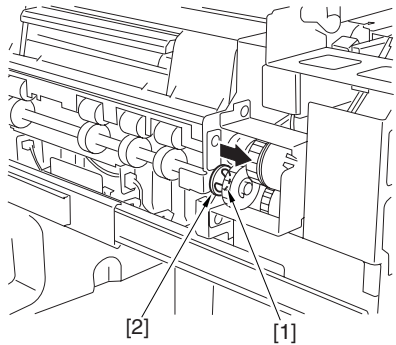

F02-709-24

- 4) Remove the E-ring [1], and slide the bearing [2] toward the rear; then, detach the external delivery roller assembly [3].

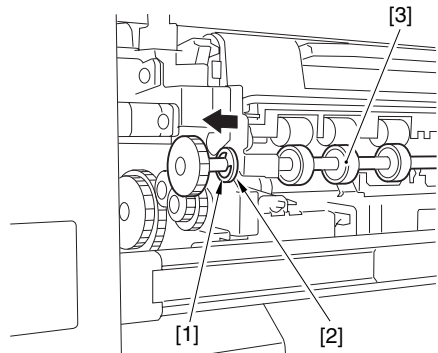

F02-709-25

- 5) Remove the E-ring [1], one-way gear [2], and bearing [3] at the rear of the external roller shaft; then, remove the 2 E-rings [4] and the 2 rollers [5] of each roller.



Take care not to lose the parallel pin used in each roller.

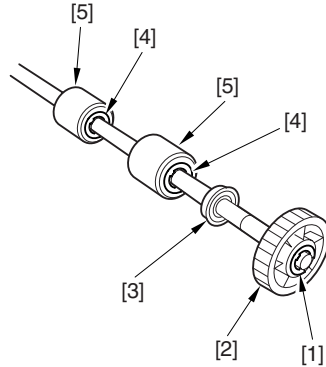

F02-709-26

b. Removing the Internal Delivery Roller

- 1) Remove the fixing assembly.
- 2) Remove the internal delivery roller [1], bearing [2], 3 E-rings [3], and bushing holder [4]; then, detach the drive gear [5].

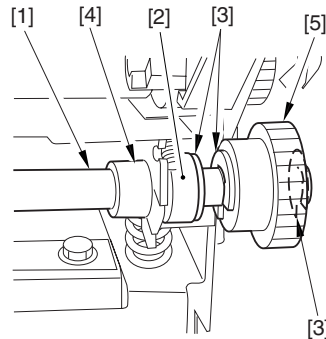

F02-709-27

- 3) Remove the E-ring [1] and the bushing [2] at the rear of the shaft; then, detach the internal delivery roller [3].

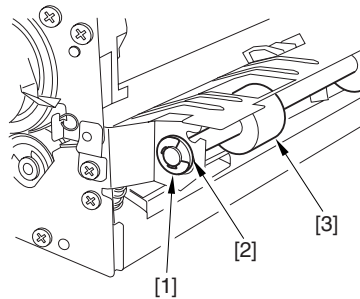

F02-709-28

c. Removing the Delivery Speed Switching Clutch

- 1) Slide out the fixing/feeder unit.
- 2) Remove the fixing motor.
- 3) Remove the 3 screws [1], and detach the fixing front support base [2].

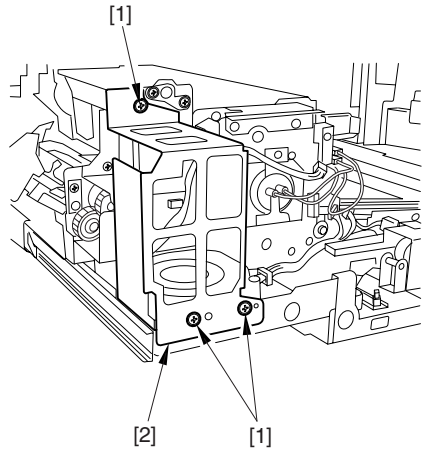

F02-709-29

- 4) Disconnect the 2 connectors [1], and remove the 2 screws [2]; then, detach the delivery speed switching clutch [3].



When detaching the delivery speed switching clutch, take care not to lose the bearings on both ends of the clutch shaft and the washer at the rear.

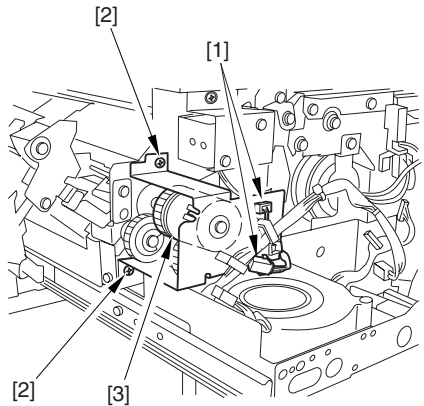

F02-709-30

7.9.4 Paper Sensors

a. Removing the Claw Jam Sensor

- 1) Remove the fixing assembly.
- 2) Remove the 2 screws, and detach the lower separation claw assembly.
- 3) Detach the claw jam sensor [1] from the right side of the lower delivery assembly.

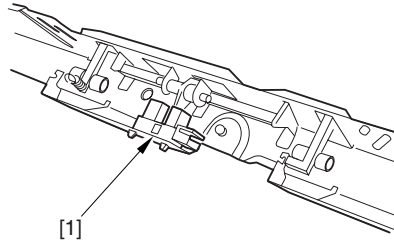

F02-709-31

b. Remove the External Delivery Sensor

- 1) Remove the external delivery roller.
- 2) Remove the 2 screws [1], and disconnect the connector [2]; then, detach the external sensor assembly [3].

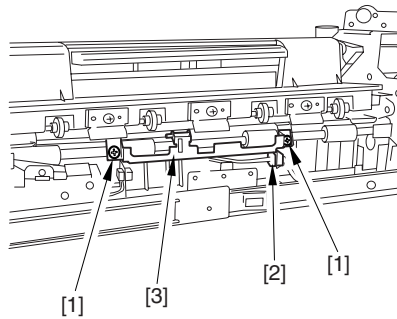

F02-709-32

- 3) Disconnect the connector [1], and detach the external delivery sensor [2].

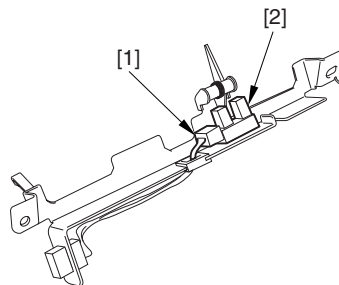

F02-709-33

c. Removing the Internal Delivery Sensor

- 1) Remove the fixing assembly.
- 2) Open the upper delivery assembly, and remove the 2 screws [1]; then, detach the internal delivery sensor assembly [2].

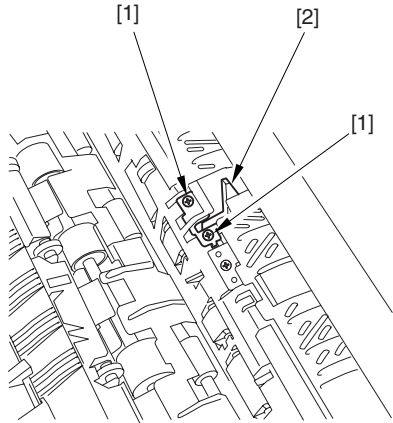

F02-709-34

- 3) Disconnect the connector [1], and detach the internal delivery sensor [2].

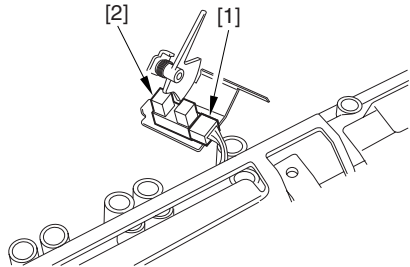

F02-709-35

d. Remove the Fixing/Feeder Unit Outlet Sensor

- 1) Slide out the fixing/feed unit
- 2) Remove the screw [1] from the bottom face of the fixing/feeder unit; then, detach the fixing/feed outlet sensor [2].

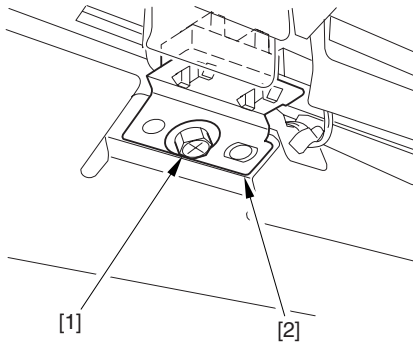

F02-709-36

- 3) Disconnect the connector [1], and detach the fixing/feed outlet sensor [2].

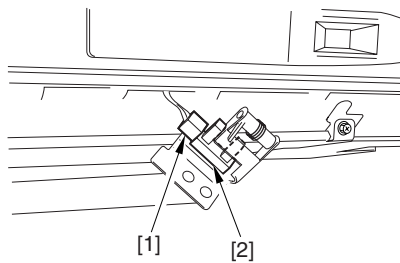

F02-709-37

8 Externals/Auxiliary Controls

8.1 Changes Made to Externals/Auxiliary Controls

Unit/location	Changes from GP605 (IR600)	Purpose of change	Remarks	Reference
Fan	Added a developing fan.	To cool the developing unit.		8.2 Fans
	Added a system fan.	To cool the inside of the system box.		8.2 Fans
	Added a delivery adhesion preventing fan.	To cool the delivery assembly.		8.2 Fans
	Added a scanner motor cooling fan.	To cool the scanner motor.		8.2 Fans
	Added a laser motor cooling fan.	To accommodate the integration of the primary charging assembly and the laser scanner motor cooling fan functions.		8.2 Fans
	Added a duplex/feeding fan.	To cool the duplexing/feeding assembly.		8.2 Fans
	Added a separation heat discharge fan.	To enhance discharge of heat from around the separation assembly and to enhance separation performance.		8.2 Fans
	Eliminated the primary charging assembly fan.	To accommodate the use of the laser motor cooling fan.		
	Eliminated the feeding fan.	To accommodate the use of the separation fan.		
	Eliminated the laser scanner motor cooling fan.	To accommodate the use of the laser motor cooling fan.		
Externals	Changed the design of the system cover (it remains in the body).	To improve the serviceability of the main controller PCB-related work.		
	Added an angular opening for duct suction in the rear upper cover.	To cool the inverter.		
	Added a gasket to the rear upper cover.	To suppress noise.		
	Added a new louver to the left lower cover (upward compatible).	To cool the all-night power supply unit.		
Cassette	Added a side louver to the front cover.	To prevent overheating of the developing assembly, cleaner, and laser scanner.		
	Made to use 2 heat discharge openings in the rear cover.	To prevent overheating.		
	Made to use an upright display for the control panel.	To improve recognition.		
	Changed the exterior appearance of the cassette.	To standardize the design.		

T02-801-01

8.2 Fans

F02-802-01 show the arrangement of fans used in the machine and the direction of air for each; for the name and function of each, see T02-801-01:

The fans added to the machine are as follows:

- [1] Laser motor cooling fan (FM1)
- [13] Developing fan (FM15)
- [14] System fan (FM16)
- [15] Delivery adhesion-preventing fan (FM17)
- [16] Scanner motor fan (FM18)
- [17] Duplex/feeding fan (FM19)
- [18] Separation heat discharge fan (FM20)

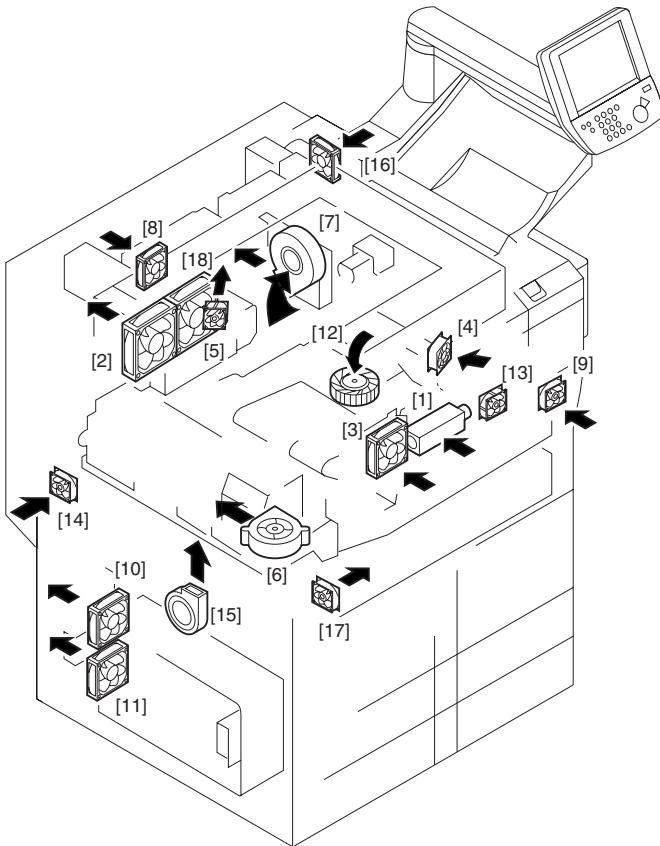

F02-802-01

Ref.	Notation	Name	Function	Error code	Alarm code
[1]	FM1	laser motor cooling fan	cools laser scanner motor, insulates heat for fixing assembly, prevents soiling of wire in primary charging wire	E111	
[2]	FM2	fixing heater discharge fan	discharges heat from around fixing assembly	E805-0001	-
[3]	FM3	laser cooling fan 1	cools laser scanner unit	E121-0001	-
[4]	FM4	stream reading fan	cools copyboard glass in stream reading mode	-	330010
[5]	FM5	laser cooling fan 2	cools laser driver PCB	E121-0002	-
[6]	FM6	curl-reducing fan	cools paper	-	330001
[7]	FM8	drum fan	draws and cools ozone around drum and stray toner	E820	-
[8]	FM9	inverter cooling fan	cools control panel inverter	E251	-
[9]	FM10	pre-transfer charging assembly fan	discharges ozone from around pre-transfer charging assembly	E823	-
[10]	FM11	power supply cooling fan 1	cools DC power supply PCB	E804	-
[11]	FM12	power supply cooling fan 2	cools DC power supply PCB	E804	-
[12]	FM13	separation fan	assists separation of paper from drum	E830	-
[13]	FM15	developing fan	cools developing assembly	-	330006
[14]	FM16	system fan	cools PCBs inside system box	E804-0004	000804-0004
[15]	FM17	delivery adhesion-preventing fan	cools paper upon delivery	-	330007
[16]	FM18	scanner motor cooling fan	cools scanner motor	-	330005
[17]	FM19	duplexing/feeding fan	cools duplex/feeding motor		330009
[18]	FM20	separation heat discharge fan	discharges heat from around separation assembly and to enhance separation performance	E805-0002	

T02-802-01

8.3 Sequence of Fan Operation

The machine's fans may be either ones operating in conjunction with the state of the printer unit or ones operating in conjunction with the state of the scanning lamp, as shown in either F02-803-01 or F02-803-02.

The scanner cooling fan and the power supply fan operate in relation to the states of both printer unit and the scanning lamp; they are, however, controlled to the higher speed.

When a fan error occurs or the door is opened, the state which the fan was in prior to the error will be used.

• Fans Opening in Keeping with the State of the Printer Unit

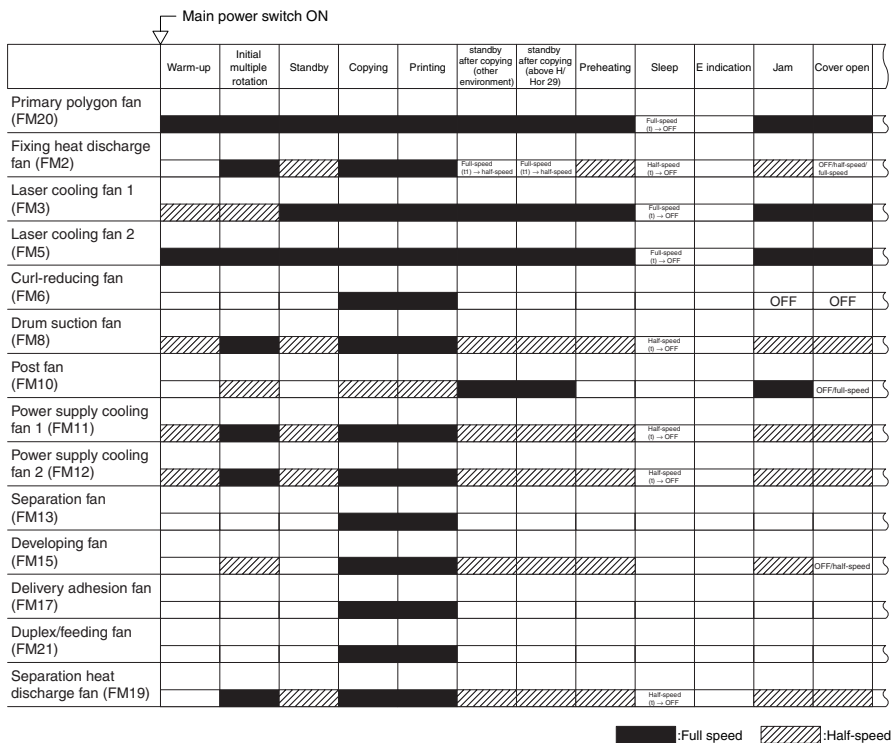

F02-803-01

• Fans Operating in Keeping with the State of the Scanning Lamp

Main power switch ON

Scanning lamp	Lamp ON	Lamp OFF	Standby	Jam	Pre-heat	Scanner ON	Scanner OFF
Optical cooling fan (FM3)	■	▨	▨		▨		
Stream reading fan (FM4)	■	▨	▨		▨		
Inverter cooling fan (FM9)	■	▨	▨		▨		
Power supply cooling fan 1/2 (FM11, FM12)			▨	▨	▨	■	▨

■ : Full speed ▨ : Half speed

F02-803-02

8.4 Disassembly/Assembly

The mechanical characteristics of the machine are as described herein; disassemble/assemble the machine as instructed and with the following in mind:

1.  Before starting any disassembly/assembly work, turn off the main power switch, and disconnect the power plug.
2. Unless otherwise specifically instructed, assemble the machine by reversing the steps used to disassemble it.
3. Identify the screws by type (length, diameter) and location.
4. To protect against static charge, one of the mounting screws of the rear cover comes with a toothed washer. Be sure not to leave out the washer when assembling the machine.
5. To ensure electrical continuity, the mounting screw for the grounding wire and the varistor comes with a washer. Be sure not to leave out the washer when assembling the machine.
6. As a rule, do not operate the machine with any of its parts removed.
7. When sliding out the duplex feeder unit or the fixing assembly, be sure to turn off the front cover switch or the power switch.

8.4.1 External Covers

a. Names of the Part

Those covers that can be detached by mere removal of mounting screws are omitted from the discussions (number of screws indicated).

- [1] Upper front cover (8.4.1.g)
- [2] Copyboard glass
- [3] Left glass retainer (2 screws)
- [4] Left pocket plate (8.4.1)
- [5] Upper rear cover (8.4.1.h)
- [6] Right pocket plate (3 screws)
- [7] Original delivery tray (8.4.2.a)
- [8] Manual feed tray (6.6.1.a)
- [9] Lower vertical path cover
- [10] Toner cartridge cover (2 screws)
- [11] Front cover (8.4.1.b)

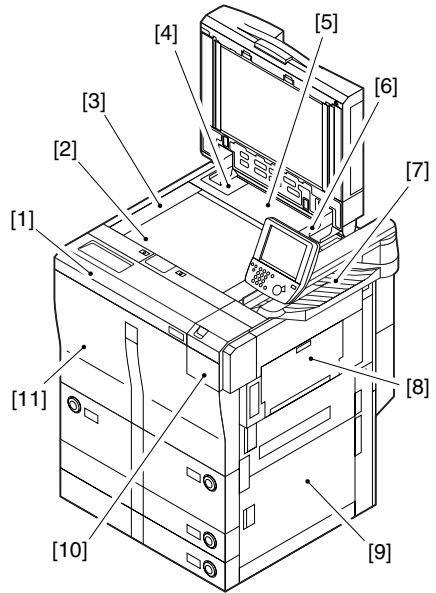

F02-804-01-a

- [12] Right glass retainer (2 screws)
- [13] Scanning lamp cover
- [14] Control panel (8.4.2.a)
- [15] Upper right cover (8.4.2.a)
- [16] Right rear cover (8.4.2.a)
- [17] Waste toner cover (1 screw)
- [18] Right lower cover (2 screws)
- [19] Upper vertical path cover (8.4.1.f)
- [20] Manual feed tray unit (6.6.1.a)
- [21] Face plate cover

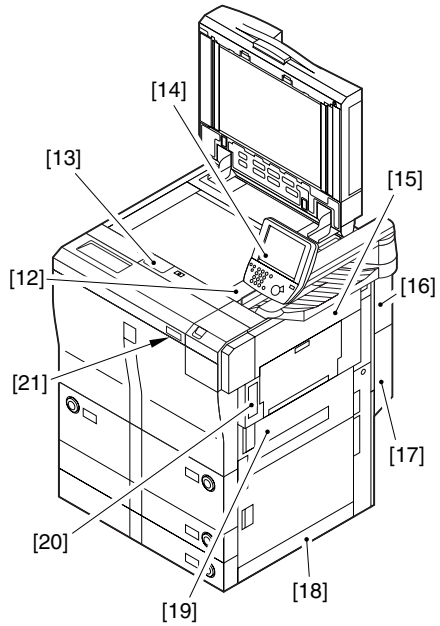

F02-804-01-b

- [22] Control panel unit (8.4.2.a)
- [23] Upper front cover unit (8.4.1.g)
- [24] Upper left cover (3 screws)
- [25] Left upper cover (9 screws; after removing left lower cover)
- [26] Left lower cover (4 screws)
- [27] System connector cover (2 screws)
- [28] Rear cover (8.4.1.e)
- [29] Rear upper cover (2 screws)

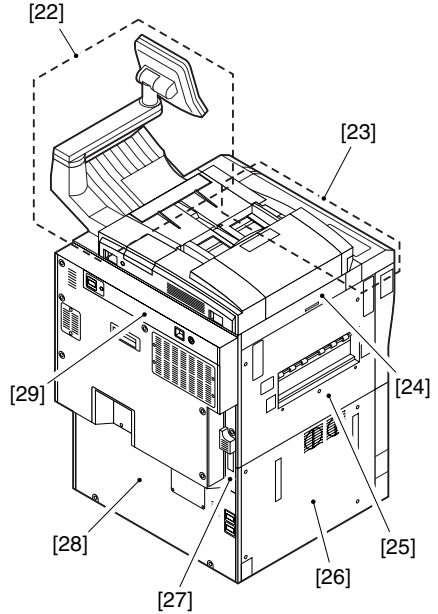

F02-804-02-a

- [30] Inside upper cover (8.4.1.c)
- [31] Primary assembly cover (1 screw)
- [32] Process unit cover
- [33] Compartment cover
- [34] Pre-transfer charging assembly cover (1 screw)
- [35] Transfer/saparation charging assembly cover (1 screw)
- [36] Inside right lower cover (2 screws; 1 screw used in common with front cover tape)
- [37] Duplex unit cover (4 screws, 3 knobs)
- [38] Fixing/feeder unit cover (6.6.6.a)

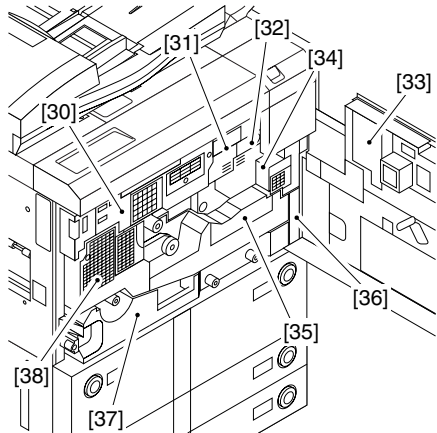

F02-804-02-b

- [39] ADF
- [40] Drum protective sheet (after removing waste toner cover)
- [41] Right deck
- [42] Cassette 4
- [43] Cassette 3
- [44] Left deck

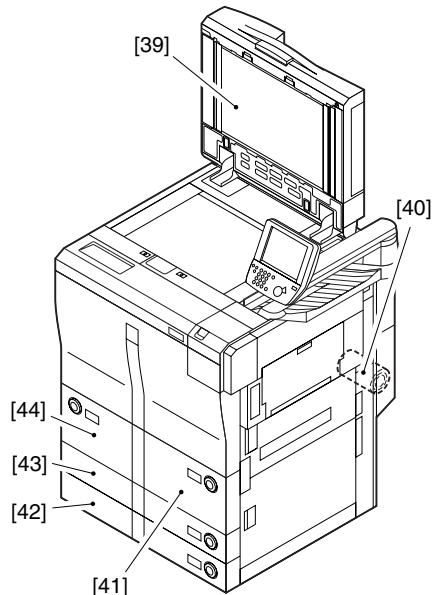

F02-804-02-c

Remove the covers as necessary when cleaning, checking, or repairing the inside of the machine.

b. Removing the Front Cover

- 1) Open the toner cartridge cover [1].
- 2) Open the front cover, and remove the mounting screw [3] for the cover type [2].
- 3) Push up the hinge pin [4] found on the front cover, and turn it to the front 90° to pull it off downward.
- 4) Pull off the front cover at an angle.

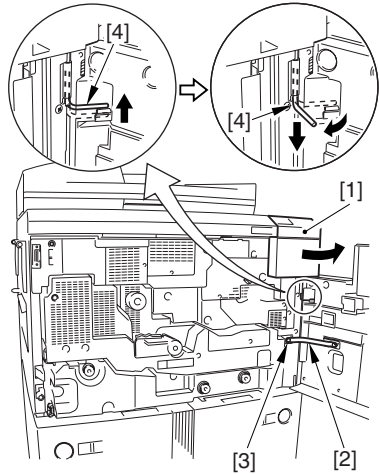

F02-804-03

c. Removing the Inside Upper Cover

- 1) The toner cartridge cover.
- 2) Open the front cover.
- 3) Remove the mounting screw [1], and detach the primary charging assembly cover [2].
- 4) Shift down the fixing/feeding lever [3], and slide out the fixing/feeder unit [4].

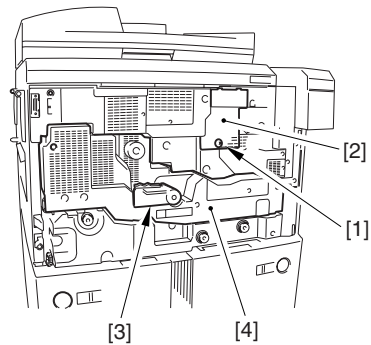

F02-804-04

- 5) Disconnect the 2 connectors [1].
- 6) Remove the 5 mounting screws [2], and detach the inside upper cover [3].

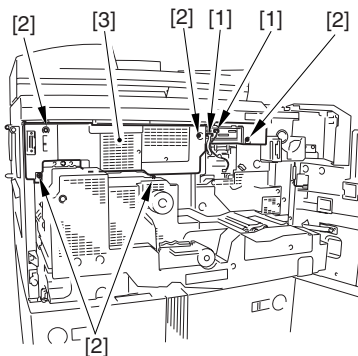

F02-804-05

d. Removing the Fixing/Feeder Unit Cover

- 1) Open the front cover, and shift down the fixing/feeding lever to slide out the fixing/feeding unit.
- 2) Remove the mounting screw [2] of the releasing lever [1]; then, pushing the releasing lever link [3] found at the rear of the fixing/feeder unit, remove the releasing lever while keeping it shifted up.

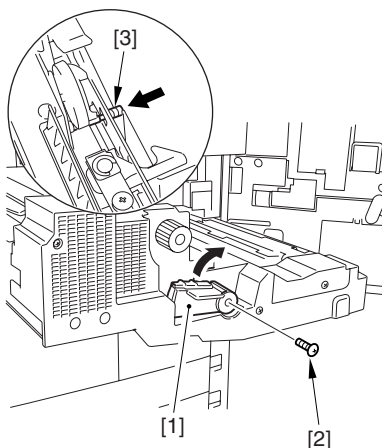

F02-804-06

- 3) Remove the mounting screw [1], and detach the fixing knob [2].
- 4) Remove the mounting screw [3], and detach the transfer separation charging assembly cover [4].
- 5) Remove the 2 mounting screws [5], and detach the fixing/feeder unit cover [6].

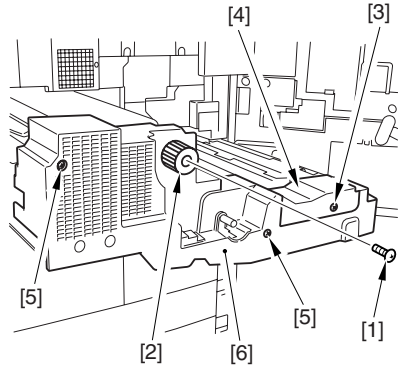

F02-804-07

e. Removing the Rear Cover

- 1) Remove the 11 mounting screws [1], and detach the rear cover [2].

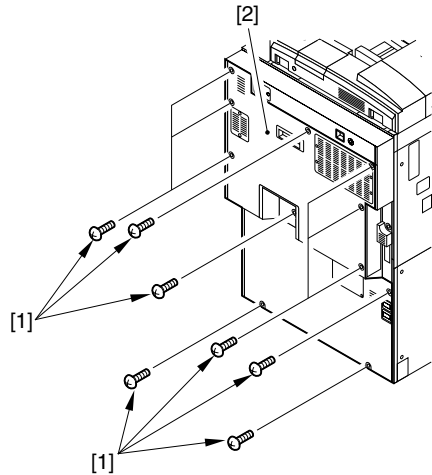

F02-804-08

f. Removing the Upper Vertical Path Cover

- 1) Open the Manual feed tray unit.
- 2) Open the upper vertical path cover [2].
- 3) Holding the Manual feed tray unit [1] slightly up, pull out the upper vertical path cover [2] upward.

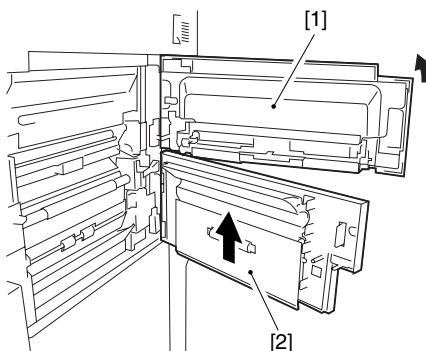

F02-804-09

g. Removing the Upper Front Cover Unit

- 1) Remove the inside upper cover.
- 2) Remove the flat-headed screw [1] (1 pc. each), and detach the 2 magnet catches [2].
- 3) Remove the face plate [3], and remove the 3 screws [4]; then, detach the upper front cover unit [5].

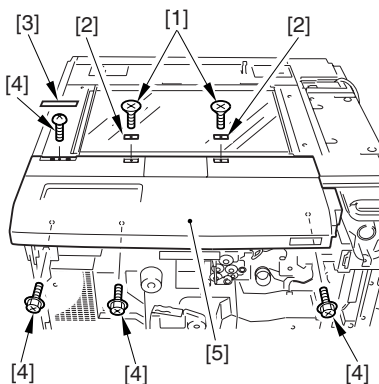

F02-804-10



If the card reader is mounted, be sure to disconnect the connector [1].

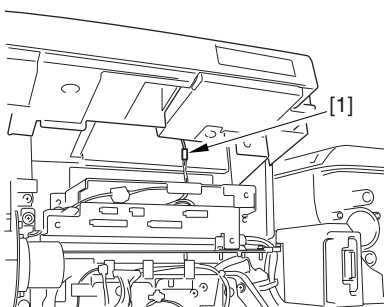

F02-804-11

h. Removing the Upper Rear Cover

- 1) Remove the ADF.
- 2) Remove the 3 screws [1], and detach the right pocket plate [2].
- 3) Remove the 3 screws [3], and detach the left pocket plate [4].



Mark the position of the screw [3] so that the left pocket plate [4] may be mounted back to its original position.

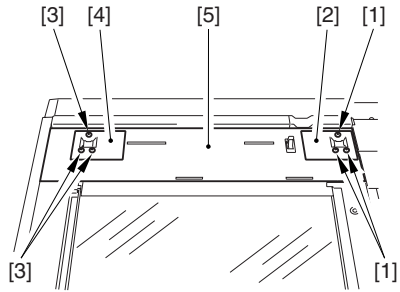

F02-804-12

- 4) Remove the upper rear cover [5].

8.4.2 Control Panel

a. Removing the Control Panel Unit

- 1) Disconnect the connector [1].

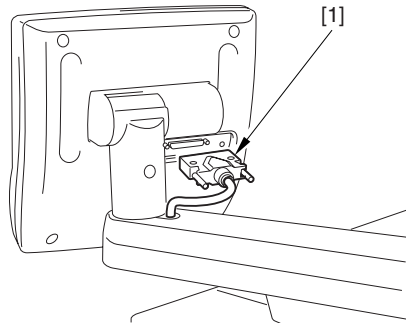

F02-804-13a



If for a 230V model, detach the ferrite core [2].

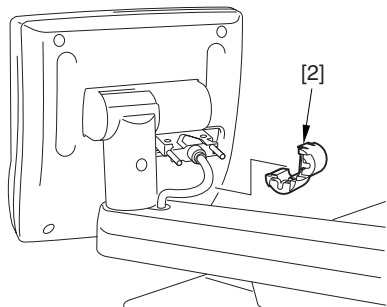

F02-804-13b

- 2) Remove the binding screw [1], and detach the lower arm cover [2].
- 3) Remove the 2 binding screws [4] used to keep the upper arm cover [3] in place.

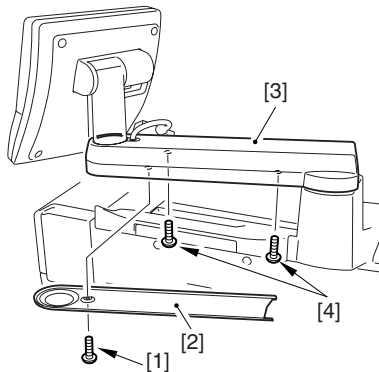

F02-804-14

- 4) Remove the binding screw [1], and detach the rear support cover [2].
- 5) Remove the double washer screw [3] and the flat-headed screw [4], and detach the control panel [5].

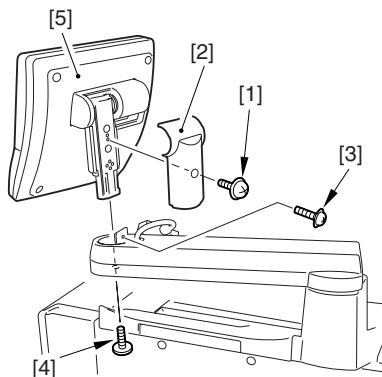

F02-804-15

- 6) While paying attention to the claw [2], detach the upper arm cover [1].
- 7) Remove the harness clip [3].



The harness clip will divide into two during the work. Continue the work, as it will not adversely affect any function.

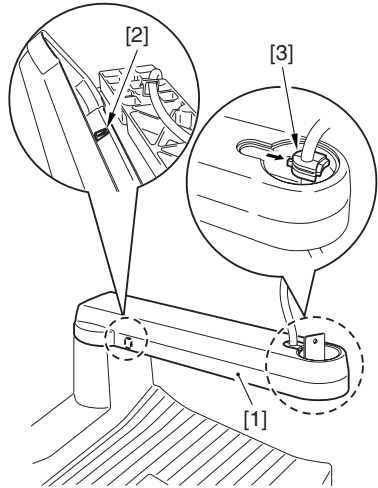

F02-804-16

- 8) Free the control panel harness [2] from the 2 wire saddles [1].
- 9) Remove the 4 binding screws [3] and the positioning binding screw [4]; then, while paying attention to the claw [6], detach the upper arm [5].
At this time, be sure to take a note of the position of the binding screw [4].



When mounting, be sure to match the marking [7] of the control panel harness against the wire saddle at the rear.

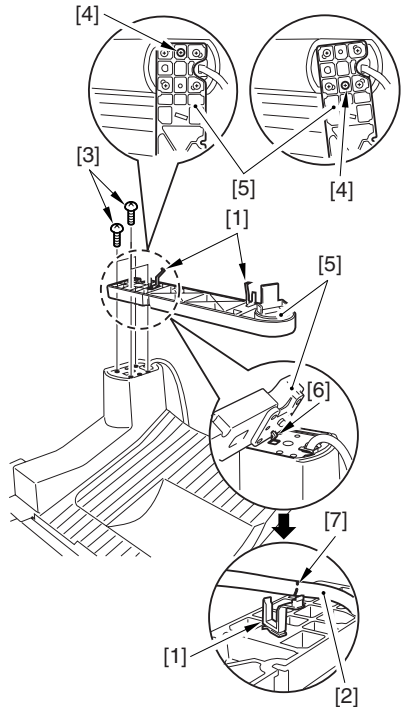

F02-804-17

- 10) Remove the 2 RS tightening screws [1], and detach the original delivery tray [2].

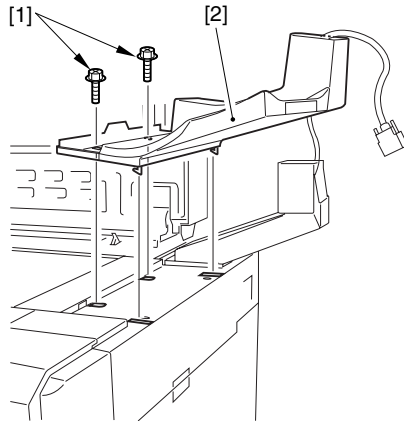

F02-804-18

- 11) Open the toner cartridge [1], and remove the 3 RS tightening screws [2]; then, while paying attention to the claw [4], detach the upper right cover [3].

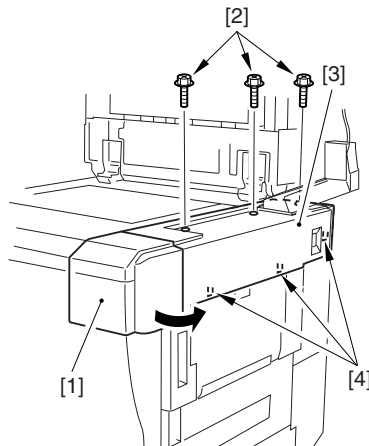

F02-804-19

- 12) Remove the 6 RS tightening screws [1]; then, while paying attention to the claw [3], detach the lower arm [2].

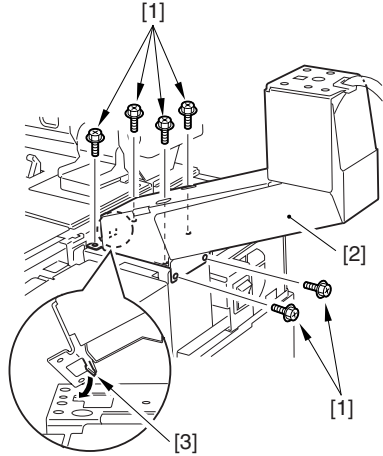

F02-804-20

- 13) Open the 2 edge saddles [1], and pull out the control panel harness [3] from the lower arm [2].

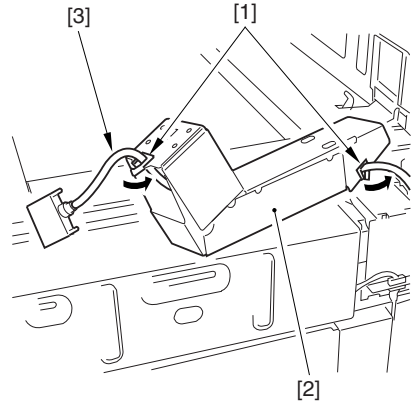

F02-804-21

b. Removing the Control Panel Support Unit

- 1) Remove the 2 screws [1], and detach the support front cover [2].
- 2) Remove the 5 screws [3], and detach the control panel rear cover [4].

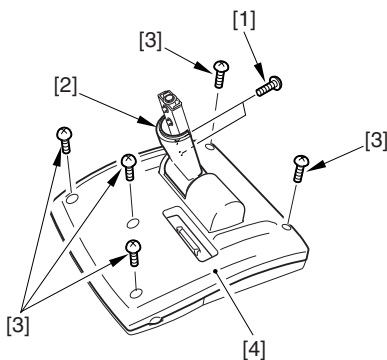

F02-804-22

- 3) Remove the 2 screws [1], 2 connector fixing screws [2], and 2 spring washers [3]; then, detach the connector cover [4].
- 4) Remove the 9 screws [5], and detach the control panel support unit [6].

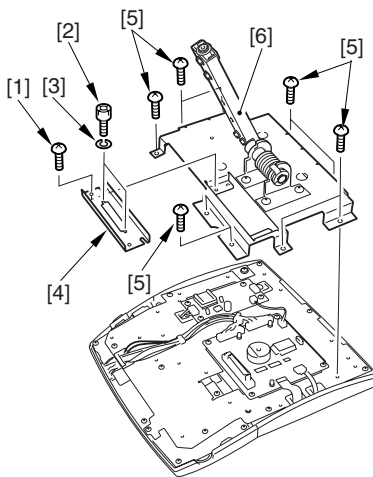

F02-804-23

c. Removing the Control Panel Controller (CPU) PCB

- 1) Remove the control panel support unit.
- 2) Disconnect the 3 connectors [1], and detach the 2 flat cables [2].
- 3) Remove the 4 screws [3], and detach the control panel controller (CPU) PCB [4].

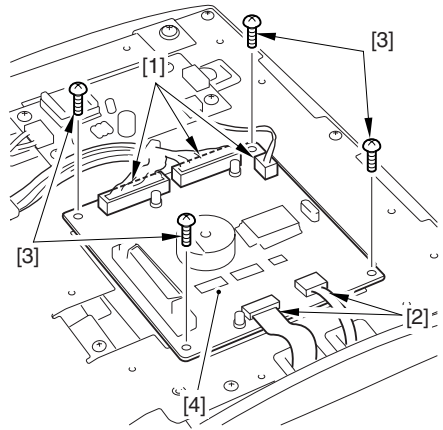

F02-804-24

d. Removing the Control Panel Inverter PCB

- 1) Remove the control panel support unit.
- 2) Disconnect the 3 connectors [1].
- 3) Remove the 4 screws [2], and detach the control panel inverter PCB [3].

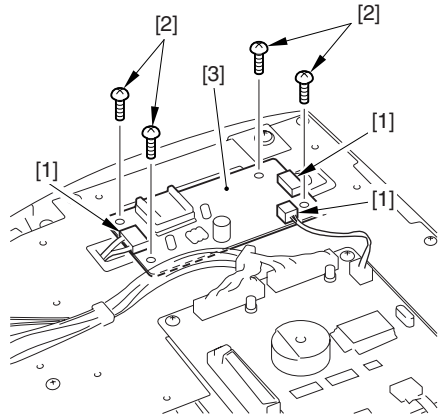

F02-804-25

e. Removing the LCD Panel

- 1) Remove the control panel controller (CPU) PCB.
- 2) Remove the control panel inverter PCB.
- 3) Remove the W washer screw [1], and detach the grounding sheet [2].
- 4) Remove the screw [3], and detach the LCD panel unit [4].

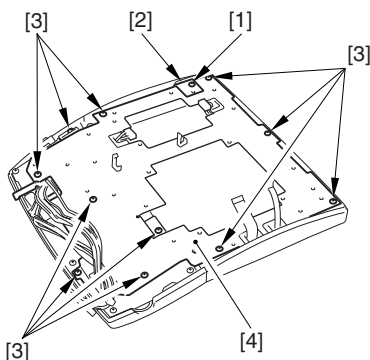

F02-804-26

- 5) Remove the 4 screws [1], and detach the LCD panel [2].

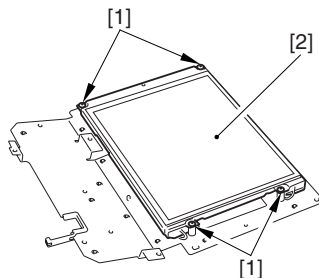

F02-804-27

f. Removing the Control Panel PCB

- 1) Remove the LCD panel unit.
- 2) Remove the harness sheet [1].
- 3) Remove the 10 screws [2], and detach the control panel PCB [3].

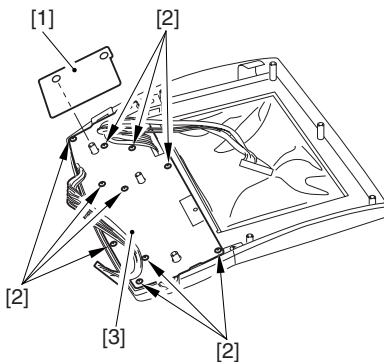

F02-804-28

8.4.3 Fans

a. Removing the Laser Motor Cooling Fan (FM1)

- 1) Remove the inside upper cover. (See 8.4.1.c.)
- 2) Disconnect the connector [1], and remove the harness lock [2] from the plate.
- 3) Remove the 4 screws [3], and detach the laser motor cooling fan [4].

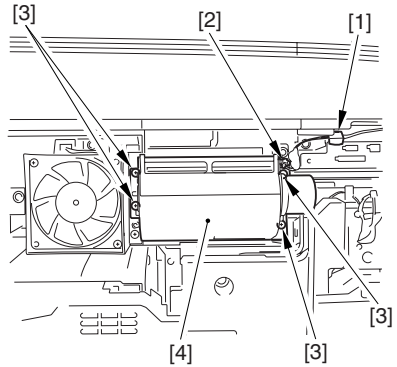

F02-804-29

b. Removing the Fixing Heat Discharge Fan (FM2)

- 1) Remove the rear cover. (See 8.4.1.e.)
- 2) Remove the 2 screws [1], and disconnect the connector [2]; then, detach the fixing heat discharge fan [3].



When mounting the fan, be sure that the direction of air current is as indicated by the arrow.

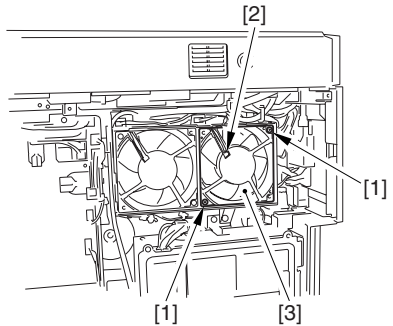

F02-804-30

c. Removing the Laser Cooling Fan 1 (FM3)

- 1) Remove the inside upper cover. (See 8.4.1.c.)
- 2) Disconnect the connector, and remove the 2 screws [2]; then, detach the laser cooling fan 1 [3].



When mounting the fan, be sure that the direction of air current is as indicated by the arrow.

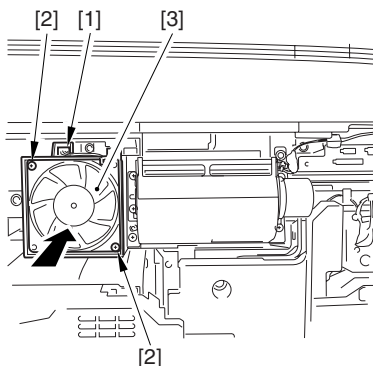

F02-804-31

d. Removing the Stream Reading Fan (FM4)

- 1) Remove the upper front cover unit. (See 8.4.1.g.)
- 2) Remove the 2 screws [1], and detach the stream read fan dust [2].



When mounting the fan, be sure that the direction of air current is as indicated by the arrow.

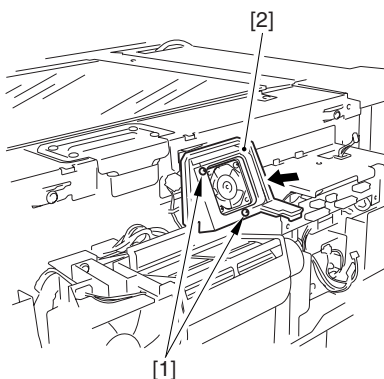

F02-804-32

- 3) Disconnect the connector [1], and remove the 2 screws [2]; then, detach the stream read fan unit [3].

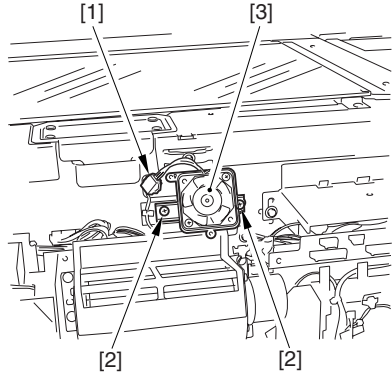

F02-804-33

- 4) Remove the 2 screws [1], and detach the stream read fan [2].

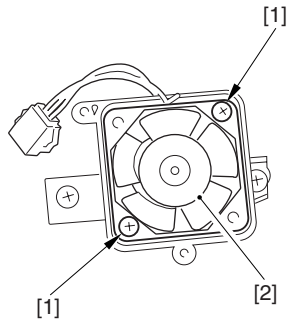

F02-804-34

e. Removing the Laser Cooling Fan 2 (FM5)

- 1) Remove the reader controller PCB. (See 2.9.3.e.)
- 2) Remove the 2 screws [1], and disconnect the connector; then, detach the laser driver cooling fan [3] together with the mounting base.

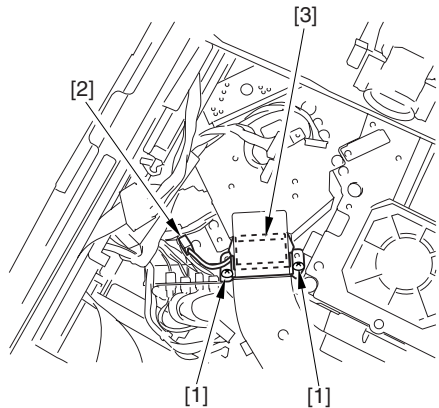

F02-804-35

- 3) Remove the 2 screws [1], and detach the laser driver cooling fan [2].



When mounting the fan, be sure that the direction of air current is as indicated by the arrow.

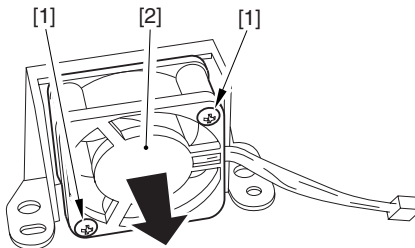

F02-804-36

f. Removing the Curl-Reducing Fan (FM6)

- 1) Remove the fixing/feeding unit cover. (See 8.4.1.d.)
- 2) Disconnect the 4 connectors [1], and remove other 4 screws [2]; then, detach the fixing motor base [3].

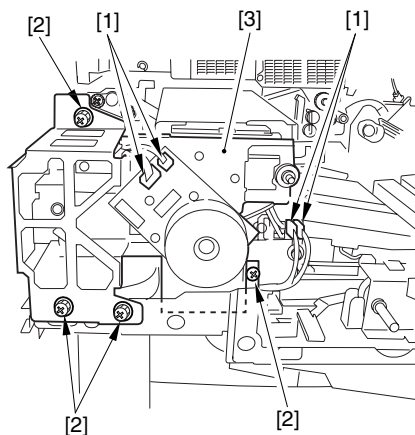

F02-804-37

- 3) Remove the 2 screws [1], and disconnect the 2 connectors [2]; then, detach the delivery speed switching clutch [3].



When removing the delivery speed switching clutch, take care not to lose the bearings and the washers (rear only) on both ends of the clutch shaft.

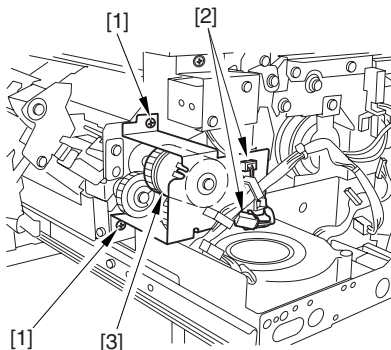

F02-804-38

- 4) Disconnect the connector [1], and remove the 2 screws [2]; then, detach the curl-reducing fan [3].

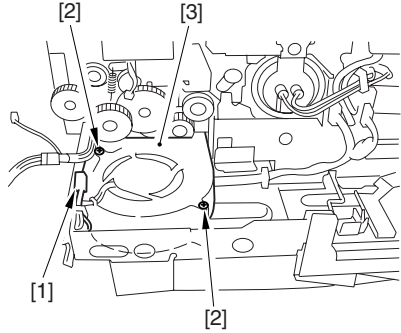

F02-804-39

g. Removing the Drum Fan (FM8)

- 1) Remove the HV-DC PCB. (See 8.4.7.c.)
- 2) Remove the 2 screws [1], and disconnect that connector [2]; then, detach the drum fan unit [3].

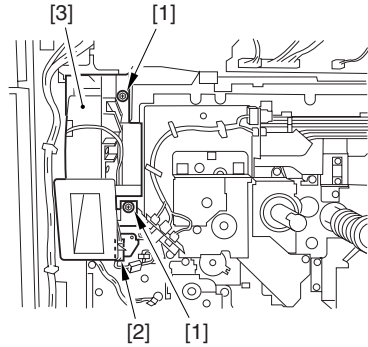

F02-804-40

- 3) Disconnect the connector [1], and remove the 3 screws [2]; then, detach the drum fan [3].

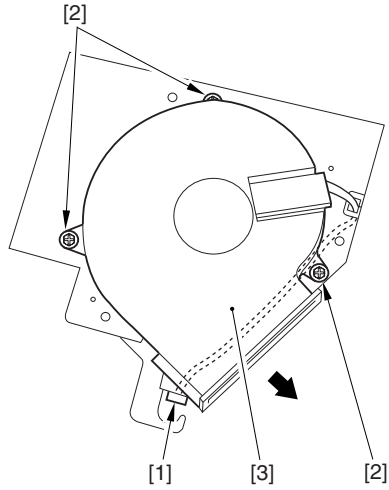

F02-804-41

h. Removing the Inverter Cooling Fan (FM9)

- 1) Remove the rear cover. (See 8.4.1.e.)
- 2) Remove the rear upper cover. (2 screws)
- 3) Remove the screw [1], and detach the inverter cooling fan duct [2].

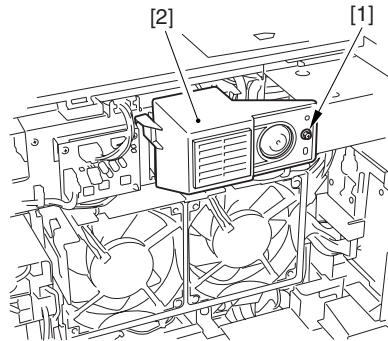

F02-804-42

- 4) Remove the 2 screws [1], and slide out the inverter fan [2].



When mounting the fan, be sure that the direction of air current is as indicated by the arrow.

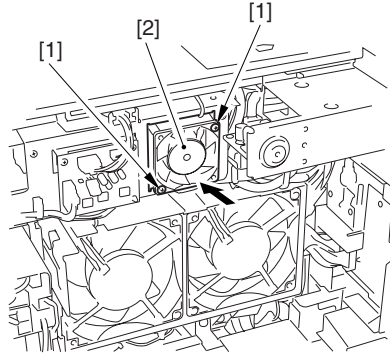

F02-804-43

- 5) Disconnect the connector [1], and detach the inverter cooling fan [2].

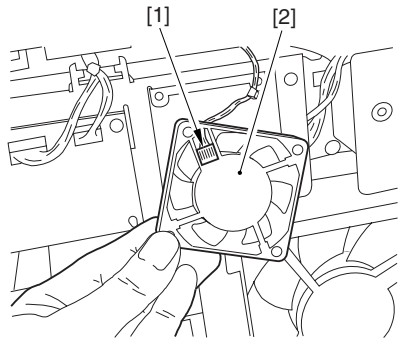

F02-804-44

i. Removing the Pre-Transfer Charging Assembly Fan (FM10)

- 1) Remove the process unit cover. (4 screws)
- 2) Remove the 2 screws [1], and disconnect the 2 connectors [2]; then, detach the fan motor [3].

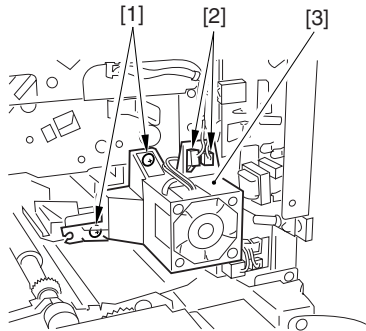

F02-804-45

- 3) Disconnect the connector [1], and remove the 2 screws [2]; then, detach the pre-transfer charging assembly fan [3].



When mounting the fan, be sure that the direction of air current is as indicated by the arrow.

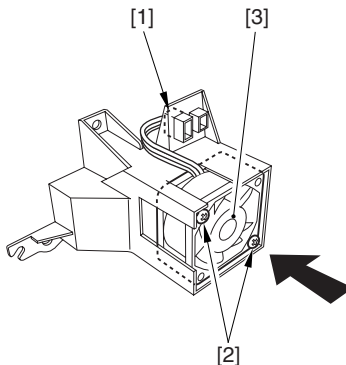

F02-804-46

j. Removing the Power Supply Cooling Fan 1 (FM11)

- 1) Remove the left lower cover. (4 screw)
- 2) Remove the power supply unit. (See 8.4.7.a.)
- 3) Remove the 3 screws [1], and detach the fan mounting base [2].

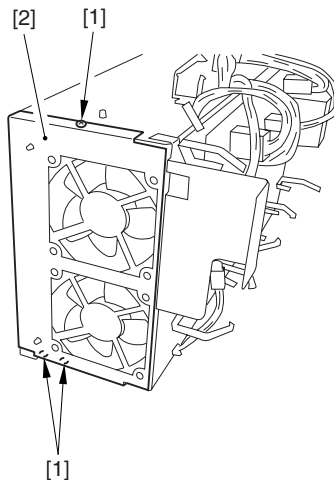

F02-804-47

- 4) Remove the 2 screws [1], and disconnect the connector [2]; then, detach the power supply cooling fan [3].



When mounting the fan, be sure that the direction of air current is as indicated by the arrow.

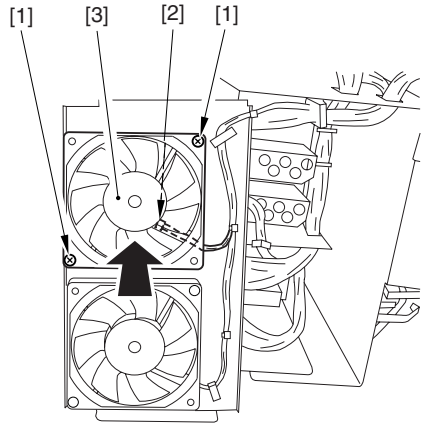

F02-804-48

k. Removing the Power Supply Cooling Fan 2 (FM12)

- 1) Remove the fan mounting base.
(8.4.3.j.)
- 2) Remove the 2 screws [1], and disconnect the connector [2]; then, detach the power supply cooling fan 2 [3].



When mounting the fan, be sure that the direction of air current is as indicated by the arrow.

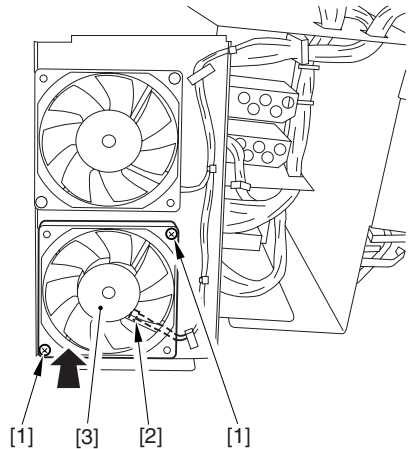

F02-804-49

I. Removing the Separation Fan (FM13)

- 1) Slide out the fixing/feeder unit.
- 2) Remove the 4 screws [1], and detach the fixing/feeding lower cover (1) [2] and the fixing/feeding lower cover (2) [3].

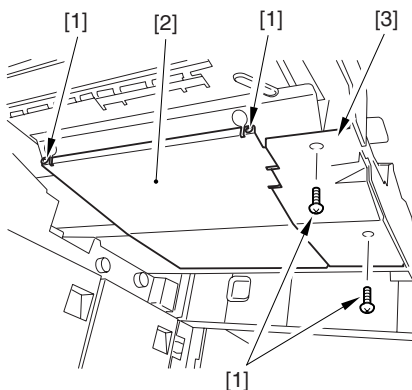

F02-804-50

- 3) Disconnect the connector [1], and remove the heater 3 screws [2]; then, detach the separation fan [3].

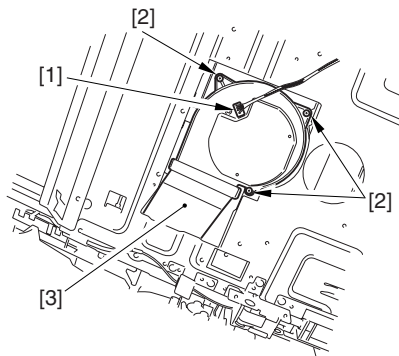

F02-804-51

m. Removing the Developing Fan (FM15)

- 1) Remove the primary charging assembly.
- 2) Disconnect the connector [1], and remove the 2 screws [2]; then, detach the fan unit [3].

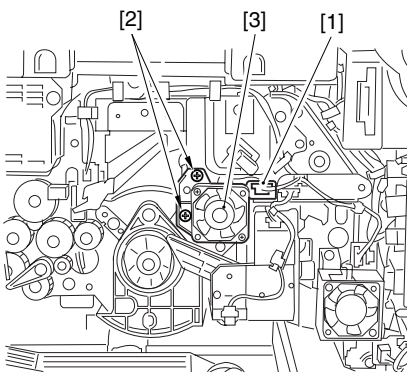

F02-804-52

- 3) Remove the 2 screws [1], and detach the developing assembly fan [2].



When mounting the fan, be sure that the direction of air current is as indicated by the arrow.

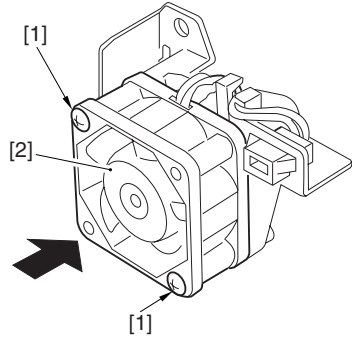

F02-804-53

n. Removing the System Fan (FM16)

- 1) Remove the rear cover. (See 8.4.1.e.)
- 2) Disconnect the connector [1].
- 3) Remove the 2 screws [2], and detach the system connector cover [3].

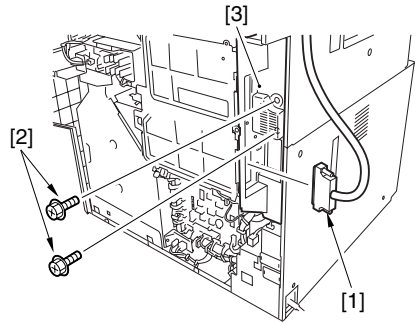

F02-804-54

- 4) Remove the main controller box cover.
- 5) Disconnect the connector [1], and remove the 2 screws [2]; then, detach the system fan [3].



When mounting the fan, be sure that the direction of air current is as indicated by the arrow.

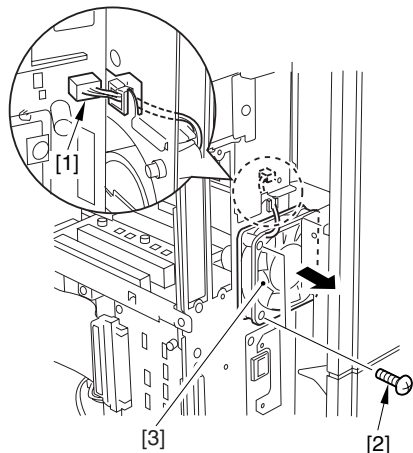

F02-804-55

p. Removing the Delivery Anti-Adhesion Fan (FM17)

- 1) Remove the left lower cover. (4 screws)
- 2) Disconnect the connector [1], and remove the 2 screws [2]; then, detach the fan unit [3].

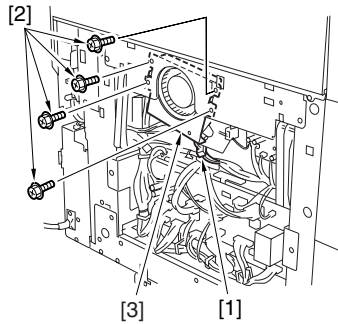

F02-804-56

- 3) Remove the 2 screws [1], and detach the fan [2].

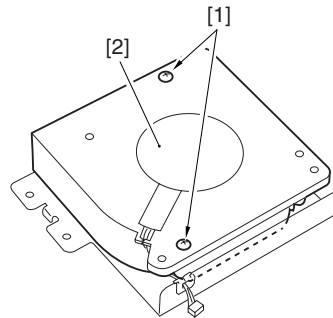

F02-804-57

q. Removing the Scanner Motor Cooling Fan (FM18)

- 1) Remove the rear cover. (See 8.4.1.e.)
- 2) Disconnect the connector [1] on the machine side.
- 3) Remove the 2 screws [2], and detach the scanner motor cooling fan unit [3].

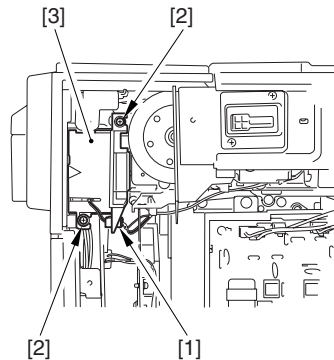

F02-804-58

- 4) Disconnect the connector [1], and remove the 2 screws [2]; then, detach the scanner motor cooling fan [3].



When mounting the fan, be sure that the direction of air is as indicated by the arrow.

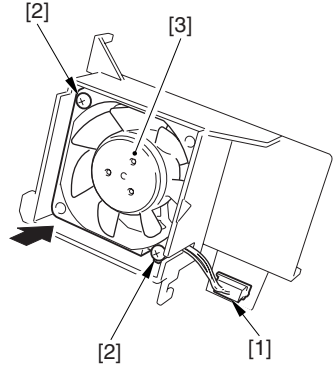

F02-804-59

r. Removing the Duplex Feed Fan (FM19)

- 1) Remove the duplex unit cover. (4 screws, 3 knobs)
- 2) Disconnect the connector [1], and remove the 3 screws [2]; then, detach the duplex feed fan unit [3].
At this time, keep in mind that the shift assembly [4] will also come off.

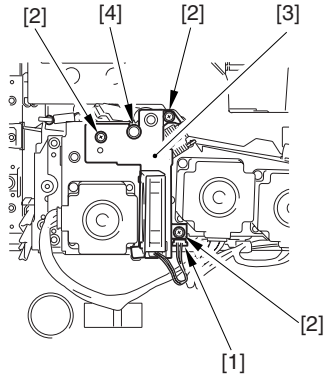

F02-804-60

- 3) Remove the 2 screws [1], and detach the duplex feed fan [2].



When mounting the fan, be sure that the direction of air current is as indicated by the arrow.

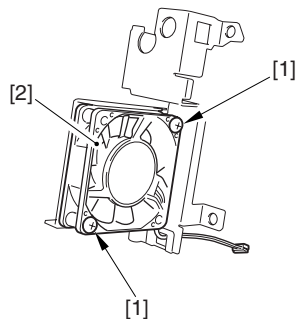

F02-804-61

s. Removing the Separation Heat Discharge Fan (FM20)

- 1) Remove the rear cover. (See 8.4.1.e.)
- 2) Disconnect the connector, and remove the 2 screws [2]; then, detach the separation heat discharge fan [3].

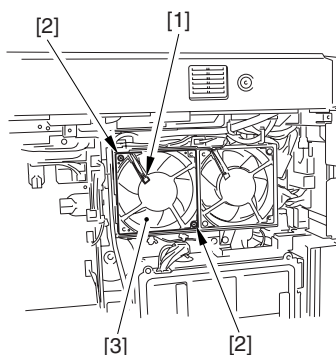

F02-804-62

8.4.4 Drive Assembly

a. Removing the Drive Assembly

- 1) Remove the HV-DC PCB. (See 8.4.7.c.)
- 2) Remove the 2 screws [1], and detach the flywheel [2].

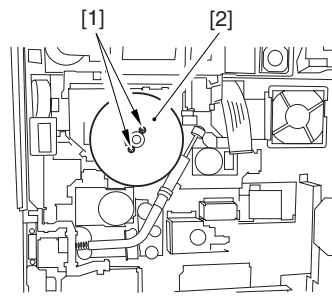

F02-804-63

- 3) Loosen the 2 screws [1] (w/ hex hole), and remove the binding screw [2] (w/ spring); then, detach the gear [3] of the drum shaft.



When removing the screw from the drum shaft gear, be sure to pay attention to the direction of gear rotation, i.e., turn it counterclockwise.

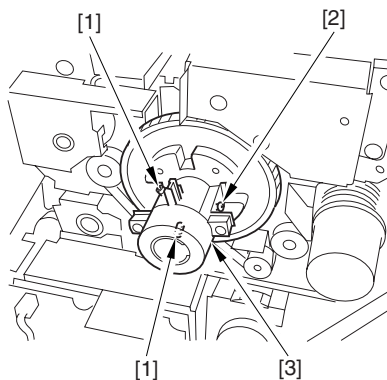

F02-804-64

- 4) Remove the water toner case; then, remove the 5 screws [1], and disconnect the 4 connectors [2] to detach the waste toner case base [3].

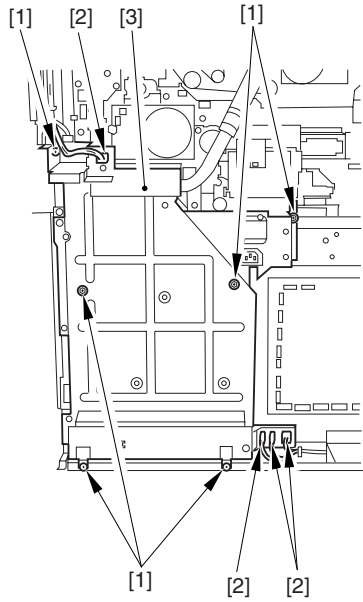

F02-804-65

- 5) Remove the E-ring [2] at the tip of the waste toner pipe [1], and shift the bushing [3] up to remove the 2 screws [4]; then, detach the waste toner pipe [1].

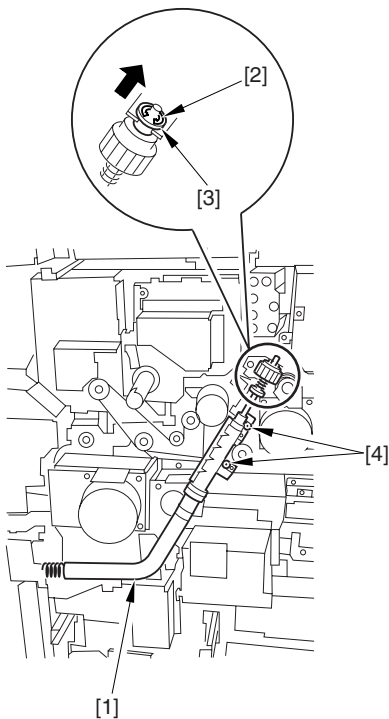

F02-804-66

- 6) Remove the screw [1], and detach the drum cleaner pipe cover [2].

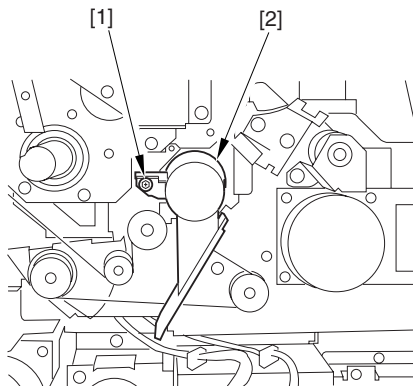

F02-804-67

- 7) Disconnect the 4 connectors [1], and remove the 5 screws [2]; then, detach the drum drive assembly [3].

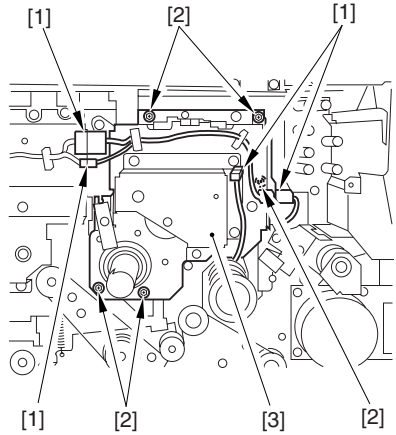

F02-804-68

b. Removing the Cassette Pickup Drive Assembly

- 1) Remove the waste toner case base.
- 2) Remove the cassette pickup assembly (upper, lower).
- 3) Remove the 5 screws [1], and detach the cassette pickup drive assembly [2].

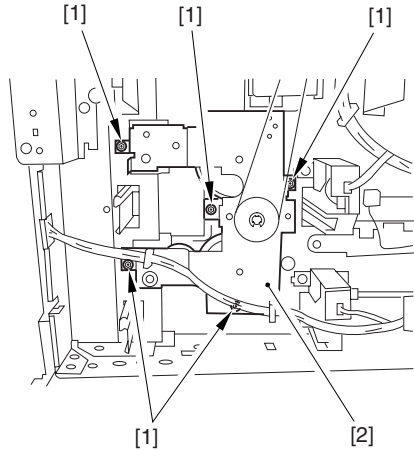

F02-804-69

8.4.5 Switches

a. Removing the Front Cover Switch Assembly

- 1) Remove the upper front cover unit. (See 8.4.1.g.)
- 2) Remove the 3 screws [1], and detach the cover switch assembly [2].

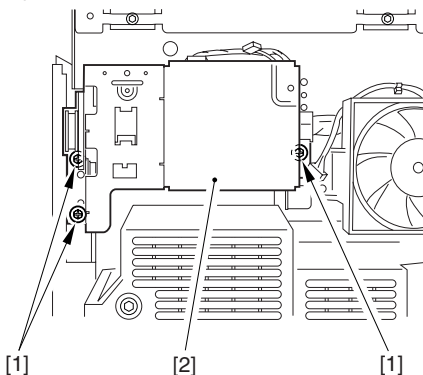

F02-804-70

- 3) Disconnect the 3 connectors [1], and detach the cover switch assembly [2].

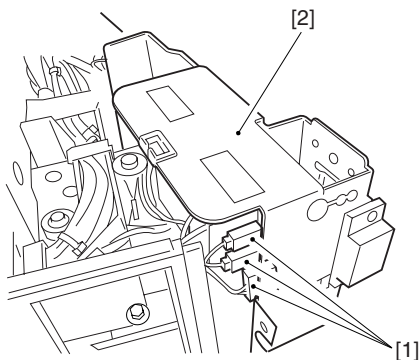

F02-804-71

b. Removing the Manual Feed Tray Switch Assembly

- 1) Remove the process unit cover. (4 screws)
- 2) Remove the 2 screws [1], and disconnect the 2 connectors [2]; then, detach the pre-transfer charging assembly fan [3].

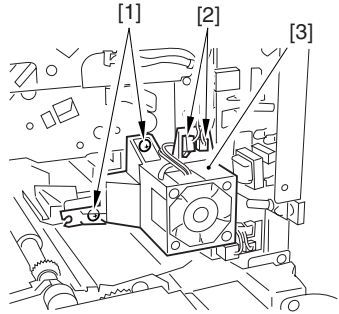

F02-804-72

- 3) Disconnect the 3 connectors [1], and remove the screw [2]; then, detach the potential sensor PCB [3].

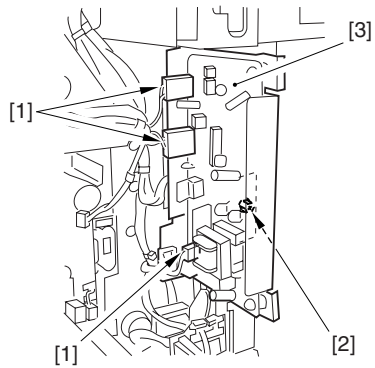

F02-804-73

- 4) Remove the screw [1], and disconnect the 2 connectors [2]; then, detach the manual feed tray switch assembly [3].

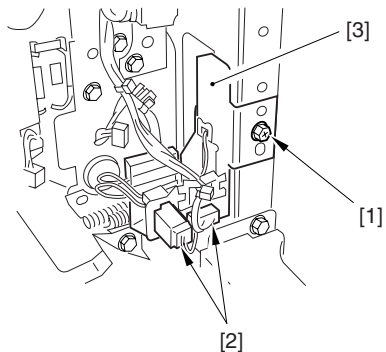

F02-804-74

c. Removing the Drum Heater Switch Assembly

- 1) Remove the rear cover. (See 8.4.1.e.)
- 2) Remove the left lower cover. (4 screws)
- 3) Remove the 3 screws [1], and disconnect the 7 connectors [2]; then, detached power cord base [3]. thereafter, free the fixing claw to detach the drum heat switch [4].

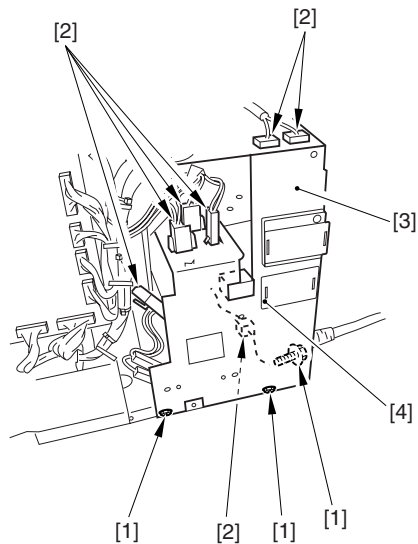

F02-804-75

8.4.6 PCBs

For the following, see their appropriate sections:

- transformer PCB
(2 “Original Exposure System”)
- reader controller PCB
(2 “Original Exposure System”)
- hard disk
(3 “Image Processing System”)
- control panel controller (CPU) PCB
(8.4.2 “Control Panel”)
- control panel inverter PCB
(8.4.2 “Control Panel”)
- control panel PCB
(8.4.2 “Control Panel”)

a. Removing the DC Controller PCB

- 1) Remove the rear cover. (See 8.4.1.e.)
- 2) Disconnect all connectors of the PCB, and remove the 4 screws [1]; then, detach the DC controller PCB [2].

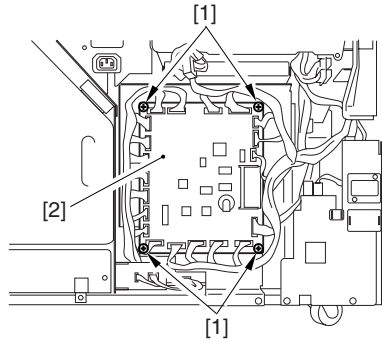

F02-804-76

b. When Replacing the DC Controller PCB

- 1) If possible, print out the user mode/service mode data.
- 2) Replace the DC controller PCB.
- 3) Execute the following in service mode to clear the RAM:
COPIER>FUNCTION>CLEAR>DC-CON.
- 4) Assemble the machine; then, connect the power plug to the power outlet, and turn on the main power switch.
- 5) Enter the following indicated on the service label:
COPIER>ADJUST>LASER (all items)
COPIER>ADJUST>DEVELOP (all items)
COPIER>ADJUST>DENS (all items)
COPIER>ADJUST>BLANK (all items)
COPIER>ADJUST>V-CONT (all items)
COPIER>ADJUST>HV-PRI (all items)
COPIER>ADJUST>HV-TR (all items)
COPIER>ADJUST>HV-SP (all items)
COPIER>ADJUST>FEED-ADJ (all items)
COPIER>ADJUST>CST-ADJ (all items)
COPIER>ADJUST>EXP-LED (all items)
- 6) Execute the following in service mode: COPIER>FUNCTION>MISC-P>CL-ADJ (all items)
COPIER>FUNCTION>SEEN>ADJ (all items)
- 7) Enter the values (4 types) indicated on the label attached to the new DC controller PCB in service mode.

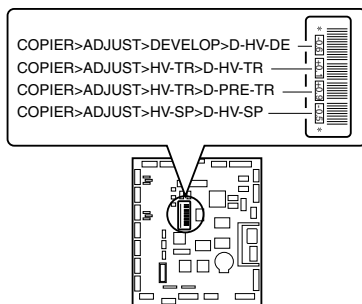

F02-804-77

- 8) Turn off and then on the main power switch.

c. Removing the Differential PCB

- 1) Remove the rear cover. (See 8.4.1.e.)
- 2) Disconnect the reader controller communications cable [1].

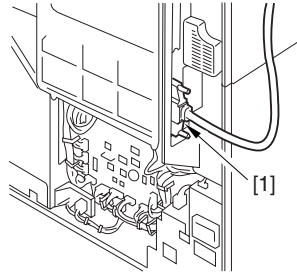

F02-804-78

- 3) Remove the 2 screws [1], and detach the left stop fixing [2]; then, detach the main controller box cover [3].

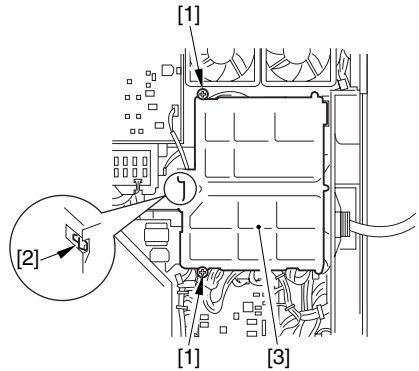

F02-804-79

- 4) Disconnect the main controller communications cable [1] and the connector [2].

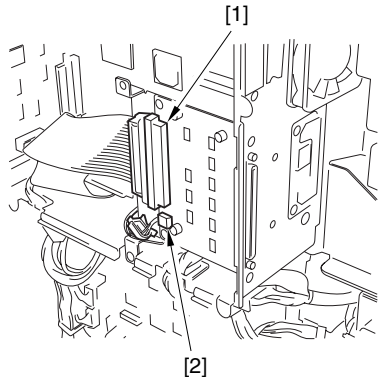

F02-804-80

- 5) Remove the 4 screws [1], and detach the differential PCB [2] together with the mounting base.

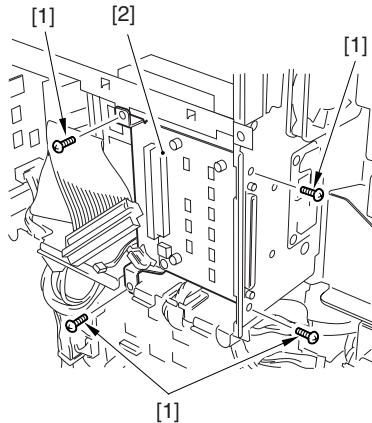

F02-804-81

d. Removing the Pixel/Line Conversion PCB

- 1) Remove the rear cover. (See 8.4.1.)
- 2) Remove the main control box cover.
- 3) Remove the 3 screws [1], and detach the PCB base [2].

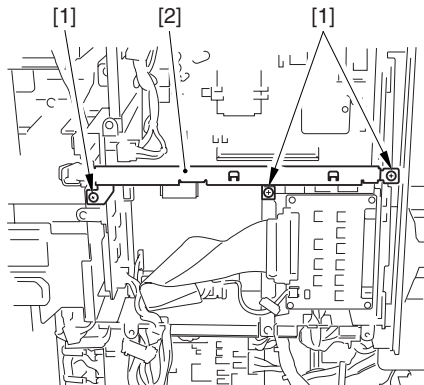

F02-804-82

- 4) Remove the 2 screws [1], and disconnect the 2 connectors [2]; then, detach the pixel/line conversion PCB [3] together with the mounting base.

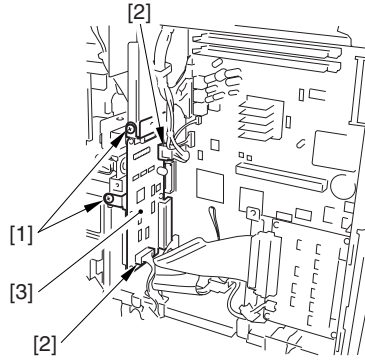

F02-804-83

- 5) Remove the 6 screws [1], and detach the pixel/line conversion PCB [2] from the mounting base.

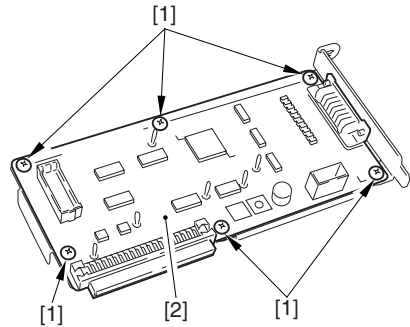

F02-804-84

e. Removing the Main Controller PCB

- 1) Remove the system connector cover.
- 2) Remove the differential PCB (8.4.6.c).
- 3) Remove the pixel/line conversion PCB (8.4.6).
- 4) Disconnect all connectors from the main controller PCB [1].
- 5) Disconnect the connector [2].

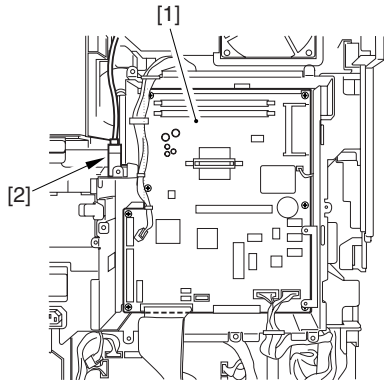

F02-804-85

- 6) Remove the 4 screws [1], and open the main controller box [2].

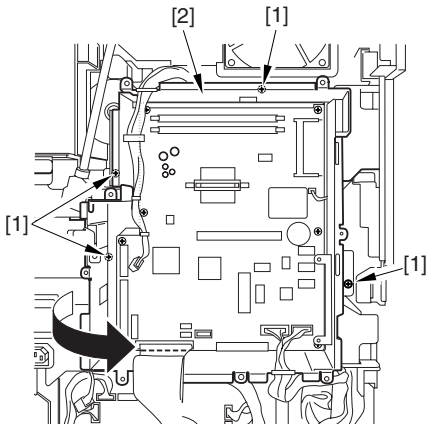

F02-804-86

- 7) Remove the 3 screws [1], and detach the lower cover [2] for the main controller box.

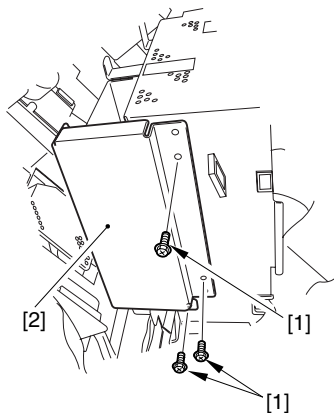

F02-804-87

- 8) Disconnect the cable [1] from the hard disk; then, remove the 8 screws [2], and detach the main controller PCB [3].

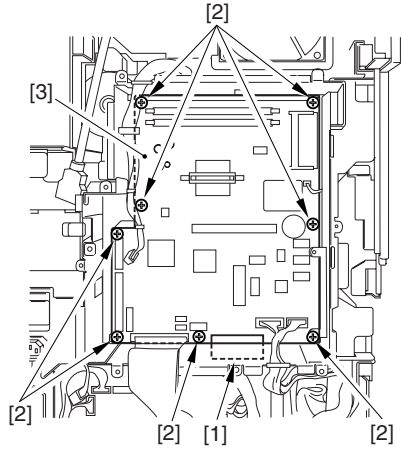

F02-804-88

f. When Replacing the Main Controller PCB

- 1) Replace the main controller PCB.
- 2) Detach the following from the existing PCB, and mount them to the new PCB:
 - SD-RAM [1]
 - BOOT-ROM [2]
 - counter memory PCB [3]

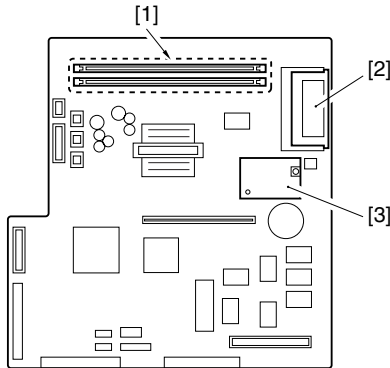

F02-804-89

- 3) Assemble the machine; then, connect the power plug to the power outlet, and turn on the main power switch.

g. Removing the AC Driver PCB

- 1) Detach delivery anti-adhesion fan mounting base. (See 8.4.6.i.)
- 2) Remove the mounting screw [2] of the grounding wire [1].
- 3) Disconnect the 8 connectors [3], and remove the 3 screws [4]; then, detach the AC driver PCB [5].

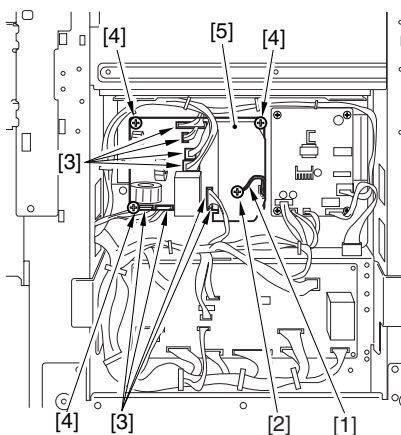

F02-804-90

h. Removing the HV-AC PCB

- 1) Remove the rear cover. (See 8.4.1.e.)
- 2) Disconnect the 2 connectors [1], and remove the 4 screws [2]; then, detach the HV-AC PCB [3].

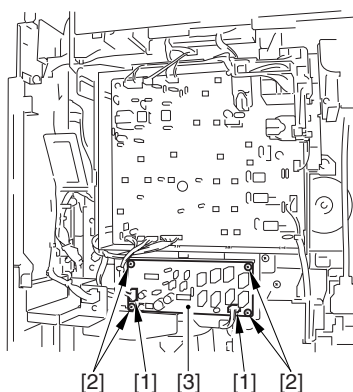

F02-804-91

i. Removing the All Night Power Supply PCB

- 1) Remove the left lower cover (4 screws), and remove the left upper cover (9 screws).
- 2) Disconnect the connector [1], and remove the 6 screws [2]; then, detach the delivery anti-adhesion fan mounting case [3].

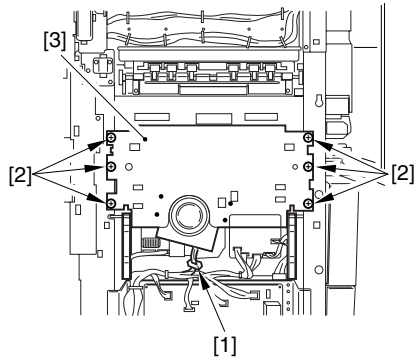

F02-804-92

- 3) Disconnect the 5 connectors [1], and remove the 4 screws [2]; then, detach the all-night power supply PCB [3].

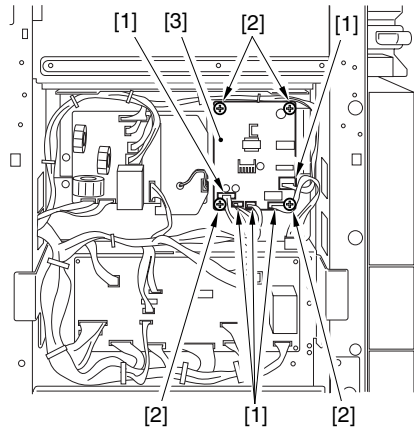

F02-804-93

j. Removing the Bi-centronics PCB

- 1) Remove the rear cover. (See 8.4.1.e.)
- 2) Remove the rear upper cover (2 screws), left lower cover (2 screw), left upper cover (9 screws), and upper left cover (3 screws).
- 3) Disconnect the 3 connectors [1].

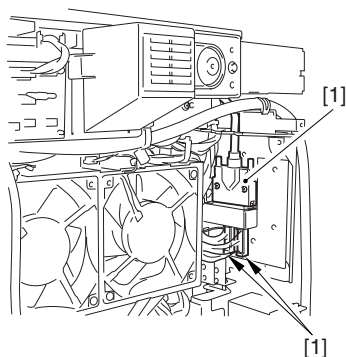

F02-804-94

- 4) Remove the screw [1], and detach the harness fixing plate [2].

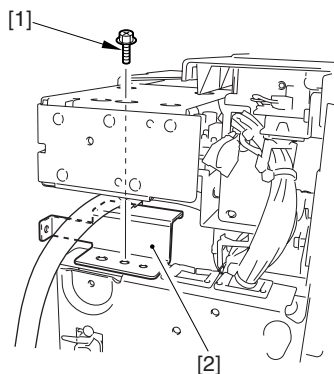

F02-804-95

- 5) Remove the 2 screws [1], and detach the positioning pin [2].
- 6) Remove the 5 screws [3], and detach the Bi-centronics PCB unit [4].

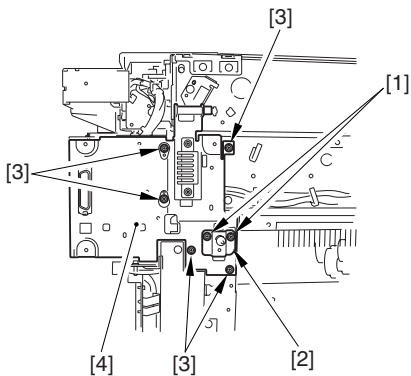

F02-804-96

- 7) Remove the 6 screws [1] and the 2 locking supports [2], and detach the Bi-centronics PCB [3] together with the connector cover.

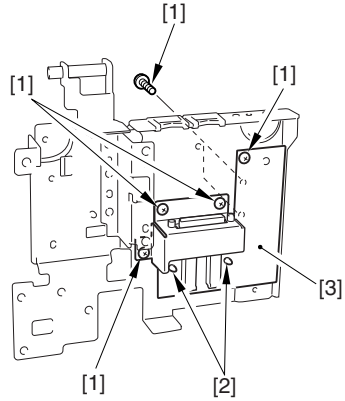

F02-804-97

- 8) Remove the 2 connector fixing screws [1], and detach the connector cover [3] from the Bi-centronics PCB [2].

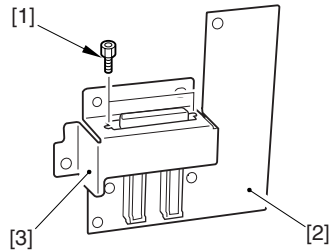

F02-804-98

k. Removing the Relay PCB

- 1) Remove the left lower cover. (4 screws)
- 2) Disconnect the connector from the PCB; then, remove the screw [1], and detach the relay PCB [1] from the four PCB holders [2].

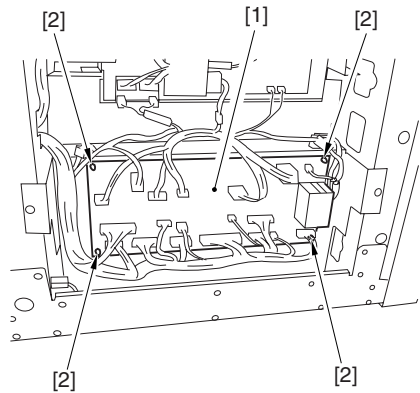

F02-804-99

8.4.7 Others

a. Removing the Power Supply Unit

- 1) Remove the left lower cover. (4 screws)
- 2) Disconnect the 2 connectors [1], and disconnect the connector from the relay PCB [2].

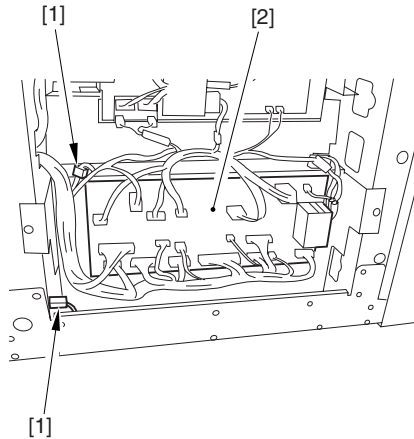

F02-804-100

- 3) Remove the 2 screws [1], and detach the cover plate [2]; them, remove the 2 screws [3], and detach the power supply unit [4].

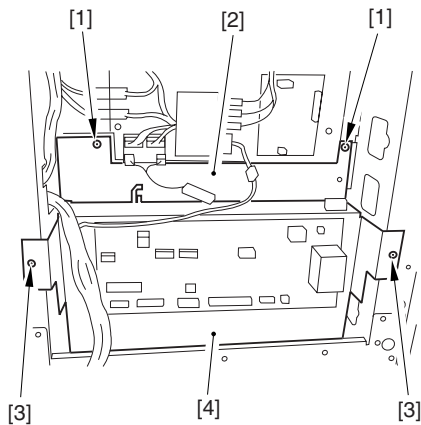

F02-804-101

b. Removing the High-Voltage Transformer Assembly (AC)

- 1) Remove the rear cover. (See 8.4.1.e.)
- 2) Disconnect the 2 connectors [1], and remove the 2 screws [2]; then, detach the HV-AC PCB [3] together with the mounting base.

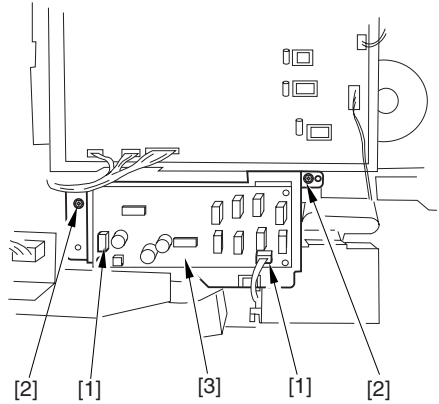

F02-804-102

- 3) Disconnect the 3 connectors [1], and remove the screw [2]; then, detach the high-voltage transformer assembly (AC) [3].

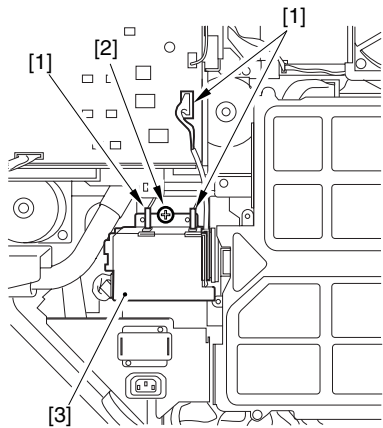

F02-804-103

c. Removing the HV-DC PCB

- 1) Remove the rear cover. (See 8.4.1.e.)
- 2) Disconnect the 5 connectors [1], and remove the 3 screws [2]; then, slide the HV-DC PCB [3] along the left and right rails [4] to detach to the front.
- 3) Detach the HV-DC PCB [3] from the cut-offs of the rails.

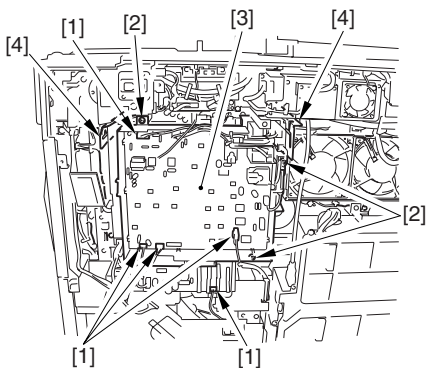

F02-804-104

d. When Replacing the HV-DC PCB

- 1) Replace the HV-DC PCB.
- 2) Check to make sure that the slide switch (SW101) on the PCB is on the UP side.
- 3) Assemble the machine; then, connect the power plug to the power outlet, and turn on the main power switch.
- 4) Enter the values (4 types) indicated on the label attached to the new HV-DC PCB in service mode.

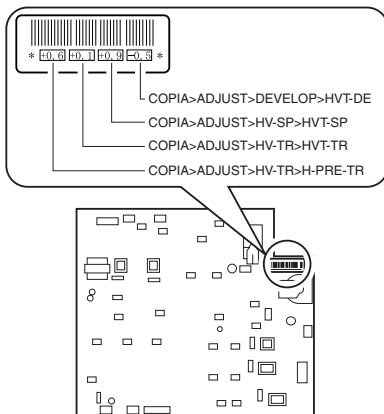

F02-804-105

- 5) Turn off and then on the main power switch.

9 Side Paper Deck-N1

9.1 Outline of the Side Paper Deck

The side paper deck is capable of accommodating as many as 3500 sheets of paper (A4/LTR/B5; 80 g/m² paper), and operates to pick up paper in response to the control signals from the machine's DC controller PCB.

F02-901-01 shows the basic construction of the side paper deck, and F02-901-02 shows the basic sequence of operation while F02-901-03 shows the drive control mechanism.

It differs from the Side Paper Deck-M1 used in the GP605 (iR600) in relation to the rotation speed of motors to support higher speed of operation. In addition, the machine uses optical sensors (instead of the GP605 (iR600)'s photointerrupters) for its pickup/feeding assembly, and uses a more durable material for its pickup/separation roller as extra considerations for higher speed of operation.

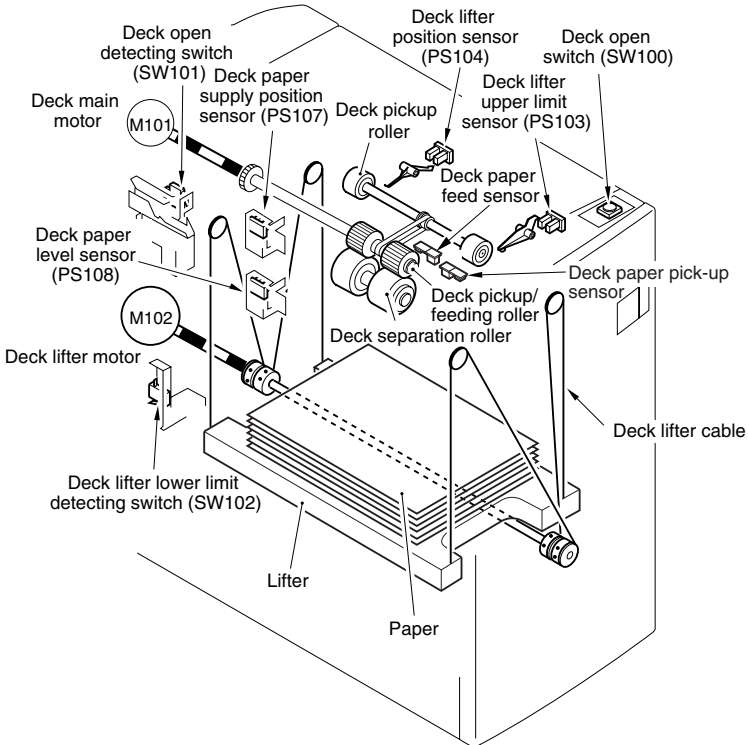

F02-901-01

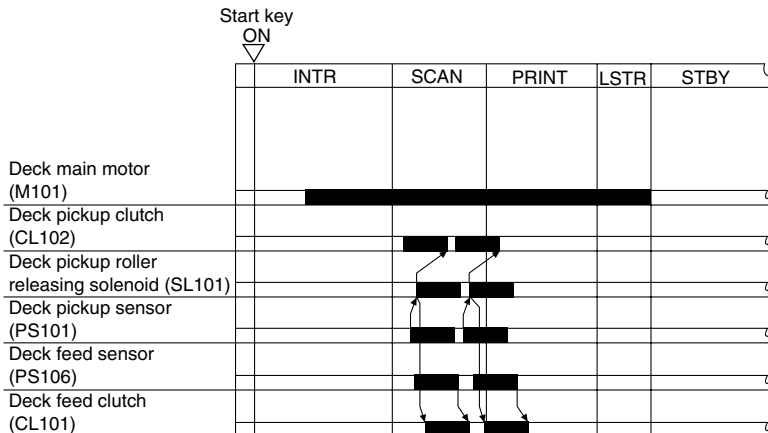

F02-901-02

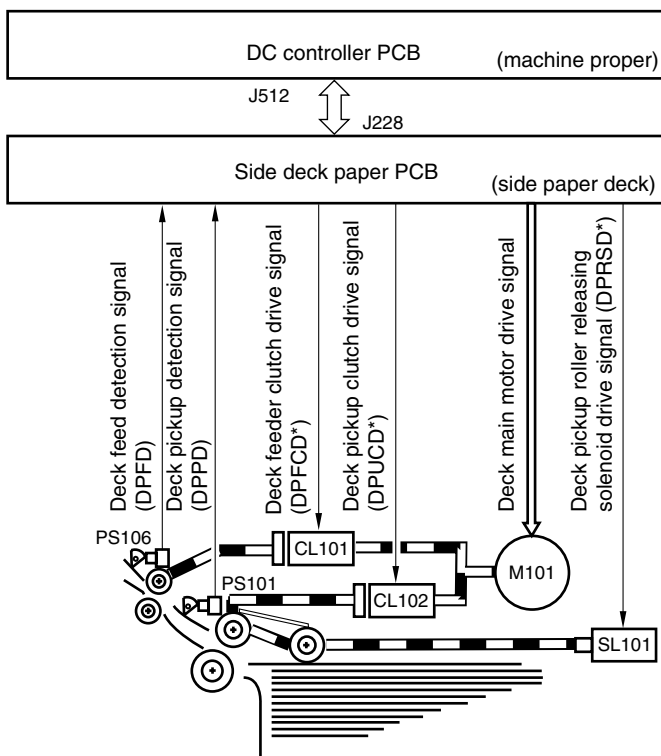

F02-901-03

9.2 Changes made to the Side Paper Deck

Unit/location	Changes from GP605 (IR600)	Purpose of change	Remarks	Reference
Deck main motor	Increased feeding speed.	To support higher speed of operation.		
Deck feeding roller	Changed the material.	To support higher speed of operation.		
Deck separation roller	Changed the material.	To support higher speed operation.		
Deck feed sensor	Made to use optical sensors.	Support higher speed of operation.	In the GP605 (IR600), photointerrupters.	
Deck pick-up sensor	Made to use optical sensors.	To support higher speed of operation.	In the GP605 (IR600), photointerrupters.	

T02-902-01

9.3 Optical Sensors

For discussions on optical sensors, see “Pickup/Feeding System.”

9.4 Disassembly/Assembly

The mechanical characteristics of the machine are as described herein; disassemble/assemble the machine as instructed and with the following in mind:

1.  Before starting any disassembly/assembly work, turn off the main power switch, and disconnect the power plug.
2. Unless otherwise specifically instructed, assemble the machine by reversing the steps used to disassemble it.
3. Identify the screws by type (length, diameter) and location.
4. To protect against static charges, some mounting screws are equipped with toothed washers. Be sure not to leave them behind.
5. As a rule, do not operate the machine with any of its parts removed.
6. If the deck is equipped with an anti-moisture heater, be sure to disconnect the power plug of the heater for safety.

9.4.1 Removing the Deck Pickup Sensor Unit

- 1) Remove the deck upper cover.
- 2) Remove the screw [1], and detach the deck pickup sensor unit [2].

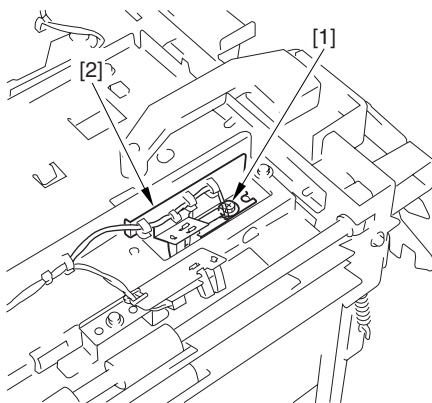

F02-904-01

- 3) Disconnect the connector [1], and free the claw to detach the deck pickup sensor [2].



When removing the scanner sensor, be sure to remove the paint used to lock the claw in place in advance to prevent breaking the claw. When mounting it, be sure the claw is not displaced or the sensor is not disoriented.

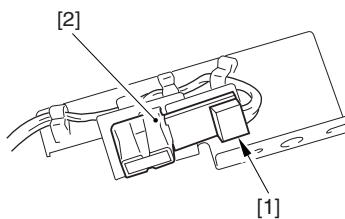

F02-904-02

9.4.2 Removing the Deck Feed Sensor Unit

- 1) Remove the deck upper cover.
- 2) Remove the screw [1], and detach the deck feed sensor unit [2].

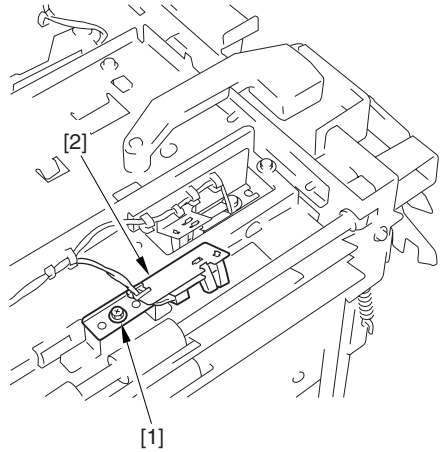

F02-904-03

- 3) Disconnect the connector [1], and free the claw to remove the deck feed sensor [2].



When removing the scanner sensor, be sure to remove the paint used to lock the claw in place in advance to prevent breaking the claw. When mounting it, be sure the claw is not displaced or the sensor is not disoriented.

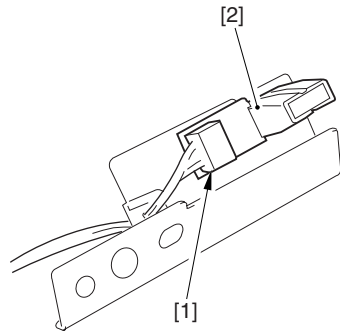

F02-904-04

CHAPTER 3

MAIN CONTROLLER

1 Basic Operation

1.1 Functional Construction

The machine may be broadly divided into the following functional blocks (controller area in the shaded block):

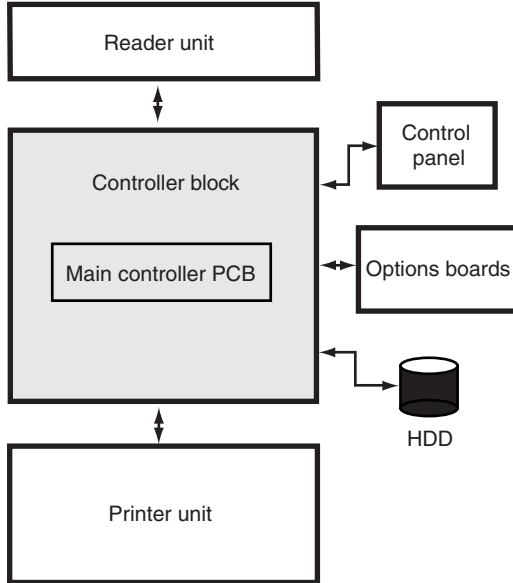

F03-101-01

1.2 Outline of the Electrical Circuitry

1.2.1 Outline

The major electrical mechanisms of the controller block are controlled by the CPU on the main controller PCB; the following table shows the functions of the IC and hard disk located around the CPU (e.g., RAM, DIMM) and of the CPU itself:

1.2.2 Main Controller PCB

Name	Description
CPU	<ul style="list-style-type: none"> • Controlling image processing of input image data from the reader unit • Controlling image processing of output image data to the printer unit • Controlling the hard disk drive • Controlling the following: network interface, DMA controller, PCI interface, ROM/RAM interface
RAM	<ul style="list-style-type: none"> • Storing temporarily program data and image data
DIMM-ROM	<ul style="list-style-type: none"> • Storing the system control program • Storing the boot program

T03-102-01 List of Functions

1.2.3 Hard Disk Drive

Name	Description
HDD	<ul style="list-style-type: none"> • Storing system software • Storing image data for the box function

T03-102-02

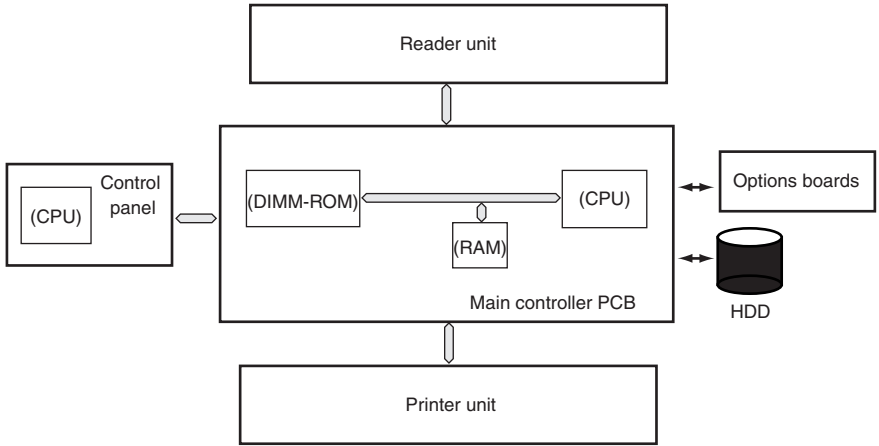

F03-102-01 Arrangement of Major PCBs

1.3 Start-Up Sequence

1.3.1 Outline

The system software used to control the machine is stored on the HDD. The CPU on the main controller PCB reads the system software from the HDD to write to the SDRAM mounted on the DIMM socket of the main controller PCB, requiring time before the control panel becomes ready for operation after the main power switch is turned on.

While the CPU reads the system software from the HDD to the SDRAM, the following screen remains in the control panel, with the progress bar on the screen indicating the changing stages of the start-up sequence:

Start-Up Screen

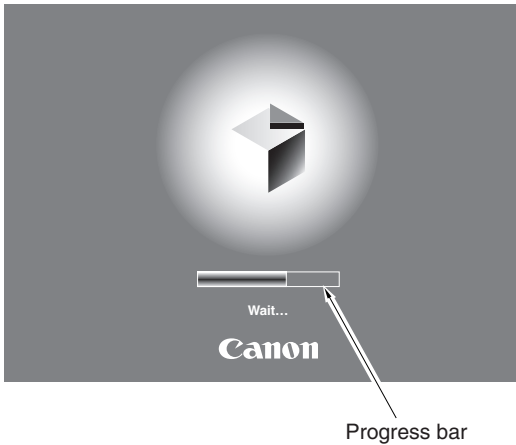

F03-103-01

1.3.2 Start-Up Sequence

When the main power switch is turned on, the CPU on the main controller PCB first executes the self-diagnosis program stored in the boot ROM.

The self-diagnosis program checks the condition of the SDRAM and the HDD; if a fault is found, it will indicate an error code in the control panel.

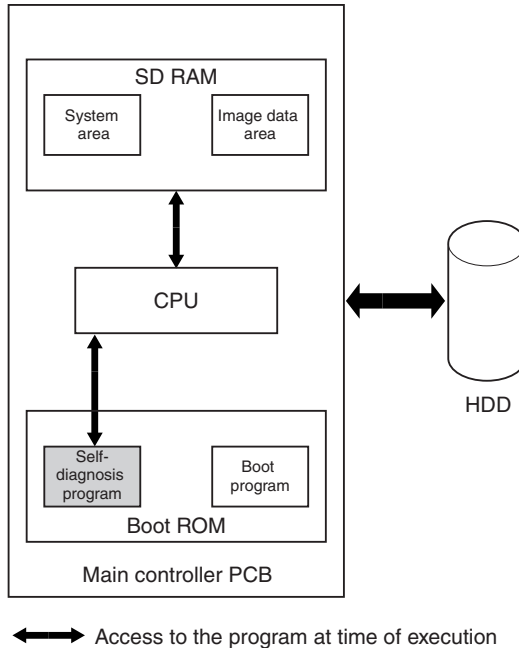

F03-103-02



E601-0000, -0001

Indicates an error in image transfer data.

E602-0001, -0002

Indicates a write/read error.

When the self-diagnosis ends normally, the boot program stored in the boot ROM starts up to read the system software from the HDD to write to the system area of the SDRAM.

When the write operation ends, the system software in the SDRAM starts up to initialize the components of the machine (at the end of which the normal operating screen will appear in the control panel) and, at the same time, the LED lamp of the Start key will change from red to green to indicate that the machine is ready to accept a job.

The system software of the machine consists of multiple modules, and specific modules as needed at specific times are called into the system area of the SDRAM for execution.

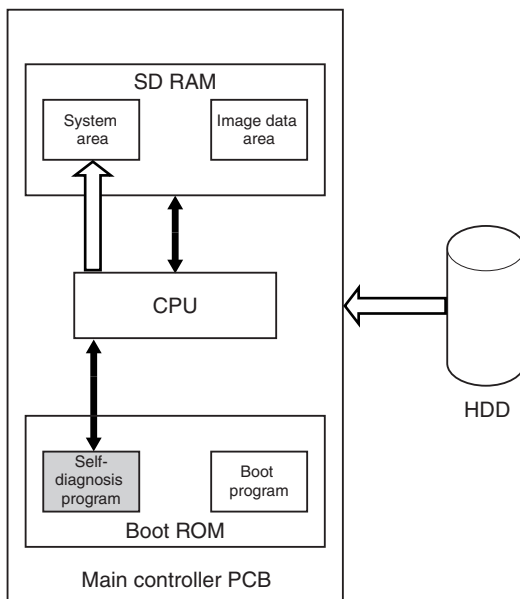

↔ : Access to the program during execution

⇐ : Flow of the system program

F03-103-03

1.3.3 Construction of the System Software

The system software of the machine can broadly be divided into system modules (for control) and language modules (for indication on the control panel LCD).

To upgrade the machine, you will have to upgrade both the system modules and the language modules.

1.4 Inputs/Outputs the Major PCBs

1.4.1 Connection Diagram of the Major PCBs

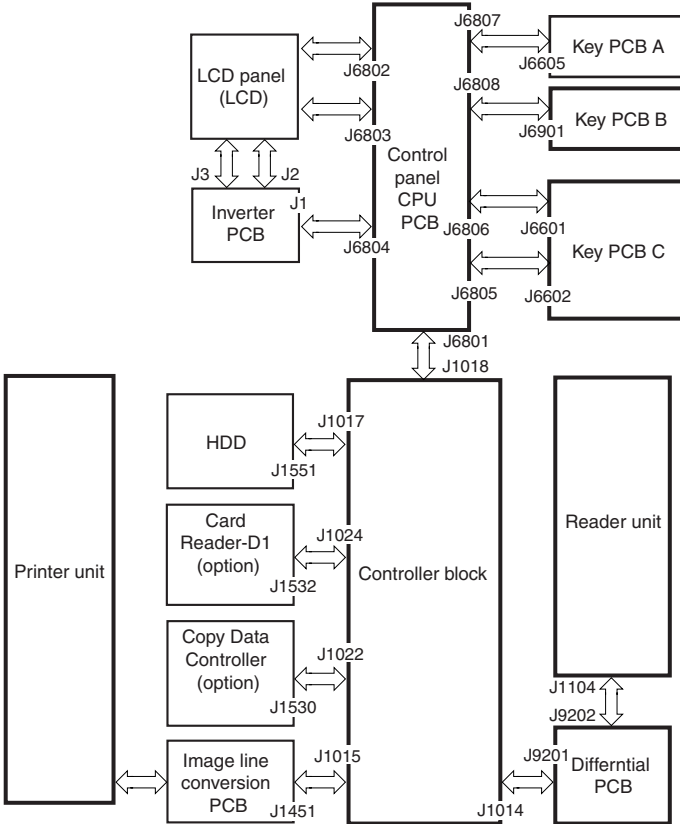

The symbol \longleftrightarrow in the diagram indicates the connection between major PCBs, not the direction of signals.

F03-104-01 Connection Diagram of the Major PCBs

2 Digital Image Processing

2.1 Outline

The digital processing and controlling of image memory of the machine are performed by the main controller PCB. The following is a block diagram showing its digital image processing:

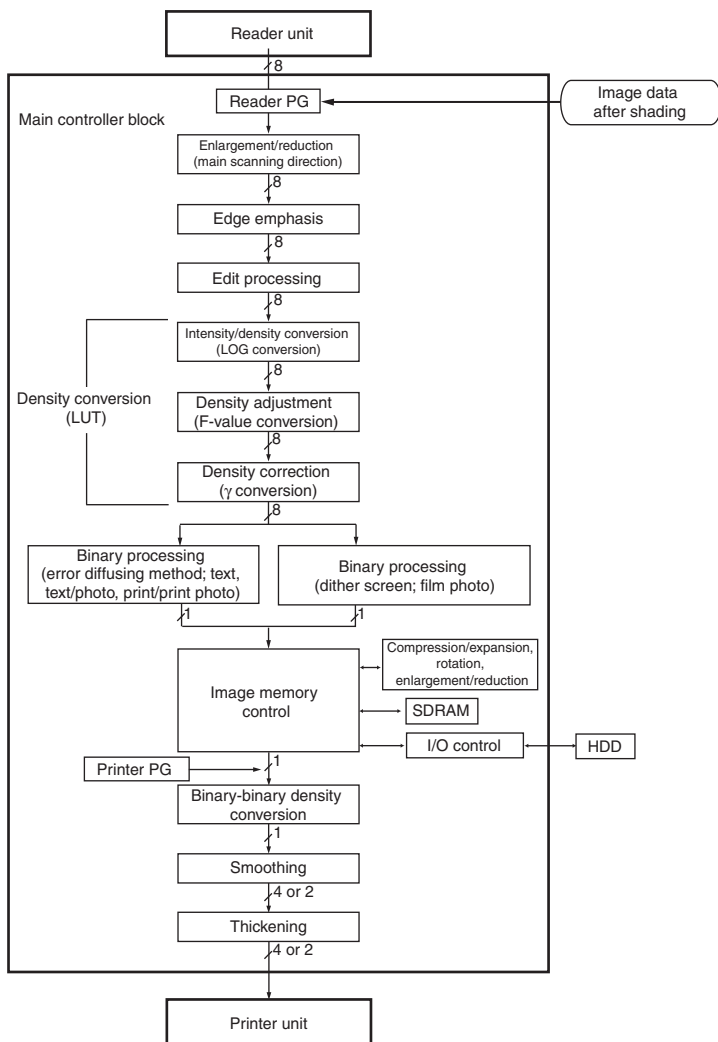

F03-201-01 Block Diagram

2.2 Input Image Processing

Input image data from the reader unit is processed as follows:

2.2.1 Image Data from the Reader Unit

The image signals from the reader unit is subjected to shading correction and turned into 8-bit, 256-gradation intensity signals.

The input is from 2 signal lines: even-bit pixels and odd-bit pixels.

2.2.2 Enlargement/Reduction (main scanning direction)

Image data is processed when it is written into or read from image memory for enlargement or reduction.

2.2.3 Edge Emphasis

Edge emphasis is performed so that the text, text/photo, print photo, or print photo images may be made sharp so as to reduce moiré.

2.2.4 Edit Processing

Edit processing is performed to enable the following: blanking/framing, negative/positive reversal, slant, mirror, fold, repeat.

2.2.5 Density Conversion (LUT)

In this block, intensity signals are converted into density signals; in addition, processing is also performed so that the output density curve best suited to each mode is obtained.

a. LOG Conversion

Using a LOG conversion table, the intensity signals are converted into toner density signals in relation to reflected light.

b. Density Adjustment (F-value conversion)

Using an F-value table selected in relation to the setting of the Density key in the control panel, density adjustment is performed. It, however, will not be performed in memory copy mode.

c. Density Conversion (γ conversion)

Using a γ conversion table, density correction is performed for text, text/photo, print photo, or film photo mode.

2.2.6 Binary Processing (error diffusion method T-BIC)

The error diffusion method (TBIC) is used to control the texture, subjecting data to binary processing so that it becomes most suited for printing. Specifically, the 8-bit image density signals of text, text photo, or print photo mode are converted into 1-bit image density signals (binary).

2.2.7 Binary (dither screen method)

The dither screen method is used to control the texture, subjecting the data to binary processing. Specifically, the 8-bit image density signals in film photo mode are converted into 1-bit image density signals (binary).

Although binary, images are produced in 144 gradations owing to the 12×12 dither screen processing.

2.3 Controlling the Image Memory

The binary image data is controlled in image memory as follows:

2.3.1 Compression/Expansion, Rotation, and Enlargement/Reduction

Binary images are processed for compression/expansion (for electronic sorting), rotation, or resolution conversion.

2.3.2 SDRAM

The image data is temporarily stored as part of image memory control.

2.4 Output Image Processing

The output image data sent to the printer unit is processed as follows:

2.4.1 Smoothing

a. Read Image Output

In the case of text/print photo mode, the 600×600 -dpi input images are subjected to smoothing for conversion into 1200-equivalent $\times 600$ dpi images.

In smoothing, the image data is compared to several hundred templates of 7×7 -pixel matrices for replacing of pixels in question.

Notch processing is also performed in this block, as a pattern unique to read images.

b. Printer (PDL) Image Output

Smoothing most suited to PDL is performed, converting 300×300 -dpi or 600×600 -dpi data into 2400-equivalent $\times 600$ -dpi data.

2.4.2 Thickening (PDL output only)

If selected using a printer driver, thickening is performed to thicken fine lines for better reproduction.

PDL output images are thickened by adding $1/2$ pixels (1200 dpi) to the top of a horizontal line or $1/2$ pixels (1200 dpi) to the right of a vertical line.

2.4.3 Binary-Binary Conversion (read image output only)

Binary-binary density conversion is used as an auxiliary means to correct density during copying operation.

3 Soft Counters

The machine is equipped with soft counters to keep count of prints it makes. The counter readings are checked by pressing the Check key in the control panel.

The counters are controlled by the main controller PCB, and the readings are incremented when the following sensors detect paper during copying or printing.

Copying/printing operation	Counter sensor
Single-sided	Finisher delivery sensor
Double-sided	1st side: PS14 2nd side: finisher delivery sensor

T03-300-01

The counter mechanism consists of 16 items for large-size and small-size sheet, each with 8 mode items.

Copying/printing mode	Large-size	Small-size*1
Load copy	A	B
PDL print	C	D
Box print	E	F
Remote copy print	G	H
FAX reception print*2	I	J
Report print	K	L
Double-sided print	M	N
Scan	O	P

T03-300-02

*1: At time of shipment from the factory, B4 or smaller; to count B4 as large-size, use service mode.

*2: Not counted; the machine is not equipped with fax functions.

The counters are set as follows when the machine is shipped from the factory to suit its country of installation:

Counter	Description*1	Default		Default change*2
		100V model	208V/230V model	
Counter 1	Total (A through L)	ON	ON	Fixed
Counter 2	Total large (ACEGIK)	OFF	ON	May be changed
Counter 3	Copy 1 (ABGH)	OFF	ON	May be changed
Counter 4	Copy 1 large (AG)	OFF	ON	May be changed
Counter 5	Print 1 total (CDEF)	OFF	OFF	May be changed
Counter 6	FAX total (IJ)	OFF	OFF	May be changed

T03-300-03

- *1: The notation within parenthesis indicates modes supported by the basic counter (see T02-300-02).
- *2: To change the contents of a counter or to enable/disable indication, use service mode. (This, however, does not apply to counter 1, whose data cannot be changed.)

4 Controlling the Power Supply

4.1 Outline

The main controller PCB controls the power supply for the following 5 power supply modes except for power-off mode, initiated by turning off the main power switch.

- Standby mode (normal operation)
- Power save mode
- Low power mode
- Sleep mode
- Off mode

4.2 Power Supply Mode

The machine affects its power supplies as follows: +3.3V all night (3.3 VB), +3.3 V non-all night (3.3 VA), +5 V non-all night (5 V), +24 V:

Mode	+3.3 V all night	+3.3 V non-all night	+5 V	+24 V
Standby	○	○	○	○
Power save	○	○	○	○
Low power	○	○	○	○
Sleep	○	×	×	×
Off	○	×	×	×
Power off	×	×	×	×

T03-402-01

4.3 Standby Mode (normal operation)

In standby mode, the machine is in normal operation or is ready to start normal operation at any moment; in other words, most of power supplied are in operation.

Not only the main controller PCB, but also the reader unit, printer unit, and control panel are all ready for communication and control.

4.4 Power Save Mode

Most of power supplies are in operation (same as in standby mode).

According to the selected rate of saving, the control temperature of the fixing assembly for standby is lowered to reduce power consumption (140°C for 200V model; 198°C for 208V/230V model, for which no specifications are provided).

4.5 Low Power Mode

In low power mode, the fixing assembly temperature is kept low (140°C for 200V model, 198°C for 208V/230V model), and the power consumed by the reader unit and the printer unit is lowered to reduce the total power consumption for the machine.

4.5.1 Shift from Standby Mode (standby → low power)

A shift from standby mode to low power mode is made for the following:

- Standby mode has continued for a specific period of time, i.e., a specific period of time as may be selected in user mode.

4.5.2 Shift to Standby Mode (low power → standby)

A shift from low power mode to standby mode is made on the following condition:

- The control panel power switch (soft switch) is turned on.
- PDL data has been received from the network (parallel port); in terms of electrical mechanisms, the control panel is OFF as in standby mode.

4.6 Sleep Mode

In sleep mode, only the +3.3V all-night (3.3 VB) power supply is ON. In this mode, the CPU on the main controller PCB is also at rest (in wait for an interrupt and not running the program) to reduce power consumption.

This mode is used only when the machine is configured as a printer equipped with a network print option and a PDL print option.

4.6.1 Shift from Standby Mode (standby → sleep)

A shift from standby mode to sleep mode is made on the following condition:

- The control panel power switch (soft switch) is off.
- Standby mode has lasted for a specific period of time, i.e., a specific period of time as may be selected in user mode.

4.6.2 Shift from Low-Power Mode (low power → sleep)

A shift from low power mode to sleep mode is made on the following condition:

- The control panel power switch (soft switch) is off.
- Low power mode has lasted for a specific period of time, i.e., a specific period of time as selected in user mode.

4.6.3 Return to Standby Mode (sleep → standby)

A shift from sleep mode to standby mode is made on the following condition:

- The control panel power switch (soft switch) is on.
- PDL data has been received from the network (parallel port); in electrical terms, the control panel is off as in standby mode.

4.7 OFF Mode

In OFF mode, the +3.3V all-night power supply of the CPU itself is off, leaving a minimum logic circuitry of the main controller PCB on.

This mode is used when the machine is configured as a copier without a network print option or a PDL print option.

4.7.1 Shift from Standby Mode (standby → OFF mode)

A shift from standby to OFF mode is made on the following condition:

- The control panel power mode (soft switch) is off.
- Standby mode has lasted for a specific period of time, i.e., a specific period of time as selected in user mode.

4.7.2 Shift from Low-Power Mode (low-power → OFF mode)

A shift from low power mode to OFF mode is made on the following condition:

- The control panel power switch (soft switch) is off.
- Low power mode has lasted for a specific period of time, i.e., a specific period of time as selected in user mode.

4.7.3 Return to Standby Mode (OFF mode → standby)

In OFF mode, a command from outside cannot cause a shift to standby; the control panel power switch (soft switch) or the main power switch must be turned off and then on to return to standby mode.

The operation at time of return will be exactly the same as when the machine is first turned on.

4.8 Power Supply OFF Mode

In power supply OFF mode, the machine remains in a state exactly the same as when its main power switch is off.

To return from power OFF mode, the main power switch must be turned on, in response to which the machine will automatically enter standby mode.

CHAPTER 4

INSTALLATION

1 Selecting the Site

The site of installation must meet the following requirements; if possible, visit the user's before delivery of the machine:

1. The site must provide with a power outlet that is rated to suit the machine and that can be used exclusively by the machine; 200V Model (180 to 220V, 12A or more), 208V Model (188 to 228V, 12A or more), 230V Model (198 to 264V, 13A or more).
2. The site must be between 15° and 30°C in temperature and between 5% and 80% in humidity. Particularly, be sure to avoid areas near water faucets, water boilers, humidifiers, and refrigerators.
3. The site must not be near a source of fire, subject to dust or ammonium gas, or exposed to direct rays of the sun. As necessary provide curtains.
4. The level of ozone generated by the machine will not affect the health of individuals around it. Some, however, may find its odor unpleasant as while remaining in contact with it for long hours. Be sure that the room is well ventilated.
5. Make sure that the feet of the machine will remain in contact with the floor, and the machine will be kept level.
6. Make sure that the machine will be at least 10 cm away from any walls, allowing enough space for work.

7. Make sure that the area is well ventilated.

If multiple machines are installed, in particular, be sure that the exhaust of another will not be drawn by the machine.

Be sure also not to install a machine near an air vent.

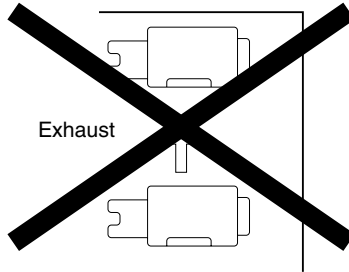

Wrong 1

F04-100-01

(In general, the silicon gas (vapor of silicone oil from the fixing assembly) tends to soil the corona charging wire, reducing its life. This is particularly true of a low humidity environment.)

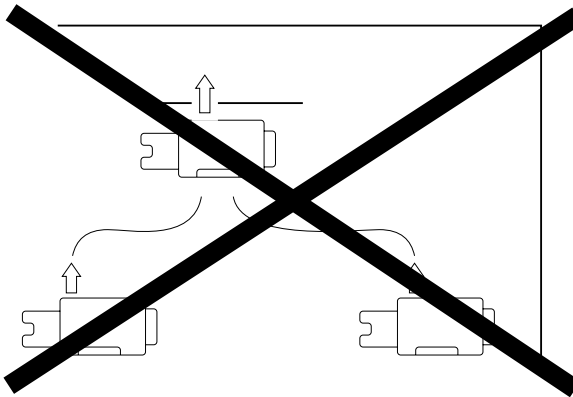

Wrong 2

F04-100-02

Outline of the Work Space

Use the following as a guide when considering space for service work:

■ Copier + Finisher

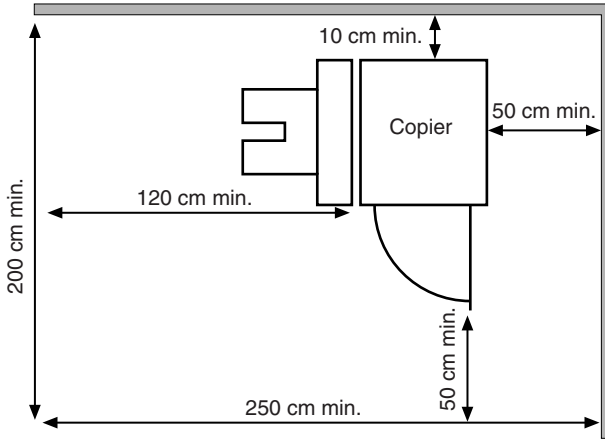

F04-100-03

■ Copier + Finisher + Side Paper Deck

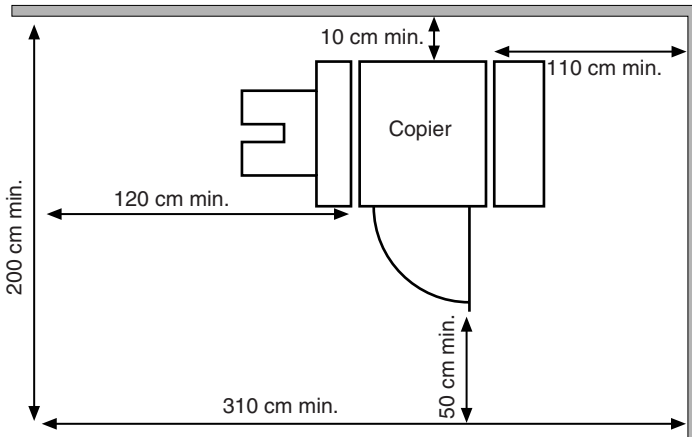

F04-100-04

2 Unpacking and Installation

2.1 Points to Note Before Starting the Work

Go through the following before starting to install the machine:



1. If the machine is moved from a cold to warm place, it can develop condensation in the form of droplets of water on its metal surfaces. Use of the machine while it suffers from condensation can lead to image faults. If the machine has been moved from a cold to warm place, be sure to leave it for 1 hour or more without unpacking so that it becomes fully used to the new place.
 2. If stairs are used to move the machine into or out of the site of installation, keep the following in mind:
 - a. Take out the ADF, fixing/feeding assembly, holding tray assembly, and copy paper, and carry them separately from the main body.
 - b. When lifting the machine, do not use the grips on the pickup assembly/delivery assembly. Instead, be sure to support the machine at four corners of its bottom.
 3. Shift up the 2 adjusters (front) found on the bottom of the machine to be sure that they are unlocked. The adjusters can slip out of the bottom of the machine because of vibration during transportation. Take care not to loose them.
 4. Be sure to work as a group of three or more. When removing the pad, in particular, one must hold the rear grip and one the front grip, while the other removes the pad.
 5. Be sure to remove the accessories (side paper deck, finisher, paper folding unit) when moving the machine into or out of the site of installation to prevent damage.
-

2.1.1 Attachments

Before starting the installation work, check to be sure that none of the following is missing:

0. Developing assembly	1 pc.	T. Service Book	
1. Developing assembly locking plate		(200V model only)	1 pc.
.....	1 pc.	U. User Card (200 V model only)	1 pc.
2. Control panel unit	1 pc.	V. Warranty Card	
3. Upper arm	1 pc.	(English; 208V model only)	1 pc.
4. Lower arm	1 pc.	W. Warranty Card	
5. Upper arm cover	1 pc.	(French; 208V model only)	1 pc.
6. Lower arm cover	1 pc.	X. Drum Warranty Card	
7. Harness clip	1 pc.	(English; 208V model only)	1 pc.
8. Ferrite core (230V model only)	1 pc.	Y. Drum Warranty Card	
9. ADF delivery tray unit	1 pc.	(French; 208V model only)	1 pc.
A. Cassette size label	2 pc.	Z. Registration Card	
B. Universal cassette label	2 pc.	(English; 208V model only)	1 pc.
C. Size plate	2 pc.	a. Registration Card	
D. Deck size label	2 pc.	(French; 208V model only)	1 pc.
E. 3-hole paper set label	1 pc.	b. Installation Check Card	
F. Grip	1 pc.	(208V model only)	1 pc.
G. Non-inch block	6 pc.	c. Manual Feed Set label	
H. Toner (200/230V, ITA model)	1 pc.	(208/230V model)	1 pc.
J. Index paper attachment	1 pc.	d. RS tightening screw (M4x10)	
K. Backing	1 pc.	3+6 pc.
L. Attachment sheet	1 pc.	e. TP screw (M4x6)	6 pc.
M. Deck locking plate	1 pc.	f. Binding screw (M4x6)	1 pc.
N. Copyboard base		g. Binding screw (M4x14)	5 pc.
(208V model only)	1 pc.	h. P tightening screw (M4x10)	2 pc.
P. User's Guide	1 pc.	j. W sems screw (M4x12)	1 pc.
Q. Copier Manual	1 pc.	k. Flat-head screw (M4x10)	1 pc.
R. Box Guide	1 pc.	m. iR105 Installation Procedure	1 pc.
S. QR sheet (200V model only)	1 pc.		

2.2 Unpacking

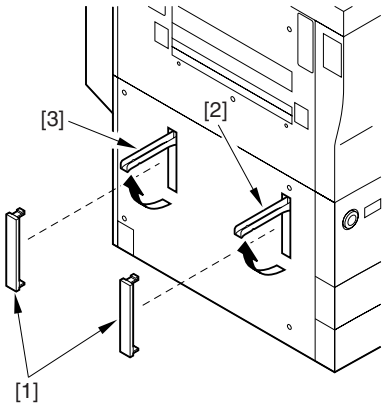
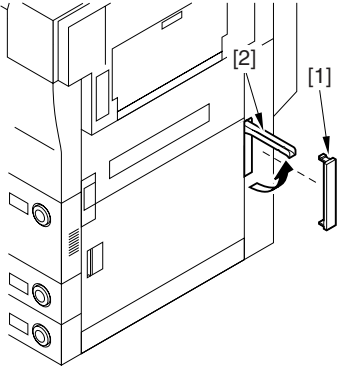
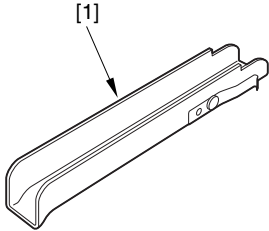
No.	Work	Checks/remarks
1	<p>Unpack the copier.</p> <p>Remove the plastic bag.</p> <p>Insert a flat-blade screwdriver into the top of the grip cover [1] (2 pc.; front, rear) on the left of the machine, and remove it.</p> <p>Shift up the grips at the front [2] and the rear [3].</p>	 <p>F04-202-01</p>
2	<p>Remove the grip cover (rear) [1] from the right of the machine with a flat-blade screwdriver, and shift up the grip [2] at the rear.</p>	 <p>F04-202-02</p>
3	<p>Remove the grip [1] from the box that comes with the machine.</p>	 <p>F04-202-03</p>

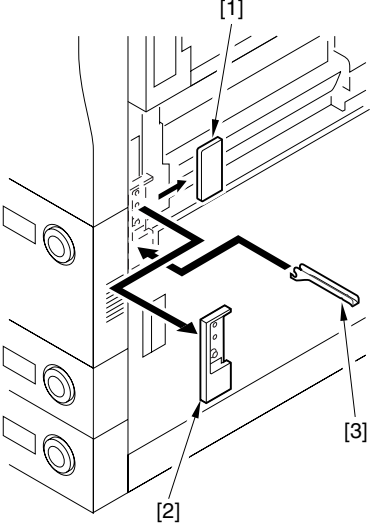
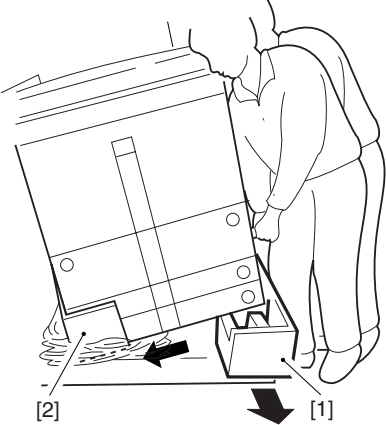
No.	Work	Checks/remarks
4	<p>Open the right upper cover, and slide the face cover (small) [1] to the rear to detach; then, detach the face cover (large) [2].</p> <p>Fit the grip [3] removed in step 3 to the front.</p> <p>Close the right upper cover.</p>	 <p>F04-202-04</p>
5	<p>Holding the grips on the pickup side (front, rear) of the copier, lift the machine slightly, and remove the pad [1]. At this time, move the plastic bag [2] toward the pad side.</p>	 <p>F04-202-05</p>

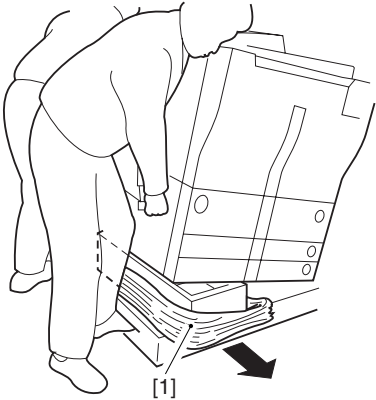
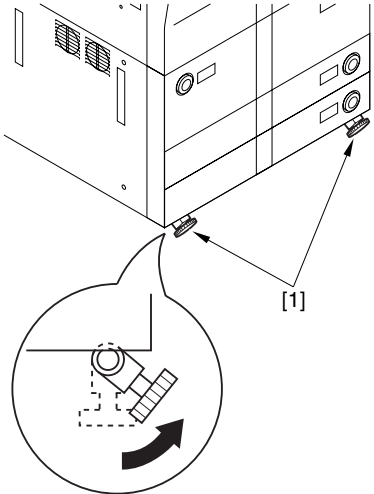
No.	Work	Checks/remarks
6	<p>Holding the grips on the delivery side (front, rear) of the copier, lift the machine slightly, and remove the remaining pad and the plastic bag [1] at the same time.</p>	 <p>The diagram shows a person from behind, lifting the front of a copier. A dashed line indicates the position of a pad and plastic bag that is being removed. A thick black arrow points downwards from the bag area, labeled with [1].</p> <p>F04-202-06</p>
7	<p>Shift up the 2 adjusters (front) [1] found on the bottom of the copier, and check to make sure that they are unlocked.</p>	 <p>The diagram shows a close-up of the bottom of the copier. Two adjusters are indicated by arrows and labeled [1]. A circular inset provides a magnified view of one adjuster, showing a curved arrow indicating it should be shifted upwards.</p> <p>F04-202-07</p>

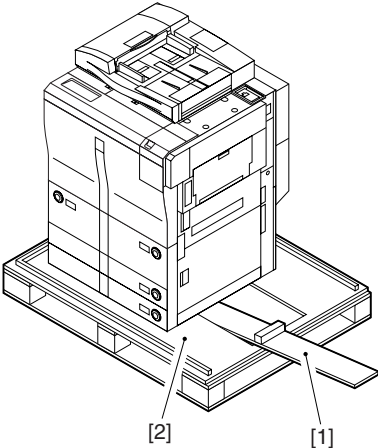
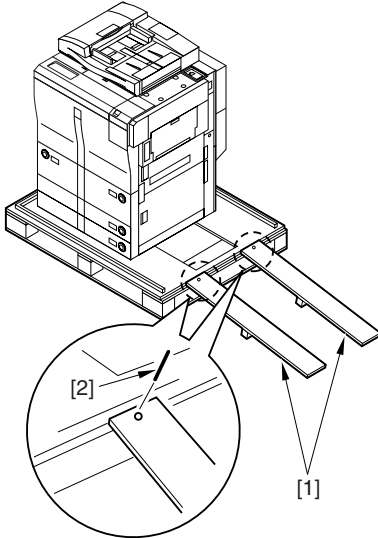
No.	Work	Checks/remarks
8	<p>Take out the two slope plates [1] from the center of the skid [2].</p>	 <p style="text-align: center;">F04-202-08</p>
9	<p>Detach the 2 pins taped to the slope plates.</p> <p>Turn over the slope plates [1], and match the pins [2] hole in the skid and the pin hole in the slope plate; then, fit the pin [2] (1 pc. each).</p> <p>Holding the grips (front, rear) on the delivery side of the copier, slide the copier down the slope plates to move it off the skid.</p>	 <p style="text-align: center;">F04-202-09</p>
10	<p>For the cardboard box that comes with the machine, take out the parts and the attachments. Check to make sure that none of the foregoing items is missing.</p>	

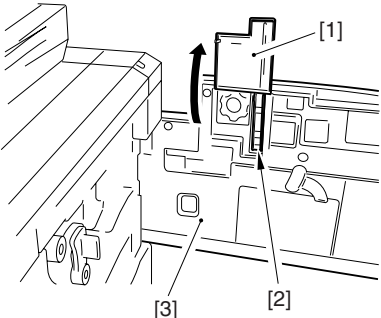
No.	Work	Checks/remarks
11	<p>Open the front cover, and then open the compartment cover [1]; put the grip [2] used in step 4 inside the compartment (found behind the front cover [3]) for storage.</p> <p>Close the compartment cover [1], and then close the front cover [3].</p>	 <p>F04-202-10</p>
12	<p>Mount the removed face covers to the right side and the left side of the machine.</p> <p>Open the right upper cover, and mount the face cover (small) and the face cover (large).</p> <p>Close the right upper cover.</p>	



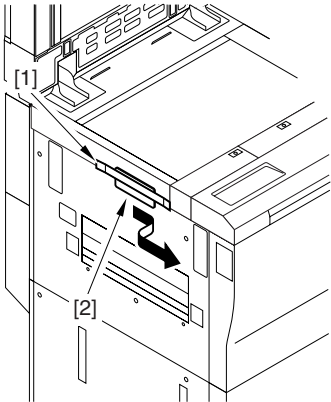

If condensation is found on the outside or inside of the copier, stop the work immediately, and wait until it becomes fully used to the room temperature. If no condensation is found, continue the work.

2.3 Mounting the Scanner

No.	Work	Checks/remarks
1	Remove the packing tape from the copier.	
2	Open the ADF. Remove the copyboard glass protective pad.	
3	Remove the packing tape [1] from the scanner fixing. Slide the scanner fixing [2] to the front to detach. (Store away the fixing, as you will need it to secure the scanner when relocating the machine.)	 <p>The diagram shows a perspective view of the scanner unit. A line labeled [1] points to a piece of packing tape on the top surface of the scanner. A line labeled [2] points to a scanner fixing mechanism on the front panel. A thick black arrow indicates the direction to slide the fixing [2] forward. Below the diagram is the reference code F04-203-01.</p> <p data-bbox="740 826 865 850">F04-203-01</p>

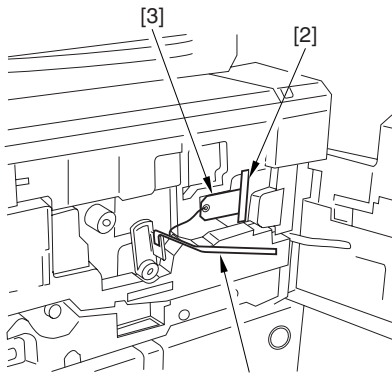
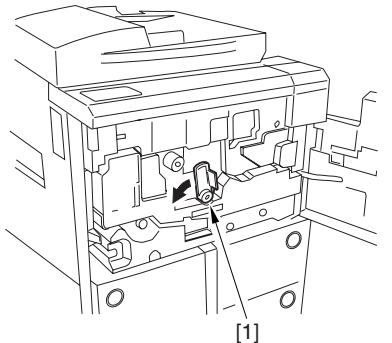
2.4 Installing the Fixing Assembly

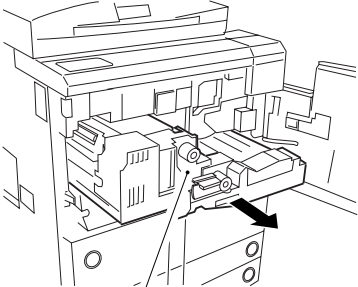

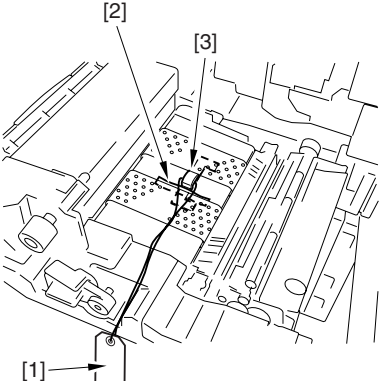
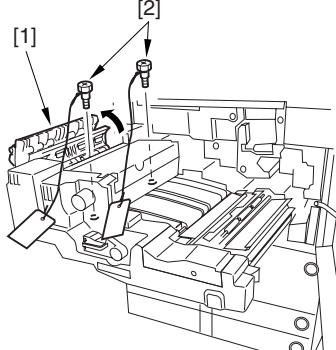
No.	Work	Checks/remarks
1	Open the front cover.	
2	<p data-bbox="152 288 535 375">Remove the double-sided tape [1] from the inside cover and the tape [2] used to keep the tag [3] in place.</p> <p data-bbox="152 790 535 901">Shift the fixing/feeding assembly releasing lever [1] in the direction of the arrow (left) to release the transfer/separation charging assembly.</p>	 <p data-bbox="694 710 817 742">F04-204-01</p>  <p data-bbox="694 1149 817 1181">F04-204-02</p>

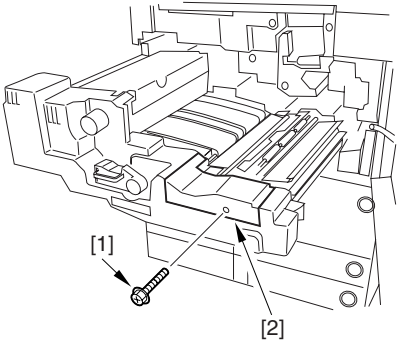
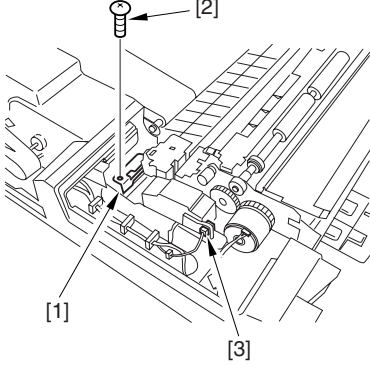

No.	Work	Checks/remarks
	<p>Slide out the fixing/feeding unit [1] to the front.</p>	 <p>[1] F04-204-03</p>
<p>3</p>	<p>Remove the tag [1] and tape [2] from the fixing/feeding assembly.</p> <p>Remove the separation releasing member [3].</p> <div style="border: 1px solid black; padding: 5px; margin-top: 10px;">  <p>Remove all foreign matter (e.g., tape glue) from the feed belt.</p> </div>	 <p>[2] [3] [1] F04-204-04</p>
<p>4</p>	<p>Remove the tape used to keep the tag in place; then, open the fixing/feeding unit top [1], and remove the two screws [2] from the front and the rear (fixing nip release).</p> <p>Close the fixing/feeding unit top [1].</p>	 <p>[1] [2] F04-204-05</p>

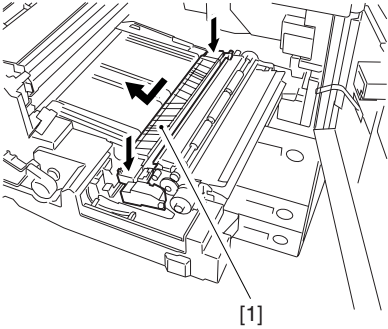
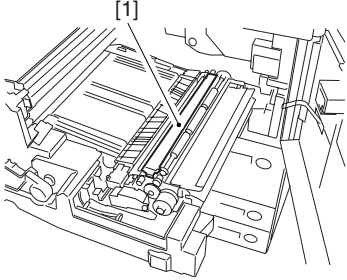
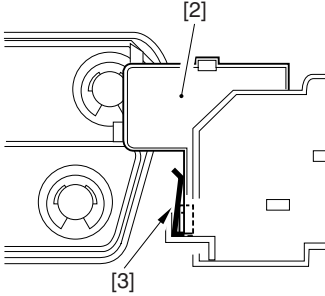
2.5 Mounting the Charging Assemblies

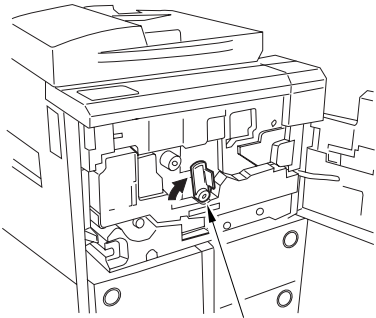
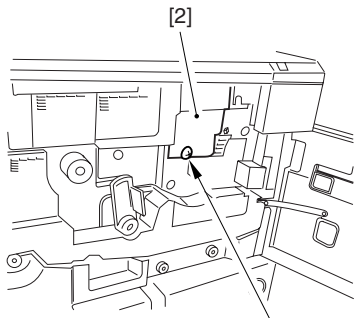
No.	Work	Checks/remarks
1	Remove the screw [1], and detach the transfer/separation charging assembly front cover [2].	 <p>F04-205-01</p>
2	Remove the fixing [1] (1 screw [2]), and disconnect the connector [3].	 <p>F04-205-02</p>

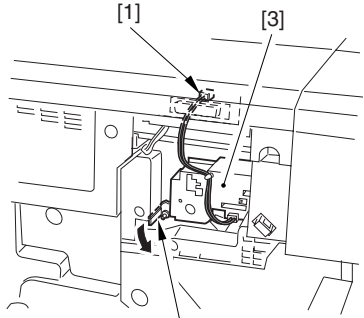

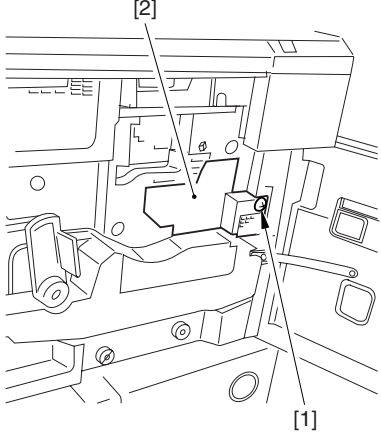
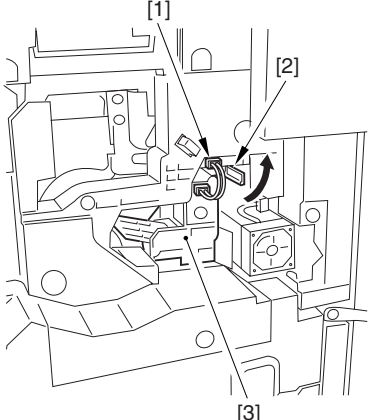
No.	Work	Checks/remarks
3	<p>While pressing the front and the rear of the transfer/separation charging assembly [1], pull it about 1 cm to the front; then, detach it to the rear upper left.</p> <p>Using alcohol, clean the transfer/separation charging wire.</p>	 <p>F04-205-03</p>
4	<p>While observing the following, mount the transfer/separation charging assembly:</p> <ul style="list-style-type: none"> • The solvent must be fully dry. • The gut wire is not brought into contact with the transfer guide [1] to avoid a cut. • The ground plate [2] is found outside the charging assembly [3] frame as shown. 	 <p>F04-205-04</p>  <p>F04-205-05</p>
5	<p>Connect the connector of the transfer/separation charging assembly, and fit the fixing.</p>	

No.	Work	Checks/remarks
6	<p>Mount the transfer/separation charging assembly front cover with a screw.</p> <p>Push in the fixing/feeding assembly inside the machine, and shift the fixing/feeding assembly releasing lever [1] to SET position.</p>	 <p style="text-align: center;">[1]</p> <p style="text-align: center;">F04-205-06</p>
7	<p>Remove the screw [1], and detach the primary charging assembly front cover [2].</p>	 <p style="text-align: center;">[2]</p> <p style="text-align: center;">[1]</p> <p style="text-align: center;">F04-205-07</p>
8	<p>Disconnect the connector [1], and release the locking lever [2] of the primary charging assembly; then, take out the charging assembly [3].</p> <p>Using alcohol, clean the primary charging wire and grid wire.</p> <div style="border: 1px solid black; padding: 5px; margin-top: 10px;">  <p>Do not mount it until the solvent is fully dry. Wait until later.</p> </div>	 <p style="text-align: center;">[1]</p> <p style="text-align: center;">[3]</p> <p style="text-align: center;">[2]</p> <p style="text-align: center;">F04-205-08</p>

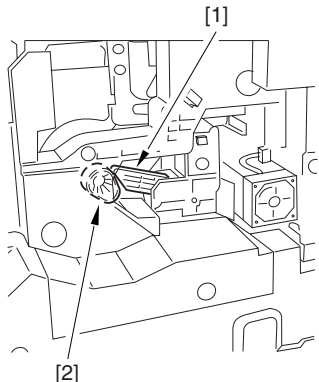
No.	Work	Checks/remarks
9	Remove the screw [1], and detach the pre-transfer change assembly front cover [2].	 <p style="text-align: center;">F04-205-09</p>
10	<p>Disconnect the connector [1], and release the locking lever [2] of the pre-transfer charging assembly; then, take out the charging assembly [3].</p> <p>Using alcohol, clean the pre-transfer charging wire.</p>	 <p style="text-align: center;">F04-205-10</p>
11	<p>With the lock released, fit the primary charging assembly, and connect the connector.</p> <div style="display: flex; align-items: center; margin-top: 10px;">  <div style="border: 1px solid black; padding: 5px; width: fit-content;"> <p>Check to make sure that the solvent is fully dry.</p> </div> </div>	

No.	Work	Checks/remarks
12	<p>With the lock released, fit the pre-transfer charging assembly, and connect the connector.</p> <div style="display: flex; align-items: center; margin-top: 10px;">  <ul style="list-style-type: none"> Check to make sure that the solvent is fully dry. Check to make sure that the one-way arm [1] of the pre-transfer charging assembly is on the eccentric cam [2]. </div>	 <p style="text-align: center; margin-top: 10px;">F04-205-11</p>
13	<p>Mount the primary charging assembly cover and the pre-transfer charging assembly cover with a screw (1 pc. each).</p>	
14	<p>Close the front cover.</p>	

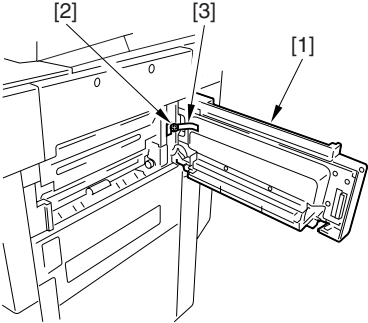
2.6 Checking the Developing Assembly

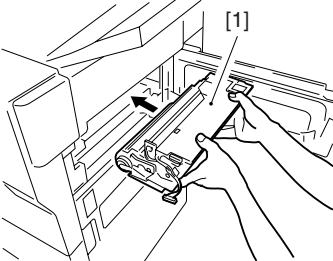
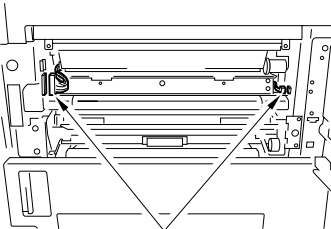
No.	Work	Checks/remarks
1	<p>Open the manual feed tray unit [1], and remove the screw [2] from the door tape [3].</p> <hr/> <p> Do not open the manual feed tray unit too wide; otherwise, the door tape may tear.</p>	 <p>F04-206-01</p>
2	<p>Take out the developing assembly from the package that comes with the machine.</p> <p>Turn the developing cylinder by hand to check it for scratches.</p>	
3	<p>Holding the developing assembly [1] as shown, mount it to the machine.</p> <hr/> <p> When mounting the developing assembly, fit it from a high position, and take care not to bring the developing cylinder into contact with the plate of the developing assembly base.</p> <hr/> <p>Connect the 2 connectors [1].</p>	 <p>F04-206-02</p>  <p>[1] F04-206-03</p>

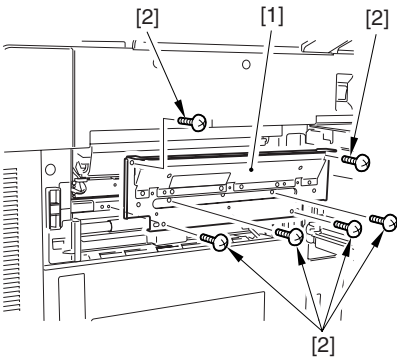
No.	Work	Checks/remarks
4	<p>Secure the developing assembly locking unit [1] with the 6 TP screws [2] (M4x6; black) that come with the machine.</p> <p> Be sure that the developing assembly locking unit is firmly in contact and is free of displacement to avoid image faults. (Particularly, it must not ride over the boss found at the bottom.)</p>	 <p>F04-206-04</p>
5	<p>Fit the previously removed screw to the door tape of the manual feed tray cover. (Keep the manual tray cover open.)</p>	

2.7 Mounting the Pickup Assembly

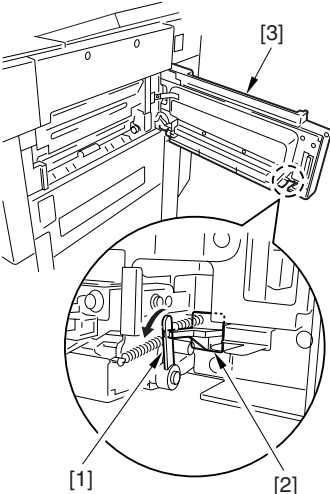
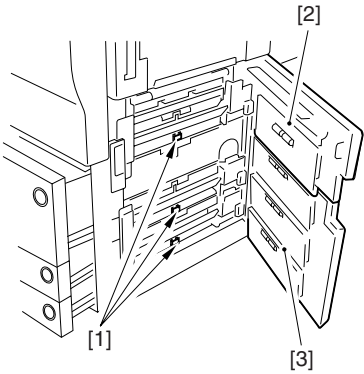
No.	Work	Checks/remarks
1	<p>Shift down the lever [1] in the direction of the arrow, and remove the pickup roller releasing spacer [2].</p> <p>Close the manual feed tray unit [3].</p>	 <p>F04-207-01</p>
2	<p>Open the right upper cover and the right lower cover, and push the release buttons of the front deck (right) and cassette 3/4; then, slide them halfway out.</p>	
3	<p>Remove the three pickup roller releasing spacers [1].</p> <p>Close the upper vertical path cover [2] and the lower vertical path cover [3].</p> <p>Fit the front deck (right) and the cassette 3/4 back in.</p>	 <p>F04-207-02</p>

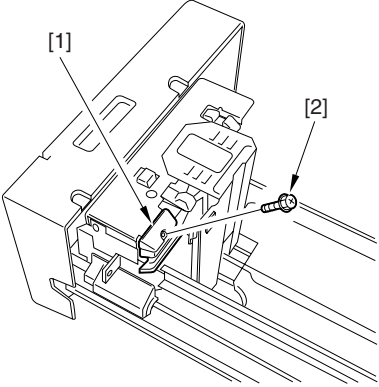

No.	Work	Checks/remarks
4	<p>Press the releasing button of the front deck (left), and slide it to the front.</p> <p>Secure the deck locking plate [1] to the front deck (left) with an RS tightening screw [2] (M4x10; white).</p> <p>Close the front deck (left).</p>	 <p>F04-207-03</p>

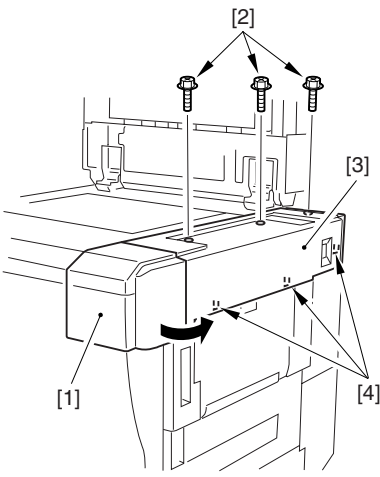
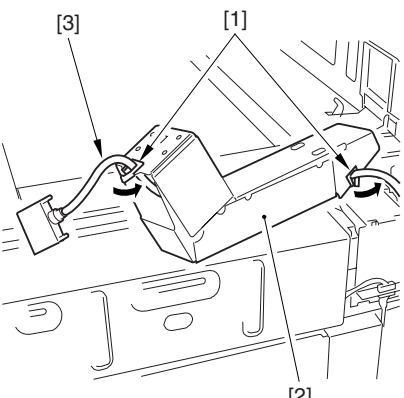
2.8 Mounting the Control Panel

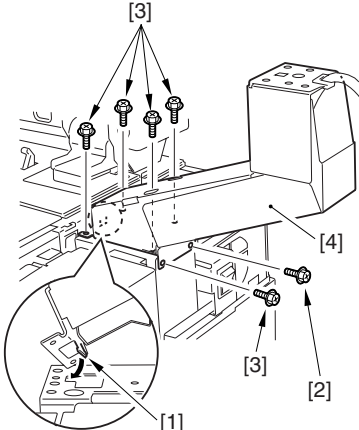
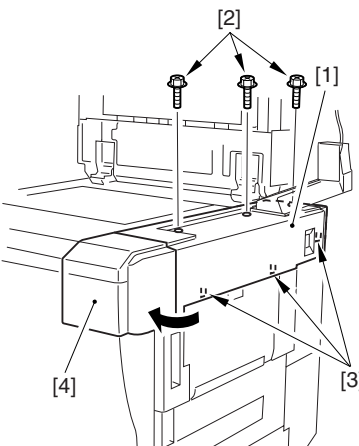
No.	Work	Checks/remarks
1	<p>Open the toner cartridge cover [1], and remove the 3 RS tightening screws [2]; then, detach the upper right cover [3] while paying attention to the three claws [4] found inside the upper right cover.</p> <p>When detaching it, be sure to lift the claw side of the upper right cover.</p>	 <p>F04-208-01</p>
2	<p>Open the 2 edge saddles [1] of the lower arm [2], and thread the control panel harness [3] through the lower arm. At this time, keep the control panel harness routed to the connector side so that it will not be slack.</p> <p>Close the 2 edge saddles.</p>	 <p>F04-208-02</p>

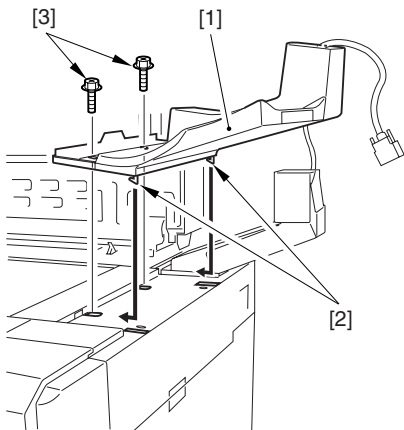
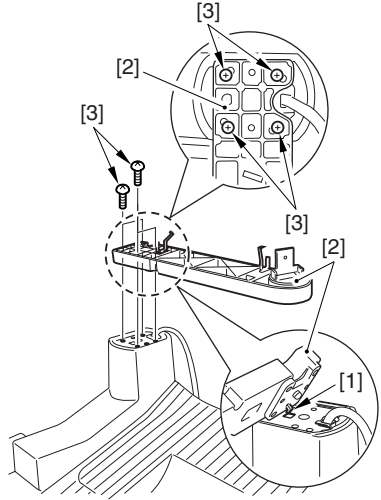
No.	Work	Checks/remarks
3	<p>Fit the claw [1] found at the bottom of the lower arm into the copier.</p> <p>Fit the RS tightening screw [2] (M4x10) of the right rear; after positioning, fit the remaining 5 RS tightening screws [3] (M4x10) to secure the lower arm [4].</p>	 <p>F04-208-03</p>
4	<p>Mount the upper right cover [1] with 3 RS tightening screws [2].</p> <p>At this time, check to make sure that the 3 claws [3] inside are fully engaged and the over is firmly in contact.</p> <p>Close the toner cartridge cover [4].</p>	 <p>F04-208-04</p>

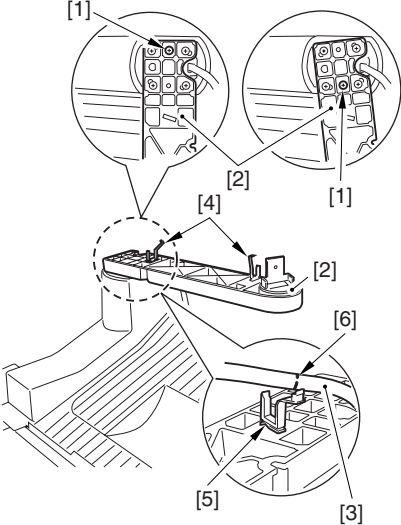
No.	Work	Checks/remarks
5	<p>Put the original delivery tray [1] over the lower arm, and hook the 2 claws [2] found at the bottom for the original delivery tray in the notches of the right upper cover; check that there is no gap, and then secure it in place with 2 RS tightening screws [3] (M4x10).</p>	 <p>F04-208-05</p>
6	<p>Hook the claw [1] of the upper arm [2] on the hole in the lower arm, and temporarily fix the upper arm in place with 4 binding screws [3] (M4x14).</p>	 <p>F04-208-06</p>

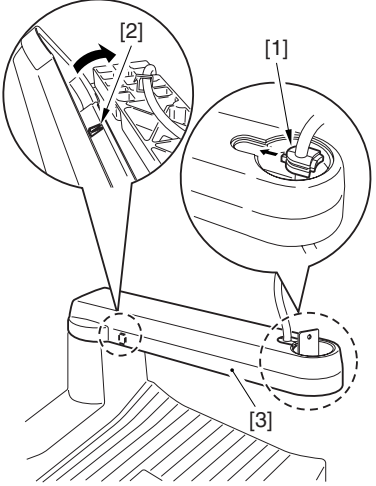
No.	Work	Checks/remarks
7	<p>Fit the positioning binding screw [1] (M4x14) so that the upper arm [2] is at the angle desired by the user; then, fully tighten the binding screw that was temporarily tightened.</p> <p>Lead the control panel harness [3] through the 2 wire saddles [4]. At this time, check to make sure that the wire saddle [5] at the rear matches the marking [6] on the control panel harness.</p>	 <p style="text-align: center;">F04-208-07</p>
8	<p>Pinch the control panel harness with a harness clip [1], and fit it to the upper arm.</p> <p>Hook the claw [2] found on the left side of the fate upper arm cover [3], and put it over the upper arm.</p> <div style="border: 1px solid black; padding: 5px; margin-top: 10px;"> <p> Keep the harness clip [1] so that the side with a protrusion (thicker side) is at the bottom.</p> <p>The harness clip [1] will separate into two during the work. Continue the work, as it will not affect its function.</p> </div>	 <p style="text-align: center;">F04-208-08</p>

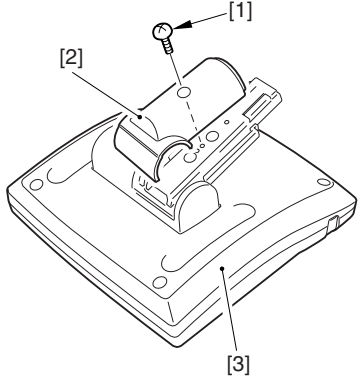
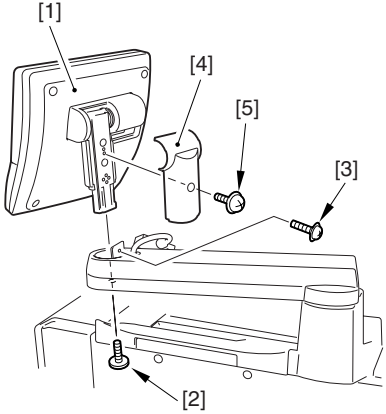
No.	Work	Checks/remarks
9	<p>Remove the binding screw [1], and detach the rear support cover [2] of the control panel unit [3].</p>	 <p>F04-208-09</p>
10	<p>Put the control panel unit [1] on the upper arm, and secure it in place with a flat-head screw [2] (M4x10) and a W sems screw [3] (M4x12). Mount the rear support cover [4] with a binding screw [5].</p>	 <p>F04-208-10</p>

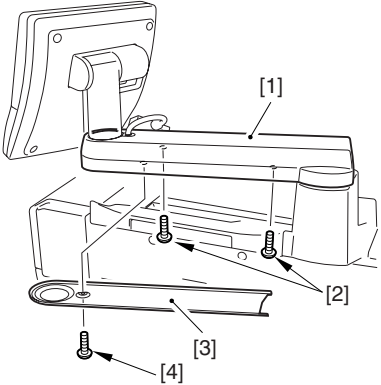
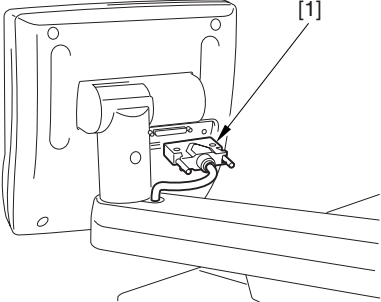
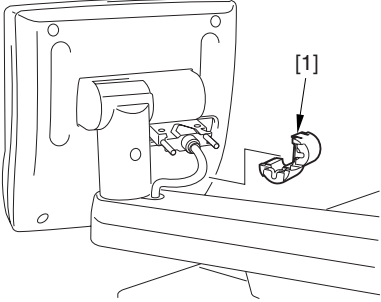
No.	Work	Checks/remarks
11	Secure the upper arm cover [1] with 2 P tightening screws [2] (M4x10). Mount the lower arm cover [3] with a binding screw [4] (M4x6).	 <p style="text-align: center;">F04-208-11</p>
12	Connect the connector [1] of the control panel harness to the control panel unit.	 <p style="text-align: center;">F04-208-12</p>
13	If for a 230V model, fit a ferrite core [1] to the control panel harness.	 <p style="text-align: center;">F04-208-13</p>

2.9 Supplying the Toner

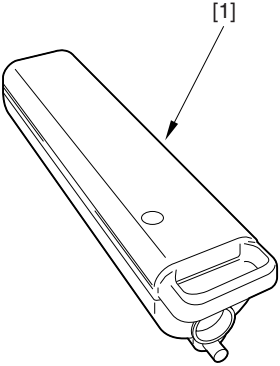
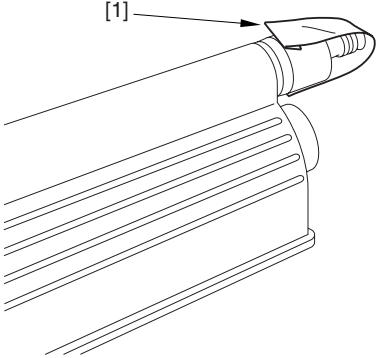
No.	Work	Checks/remarks
1	Take out the toner cartridge [1] for the packaging box.	 <p>F04-209-01</p>
2	Remove the fixing tape [1].	 <p>F04-209-02</p>

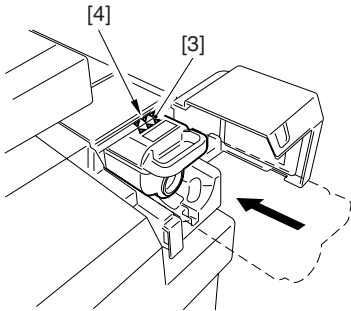
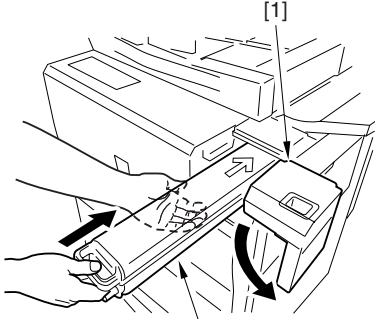
No.	Work	Checks/remarks
3	<p>Open the toner cartridge cover [1], and fit the toner cartridge [2] from the front of the copier.</p> <p> Be sure to insert the toner cartridge so that the ▲ marking [3] on it matches the ▼ marking [4] on the copier.</p>  <p style="text-align: center;">F04-209-03</p>	 <p style="text-align: center;">[2]</p> <p style="text-align: center;">F04-209-04</p>
4	Close the hoper cover.	

2.10 Mounting the ADF

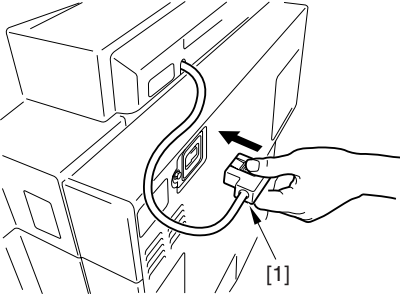
No.	Work	Checks/remarks
1	Remove the face plate for the ADF connector from the copier.	
2	Fit the ADF connector [1] into the socket found at the back of the copier.	 <p data-bbox="742 643 865 667">F04-210-01</p>

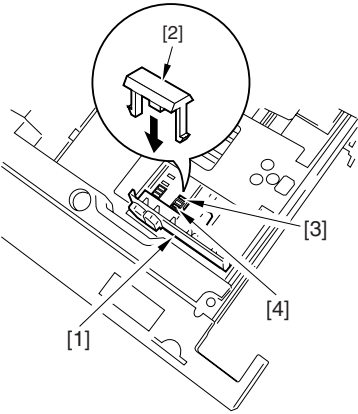

2.11 Cassette

No.	Work	Checks/remarks
1	<p> Perform this step if the user is not planning to use Inch papers.</p> <hr/> <p>Press the releasing buttons of the cassette 3 and 4, and slide out the cassettes to the front; then, take out the packing material.</p>	
2	<p>Set the side guide plate [1] of the cassette (3/4) against the hole (A4/A3) identified by the marking M.</p> <p>Fit the non-inch block [2] that comes with the machine into the following hole, making sure that it will not be pushed up from inside the cassette.</p> <p>Hole with marking A [3]: STMT-R Hole with marking H [4]: LTR-R</p>	 <p style="text-align: center;">F04-211-01</p>

2.12 Index Paper Attachment

No.	Work	Checks/remarks
1	<p>Decide on either cassette 3 or 4 for use for index paper.</p> <p>Press the releasing button for the cassette, and slide it out to the front.</p> <p>Peel the backing sheet [2] and the protective sheet [3] from the attachment sheet [1], and attach the attachment sheet to the area [4] indicated in the figure.</p>	<p style="text-align: center;">F04-212-01</p>
2	Place the index paper attachment [5] over the attachment sheet.	
3	<p>Fit the base sheet [6] in the cassette.</p> <p>Slid out the cassette.</p>	

2.13 Attaching the Labels, Setting Paper, Checking Images/ Operations, and User Mode

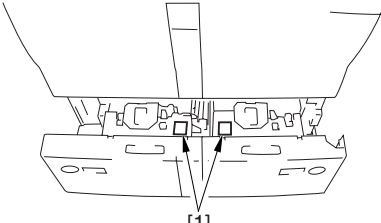
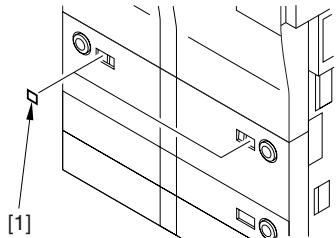
No.	Work	Checks/remarks
1	 <p>Check to make sure that the front deck and the cassette are free of any packing material.</p>	
2	<p>Connect the power plug to the power outlet, and turn on the main power switch.</p>	<ul style="list-style-type: none"> • Adjust the contrast of the control panel display using the Image Contrast dial for the best view, and advise the user on the use of the dial. • Check to see that the Add Paper message goes ON. • Press the keys on the keypad and the Clear key to see that the copy count is correctly indicated.
3	<p>Check with the user to decide on a paper size.</p>	
4	<p>Press the release button, and slide out the right/left deck.</p>	 <p>To change the size of the front deck (right/left), refer to 2.14.</p>
5	<p>Attach the 3-Hole Paper Set labels [1].</p>	 <p style="text-align: center;">[1] F04-213-01</p>
6	<p>Put paper in the right/left deck.</p>	
7	<p>Slide in the right /left deck, and attach the deck size labels [1] to the paper size plate of the deck.</p>	 <p style="text-align: center;">[1] F04-213-02</p>

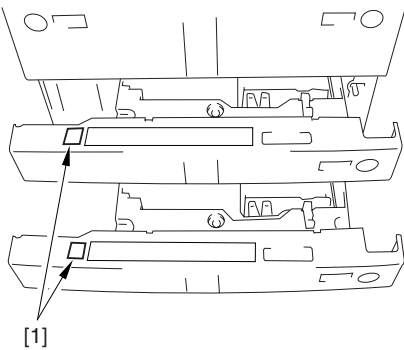
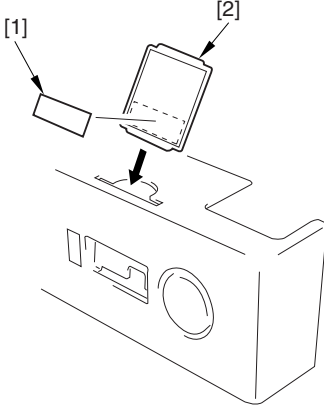
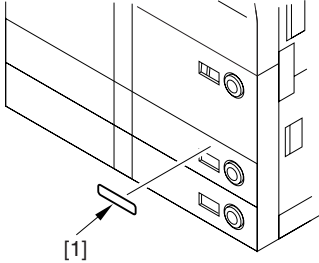
No.	Work	Checks/remarks
8	Press the release button, and slide out the cassette 3/4.	
9	Attach the 3-Hole Paper Set labels [1].	 <p style="text-align: center;">F04-213-03</p>
10	Attach the size label [1] to the paper size plate [2] of the cassette, and set it to the cassette cover.	 <p style="text-align: center;">F04-213-04</p>
11	Push in the cassettes into the copier.	FL cassette/W1 set
12	Attach the universal cassette label [1] to the cassette to suit the user's needs.	 <p style="text-align: center;">F04-213-05</p>

No.	Work	Checks/remarks
13	<p>Start service mode.</p> <p>Make the following selections: COPIER>FUNCTION>INSTALL>TONER-S.</p> <p style="text-align: center;">↓</p> <p>See that the following message has appeared: 'Check the Developer'.</p> <p style="text-align: center;">↓</p> <p>Check to see that the developing assembly and the developing assembly locking plate are correctly mounted; then, press the OK key.</p> <p style="text-align: center;">↓</p> <p>The machine starts to supply toner. (about 10 min; progress shown on display by count-down)</p> <p style="text-align: center;">↓</p> <p>At the end, make the following selections to generate 2 A3 solid black copies to ensure stable images: COPIER>TEST>PG>PG_PICK.</p> <p style="text-align: center;">↓</p> <p>Enter the number of the source of paper containing A3 paper, and press the OK key. ('3' for cassette 3, or '4' for cassette 4)</p> <p style="text-align: center;">↓</p> <p>Make the following selections: COPIER>TEST>PG>TYPE.</p> <p style="text-align: center;">↓</p> <p>Enter '6', and press the OK key. ('6' for solid black; PG-TYPE6)</p> <p style="text-align: center;">↓</p> <p>Preset the Start key twice to generate 2 solid black copies (A3).</p> <p style="text-align: center;">↓</p> <p>At the end, press the Reset key twice to end service mode.</p>	<p>Starting Service mode</p> <ol style="list-style-type: none"> 1) Press the User Mode key. 2) Press the '2' and '8' keys at the same time on the keypad. 3) Press the User Mode key. <div style="border: 1px solid black; padding: 5px; margin-top: 10px;">  <p>Never turn off the power while the machine is in operation.</p> </div>

No.	Work	Checks/remarks
14	<p>Place the Test Sheet on the copyboard glass, and check the copy image.</p> <p>Check to make sure that pickup from each source of paper is normal. (Make 3 test copies each from the decks and the cassettes.)</p> <div style="display: flex; align-items: center;">  <div style="border: 1px solid black; padding: 5px; width: fit-content;"> <p>The first 10 copies or so may show soiled images because of toner dropping from the drum separation claw. This symptom will disappear as more and more copies are made.</p> </div> </div>	<ul style="list-style-type: none"> • Check to make sure that there is no abnormal noise. • Check the quality of copy images for each default ratio. • Check to make sure that as many copies as set are made. • Check to make sure that copying operation is normal. • If there is a difference in density between left and right, adjust the height of the rear of the primary charging assembly.
15	Make double-sided copies, and check the operation.	
16	Make user mode and service mode settings to suit the needs of the user.	
17	Press the Rest key twice to end service mode.	
18	Clean up the area around the copier.	
19	Move the copier to its final location, and secure it in place using the adjusters.	
20	If you are installing accessories, do so by referring to the Installation Procedure that comes with each accessory.	For the Card Reader-D1, see 4.1 “Installing the Card Reader-D1.”
21	Fill out the Service Sheet.	

2.14 Changing the Paper Size for the Front Deck (right, left)

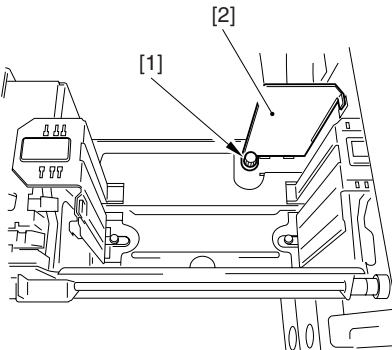
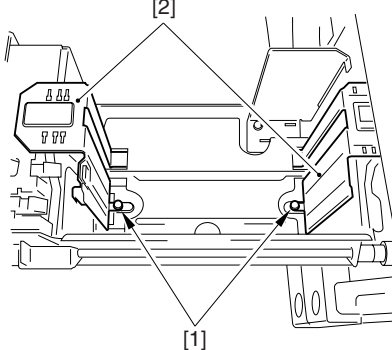
No.	Work	Checks/remarks
1	Press the release button, and slide out the deck.	
2	Remove the screw [1] of the rear end guide plate [2], and secure the guide plate [2] to the desired position.	 <p style="text-align: center;">F04-214-01</p>
3	Remove the screw [1] (1 pc. each) from the left and right of the guide plate [2], and secure the guide plate [2] to the desired position.	 <p style="text-align: center;">F04-214-02</p>
4	Put paper in the deck.	
5	Slide the deck inside the copier.	

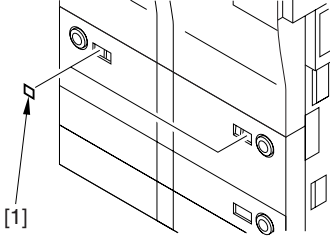
No.	Work	Checks/remarks
6	Attach the new Deck Size labels [1] to the paper size plate of the deck.	 <p style="text-align: center;">F04-214-03</p>
7	Start service mode, and register the paper size of the front deck. Thereafter, turn off and then on the main power switch.	Right deck : COPIER>OPTION>CST>P-SZ-C1 Left deck : COPIER>OPTION>CST>P-SZ-C2 A4=6 (200V model default), B5=15, LTR=18

3 Relocating the Machine

After installation, if the machine must be relocated by truck or other means of transportation, perform the following:

No.	Work	Checks	Remarks
1	Make a copy in Direct.		
2	Take out all paper from all cassette.		
3	Turn off the power switch, and disconnect the power plug from the power outlet.		
4	Fix the No. 2 mirror base in place from the left cover side with scanner fixing.	Check to make sure that the No. 2 mirror base does not move.	
5	Take out the developing assembly.	Carry the developing assembly in a separate box.	
6	Tape the transfer charging assembly, fixing/feeding assembly, releasing lever, and lower feeding assembly in place to protect them against vibration.		
7	Tape the front door, hopper cover, cassettes, and right door (upper, lower) in place.		
8	Place A3 copy paper on the copyboard glass, and tape the ADF in place.		



-
- A. If stairs are used to move the copier into or out of the user's place, keep the following in mind:
1. Take out the fixing/feeding assembly, holding tray, and copy paper from the copier, and carry them separately. (If an ADF is installed, remove it also.)
 2. When lifting the copier, do not use the grips on the pickup/delivery assembly; instead, support it at four corners of the machine bottom.
- B. Shift up the 2 adjusters (front) found on the bottom of the copier, and check to make sure that they are unlocked. Take care, as the adjusters can slip out of the machine because of vibration while in transit.
- C. Be sure to remove the accessories (side paper deck, finisher) when moving the copier into or out of the user's place.
-

4 Installing the Card Reader-D1

4.1 Installing the Card Reader-D1

Install the Card Reader-D1 as follows:

No.	Work	Checks/remarks
1	Start service mode (COPIER>FUNCTION>INSTALL>CARD), and enter the lowest card number (from 1 to 2001). As many as 1000 cards, starting with the number, may be used.	
2	Turn off the main power switch of the copier, and disconnect the power plug.	
3	Open the front cover.	
4	Remove the screw [1], and detach the primary charging assembly front cover [2].	<p>The diagram shows a perspective view of the copier's internal components. A screw, labeled [1], is shown being removed from the front cover of the primary charging assembly. The front cover itself is labeled [2]. The diagram is identified by the code F04-401-01.</p> <p style="text-align: center;">F04-401-01</p>

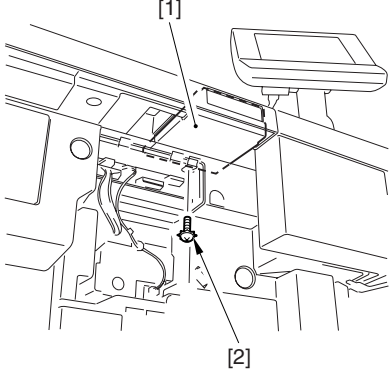
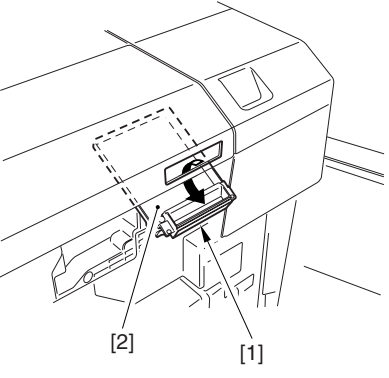
No.	Work	Checks/remarks
5	<p>While supporting the card reader base [1], remove the screw (w/ washer) [2]. (You will need the screw and the washer later.)</p>	 <p>F04-401-02</p>
6	<p>Push in the face plate [1] lightly, and take out the card reader base assembly [2] from below.</p>	 <p>F04-401-03</p>

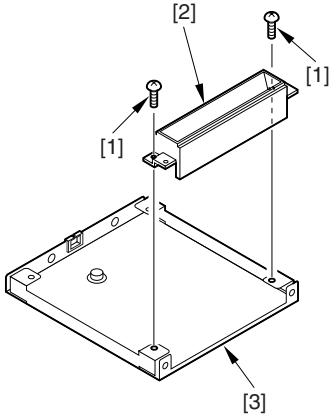
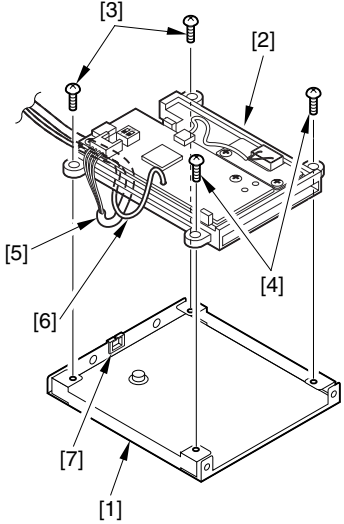
No.	Work	Checks/remarks
7	<p>Remove the 2 screws [1], and detach the face plate [2] from the card reader base assembly [3]. (You will use the removed parts later.)</p>	 <p style="text-align: center;">F04-401-04</p>
8	<p>Remove the 2 screws that remain on the top of the card reader [1].</p> <p>Mount the card reader [2] using the 2 removed screws [3] and the 2 screws [4] used to keep the face plate in place. (At this time, be sure to route the harness [5] and the grounding wire [6] under the card reader as indicated.)</p> <p>Route the harness through the edge saddle [7].</p>	 <p style="text-align: center;">F04-401-05</p>

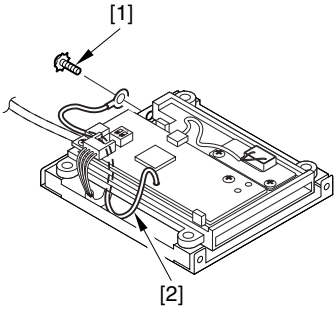
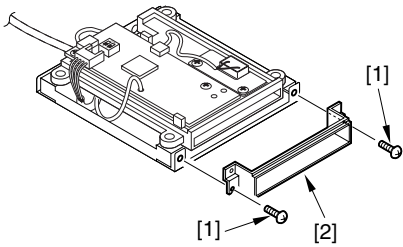
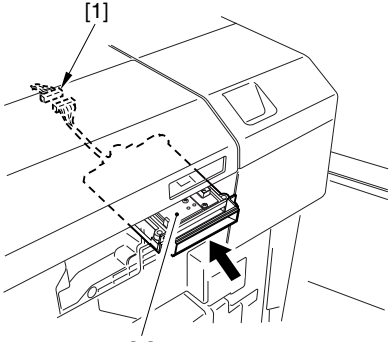
No.	Work	Checks/remarks
9	<p>Remove the screw (w/washer) [1] from the rear of the card reader base.</p> <p>Secure the grounding wire [2] with the removed screw (w/ washer) [1].</p>	 <p>F04-401-06</p>
10	<p>Remove the 2 screws [1] from the front of the card reader base.</p> <p>Secure the face plate [2] removed in step 4 with 2 screws [1] as shown.</p>	 <p>F04-401-07</p>
11	<p>Connect the connector [1] of the copier and the harness of the card reader to which a relay post heater is attached.</p> <p>Push the harness into the copier, and fit in the card reader assembly [2].</p>	 <p>F04-401-08</p>

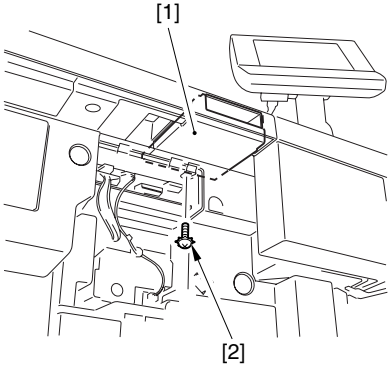
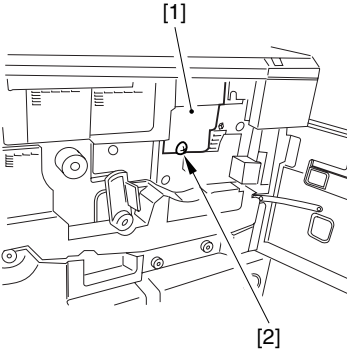
No.	Work	Checks/remarks
12	While supporting it, mount the card reader assembly [1] with the screw (w/ washer) [2] removed in step 5.	 <p style="text-align: center;">F04-401-09</p>
13	Mount the primary charging assembly front cover [1] with a screw [2].	 <p style="text-align: center;">F04-401-10</p>
14	Close the front cover.	
15	Connect the power plug of the copier, and turn on the main power switch.	

5 Installing the NE Controller-A1/NE Controller-B1/ Copy Data Controller-A1

5.1 Installing the NE Controller-A1/NE Controller-B1/Copy Data Controller-A1

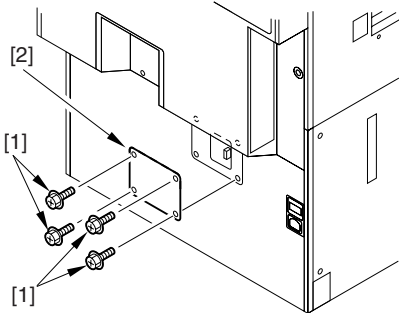

Here, the instructions are limited to installation to an iR105. For how to make various settings, checks to make, and points to note, see the Installation Procedure that comes with a specific controller.

No.	Work	Checks/remarks
1	<p>Remove the 4 screws [1] that come with the rear cover of the host machine, and remove the face cover [2].</p> <div style="border: 1px solid black; padding: 5px; margin-top: 10px;">  <p>If you are installing a Copy Data Controller-A1 to a 230V machine, go to step 4.</p> </div>	 <p style="text-align: center;">F04-501-01</p>

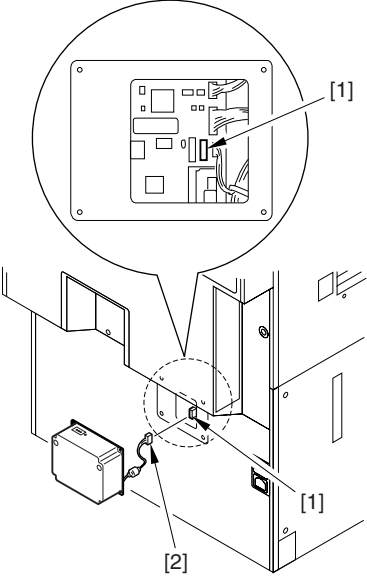
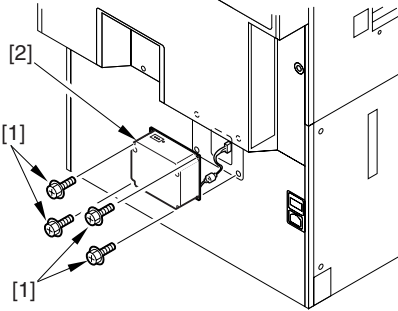
No.	Work	Checks/remarks
2	Connect the connector J525 [1] of the host machine with the cable [3] of the controller.	 <p>F04-501-02</p>
3	Mount the controller [2] with 4 screws [1].	 <p>F04-501-03</p>

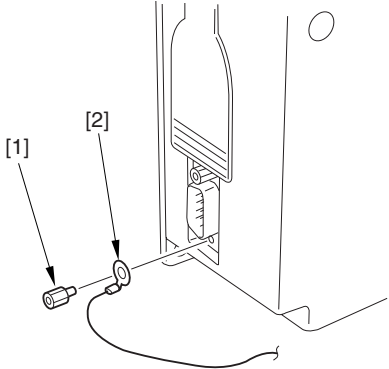
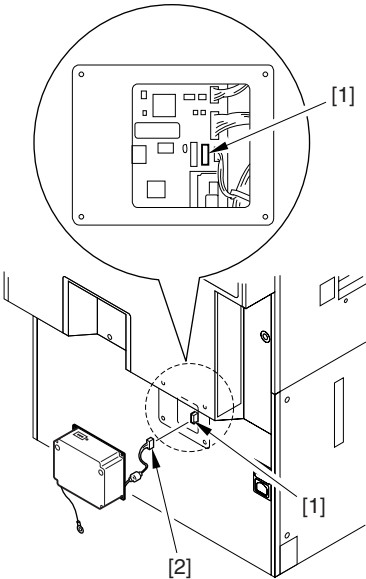
No.	Work	Checks/remarks
4	<p>[When Installing a Copy Data Controller-A1 to a 230V Model]</p> <p>Remove the connector fixing screw (bottom) [1].</p> <p>Bend the terminal of the grounding wire [2] that comes with the machine to the outside, and mount it using a connector fixing screw [1].</p>	 <p>F04-501-04</p>
5	<p>Connect the connector J525 [1] of the host machine and the cable [3] of the controller.</p>	 <p>F04-501-05</p>

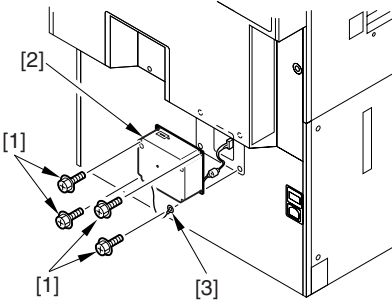
No.	Work	Checks/remarks
6	<p>Mount the controller [2] using 4 screws. At this time, be sure to tighten the other terminal [3] of the grounding wire using the right lower screw.</p>	 <p>F04-501-06</p>

CHAPTER 5

MAINTENANCE AND INSPECTION

1 Periodically Replaced Parts

Some parts of the machine must be replaced on a periodical basis to ensure a specific level of product performance; once they fail, the consequences will be appreciable.

If possible, plan the replacement to coincide with a scheduled visit.

As of May 2001

No.	Parts name	Parts No.	Q'ty	Life (pages)	Remarks
1	Pre-transfer/transfer/separation charging wire	FB4-3687-000	AR	500,000*	If high temperature/humidity, every 250,000 pages.
	Primary charging wire	FB4-3687	AR	500,000*	If high temperature/humidity, every 250,000 pages. If normal temperature/low humidity, every 400,000 pages.
2	Primary grid wire	FY1-0883-000	AR	500,000	
3	Main thermistor	FG6-7748	1	500,000	
4	Sub thermistor	FH7-7464-000	1	500,000	
5	Thermal switch unit	FG6-7745-000	1	1,000,000	
6	Ozone filter (drum)	FB6-0776-000	1	1,000,000	
7	Ozone filter (separation)	FB6-0397-000	1	1,000,000	
8	Ozone filter (fixing)	FB6-0403-000	1	1,000,000	

Note: The above figures are estimates only, and are subject to change based on future data.

* Older type (full-plated) must not be used.

After replacing the charging wire, be sure to execute wire cleaning in service mode:
COPIER>FUNCTION>CLEANING>WIRE-CLN.

* After servicing the charging assembly, be sure to mount it back while moving the cleaning holder toward the front.

T05-100-01

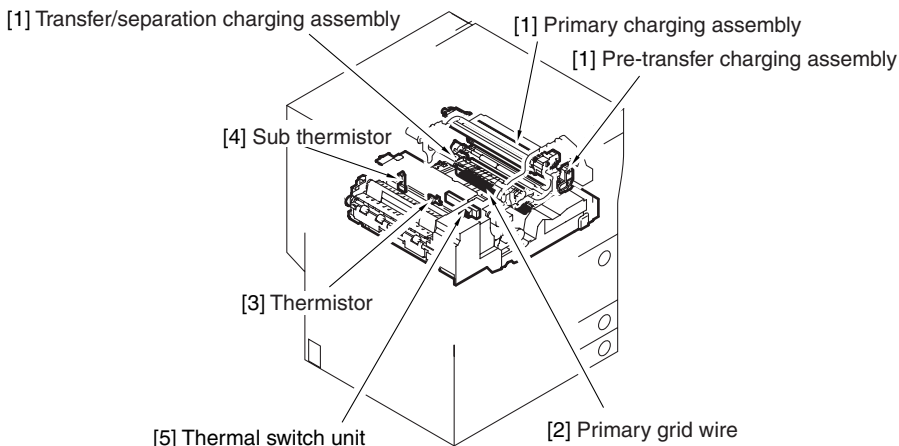

F05-100-01

2 Guide to Replacement of Durables

Some parts of the machine may prove to require replacement once or more over the period of product warranty because of wear or damage. Replace them when they fail; see the following for a guide:

2.1 Copier

As of May 2001

No.	Parts name	Parts No.	Q'ty	Life (pages)	Remarks
1	Scanning lamp	FH7-3347	1	200 hr or 150,000 activa- tions	Check in service mode: ■Period of Activation COPIER>COUNTER> DRBL-1>SCN- LMP ■Number of Activations COPIER>DISPLAY> MISC>SCAN-LMP
2	Developing cylinder	FB6-2370	1	1,000,000	
3	Developing assembly roll	FS5-6579	2	1,000,000	
4	Cleaner separation claw	FB4-8018	3	500,000	
5	Cleaning blade	FB6-2720	1	1,000,000	Use both edges, each for 500,000 pages; apply toner upon re- placement.
6	Primary charging assembly	FG6-7313	1	1,000,000	
7	Transfer/separation charging assembly	FG6-8733	1	1,000,000	
8	Pre-transfer charging assem- bly	FG6-7424	1	1,000,000	
9	Primary charging wire cleaner 1	FF5-6883	2	500,000	If high temperature/ humidity, every 250,000 pages.
10	Primary charging wire cleaner 2	FF5-6884	2	500,000	If high temperature/ humidity, every 250,000 pages.
11	Transfer charging wire cleaner 1	FF5-6883	1	500,000	
12	Transfer charging wire cleaner 2	FF5-6884	1	500,000	
13	Separation charging wire cleaner	FF5-7891	1	500,000	

T05-201-01

CHAPTER 5 MAINTENANCE AND INSPECTION

No.	Parts name	Parts No.	Q'ty	Life (pages)	Remarks
14	Pre-transfer charging wire cleaner	FF5-9552	1	500,000	
15	Pre-transfer charging assembly scraper	FF6-1031	1	500,000	
16	Fixing upper roller	FB5-6930	1	500,000	
17	Fixing lower roller	FB5-6952	1	500,000	
18	Fixing web	FY1-1157	1	500,000	
19	Insulating bush (front/rear)	FB5-6934	2	500,000	Replace together with fixing upper roller.
20	Fixing roller bearing	XG9-0421	2	1,000,000	
21	Fixing pressure roller bearing	XG9-0447	2	1,000,000	
22	Delivery upper separation claw	FB5-3625	6	500,000	
23	Delivery lower separation claw	FA2-9037	2	1,000,000	
24	Pickup roller (deck, cassette)	FF5-7829 (front) FF5-7830 (rear)	8	500,000	Actual number of pages (2 pc. each). Number may be checked in service mode*: left deck: LD-PU-RL right deck: RD-PU-RL cassette 3: C3-PU-RL cassette 4: C4-PU-RL
25	Delivery roller (deck, cassette)	FB6-0615	8	500,000	Actual number of pages (2 pc. each). Number may be checked in service mode*: left deck: LD-FD-RL right deck: RD-FD-RL cassette 3: C3-FD-RL cassette 4: C4-FD-RL

* COPIER>COUNTER>DRBL-1.

T05-201-02

No.	Parts name	Parts No.	Q'ty	Life (pages)	Remarks
26	Separation roller (deck, cassette)	FB5-6586	4	500,000	Actual number of pages processed. (1 pc. for each holder) May be checked in service mode*: left deck: LD-SP-RL right deck: RD-SP-RL cassette 3: C3-SP-RL cassette 4: C4-SP-RL
27	Pickup roller (manual feed tray)	FF9-1763 (front) FF9-1764 (rear)	2	120,000	Actual number of pages processed. May be checked in service mode*: M-UP-RL
28	Feed roller (manual feed tray)	FB4-2035	2	120,000	Actual number of pages processed. May be checked in service mode*: MM-FD-RL
29	Separation roller (manual feed tray)	FB2-7545	1	120,000	Actual number of pages processed. May be checked in service mode*: M-SP-RL
30	Cleaner side scraper (font)	FB5-6868	1	1,000,000	
31	Cleaner side scarper (rear)	FB5-6869	1	1,000,000	

* COPIER>COUNTER>DRBL-1.

T05-201-03

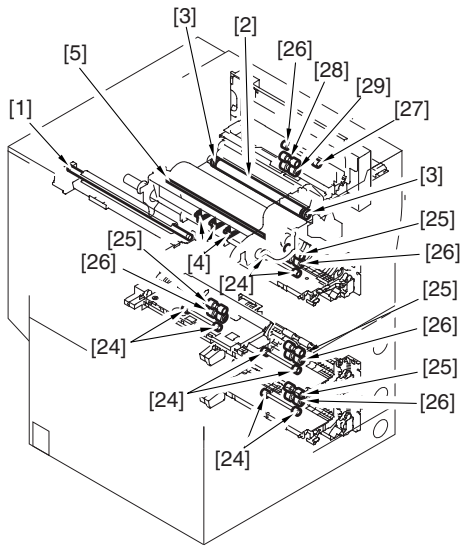

F05-201-01

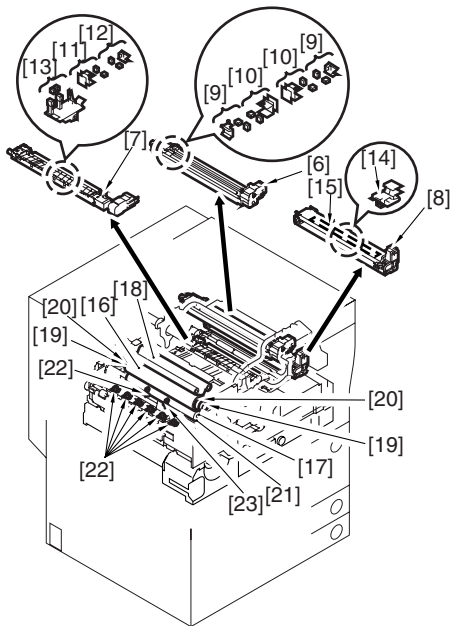

F05-201-02

2.2 Side Paper Deck

No.	Parts name	Parts No.	Q'ty	Life (pages)	Remarks
1	Side Paper Deck Feed Roller	FF5-7829 (front) FF5-7830 (rear)	2	500,000	As of May 2001 Actual number may be checked in service mode.* PD-PU-RL
2	Side Paper Deck Delivery Roller	FB6-0615	2	500,000	Actual number may be checked in service mode.* PD-FD-RL
3	Side Paper Deck Separation Roller	FB5-6586	1	500,000	Actual number may be checked in service mode.* PD-SP-RL

* COPIER>COUNTER>DRBL-2.

T05-202-01

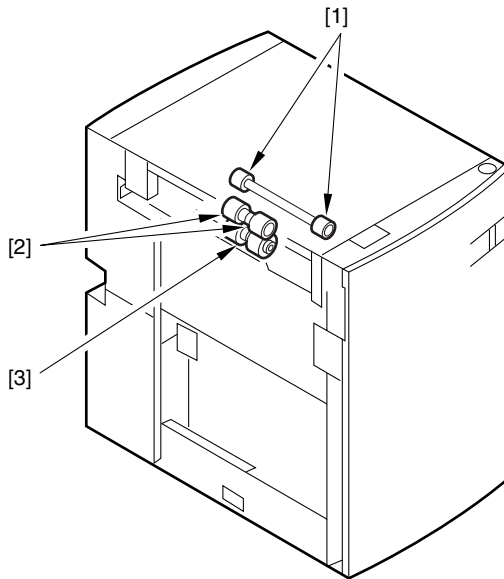

F05-202-01

3 Scheduled Service Chart



1. As a rule, provide scheduled service every 500,000 copies.
2. Check the Service Book before setting out for a visit, and take parts expected to require replacement.
3. If you have cleaned a charging wire with alcohol, check to be sure that the solvent has dried before mounting it back to the machine.
4. If the power plug is left connected for a long time in an area subject to excessive dust, humidity, or smoke (containing oil vapor), an insulation fault and, ultimately, a fire can occur (owing to the build-up of moist dust.)
Be sure to disconnect the power plug on a periodical basis, and wipe the area and the power plug clean with a dry cloth.

As of May 2001

No.	Work	Checks	Remarks
1	Meet the person in charge.	Check the general condition.	
2	Record the counter readings.	Check the faulty copies.	
3	Make test copies.	a. Image density b. Soiled background c. Character clarity d. Leading edge margin e. Fixing, displaced registration, soiled back	Standards (single-sided) Leading edge: 4.0+1.5, -1.0 mm Left/right: 2.5±1.5 mm Trailing edge: 2.5±1.5 mm
4	Clean the charging assemblies: <ul style="list-style-type: none"> • Charging wire (primary, pre-transfer, transfer/separation) • Grid wire (primary charging assembly) • Shielding plate (charging assembly) • Roller electrode 		Dry wipe with lint-free paper, and clean with alcohol.

T05-300-01



Points to Note When Cleaning/Replacing the Charging Wire or Replacing the Charging Wire Cleaner

At the end of the following work, check to be sure that the charging wire is in the middle of the charging wire cleaner; otherwise, image faults can occur:

- a. Cleaning the charging wire.
- b. Replacing the charging wire.
- c. Moving the charging wire cleaner by hand.
- d. Replacing the charging wire cleaner.

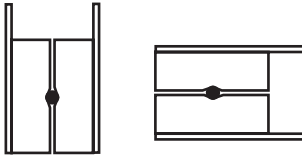

Correct

F05-300-01

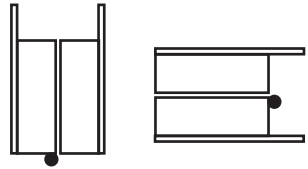



Wrong

F05-300-02

No.	Work	Checks	Remarks
5	Clean the optical assembly: <ul style="list-style-type: none"> • No. 1/2/3 mirror • Dust-proof glass • Reflecting plate • Standard white plate 		Clean with a blower brush; if dirt cannot be removed, use alcohol.
6	Check the scanner system: <ul style="list-style-type: none"> • Scanner cable • Scanner rail 	Check the tension of the cable. Clean the sliding areas, and apply silicone oil (FY9-6011).	Check the scanner cable only after making the first 250,000 pages.
7	Check the waste toner case.	If the case is more than half full, dispose of the toner in a plastic bag. Or, replace the case.	
8	Clean the filters: <ul style="list-style-type: none"> • Ozone filter • Dust-proof filter 		Remove the dust from the filter surface.
9	Clean the developing assembly: <ul style="list-style-type: none"> • Developing assembly roll 	Clean the developing assembly roll.	
10	Clean the pickup feeding assembly: <ul style="list-style-type: none"> • Transfer guide (upper, lower) plate • Registration roller (upper, lower) • Feeding belt • Feeding rollers • Scanner sensor cleaning (prism) 		Clean with an air blower or dry wipe. (Do not use solvent.)
11	Clean the fixing/delivery assembly: <ul style="list-style-type: none"> • Separation claw (upper, lower) • Feed rollers • Inlet guide • Web (check) • Web oil receptacle • Thermistor • Sub thermistor • Thermal switch 		

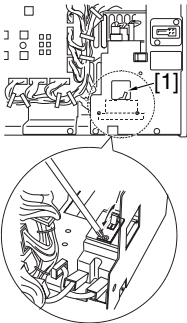
T05-300-02

No.	Work	Checks	Remarks
12	Clean the cleaner assembly: • Side scraper		
13	Clean the duplex assembly: • Duplex horizontal registration sensor		
14	Clean the copyboard glass.		
15	Make test copies.		
16	Make sample copies.		
17	Press the leakage breaker test switch to make sure that it operates normally. Thereafter, turn off the power switch, and shift the lever to the ON side; then, turn on the power switch.	With the power switch set to ON and, in addition, the lever [1] of the leakage breaker in ON state, press the test switch. If normal, the lever should flip to the OFF side, cutting the power. (Pay attention to its orientation when replacing it.) If you have replaced the leakage breaker, be sure to make this check.	 <p>F05-300-03</p>
	 <p>Check to make sure that the grounding is correct. Otherwise, possible leakage will not turn on the leakage breaker.</p>		
18	Put the sample copies into order, and clean up the area around the machine.		
19	Record the last counter readings.		
20	Fill out the Service Book, and report to the person in charge.	Be user to describe the check on the leakage breaker in the Service Book.	

T05-300-03

4 Scheduled Service Items



Do not use solvents or oils not indicated herein.

4.1 Copier

△: Clean ●: Replace ×: Lubricate □: Adjust ◎: Check

Unit	Location	Service interval			Remarks
		installa- tion	every 500,000	every 1,000,000	
Externals and con- trols	Copyboard glass		△		
	Ozone filter (FM2, FM8, FM19)		△	●	Remove dust from the filter surface. See F05-401-01.
	Dust filter (FM1 (2 pc.), FM3, FM10, front cover, upper front cover)		△		Remove dust from the filter surface. See F05-401-01.
Scanner system	Scanner wire		◎□		Check only at initial 500,000 pages.
	Scanner rail		△×		Use silicone oil S-20 (FY9-6011)
Optical system	No. 1 to No. 3 mir- rors		△		
	Dust-proof glass		△		
	Reflecting plate		△		
	Standard white plate		△		
	Pre-transfer expo- sure LED	△		●	

T05-401-01

Unit	Location	Service interval			Remarks
		installa- tion	every 500,000	every 1,000,000	
Charging assembly	Charging wire (primary)	△	●		If high temperature/humid- ity, every 250,000 pages.
	Charging wire (transfer/separa- tion)	△	●		If high temperature/humid- ity, every 250,000 pages.
	Charging wire (Pre- transfer)	△	●		If high temperature/humid- ity, every 250,000 pages. If normal temperature/low humidity, every 400,000 pages.
	Grid wire (primary)	△	●		
	Charging assembly shielding plate	△	△		If high temperature/humid- ity, every 250,000, pages.
	Electrode	△	△		If high temperature/humid- ity, every 250,000 pages.
Photo- sensitive drum	Photosensitive drum		△		Clean with alcohol and drum cleaning powder (CK- 0429). For instructions, see 4.2>4.2.2 work 2.
	Electrode for stop ring (drum heater)			△ ×	Clean the following with alcohol; then, apply FY9- 67008 to the dust-collecting brush: • Electrode of slip spring • Wall surface of protrusion (electrode) • Dust-collection brush
Develop- ing as- sembly	Developing cylin- der	◎			
	Developing roll		△		
Cleaner	Side scraper		△		For instructions, see 4.2>4.2.1 work 1.
	Toner receptacle (rear/front)		△		For instructions, see 4.2>4.2.1 work 1.
	Magnet roller		△		For instructions, see 4.2>4.2.2>work 2.

T05-401-02

Unit	Location	Service interval			Remarks
		installa- tion	every 500,000	every 1,000,000	
Fixing assembly	Inlet guide		△		
	Web	◎			
	Oil receptacle		△		
	Thermistor		●		
	Sub thermistor		●		
	Thermal switch			●	
Scanner sensor	Sensor		△		If high temperature/humid- ity, every 250,000 pages.
	Prism		△		If high temperature/humid- ity, every 250,000 pages.
Waste toner collect- ing as- sembly	Waste toner case		◎		Check and dispose of the toner as necessary.
Pickup/ feeding assembly	Transfer guide		△		
	Registration roller (upper, lower)		△		
	Feeding belt		△		
	Feeding rollers		△		
Duplex assembly	Duplex horizontal registration sensor		△		
	Duplex roller		△		

T05-401-03

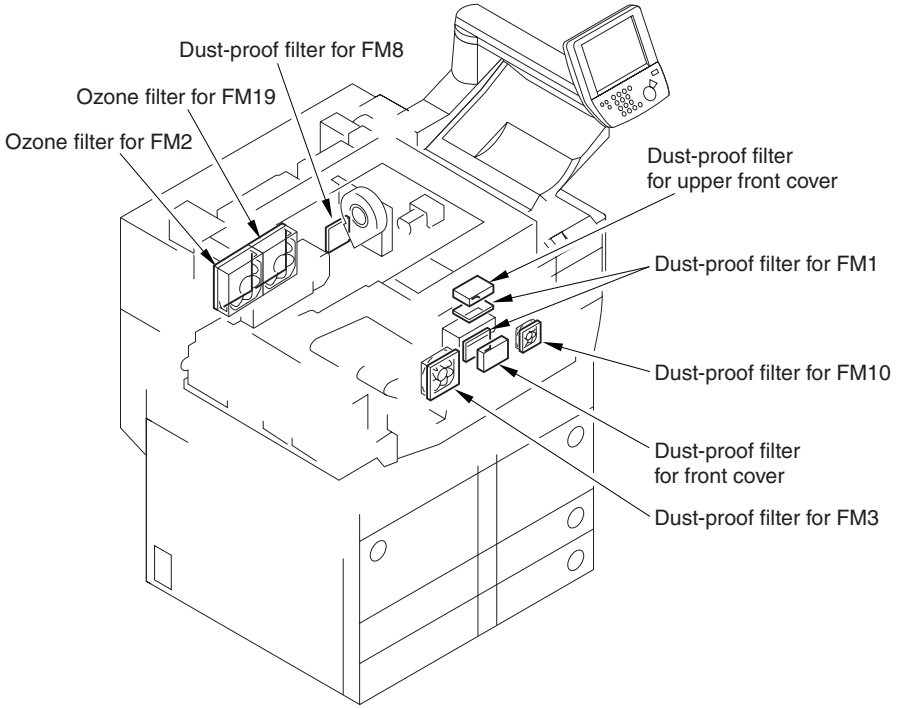

F05-401-01

4.2 Scheduled Service Work

Perform the following when maintaining the area around the drum as part of scheduled service work:

4.2.1 Work 1

- a. Cleaning the side scraper assembly
- b. Cleaning the toner receptacle



During the work, take care not to rotate the magnet roller drive assembly. Otherwise, waste toner will drop from the cleaner assembly.

- 1) Slide out the process unit. (See 5.8.1 in Chapter 2.)



Be sure to place a protective sheet over the fixing/feeder unit.

- 2) Take out the photosensitive drum.
- 3) Take out the cleaner blade assembly.
- 4) While keeping the magnet roller [1] and the scraper [2] at the front, move the build-up of waste toner with a piece of paper [3] or the like toward the feedscrew rear.

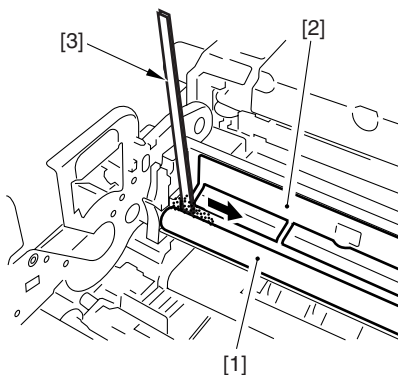

F05-402-01

- 5) Release the locks [1] of the slide rail, and draw the fixing/feeding unit [2] farthr to the front.

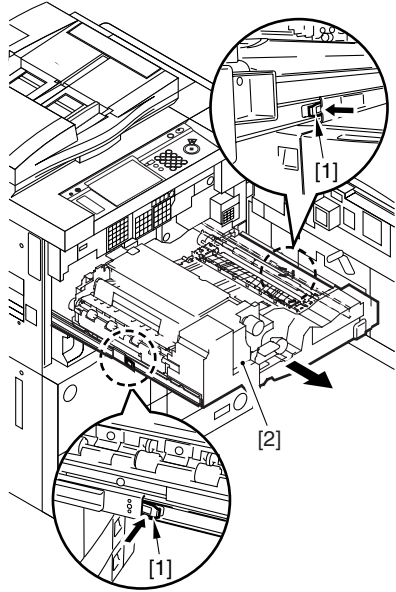

F05-402-02

- 6) With the cleaner assembly [1] halfway slid put, remove the screw [2] (1 each), and detach the two toner receptacle fixing plates [3].
- 7) Remove the front toner receptacle, and remove the toner from the front toner receptacle [4].

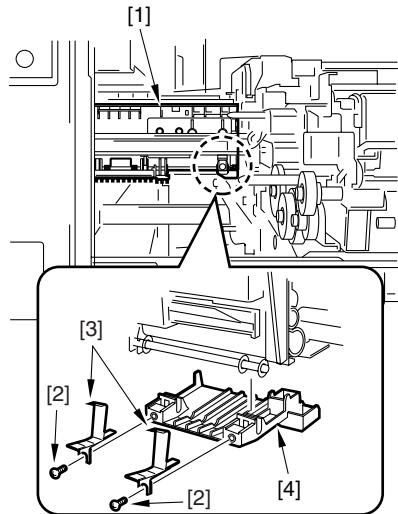

F05-402-03

- 8) Slide out the cleaner assembly [1], and remove the screw [2] (1 each); then, detach the two toner receptacle fixing plates [3].
- 9) Remove the rear toner receptacle, and remove the toner from the rear toner receptacle [4].

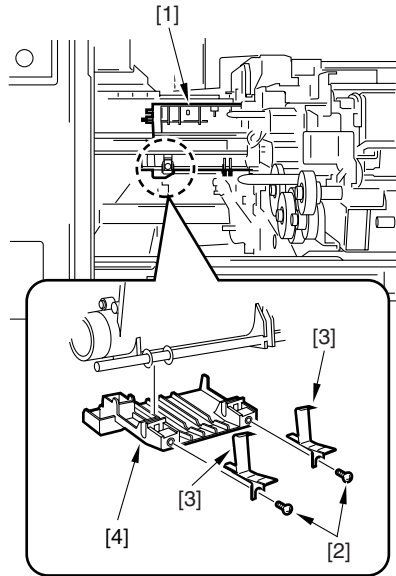

F05-402-04

4.2.2 Work 2

- a. Cleaning the photosensitive drum
- b. Removing the toner from the magnet roller assembly
- c. Turning over or replacing the cleaner blade



During the work, take care not to turn the magnet roller drive assembly. Otherwise, waste toner can drop from the cleaner assembly.

- 1) Slide out the process unit. (See 5.7.1 in Chapter 2.)



Be sure to place a drum protective sheet over the fixing/feeding unit.

- 2) Remove the photosensitive drum.
- 3) Moisten lint-free paper [1] with 5 to 10 cc of alcohol [2], and collect 0.2 to 0.3 g of drum cleaning powder (CK-0429) [3] with the lint-free paper.

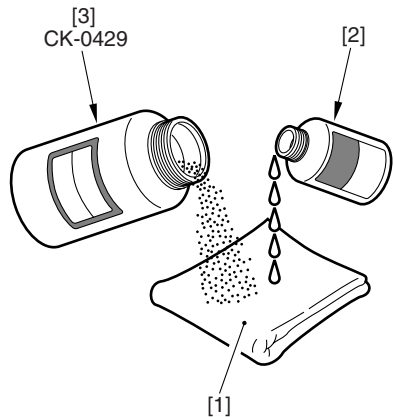

F05-402-05

- 4) While forcing the lint-free paper against the photosensitive drum, wipe the drum as if to rub it from the front to the rear and then from the rear to the front with force.



- Clean the drum in widths of 5 to 10 cm in peripheral direction.
- For a single width, you may force the lint-free paper back and forth 15 to 20 times without damaging the drum.

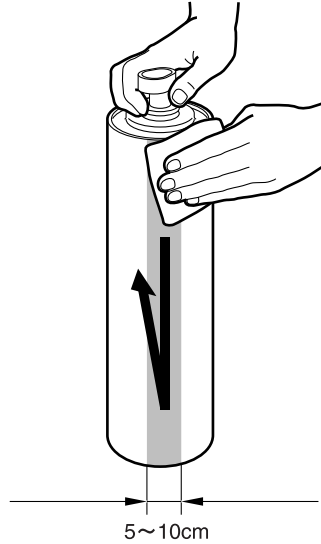

F05-402-06

- 5) Wait until the alcohol has evaporated; then, dry wipe the drum with lint-free paper. If traces remain, repeat step 4) and increase the number of trips made.
- 6) Rotate the drum so that that new areas may be cleaned (5 to 10 cm). Repeat steps 3) to 5) until the entire surface of the drum has been cleaned.
- 7) Remove the cleaning blade assembly.

- 8) Insert a ruler [3] between the magnet roller [1] and the scraper [2]; then, move it from the front to the rear and then from the rear to the front to break the caking toner.
- 9) Turn the magnet roller [1] to make sure that the coating of waste toner is even. If as follows, repeat step 8):
 - The surface of the magnet roller is coated in distinct lines.
 - The surface has dents in some areas.
 - The surface has lumps of toner.

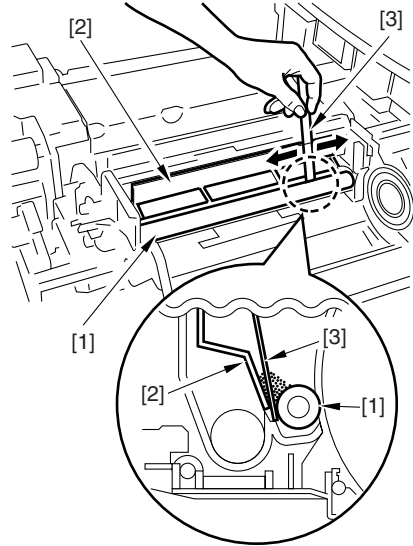

F05-402-07

- 10) Remove the cleaning blade from the cleaning blade assembly. (See 5.8.2.b in Chapter 2.)
- 11) Butt the edge of the cleaning blade [7] that has been turned over or newly mounted against the rear of the blade cleaning plate [8].



When butting the blade, be sure to force it so that there is no gap.

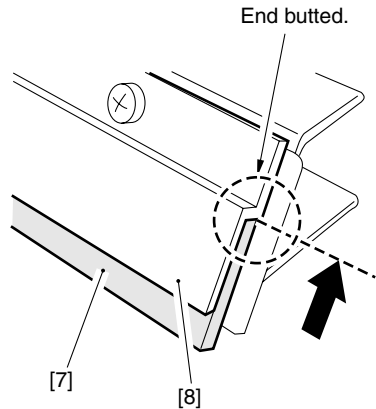

F05-402-08

- 12) Secure the blade retaining plate with screws as indicated.
- For now, temporarily tighten screws 1 through 5.



With the blade pressed down by the plate, temporarily tighten the screws.

- Fully tighten screws 6 through 10.

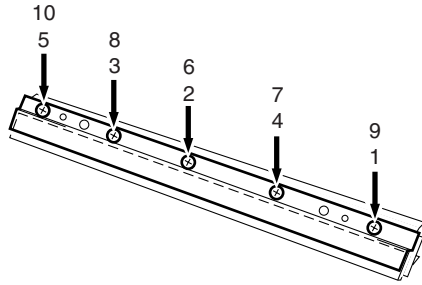

F05-402-09

- 13) Apply toner to the area of the cleaning blade coming into contact with the photosensitive drum, and mount the cleaning blade.



When mounting the cleaning blade, be sure to put the blade sub plate between the blade support plate and the blade back plate.



After mounting the cleaning blade, rotate the drum; if the toner is not collected by the cleaning blade, repeat the foregoing steps. If it is not corrected after tightening the screws once again, replace the cleaning blade.

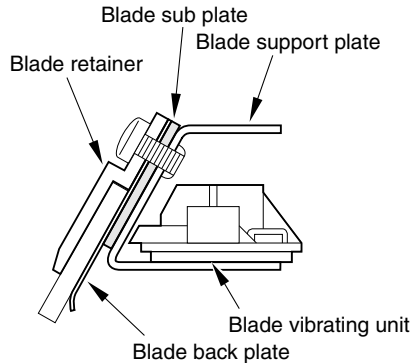

F05-402-10

CHAPTER 6

TROUBLESHOOTING

1 Guide to the Troubleshooting Tables

The troubleshooting tables used in this chapter are based on commonly found troubleshooting flow charts; study the following for an idea of how to use the tables:

EX: The AC power is absent.

Power plug	1) Is the power plug connected? NO: Connect the plug.
Covers	2) Is the front cover closed properly? NO: Close the cover.
Main power supply	3) Is the rated voltage present at the outlet? NO: The problem is not of the copier. Advise the user.
-----	4) Is the rated voltage present between J1-1 and J1-2? (J1 is found near the power cord base.) YES: Go to step 6).

Rest omitted.

- To find out the possible cause (faulty part) of a specific problem, see the “Cause” column of the table. In the case of the above, i.e., “absence of AC power,” suspect that the power plug may be disconnected, the front cover may not be closed properly, or the main power supply is absent.
- To find out checks to make and actions to take for a specific problem, make the check indicated under “Checks” and answer the question in terms of “YES” or “NO”; if yes, take the action indicated, otherwise, go to the next step.

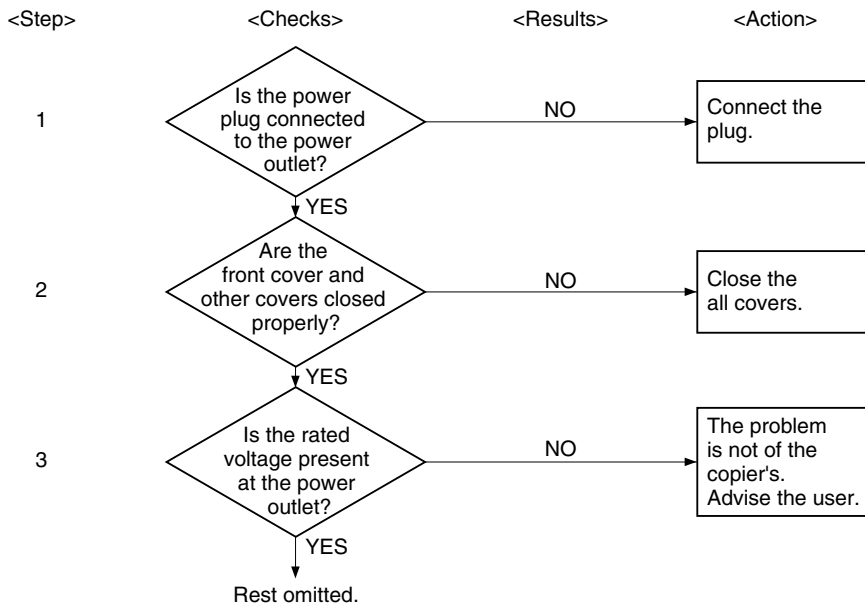

F06-100-01

- When checking the voltage using a meter, you may encounter an expression like the following: “Measure the voltage between J109-1 (+) and -2 (-) on the DC controller PCB,” the symbol (+) indicating the positive probe of the meter, while the symbol (-) indicating the negative probe of the meter. In the case of the example, you are expected to connect the positive probe to J109-1 and the negative probe to J109-2.

1.1 Image Adjustment Basic Procedure

1.1.1 Making Pre-Checks

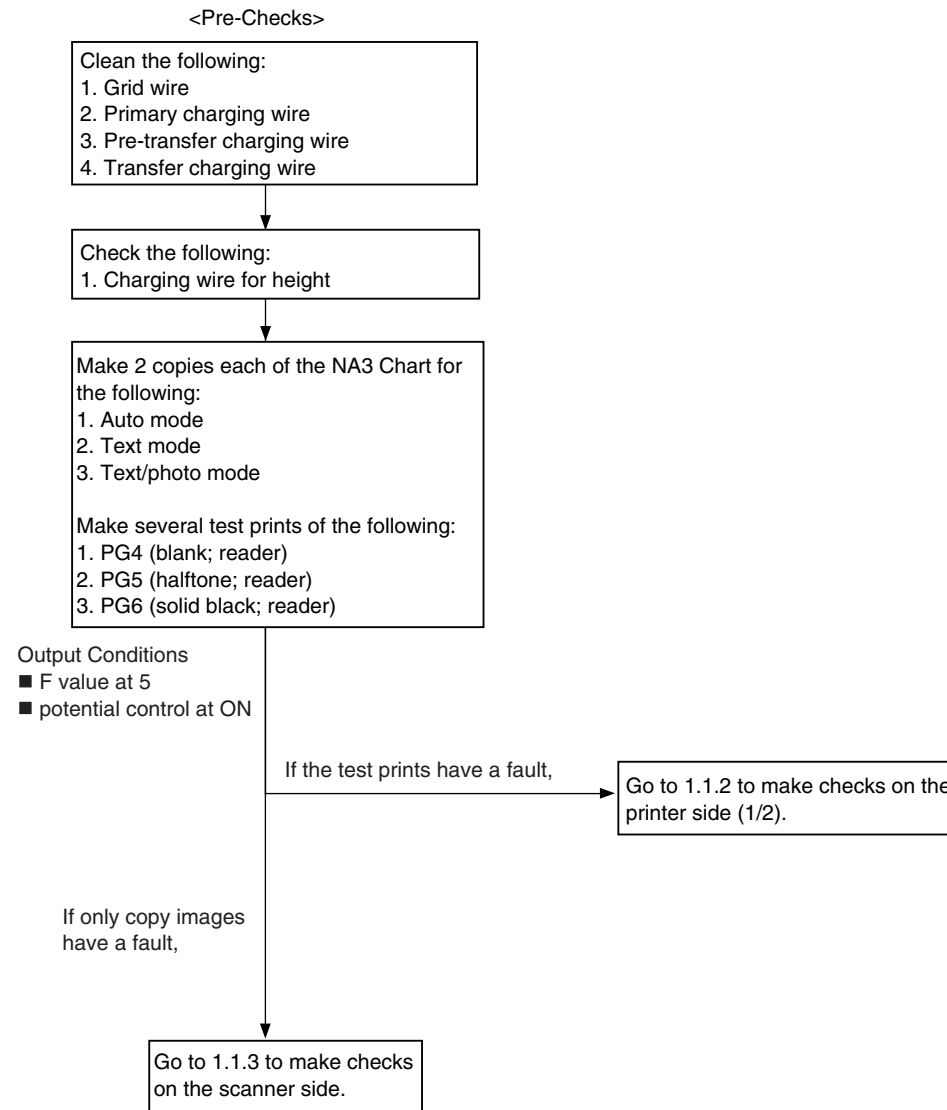

F06-101-01

1.1.2 Making Checks on the Printer Side (1/2)

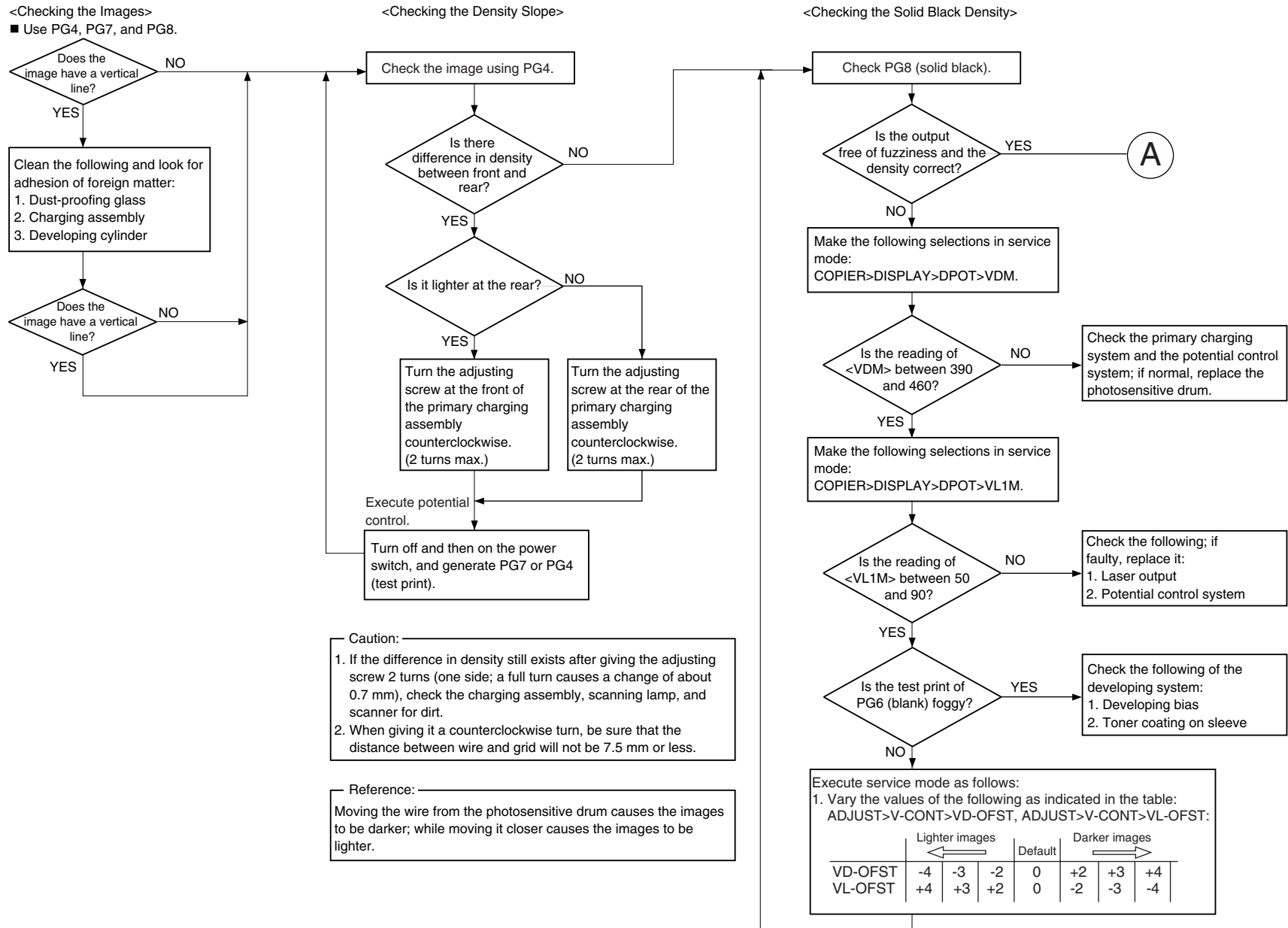

1.1.3 Making Checks on the Printer Side (2/2)

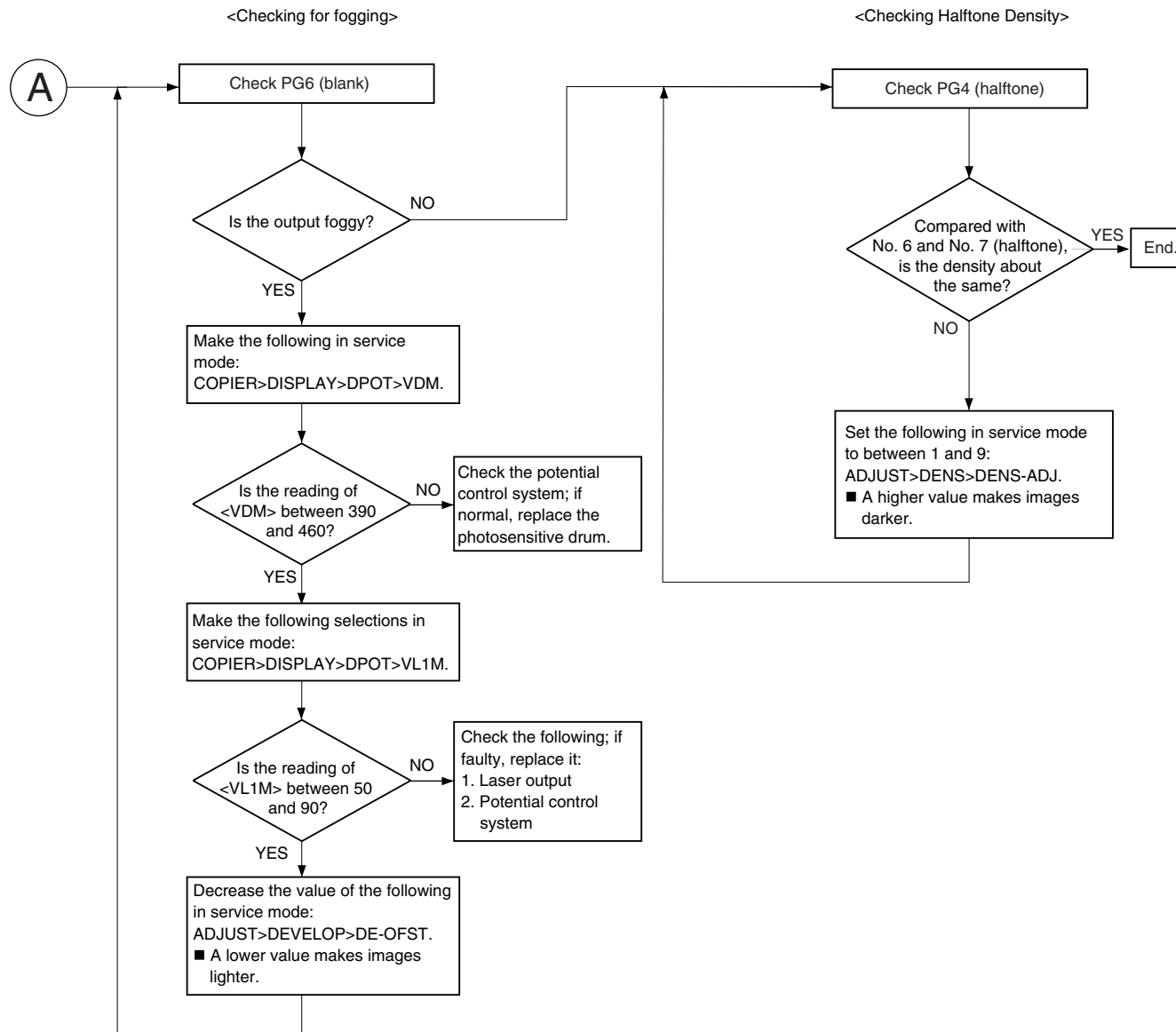

F06-101-03

1.1.4 Making Checks on the Scanner Side

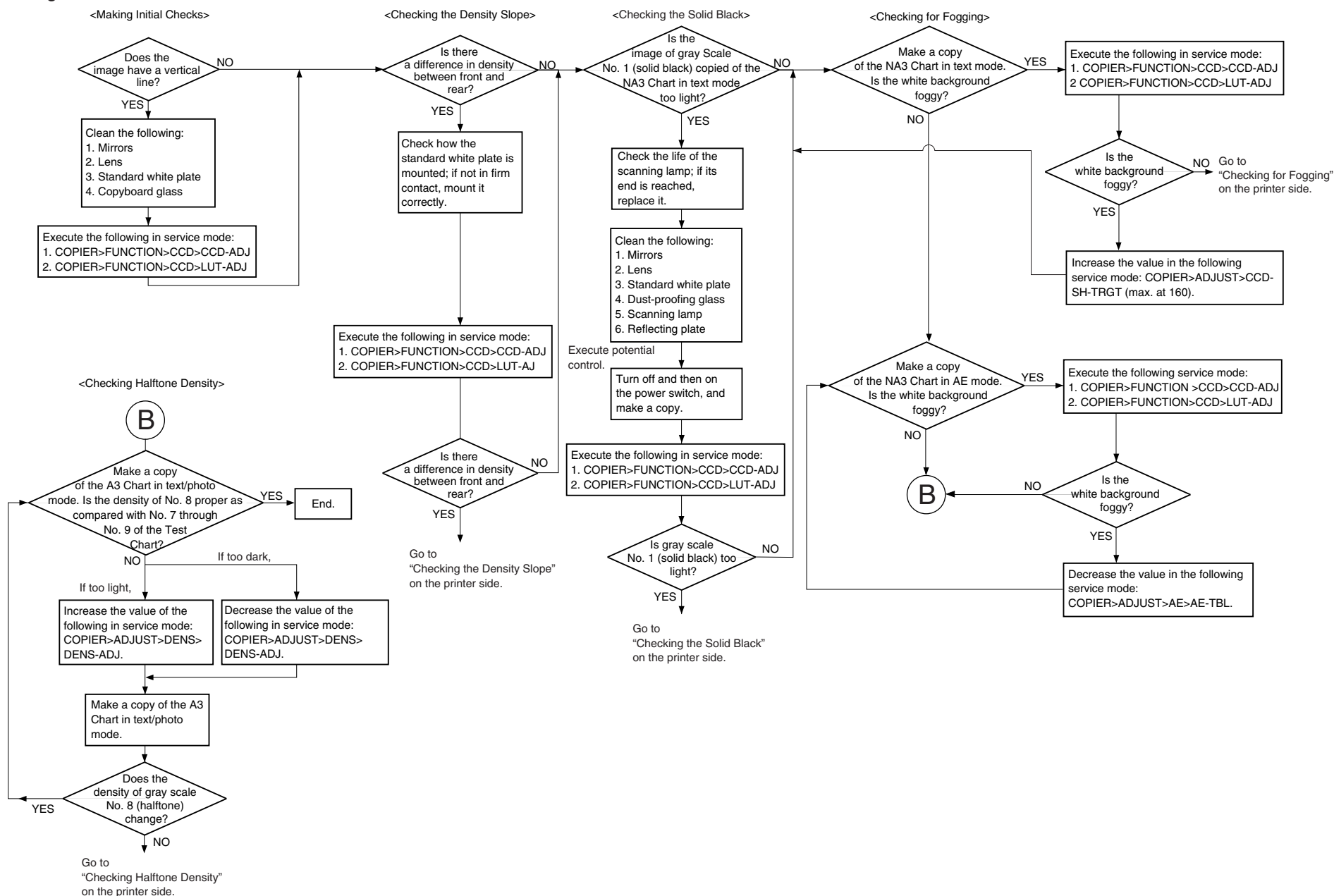

Caution:

- Be sure to check the block (front, rear) for melting, thermal deformation, cracking, or discoloration caused by leakage. If found, be sure to replace it with a new one without delay.
- Be sure to check and clean the block (front, rear) thoroughly (all the way to its inside).
- Never use a cloth carrying any metal powder.
- Unless specifically indicated, do not use a moist cloth. Use lint-free paper to dry wipe, and use alcohol thereafter. Be sure that the alcohol has completely evaporated before fitting the part back into the machine.
- Be sure to provide scheduled servicing and replace periodically replaced parts at specific intervals.

Part	Tool/agent	Work/remarks
Pre-exposure map	Alcohol	Cleaning
Copyboard glass	Alcohol	Cleaning
Scanning lamp	Lint-free paper	Dry wiping
Standard white plate	Lint-free paper	Dry wiping
Reflecting plate	Blower brush	Cleaning
No. 1 through No. 3 mirrors	Blower brush or lint-free paper	Cleaning or using blower brush; if dirt is excessive, dry wiping with lint-free paper

Part	Tool/agent	Work/remarks
Separation claw	Solvent and lint-free paper	Cleaning
Upper roller, Lower roller	Cleaning oil, lint-free paper	Cleaning
Paper guide	Solvent and lint-free paper	Cleaning
Feeding assembly	Moist cloth (Note 1)	Cleaning
Feeding assembly		Cleaning
Re-pickup assembly, Reversing roller	Alcohol and lint-free paper	Cleaning
Re-pickup assembly, Pickup roller, Registration roller	Alcohol and lint-free paper	Cleaning

Note 1: Be sure not to leave any droplets of water.

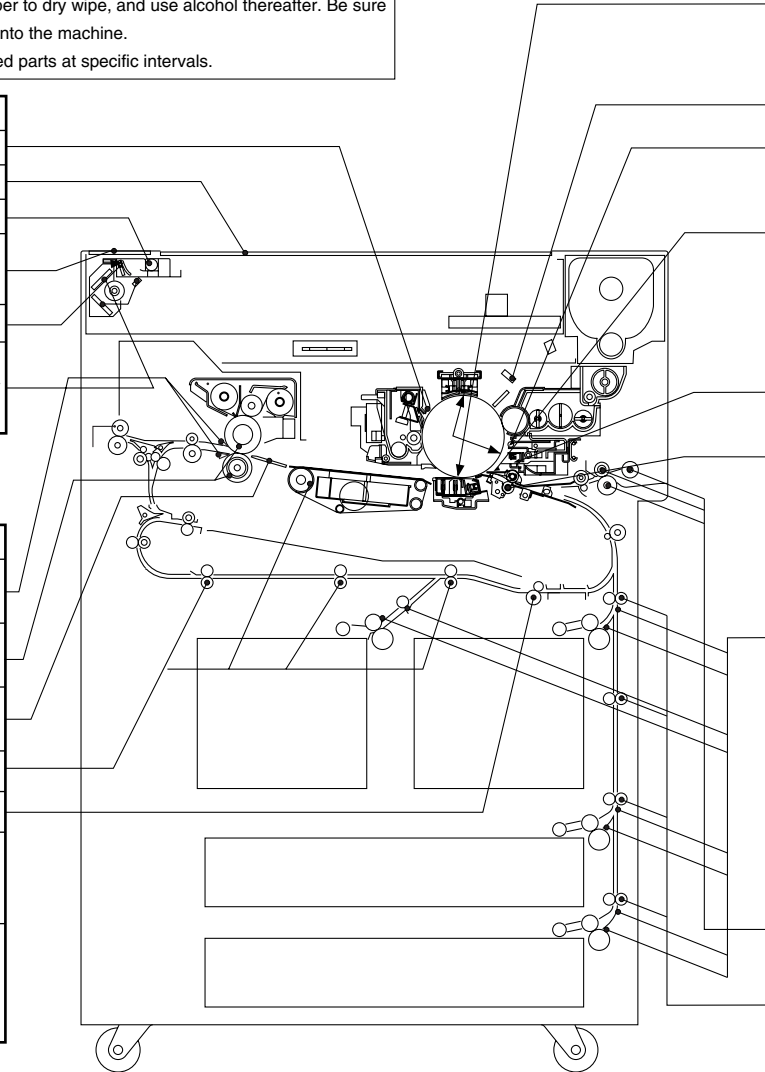

Part	Tool/agent	Work/remarks
Primary charging assembly, Transfer/separation charging assembly, Pre-transfer charging assembly	Alcohol and lint-free paper	Dry wiping; then, cleaning with lint-free paper moistened with alcohol
Dust-proofing glass	Lint-free paper	Cleaning
Dust-collecting roller		Disposing of toner trapped dust-collecting roller
Transfer guide (upper, lower)	Alcohol and lint-free paper	Dry wiping; then, cleaning with lint-free paper moistened with alcohol
Pre-transfer exposure lamp	Alcohol and lint-free paper	Dry wiping; then, cleaning with lint-free paper moistened with alcohol
Developing assembly base	Moist cloth (Note 1)	Cleaning
Registration roller	Alcohol and lint-free paper	Cleaning

Note 1: Be sure not to leave droplets of water.

Part	Tool/agent	Work/remarks
Prism (pickup sensor) (feeding sensor) (vertical path sensor)	Blower brush or lint-free paper	<ul style="list-style-type: none"> • Cleaning with lower brush • If dirt is excessive, dry wiping with lint-free paper (Do not use solvents other than the one indicated.)

Part	Tool/agent	Work/remarks
Manual feed tray, Pickup roller, Feed roller	Alcohol and lint-free paper	Cleaning
Vertical path roller	Alcohol and lint-free paper	Cleaning

F06-101-05

2 Standards and Adjustments

2.1 Image Adjustment-Related Items

Adjusting the Image Position

Be sure to adjust the image position in the following sequence:

1. image position adjustment of printer output
2. image position adjustment for copier output (book mode)
3. image position adjustment for copier output (ADF mode)

2.1.1 Adjusting the Image Position for Printer Output

Image Position Standards

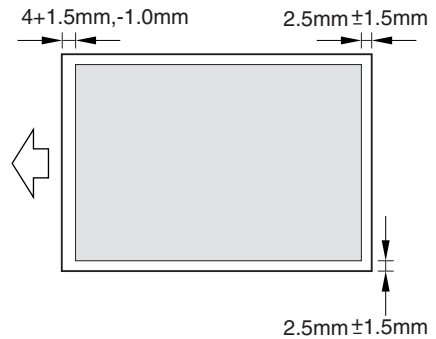

F06-201-01

1) Adjusting the Image Position in Main Scanning Direction

Check to make sure that the value for the following matches that indicated on the service label: COPIER>ADJUST>LASER>PVE-OFST. If different, enter the value indicated on the service label.



The value is used to center the image position on the photosensitive drum. Changing the value can cause deformation at the edge of an image.

- 2) Check to make sure that the value of the following is '106':
COPIER>ADJUST>BLANK>BLANK-T. If not, enter '106'.
- 3) Adjusting the Image Leading Edge Margin
Generate output using the following to check the image leading edge margin:
COPIER>TEST>PG5>
Standard: 4 +1.5 mm, -1.0 mm
Adjustment: COPIER>ADJUST>FEED-ADJ>REGIST
 - A higher value increases the margin.
 - A lower value decreases the margin.

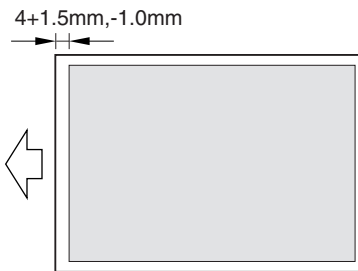

F06-201-02

- 4) Adjusting the Image Trailing Edge Margin
Generate output of the following to check the image trailing edge margin:
COPIER>TEST>PG5.
Standard: 2.5 ±1.5 mm
Adjustment: COPIER>ADJUST>BLANK>BLANK-B
 - A higher value increases the margin.
 - A lower value decreases the margin.

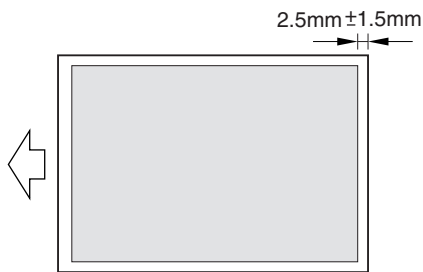

F06-201-03

5) Adjusting the Image Front Margin for Each Source of Paper

Make the following selections to select '1' (right deck): COPIER>TEST>PG-PICK.

Then, generate the following to check the image front margin: COPIER>TEST>PG56.

Likewise, make the following selections to select '2', '3', '4', and '8':

COPIER>TEST>PG5. Then, generate COPIER>TEST>PG5 to check the image front margin.

Standard: 2.5 ± 1.5 mm

PG-PICK 1: right deck

PG-PICK 2: left deck

PG-PICK 3: cassette 3

PG-PICK 4: cassette 4

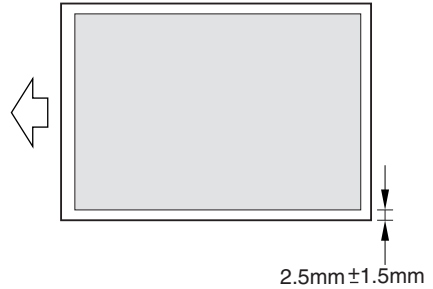

F06-201-04

Adjustment: Adjusting the Fixing Position of Each Source of Paper

■ Front Deck (left, right)

- 1) Slide out the deck, and loosen the 4 screws [2] and the 2 fixing screws [3] of the cassette front cover [1].

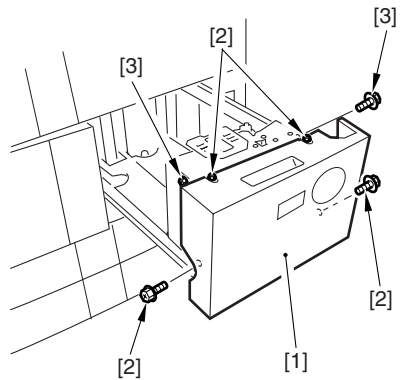

F06-201-05

- 2) Move the cassette guide assembly (front) [4] to the front or the rear to make adjustments.

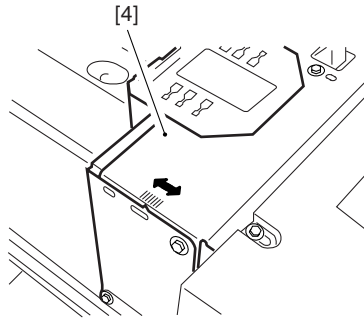

F06-201-06

■ Cassette (3/4)

- 1) Slide out the cassette, and remove the 2 screws [2] for the cassette front cover [1].

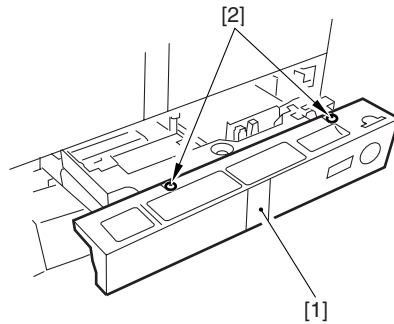

F06-201-07

- 2) Loosen the 2 fixing screws [3] found on the left/right of the cassette, and adjust the position using the fixing screw [4].

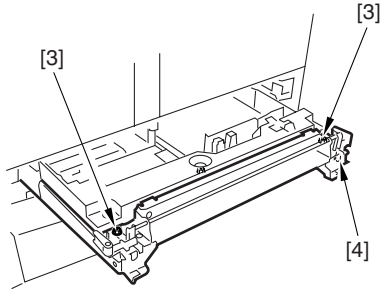

F06-201-08



If you have adjusted the cassette 3 or cassette 4, be sure to execute the following:

- If you have replaced the cassette 3,
COPIER>ADJUST>CST-ADJ>C3-STMTR
COPIER>ADJUST>CST-ADJ>C3-A4R

- If you have replaced the cassette 4,
COPIER>ADJUST>CST-ADJ>C4-STMTR
COPIER>ADJUST>CST-ADJ>C4-A4R

2.1.2 Adjusting the Image Position of Copier Output (book mode)



Make these adjustments only after you have adjusted the image position of printer output.

1) Adjusting the Image Leading Edge Non-Image Width

Place the NA3 Test Chart on the copyboard glass, and make a copy to check the image leading edge non-image width:

Standard: $4 +1.5 \text{ mm}, -1.0 \text{ mm}$

Adjustment: COPIER>ADJUST>ADJ-XY>ADJ-X

- A higher value increases the margin.
- A lower value decreases the margin.

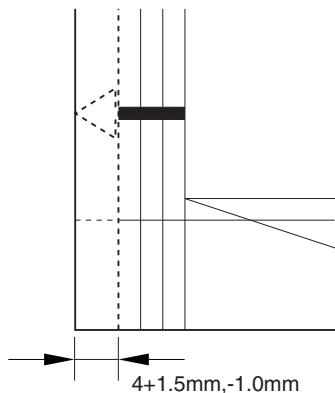

F06-201-09

2) Adjusting the Image Front Non-Image Width

Place the NA3 Test Chart on the copyboard glass, and make a copy to check the image front non-image width.

Standard: $2.5 \pm 1.5 \text{ mm}$

Adjustment: COPIER>ADJUST>ADJ-XY>ADJ-Y

- A higher value increases the margin.
- A lower value decreases the margin.

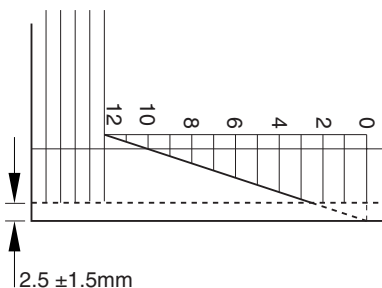

F06-201-10

- 3) Adjusting the Image Front Non-Image Width of Double-Sided Copy Images
 Place the NA3 Test Chart on the copyboard glass, and make a double-sided copy to check the front non-image width of the 2nd side.

Standard: 2.5 ± 2.0 mm

Adjustment: COPIER>ADJUST>FEED-ADJ>ADJ-REFER

- A higher value increases the margin.
- A lower value decreases the margin.

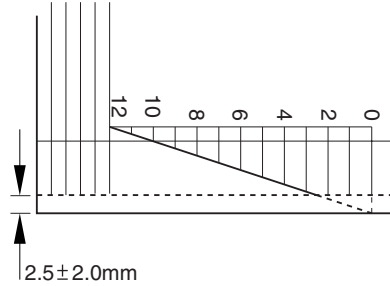

F06-201-11

- 4) Adjusting the Image Front Margin for the Manual Feed Tray and the Side Paper Deck (accessory)

Place the NA3 Test Chart on the copyboard glass, and make a double-sided copy to check the front non-image width of the 2nd side image.

Standard: 2.5 ± 1.5 mm

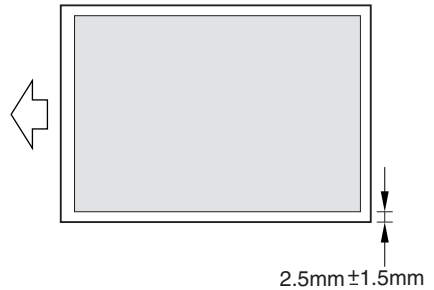

F06-201-12

Adjustment: Adjusting the Fixing Plate of Each Source of Paper

■ Manual Feed Tray

- 1) Loosen the 2 mounting screws [1] of the manual feed tray to adjust the manual feed tray position.

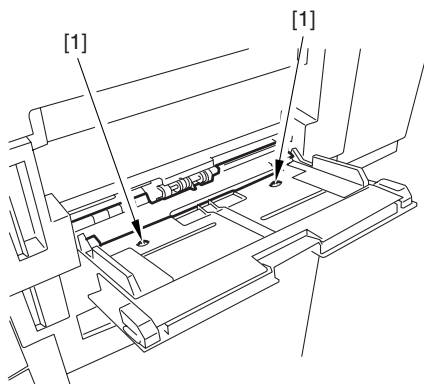

F06-201-13

■ Side Paper Deck (accessory)

- 1) Slide out the compartment, and adjust the position of the latch plate [1] of the deck open solenoid using the 2 screws [2]. (At this time, use the index [3] on the latch plate as a reference.)

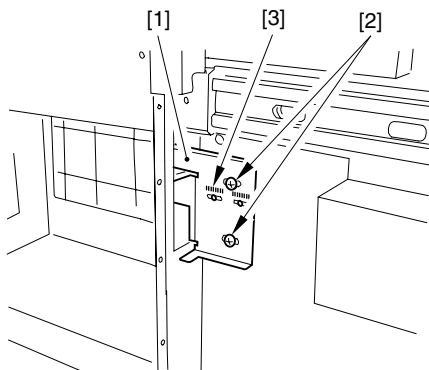

F06-201-14

2.1.3 Adjusting the Image Position of Copier Output (ADF mode)



Make these adjustments after you have adjusted the “image position of printer output” and the “image position of copier output (book mode).”

1) Adjusting the Image Leading Edge Non-Image Width

Place an A3 test chart and an A4 test chart in the ADF original tray, and make a copy to check the image leading edge non-image width.

Standard: 4 ± 1.5 mm, -1.0 mm

Adjustment: FEEDER>ADJUST>STRD-S (A4 original)

FEEDER>ADJUST>STRD-L (A3 original)

- A higher value increases the margin.
- A lower value decreases the margin.

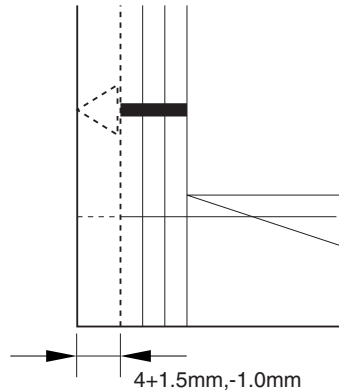

F06-201-15

2) Adjusting the Image Front Non-Image Width

Place an A3 size test chart in the ADF original tray, and make a copy to check the image front non-image width.

Standard: 2.5 ± 1.5 mm

Adjustment: Adjust the ADF original tray fixing position.

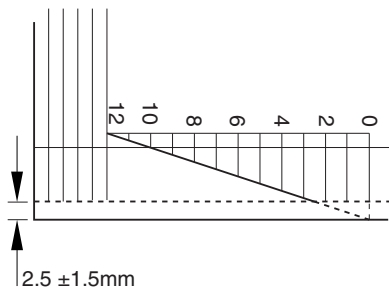

F06-201-16

2.2 Scanning System

2.2.1 Replacing the Scanner Drive Cable

See 2.9.2.b. “Scanner Drive Cable” in Chapter 2.

2.2.2 Adjusting the Scanner Mirror Base

See 2.9.2.b. “Scanner Drive Cable” in Chapter 2.

2.2.3 When Replacing the Standard White Plate

See 2.9.4.g. “When Replacing the Standard White Plate” in Chapter 2.

2.2.4 When Replacing the Scanning Lamp

See 2.9.1.c. “When Replacing the Scanning Lamp” in Chapter 2.

2.3 Image Formation System

2.3.1 Stringing the Grid Wire of the Primary Charging Assembly

See 5.8.3.d “Stringing the Grid Wire of the Primary Charging Assembly” in Chapter 2.

2.3.2 Stringing the Charging Wire of the Charging Assemblies

See 5.8.3.c “Stringing the Charging Wire” in Chapter 2.

2.3.3 Mounting the Drum Cleaning Blade

See 4.2.2 “Work 2” in Chapter 5.

2.4 Pickup/Feeding System

2.4.1 Orientation of the Deck/Cassette Pickup Roller

The deck/cassette pickup roller may be mounted by reversing the steps used to remove it; however, keep the following in mind:

- The pickup rollers used at the front and the rear of the machine are not interchangeable.
- The collar of the pickup roller used at the front of the machine is gold-colored.

When mounting the pickup roller [1] to the pickup assembly, be sure that the round marking [2] found on the side of the roller and the round marking [3] on the collar (gold-colored) are toward the front of the machine.

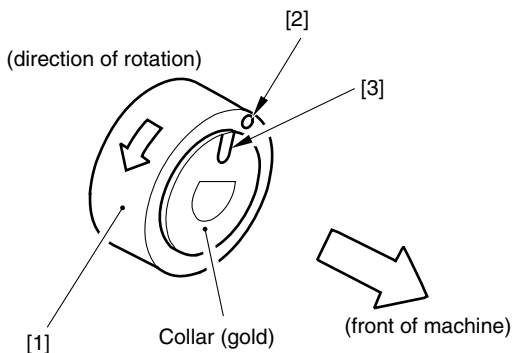

F06-204-01

- The collar of the pickup roller used at the rear is silver-colored. When mounting the pickup roller [4] to the pickup assembly, be sure that the round marking [5] on the side of the roller and the round marking [6] on the collar (silver-colored) are toward the rear of the machine.

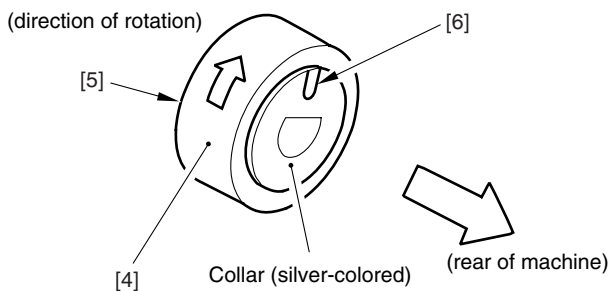

F06-204-02

2.4.2 Orientation of the Deck/Cassette Separation Roller

When replacing the separation roller, be sure that it is oriented as shown

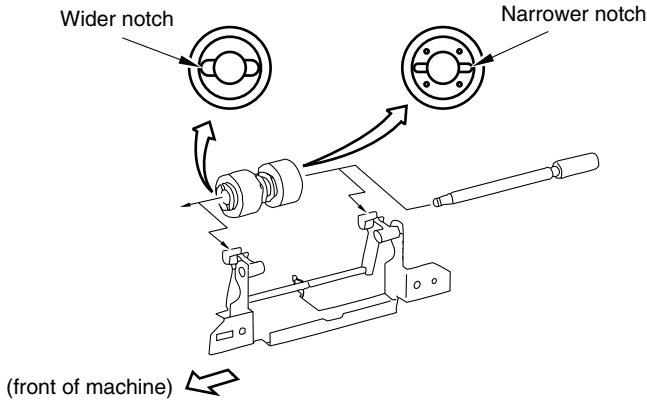

F06-204-03

2.4.3 Orientation of the Feeding Roller of the Deck/Cassette Pickup Assembly

When mounting the feeding roller assembly to the deck/cassette pickup assembly, be sure that the belt pulley [2] is to the front of the machine. When mounting the feeding roller [3] to the feeding roller shaft [4], be sure that the round marking [5] is toward the front of the machine.

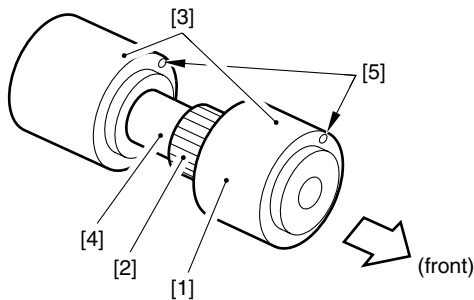

F06-204-04

2.4.4 Orientation of the Pickup Roller of the Manual Feed Tray/Side Paper Deck

The pickup roller may be mounted by reversing the steps used to remove it; however, keep the following in mind:

- The pickup rollers used at the front and the rear of the machine are not interchangeable.
- The collar of the pickup roller used at the front of the machine is silver-colored.

When mounting the pickup roller [1] to the pickup assembly, be sure that the round marking [2] of the color (silver-colored) is toward the front of the machine.

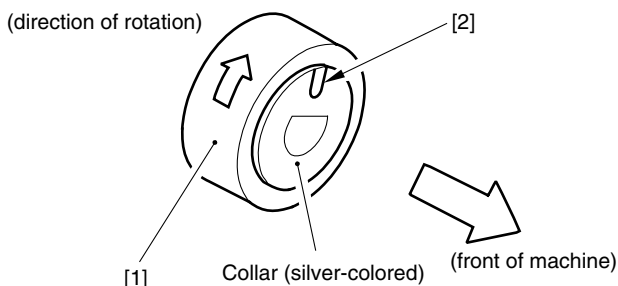

- [1] Pickup roller
- [2] Marking (collar)

F06-204-05

- The collar of the pickup roller used at the rear of the machine is gold-colored.

When mounting the pickup roller [4] to the pickup assembly, be sure that the round marking [5] on the side of the roller and the round marking [6] on the collar (gold-colored) are toward the rear of the machine.

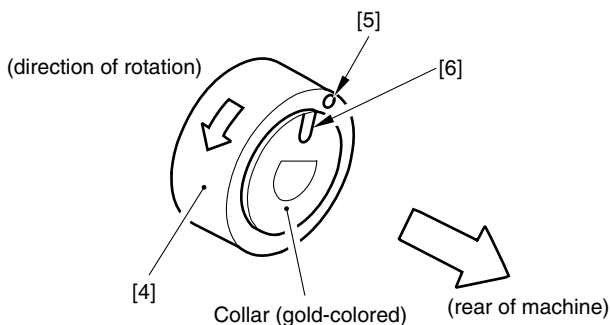

- [4] Pickup roller
- [5] Marking (roller)
- [6] Marking (collar)

F06-204-06

2.4.5 Orientation of the Feeding Roller of the Manual Feed Tray

When mounting the feeding roller assembly [1] to the manual feed tray pickup assembly, be sure that the belt pulley [2] is toward the front of the machine. When mounting the feeding roller [3] to the feeding roller shaft [4], be sure that the round marking [5] is toward the front of the machine.

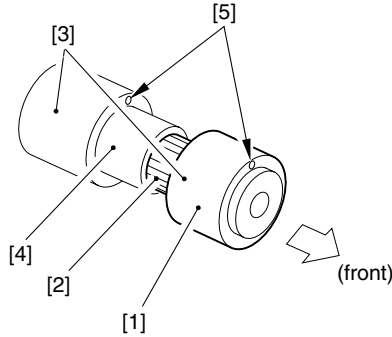

F06-204-07

2.4.6 Orientation of the Feeding Roller of the Side Paper Deck

When mounting the feeding roller assembly [1] to the side paper deck pickup assembly, be sure that the belt pulley [2] is toward the front of the machine. When mounting the feeding roller [3] to the feeding roller shaft [4], be sure that the round marking [5] is toward the rear of the machine.

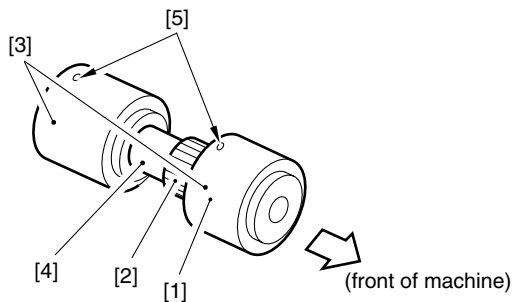

F06-204-08

2.4.7 Adjusting the Pressure of the Deck/Cassette Separation Roller

If double feeding or pickup failure occurs during pickup, adjust the position of the pressure spring of the separation roller.

- If double feeding occurs, move the hook of the spring in the direction of arrow B.
- If pickup failure occurs, move the hook of the spring in the direction of arrow A.

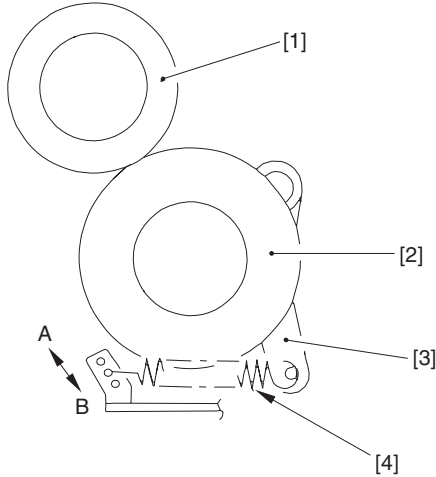

- | | |
|--------------------|-----------------------|
| [1] Feeding roller | [2] Separation roller |
| [3] Locking lever | [4] Pressure spring |

F06-204-09

2.4.8 Adjusting the Pressure of the Pickup/Feeding Roller of the Manual Feed Tray

If double feeding or pickup failure occurs during pickup, adjust the position of the pressure spring of the separation roller.

- If double feeding occurs, move the hook of the spring in the direction of arrow A.
- If pickup failure occurs, move the hook of the spring in the direction of B.

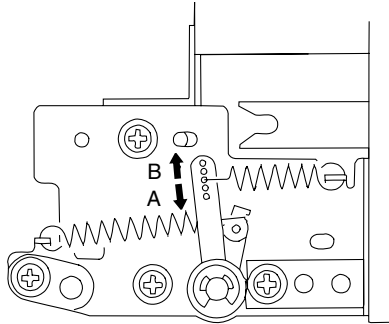

F06-204-10

2.4.9 Locations of the Solenoid

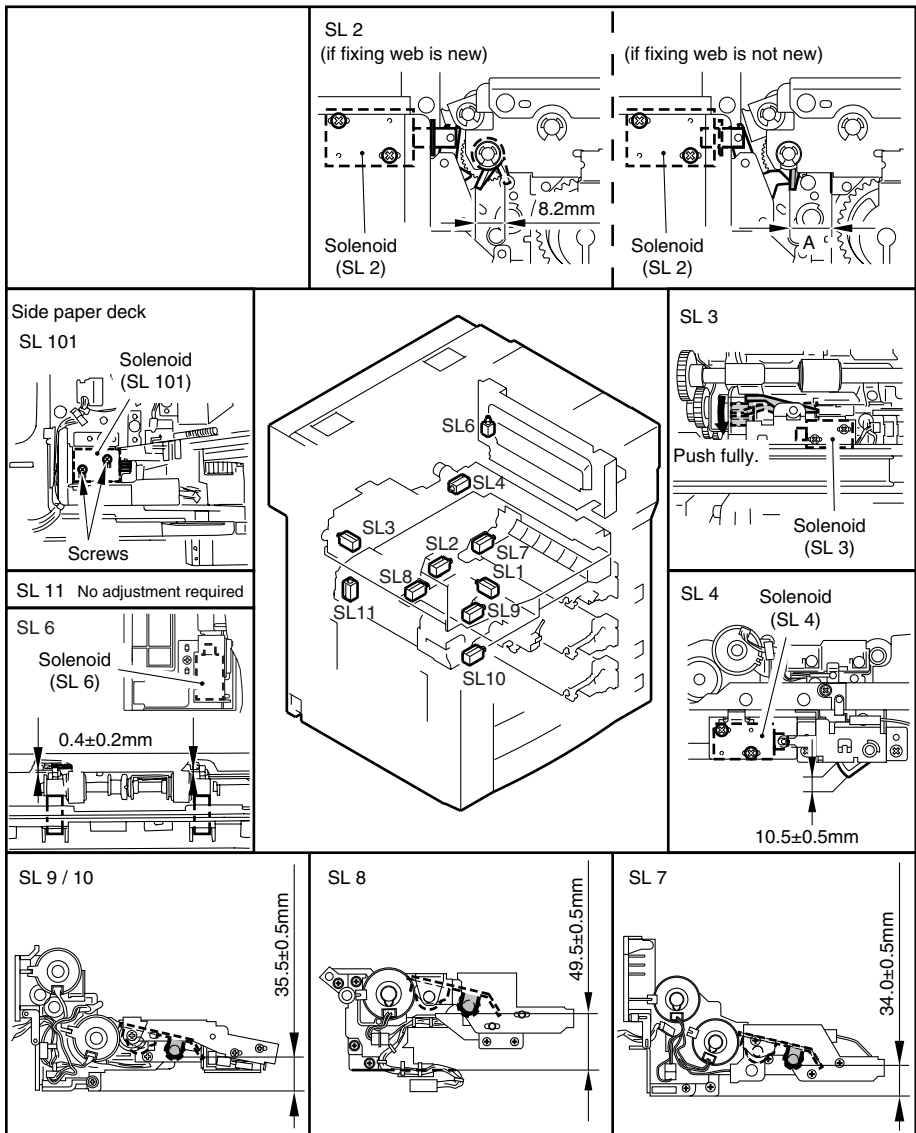

F06-204-11

2.4.10 Location of the Fixing Web Solenoid (SL2)

a. If the Fixing Web Is New

Use the position of the solenoid [1] using the screw [2] so that the travel of the drive lever is 8.2 mm.

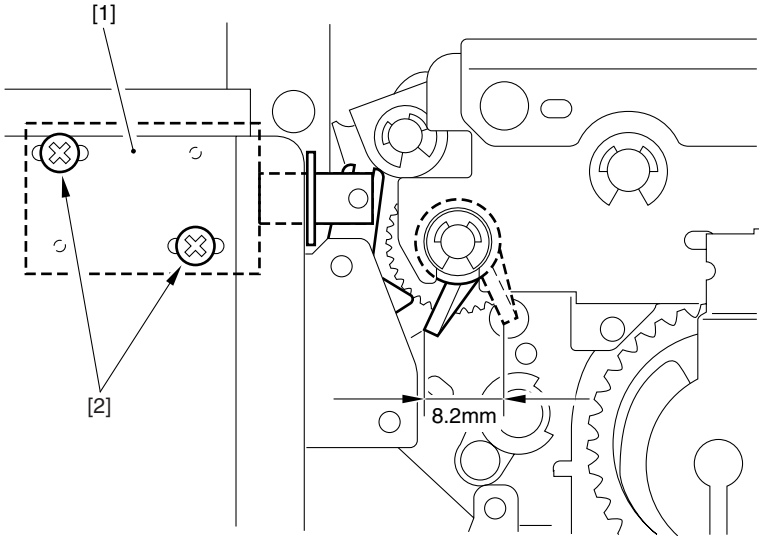

F06-204-12

b. If the Fixing Web Is Not New

Before removing the solenoid, check the position [A] of the drive lever when the solenoid [1] is ON. After replacing the solenoid, make adjustments using the screw [2] so that the position of the drive lever is the same (when the solenoid is ON).

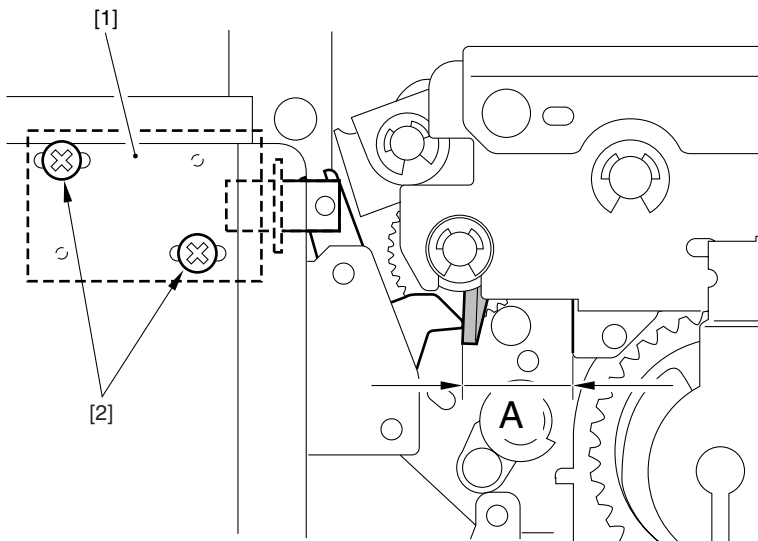

F06-204-13

2.4.11 Position of the Delivery Flapper Solenoid (SL3)

Use the screw [2] to adjust the position of the solenoid [1] so that the drive lever is fully pushed when the solenoid is ON (i.e., when the steel core is drawn).

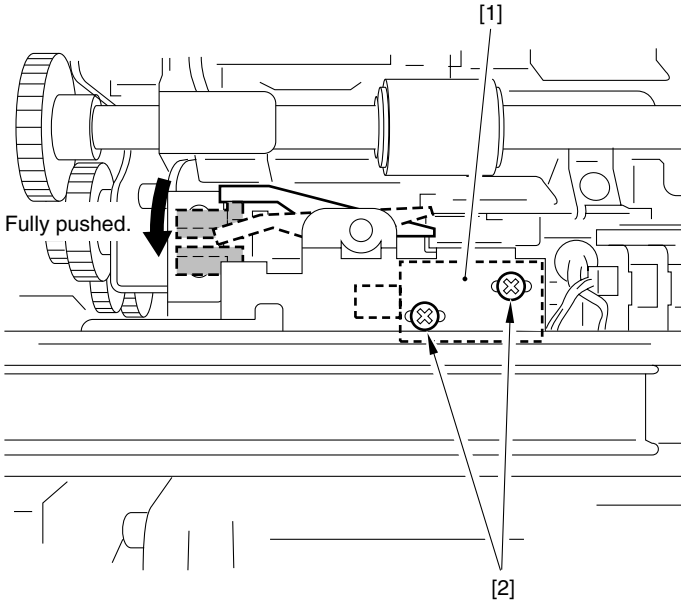

F06-204-14

2.4.12 Position the Fixing/Feeder Unit Locking Solenoid (SL4)

Use the screw [3] to adjust the position of the solenoid [1] so that the locking lever [2] is 10.5 ± 0.5 mm away from the frame when the solenoid is ON (i.e., when the steel core is drawn).

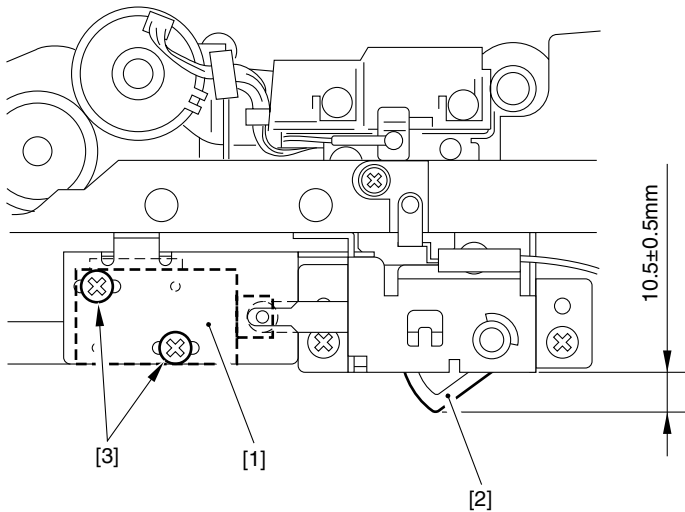

F06-204-15

2.4.13 Position of the Multifeeder Latch Solenoid (SL6)

Slide the solenoid in the direction of A so that the gap between the shutter [1] and the shutter plate [2] is 0.4 ± 0.2 mm when the solenoid is drawn.

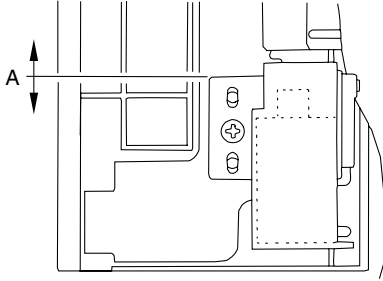

F06-204-16

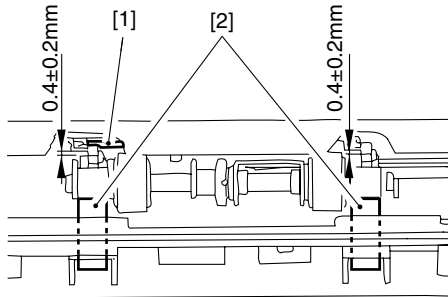

F06-204-17

2.4.14 Position of the Deck (right) Pickup Solenoid (SL7)

Use the screw [3] so that the distance from the pickup unit bottom of each cassette holder and the bushing bottom edge of the A roller support plate is 34.0 ± 0.5 mm when the plunger of the pickup roller releasing solenoid is drawn (as occurring when [1] and [2] are operated as shown). (After adjustment, make sure that the distance between the paper face and the A roller is 2.5 ± 0.5 mm when the A roller is in UP position.)

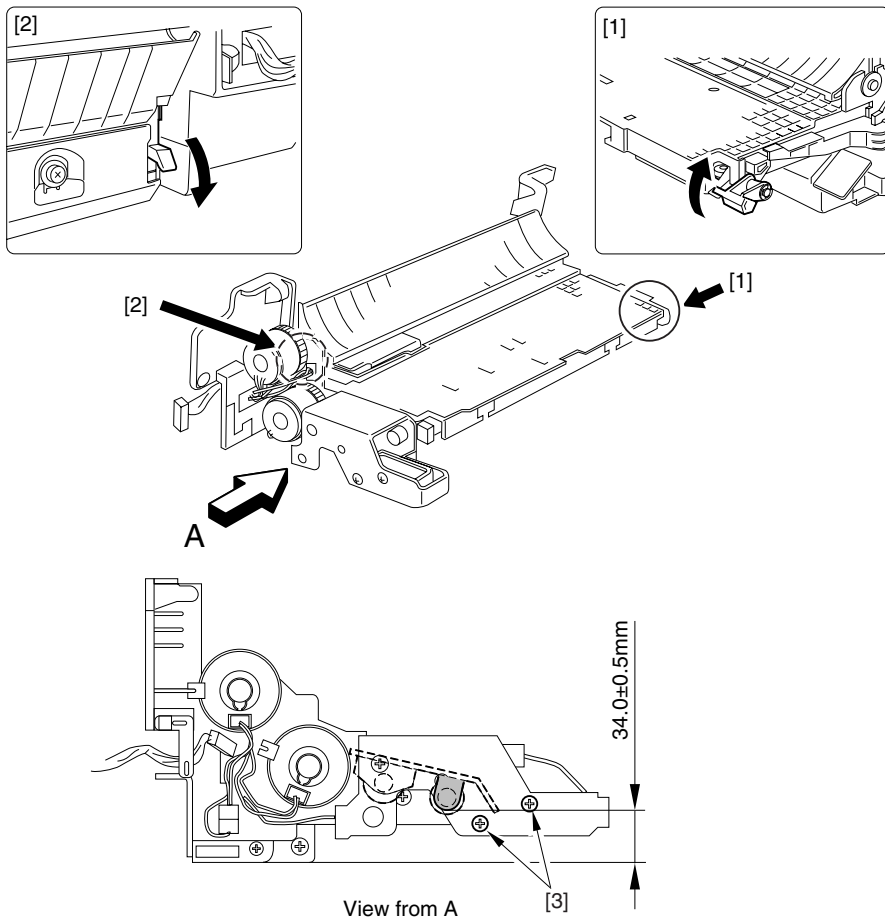

F06-204-18

2.4.15 Position of the Deck (Left) Pickup Solenoid (SL8)

Use the screw [3] so that the distance from the pickup unit bottom face to the bushing bottom edge of the A roller support plate is 49.5 ± 0.5 mm when the plunger of the pickup releasing solenoid is drawn (as occurring when [1] and [2] are operated as shown). (After adjustment, make sure that the distance between the paper face and the A roller is 2.5 ± 0.5 mm when the A roller is in UP position.)

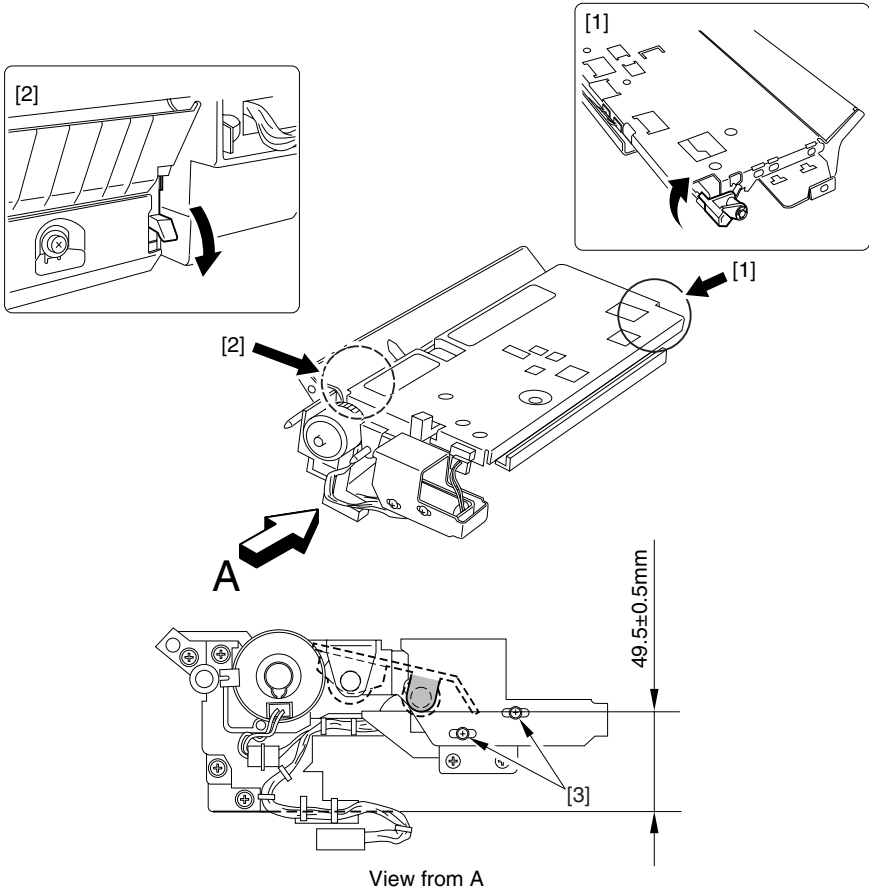

View from A

F06-204-19

2.4.16 Position of the Cassette 3/4 Pickup Solenoid (SL9/10)

Use the screw [3] so that the distance from the pickup unit bottom face of each cassette holder and the bushing bottom edge of the A roller support plate is 35.5 ± 0.5 mm when the plunger of the pickup roller releasing solenoid is drawn (as occurring when [1] and [2] are operated as shown). (After adjustment, make sure that the distance between the paper face and the A roller is 2.5 ± 0.5 mm when the A roller is in UP position.)

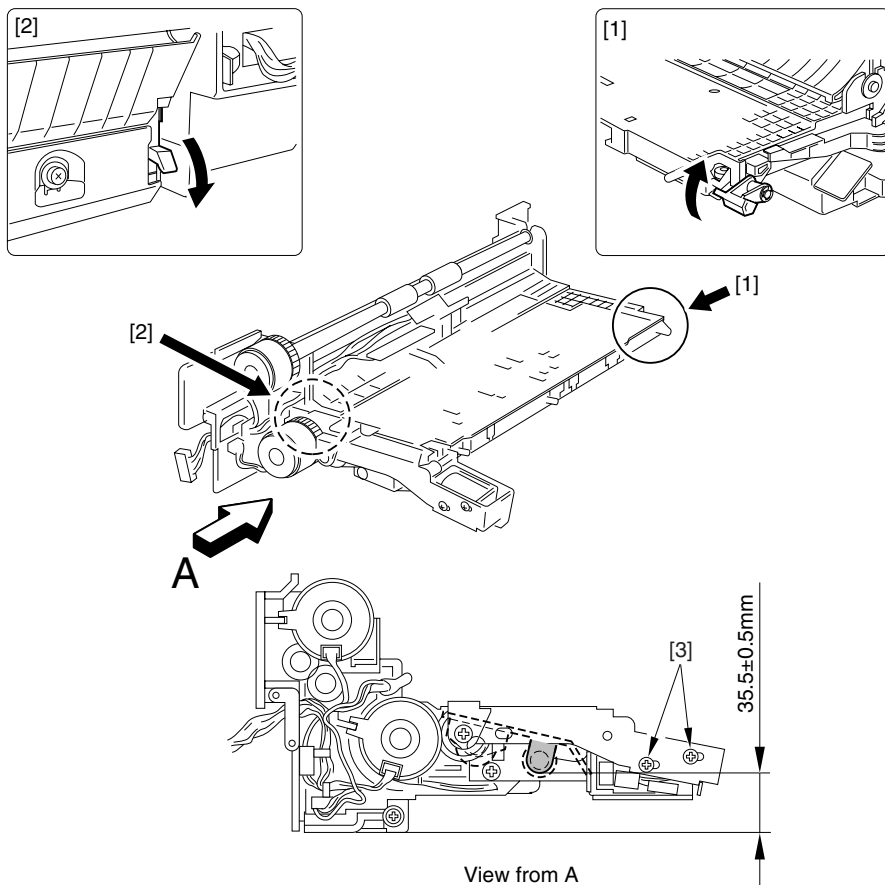

F06-204-20

2.4.17 Position of the Side Paper Deck Pickup Roller Releasing Solenoid

Before removing the deck pickup roller releasing solenoid [1] from the support plate, make mental notes of the positions of the 2 fixing screws [2] of the solenoid with reference to the index on the support plate. (Or, mark the position of the solenoid on the support plate with a scribe.)

If you are replacing the solenoid on its own, you must secure it in its initial position.

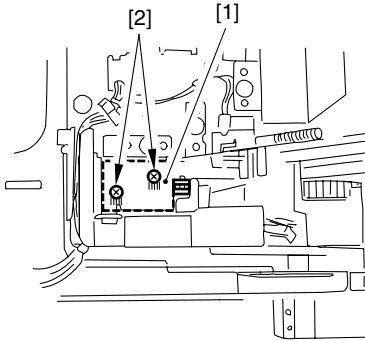

F06-204-21

2.4.18 Fitting the Side Guide Timing Belt of the Manual Feed Tray Assembly

Butt the rack plate [1] of the manual feed tray against section A (open state).

Move the slide volume [2] in the direction of B, and fit the timing belt [3] to the pulley [4].

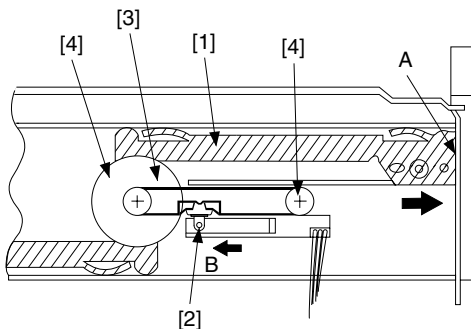

F06-204-22

2.4.19 Fitting the Drive Belt

Fit the drive belt to the pulleys and rollers as follows:

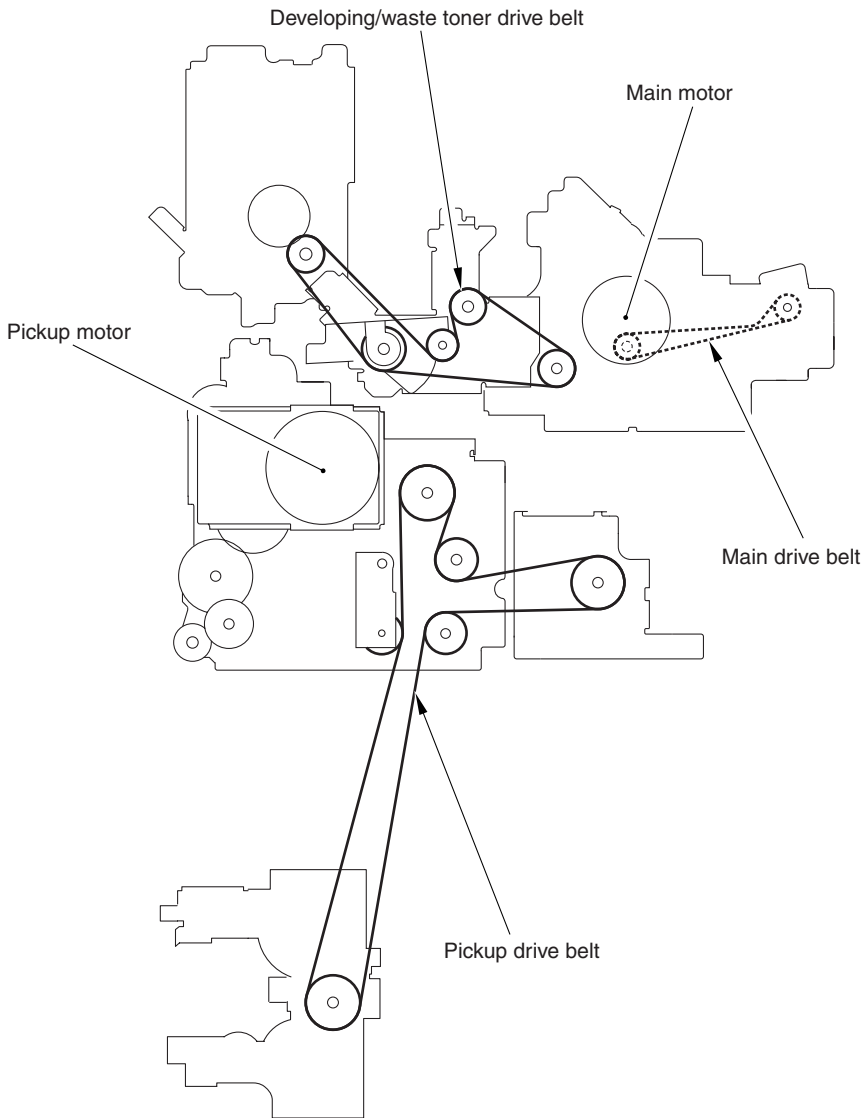

F06-204-23

2.5 Fixing System

2.5.1 Points to Note When Mounting the Fixing Heater

1. Do not touch the heater surface.
2. For both heaters, mount so that the side with the longer heater harness is toward the front.
3. Viewing from the front of the fixing assembly, mount the main heater on the right (for 200V model, 1150 W; for 208V model, 1220 W; for 230V model, 1185 W) and the sub heater on the left (for 200V model, 565 W; for 208V model, 600 W; for 230V model, 645 W).
4. Viewing from the rear, connect the right side of the faston of the heater at the rear to the main heater, and connect the top side to the sub heater.

Height of the Fixing Inlet Guide

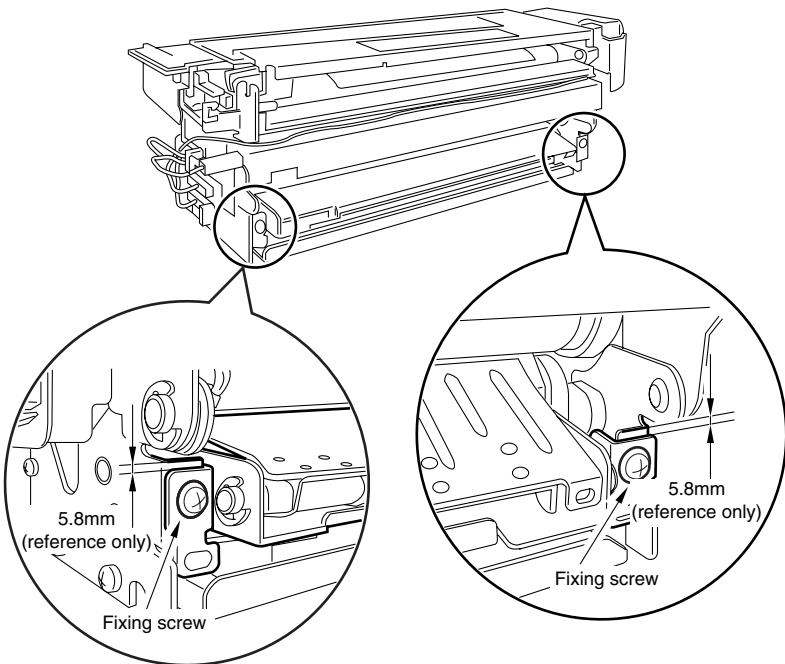

F06-205-01



Do not loosen the fixing screw on the inlet guide, as you will have to adjust the position of the inlet guide if you remove the inlet guide base. If you must loosen it, be sure to adjust the position of the inlet guide afterward by referring to the index on the fixing assembly.

2.5.2 Adjusting the Lower Roller Pressure (nip)

The nip width must be as indicated in T06-205-01; if not, adjust it using the pressure adjusting nut.

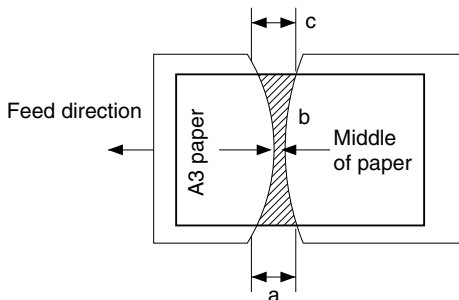

F06-205-02



a and c are points 10 mm from both edges of paper.

Dimension	Measure with upper and lower rollers fully heated
b	200 V: 9.0 ±0.5 mm, 208/230 V: 10.0 ±0.5 mm
a-c	0.5 mm or less

T06-205-01

a. Generating Output for Nip Width Measurement

Wait for 15 min after the copier ends its warm-up period; make 20 A4 copies, and measure the nip.

- 1) Place A3 copy paper in the manual feed tray.
- 2) Make the following selections in service mode to generate output:
COPIER>FUNCTION>FIXING>NIP-CHK.

The A3 paper will be picked up, and a copy like the one shown in F06-205-02 will be delivered.

2.6 Laser Exposure System

2.6.1 When Replacing the Laser Unit

See 4.3.1.b. “When Replacing the Laser Unit” in Chapter 2.

2.6.2 Checking the Laser Power

- 1) Check to make sure that the Data lamp in the control panel is OFF, and turn off the main power switch.
- 2) Disconnect the power plug from the power outlet.
- 3) Remove the copyboard glass.
- 4) Open the laser power checker slot cover [1].

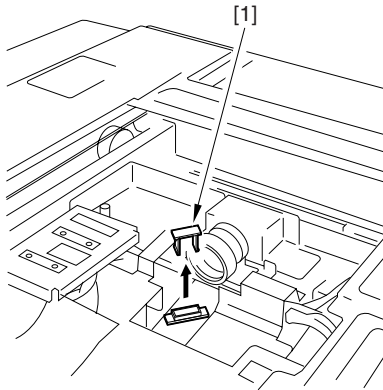

F06-206-01

- 5) Shift the switch of the laser power checker (FY9-40008) to '2'.

- 6) While orienting the laser power checker so that its light-receiving face [1] is as shown, fit it in.

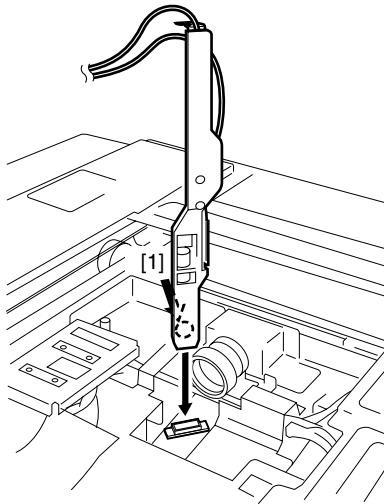

F06-206-02

- 7) Connect the probe lines of the laser power checker to a digital multimeter.

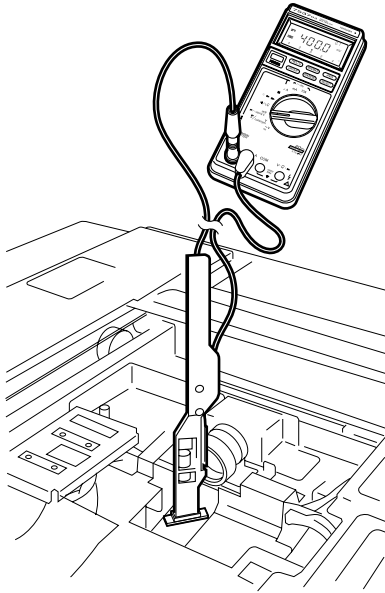

F06-206-03

- 8) Connect the power plug to the power outlet, and turn on the main power switch.
9) Make the following selections in service mode: COPIER>FUNCTION>LASER.
10) Select <POWER-A>, and press the OK key.
11) Check to see that the reading of the digital multimeter is 9 to 11 mV, indicating that the power of the laser A is correct.
12) Select <POWER-B>, and press the OK key.
13) Check to see that the reading of the digital multimeter is 9 to 11 mV, indicating that the power of the laser B is correct.

2.7 Electrical Parts-Related Items

2.7.1 Electrical Parts Requiring Work After Replacement

Parts name
Scanning lamp
CCD unit
Reader controller PCB
Main controller PCB
HDD unit
DC controller PCB
HV-DC PCB
Laser unit
Potential sensor/potential control PCB

2.7.2 When Replacing the Scanning Lamp

See 2.9 “Disassembly/Assembly” in Chapter 2.

2.7.3 When Replacing the CCD Unit

See 3.8.1.b. “When Replacing the CCD Unit” in Chapter 2.

2.7.4 When Replacing Reader Controller PCB

See 2.9 “Disassembly/Assembly” in Chapter 2.

2.7.5 When Replacing the Main Controller PCB

See 8.4.6.f. “When Replacing the Main Controller PCB” in Chapter 2.

2.7.6 When Replacing the HDD Unit

See 3.8.2.b. “When Replacing the Hard Disk” in Chapter 2.

2.7.7 When Replacing the DC Controller PCB

See 8.4.6.b. “When Replacing the DC Controller PCB” in Chapter 2.

2.7.8 When Replacing the HV-DC PCB

See 8.4.7.d. “When Replacing the HV-DC PCB” in Chapter 2.

2.7.9 When Replacing the Laser Unit

See 4.3.1.b. “When Replacing the Laser Unit” in Chapter 2.

2.7.10 When Replacing the Potential Sensor/Potential Control PCB

- 1) Check to make sure that the Execute/Memory lamp in the control panel is OFF, and turn off the main power switch.
- 2) Disconnect the power plug from the power outlet.



The machine remains powered after the main power switch is turned off as long as the power plug is connected to the power outlet. Be sure to disconnect the power plug from the power outlet.

- 3) Replace the potential sensor/potential control PCB.



The potential sensor and the potential control PCB are adjusted as a pair. Be sure to replace them at the same time.

- 4) Remove the developing assembly, and slide out the process unit.
- 5) Disconnect the connector [1] of the potential sensor.

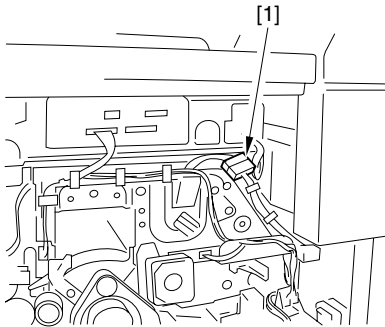

F06-207-01

- 6) Remove the 2 screws [1], and detach the potential sensor support plate [2].

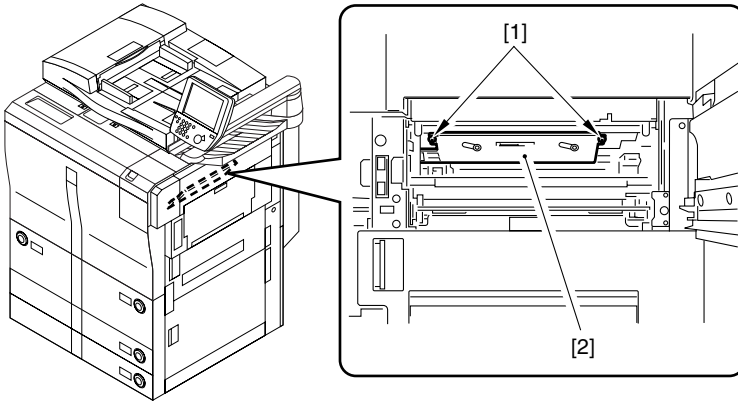

F06-207-02

- 7) Put back the developing assembly and the process unit.
8) Connect the connector [1] of the potential sensor.

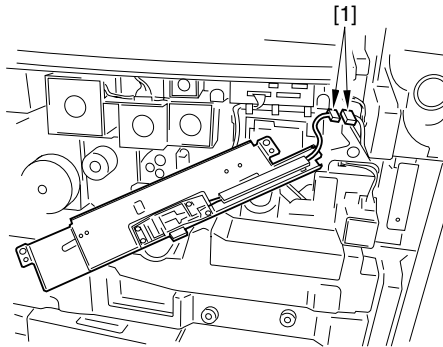

F06-207-03

- 9) Fit the potential checker electrode (FY9-3041) [2] to the potential sensor [1].

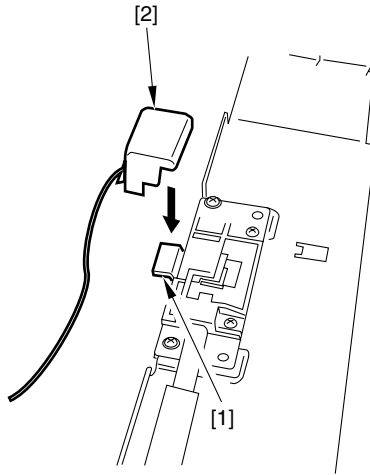

F06-207-04



When fitting the checker electrode to the potential sensor, make sure that the magnet of the checker electrode will not come into contact with the potential sensor cover.

- 10) Connect the cable [1] of the potential sensor checker electrode to the frame assembly (GND) [2] of the machine.



Never bring the clip into contact with the sensor cover. Be sure to fit it fully away from the sensor window.

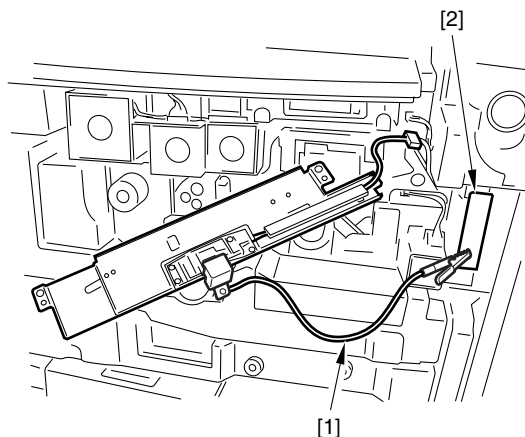

F06-207-05

- 11) Fit the door switch actuator in the door switch assembly.
- 12) Connect the power plug to the power outlet, and turn on the main power switch.
- 13) Execute the following in service mode: COPIER>FUNCTION>DPC>OFST.
- 14) Record the value of <OFST> on the service label.
- 15) Turn off the main power switch.
- 16) Disconnect the power plug from the power outlet.
- 17) Detach the potential sensor checker electrode.
- 18) Put back the potential sensor support plate.
- 19) Connect the power plug, and turn on the main power switch.

2.7.11 Checking the Surface Potential Control System

a. Outline

If image faults occur, it is important to find out whether the cause is in the latent static image formation block (including the photosensitive drum and the potential control system) or it is in the developing/transfer system, requiring a check on the surface potential. (You can check the surface potential in service mode.)

b. Disabling the Auto Control Mechanisms

As a way of checking the mechanisms used for corona current control, lamp intensity control, or developing bias control, you may disable the auto control mechanisms (hereafter, non-auto control mode).

As a first-aid measure when a fault exists in the auto control mechanism, you may use non-auto control mode; keep in mind that all outputs in non-auto control mode are fixed to standard values.

1. Procedure

- 1) Make the following selections in service mode, and enter '0':
COPIER>OPTION>BODY>PO-CNT.
- 2) Press the Reset key twice.



In non-auto control mode, all settings used for coronal current control, intensity control, developing bias control will be set to standard settings stored in ROM.

2. Making Use of Non-Auto Control Mode

If a fault occurs in images, use the mode to find out if the cause is on the input side or output side of the microprocessor on the DC controller PCB.

In non-auto control mode, if the fault is corrected somewhat, you may suspect the potential measurement unit or the DC controller PCB.

c. Zero-Level Check

One way of finding out if the surface potential control circuit is good or not is to use a zero-level check.



A zero-level check is made to see if the microprocessor registers 0 V when the surface potential of the drum is 0 V.

Using the result of the check, you can find out if the microprocessor on the DC controller PCB or the measurement unit is good or not; a zero-level check may take either of the following two methods:

1. Method 1
 - 1) Turn off the power switch.
 - 2) Short the connectors J522-1 and -2 on the DC controller PCB with a jumper wire, and disconnect the connector J3 of the potential control PCB.

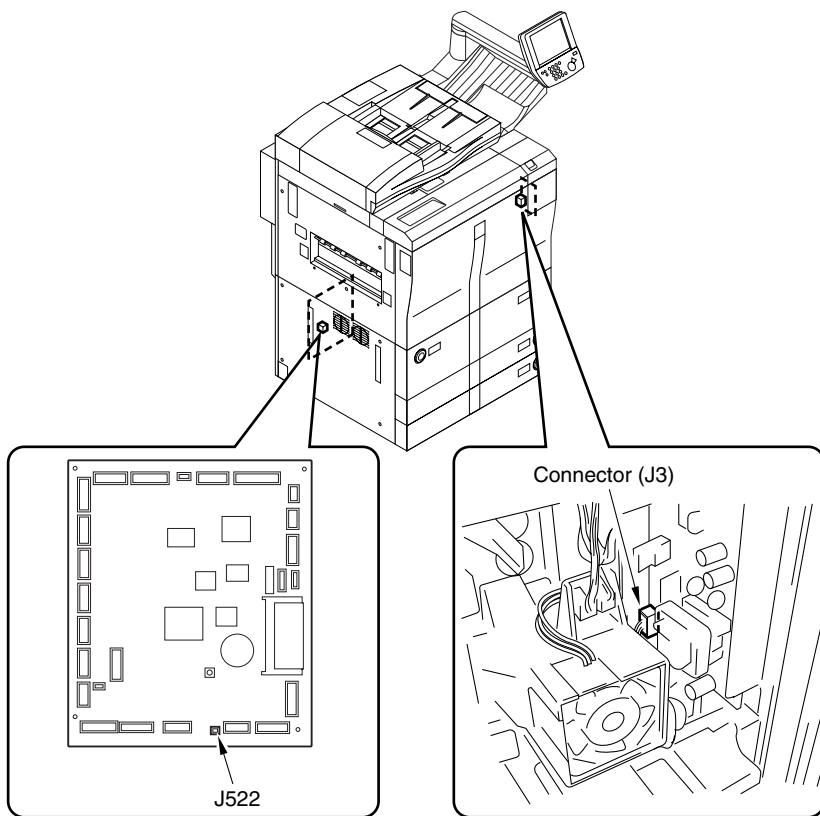

F06-207-06

- 3) Fit the door switch actuator into the door switch assembly, and turn on the power switch.
- 4) Make the following selections in service mode, and check to see if the reading is between 0 and 30 during initial rotation: COPIER>DISPLAY>DPOT>DPOT-K.

If the reading is not as indicated, you may suspect a fault in the DC controller PCB.

- 5) Turn off the power switch, and detach the door switch actuator.
 - 6) Detach the jumper wire from the DC controller PCB.
 - 7) Connect the connector to J3 of the potential control PCB.
 - 8) Turn on the power switch.
2. Method 2
- 1) Turn off the power switch.
 - 2) Remove the developing assembly, and slide out the process unit.
 - 3) Disconnect the connector [1] of the potential sensor.

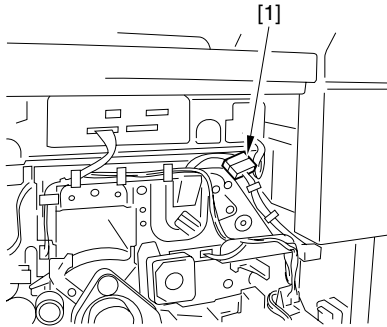

F06-207-07

- 4) Remove the 2 screws [1], and detach the potential sensor support plate [2].

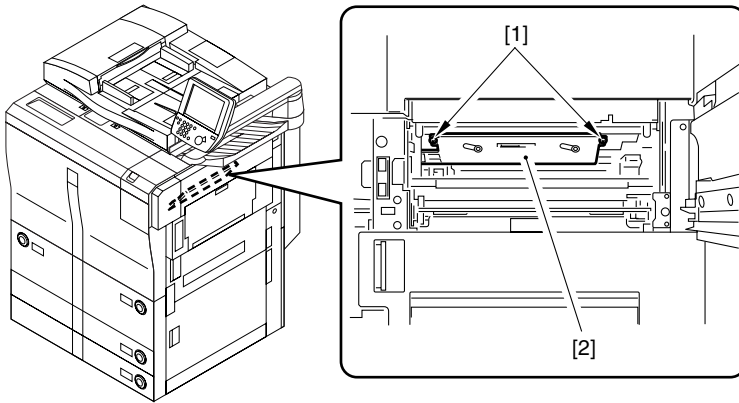

F06-207-08

- 5) Put back the developing assembly and the process unit.
6) Connect the connector [1] of the potential sensor.

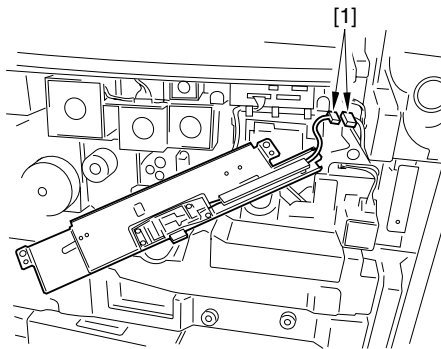

F06-207-09

- 7) Fit the potential sensor checker electrode (FY9-3041) [2] to the potential sensor [1].



When fitting the checker electrode to the potential sensor, be sure that the magnet of the checker electrode will not come into contact with the potential sensor cover.

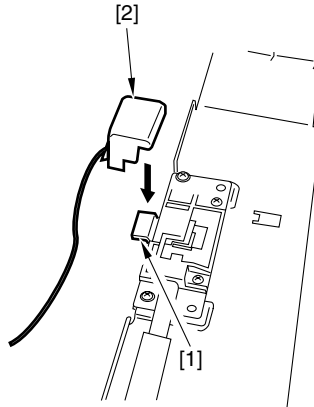

F06-207-10

- 8) Connect the cable [1] of the potential sensor checker electrode to the frame (GND) [2] of the machine.



Never bring the clip into contact with the sensor cover. Be sure to keep it fully away from the sensor window.

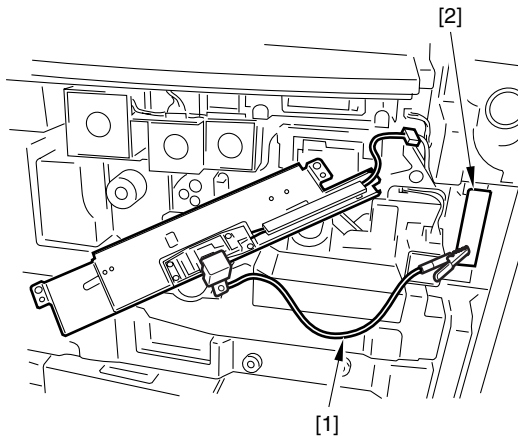

F06-207-11

- 9) Fit the door switch actuator into the door switch assembly.
- 10) Turn on the power switch.



Once you have turned on the power switch, do not touch the potential sensor assembly.

- 11) Make the following selections in service mode, and check to make sure that the reading is between 0 and 30 during initial rotation: COPIER>DISPLAY>DPOT>DPOT-K.



-
- 1. If the reading is as indicated in Method 1 but is not in Method 2, suspect dirt on the sensor or a fault in the potential measurement unit.
 - 2. If the reading is as indicated in both Method 1 and Method 2, assume that the signal path and the operation from the potential sensor unit to the microprocessor on the DC controller PCB are normal.
-

- 12) Turn off the power switch.
- 13) Remove the potential sensor checker electrode.
- 14) Mount the potential sensor support plate.
- 15) Turn on the power switch.

2.8 Potential Control System Conversion Table

Control (V)	Primary (μ A)	Developing bias (V)	Pre-transfer (μ A)	Transfer (μ A)	Separation (μ A)
3.00	1600	0	+0	+0	+0
3.05	1590	3	+2	-4	+5
3.10	1580	7	+4	-8	+10
3.15	1570	11	+6	-12	+15
3.20	1560	15	+8	-16	+20
3.25	1550	18	+10	-20	+25
3.30	1540	22	+12	-24	+30
3.35	1530	26	+14	-28	+35
3.40	1520	30	+15	-32	+40
3.45	1510	33	+17	-36	+45
3.50	1500	37	+19	-40	+50
3.55	1490	41	+21	-44	+55
3.60	1480	45	+23	-48	+60
3.65	1470	48	+25	-52	+65
3.70	1460	52	+27	-56	+70
3.75	1450	56	+29	-60	+75
3.80	1440	60	+30	-65	+80
3.85	1430	63	+32	-69	+85
3.90	1420	67	+34	-73	+90
3.95	1410	71	+36	-77	+95
4.00	1400	75	+38	-81	+100
4.05	1390	78	+40	-85	+105
4.10	1380	82	+42	-89	+110
4.15	1370	86	+44	-93	+115
4.20	1360	90	+45	-97	+120
4.25	1350	93	+47	-101	+125
4.30	1340	97	+49	-105	+130
4.35	1330	101	+51	-109	+135
4.40	1320	105	+53	-113	+140
4.45	1310	108	+55	-117	+145
4.50	1300	112	+57	-121	+150
4.55	1290	116	+59	-125	+155
4.60	1280	119	+60	-129	+160
4.65	1270	123	+62	-134	+165
4.70	1260	127	+64	-138	+170
4.75	1250	131	+66	-142	+175
4.80	1240	134	+68	-146	+180
4.85	1230	138	+70	-150	+185
4.90	1220	142	+72	-154	+190
4.95	1210	146	+74	-158	+195

T06-208-01

Control (V)	Primary (μ A)	Developing bias (V)	Pre-transfer (μ A)	Transfer (μ A)	Separation (μ A)
5.00	1200	150	+75	-162	+200
5.05	1190	153	+77	-166	+205
5.10	1180	157	+79	-170	+210
5.15	1170	161	+81	-174	+215
5.20	1160	165	+83	-178	+220
5.25	1150	168	+85	-182	+225
5.30	1140	172	+87	-186	+230
5.35	1130	176	+89	-190	+235
5.40	1120	180	+90	-195	+240
5.45	1110	183	+92	-199	+245
5.50	1100	187	+94	-203	+250
5.55	1090	191	+96	-207	+255
5.60	1080	195	+98	-211	+260
5.65	1070	198	+100	-215	+265
5.70	1060	202	+102	-219	+270
5.75	1050	206	+104	-223	+275
5.80	1040	210	+105	-227	+280
5.85	1030	213	+107	-231	+285
5.90	1020	217	+109	-235	+290
5.95	1010	221	+111	-239	+295
6.00	1000	225	+113	-243	+300
6.05	990	228	+115	-247	+305
6.10	980	232	+117	-251	+310
6.15	970	236	+119	-255	+315
6.20	960	240	+120	-260	+320
6.25	950	243	+122	-264	+325
6.30	940	247	+124	-268	+330
6.35	930	251	+126	-272	+335
6.40	920	255	+128	-276	+340
6.45	910	258	+130	-280	+345
6.50	900	262	+132	-284	+350
6.55	890	266	+134	-288	+355
6.60	880	269	+135	-292	+360
6.65	870	273	+137	-296	+365
6.70	860	277	+139	-300	+370
6.75	850	281	+141	-304	+375
6.80	840	285	+143	-308	+380
6.85	830	288	+145	-312	+385
6.90	820	292	+147	-316	+390
6.95	810	296	+149	-320	+395
7.00	800	300	+150	-325	+400

T06-208-02

Control (V)	Primary (μ A)	Developing bias (V)	Pre-transfer (μ A)	Transfer (μ A)	Separation (μ A)
7.05	790	303	+152	-329	+405
7.10	780	307	+154	-333	+410
7.15	770	311	+156	-337	+415
7.20	760	315	+158	-341	+420
7.25	750	318	+160	-345	+425
7.30	740	322	+162	-349	+430
7.35	730	326	+164	-353	+435
7.40	720	330	+165	-357	+440
7.45	710	333	+167	-361	+445
7.50	700	337	+169	-365	+450
7.55	690	341	+171	-369	+455
7.60	680	345	+173	-373	+460
7.65	670	348	+175	-377	+465
7.70	660	352	+177	-381	+470
7.75	650	356	+179	-385	+475
7.80	640	360	+180	-390	+480
7.85	630	363	+182	-394	+485
7.90	620	367	+184	-398	+490
7.95	610	371	+186	-402	+495
8.00	600	375	+188	-406	+500
8.05	590	378	+190	-410	+505
8.10	580	382	+192	-414	+510
8.15	570	386	+194	-418	+515
8.20	560	390	+195	-422	+520
8.25	550	393	+197	-426	+525
8.30	540	397	+199	-430	+530
8.35	530	401	+201	-434	+535
8.40	520	405	+203	-438	+540
8.45	510	408	+205	-442	+545
8.50	500	412	+207	-446	+550
8.55	490	416	+209	-450	+555
8.60	480	419	+210	-454	+560
8.65	470	423	+212	-459	+565
8.70	460	427	+214	-463	+570
8.75	450	431	+216	-467	+575
8.80	440	434	+218	-471	+580
8.85	430	438	+220	-475	+585
8.90	420	442	+222	-479	+590
8.95	410	446	+224	-483	+595
9.00	400	450	+225	-487	+600
9.05	390	453	+227	-491	+605

T06-208-03

Control (V)	Primary (μ A)	Developing bias (V)	Pre-transfer (μ A)	Transfer (μ A)	Separation (μ A)
9.10	380	457	+229	-495	+610
9.15	370	461	+231	-499	+615
9.20	360	465	+233	-503	+620
9.25	350	468	+235	-507	+625
9.30	340	472	+237	-511	+630
9.35	330	476	+239	-515	+635
9.40	320	480	+240	-520	+640
9.45	310	483	+242	-524	+645
9.50	300	487	+244	-528	+650
9.55	290	491	+246	-532	+655
9.60	280	495	+248	-536	+660
9.65	270	498	+250	-540	+665
9.70	260	502	+252	-544	+670
9.75	250	506	+254	-548	+675
9.80	240	510	+255	-552	+680
9.85	230	513	+257	-556	+685
9.90	220	517	+259	-560	+690
9.95	210	521	+261	-564	+695
10.00	200	525	+263	-568	+700
10.05	190	528	+265	-572	+705
10.10	180	532	+267	-576	+710
10.15	170	536	+269	-580	+715
10.20	160	540	+270	-585	+720
10.25	150	543	+272	-589	+725
10.30	140	547	+274	-593	+730
10.35	130	551	+276	-597	+735
10.40	120	555	+278	-601	+740
10.45	110	558	+280	-605	+745
10.50	100	562	+282	-609	+750
10.55	90	566	+284	-613	+755
10.60	80	570	+285	-617	+760
10.65	70	573	+287	-621	+765
10.70	60	577	+289	-625	+770
10.75	50	581	+291	-629	+775
10.80	40	585	+293	-633	+780
10.85	30	588	+295	-637	+785
10.90	20	592	+297	-641	+790
10.95	10	596	+299	-645	+795
11.00	0	600	+300	-650	+800

T06-208-04

2.9 Checking the Environment Sensor

1) Checking the Environment Sensor

Make the following selections in service mode, and check and record the temperature/humidity indicated on the screen in the control panel: COPIER>DISPLAY>ANALOG.
Data A

'RTMP' °C data A1

'RHUM' % data A2

- 2) Press the Rest key twice to turn off the power switch.
- 3) Remove the environment sensor, and fit the environment sensor jig (FY9-3014) in its place.
- 4) Turn on the power switch, and leave the machine alone for 5 min.
- 5) Make the following selections in service mode, and check and record the temperature/humidity indicated on the screen in the control panel: COPIER>DISPLAY>ANALOG:
Data B
'RTMP' °C data B1
'RHUM' % data B2
- 6) Compare data A and data B.
 - difference between data A 1 and data B1 is 0 ± 5
 - difference between data A2 and data B2 is 0 ± 20If the difference between data A and data B is outside the range, replace the environment sensor.
- 7) Press the Reset key twice, and turn off the power switch.
- 8) Detach the environment sensor jig, and fit the environment sensor.
- 9) Put back all covers.



The environment sensor jig (FY9-301) is precisely adjusted at the factory.
Be sure to keep it in an air-tight case with a drying agent.

2.10 Checking the Photointerrupters

The machine allows the use of a conventional meter or its service mode for checks on its photointerrupters:

a. Using a Meter

- 1) Set the meter range to 30 VDC.
- 2) Connect the - probe of the meter to GND of the DC controller PCB.
- 3) Connect the + probe of the meter to the terminal (DC controller PCB) indicated in the table that follows.
- 4) Make checks as indicated.

b. Using Service Mode

- 1) Start service mode (CPEOR>I/O), and check the corresponding address.



Take full care. The sensor goes on and off, at times causing the motors and the like to operate.

Sensor	Connector No. I/O address		Checks	I/O	Volt- age
PS1 Scanner HP sensor	J1110-A1	Move the scanner by hand in standby.	The light-blocking plate is at PS1.	1	5 V
	-		The light-blocking plate is not at PS1.	0	0 V
PS3 Image leading edge sensor	J1110-A4	Move the scanner by hand in standby.	The light-blocking plate is at PS3.	1	5 V
	-		The light-blocking plate is not at PS3.	0	0 V
PS4 Copyboard cover open/ closed sensor	J1110-B9	Move the copyboard cover by hand in standby.	The cover is closed.	1	5 V
	P001-4		The cover is open.	0	0 V
PS5 Registration paper sensor	J509-A2	Put paper over PS5 in standby.	Paper is not over PS5.	1	5 V
	P010-11		Paper is over PS5.	0	0 V
PS6 Fixing claw jam sensor	J508-B15	Put paper over PS6 in standby.	Paper is not over PS6.	0	0 V
	P010-15		Paper is over PS6.	1	5 V
PS7 Fixing web length sensor	J508-B2	Move the detecting lever of PS7 by hand in standby.	The web is present.	0	0 V
	P003-3		The web is absent.	1	5 V
PS8 Fixing web length warning sensor	J508-B5	Move the detecting lever of PS8 in standby.	The No Web warning is present.	1	5 V
	P003-4		The No Web warning is absent.	0	0 V
PS9 Inside delivery sensor	J508-A2	Put paper over the detect- ing lever assembly of PS9 in standby.	Paper is put.	1	5 V
	P010-12		Paper is removed.	0	0 V
PS10 Outside deliv- ery sensor	J508-A8	Put paper over the detect- ing lever of PS10 in standby.	Paper is put.	1	5 V
	P010-13		Paper is removed.	0	0 V
PS11 Fixing/feeding unit outlet sen- sor	J508-A11	Put paper over the detect- ing lever assembly of PS11 in standby.	Paper is put.	1	5 V
	P010-14		Paper is removed.	0	0 V
PS12 Duplexing re- versal sensor	J519-B10	Put paper over the detect- ing lever of PS12 in standby.	Paper is put.	0	0 V
	P002-1		Paper is removed.	1	5 V
PS14 Pre-confluence sensor	J519-B12	Put paper over the detect- ing lever assembly of PS14 in standby.	Paper is put.	1	5 V
	P002-3		Paper is not put.	0	0 V

T06-210-01

Sensor	Connector No. I/O address	Checks	I/O	Voltage
PS15 Post-confluence sensor	J519-B13	Put paper over the detecting lever assembly of PS15 in standby.	Paper is put.	1 5 V
	P002-4		Paper is not put.	0 0 V
PS17 Manual feed tray paper sensor	J510-B9	Move the rear partitioning plate by hand in standby.	Paper is put.	1 5 V
	P004-12		Paper is not put.	0 0 V
PS18 Horizontal registration sensor	J519-B14	Put paper over PS18 in standby.	Paper is over PS18.	1 5 V
	P025-7		Paper is not over PS18.	0 0 V
PS19 Waste toner case full sensor	J514-A2	Put paper over the detecting lever of PS19 in standby.	Paper is put.	1 5 V
	P003-7		Paper is removed.	0 0 V
PS21 Right deck lifter sensor	J511-A6	Move the detecting lever by hand in standby.	The light-blocking plate is at PS21.	1 5 V
	P004-0		The light-blocking plate is not at PS21.	0 0 V
PS22 Right deck paper sensor	J511-A9	Move the detecting lever by hand in standby.	The light-blocking plate is at PS22.	1 5 V
	P004-8		The light-blocking plate is not at PS22.	0 0 V
PS23 Right deck open/closed sensor	J511-B2	Move the detecting lever by hand in standby.	The light-blocking plate is at PS23.	1 5 V
	P005-4		The light-blocking plate is not at PS23.	0 0 V
PS24 Right deck limit sensor	J511-B13	Move the detecting lever by hand in standby.	The light-blocking plate is at PS24.	1 5 V
	P004-14		The light-blocking plate is not at PS24.	0 0 V
PS28 Fixing/feeding unit releasing lever sensor	J509-B9	Move the detecting lever by hand in standby.	The light-blocking plate is at PS28.	1 5 V
	P005-14		The light-blocking plate is not at PS28.	0 0 V
PS31 Left deck lifter sensor	J518-A2	Move the detecting lever by hand in standby.	The light-detecting plate is at PS31.	1 5 V
	P004-1		The light-blocking plate is not at PS31.	0 0 V

T06-210-02

Sensor	Connector No. I/O address		Checks	I/O	Volt- age
PS32 Left deck paper sensor	J518-A5	Move the detecting lever by hand in standby.	The light-blocking plate is at PS32.	1	5 V
	P004-9		The light-blocking plate is not at PS32.	0	0 V
PS33 Left deck open/closed sensor	J518-B2	Move the detecting lever by hand in standby.	The light-blocking plate is at PS33.	1	5 V
	P005-5		The light-blocking plate is not at PS33.	0	0 V
PS34 Left deck limit sensor	J518-B5	Move the detecting lever by hand in standby.	The light-blocking plate is at PS34.	1	5 V
	P004-15		The light-blocking plate is not at PS34.	0	0 V
PS35 Manual feed inlet sensor	J510-B3	Move the detecting lever by hand in standby.	The light-blocking plate is at PS35.	1	5 V
	P010-10		The light-blocking plate is not at PS35.	0	0 V
PS38 Cassette 3 lifter sensor	J515-A6	Move the detecting lever by hand in standby.	The light-blocking plate is at PS38.	1	5 V
	P004-2		The light-blocking plate is not at PS38.	0	0 V
PS39 Cassette 3 pa- per sensor	J515-A9	Move the detecting lever by hand in standby.	The light-blocking plate is at PS39.	-	5 V
	P004-10		The light-blocking plate is not at PS39.	-	0 V
PS40 Cassette 3 open/closed sensor	J515-B2	Move the detecting lever by hand in standby.	The light-blocking plate is at PS40.	1	5 V
	P005-6		The light-blocking plate is not at PS40.	0	0 V
PS43 Cassette 4 lifter sensor	J517-A6	Move the detecting lever by hand in standby.	The light-blocking plate is at PS43.	1	5 V
	P004-3		The light-blocking plate is not at PS43.	0	0 V
PS44 Cassette 4 pa- per sensor	J517-A9	Move the detecting lever by hand in standby.	The light-blocking plate is at PS44.	1	5 V
	P004-11		The light-blocking plate is not at PS44.	0	0 V
PS45 Cassette 4 open/closed sensor	J517-B2	Move the detecting lever by hand in standby.	The light-blocking plate is at PS45.	1	5 V
	P005-7		The light-blocking plate is not at PS45.	0	0 V

T06-210-03

Sensor	Connector No. I/O address		Checks	I/O	Volt- age
PS47 Vertical path 1 paper sensor	J502-B5	Move the detecting lever by hand in standby.	The light-blocking plate is at PS47.	1	5 V
	P010-4		The light-blocking plate is not a PS47.	0	0 V
PS48 Right lower cover open/ closed sensor	J516-A2	Move the detecting lever by hand in standby.	The light-blocking plate is at PS48.	1	5 V
	P005-9		The light-blocking plate is not at PS48.	0	0 V
PS49 Vertical path 2 paper sensor	J516-B9	Move the detecting lever by hand in standby.	The light-blocking plate is at PS49.	1	5 V
	P010-5		The light-blocking plate is not at PS49.	0	0 V
PS51 Right deck pa- per level middle sensor	J513-B9	Move the detecting lever by hand in standby.	The light-blocking plate is at PS51.	1	5 V
	P004-4		The light-blocking plate is not at PS51.	0	0 V
PS52 Right deck pa- per level high sensor	J513-B12	Move the detecting lever by hand in standby.	The light-blocking plate is at PS52.	-	5 V
	P004-5		The light-blocking plate is not at PS52.	-	0 V
PS54 Left deck paper level middle sensor	J514-B9	Move the detecting lever by hand in standby.	The light-blocking plate at PS54.	1	5 V
	P004-6		The light-blocking plate is not at PS54.	0	0 V
PS55 Left deck paper level high sen- sor	J514-B12	Move the detecting lever by hand in standby.	The light-blocking plate is at PS55.	-	5 V
	P004-7		The light-blocking plate is not at PS55.	-	0 V
PS56 Manual feed tray cover open/closed sensor	J502-A2	Move the detecting lever by hand in standby.	The light-blocking plate is at PS56.	1	5 V
	P005-10		The light-blocking plate is not at PS56.	0	0 V
PS58 Right upper cover open/ closed sensor	J502-B2	Move the detecting lever by hand in standby.	The light-blocking plate is at PS58.	1	5 V
	P005-8		The light-blocking plate is not at PS58.	0	0 V

T06-210-04

Sensor	Connector No. I/O address		Checks	I/O	Voltage
PS59	J512-B2	Move the detecting lever by hand in standby.	The light-blocking plate is at PS59.	1	5 V
Toner cartridge cover open/ closed sensor	P005-12		The light-blocking plate is not at PS59	0	0 V
PS61	J519-B11	Put paper over the detecting assembly of PS61 in standby.	Paper is put.	1	5 V
Duplex output sensor	P002-2		Paper is removed.	0	0 V

T06-210-05

2.11 Checking the Optical Sensors

Sensor	Connector No. I/O address	Checks	I/O	Voltage
PS20 Right deck pickup sensor	J511-B6 P010-0	Put paper over PS20 in standby.	Paper is at PS20. Paper is not at PS20.	1 5 V 0 0 V
PS25 Left deck pickup sensor	J518-A9 P010-1	Put paper over PS25 in standby.	Paper is at PS25. Paper is not at PS25.	1 5 V 0 0 V
PS26 Left deck feed sensor	J519-B16 P010-9	Put paper over PS26 in standby.	Paper is at PS26. Paper is not at PS26.	1 5 V 0 0 V
PS27 Right deck feed sensor	J511-B10 P010-8	Put paper over PS27 in standby.	Paper is at PS27. Paper is not at PS27.	1 5 V 0 0 V
PS37 Cassette 3 pickup sensor	J515-B6 P010-2	Put paper over PS37 in standby.	Paper is at PS37. Paper is not at PS37.	- 5 V - 0 V
PS41 Vertical path 3 paper sensor	J515-B10 P010-6	Put paper over PS41 in standby.	Paper is at PS41. Paper is not at PS41.	1 5 V 0 0 V
PS42 Cassette 4 pickup sensor	J517-B6 P010-3	Put paper over PS42 in standby.	Paper is at PS42. Paper is not at PS42.	1 5 V 0 0 V
PS46 Vertical path 4 paper sensor	J517-B10 P010-7	Put paper over PS46 in standby.	Paper is at PS46. Paper is not at PS46.	1 5 V 0 0 V
PS60 Image write start sensor	J503-B8 P002-5	Put paper over PS60 in standby.	Paper is at PS60. Paper is not at PS60.	1 5 V 0 0 V

T06-211-01

3 Troubleshooting Image Faults

3.1 Making Initial Checks

3.1.1 Checking the Side of Installation

Check the site of installation against the following requirements:

- a. The voltage of the power supply must be as rated ($\pm 10\%$). The power plug must remain connected day and night.
- b. The site must not be subject to high temperature/humidity (near a water faucet, water boiler, humidifier). The machine must not be installed in a cold place or in an area near a source of fire or subject to dust.
- c. The site must not be subject to ammonium gas.
- d. The site must not be subject to direct rays of the sun. As necessary, curtains must be provided.
- e. The site must be well ventilated.
- f. The machine must be kept level.
- g. The machine must remain powered throughout the night.

3.1.2 Checking the Originals

Check the originals to find out whether the problem is caused by the originals used or is in the machine:

- a. The copy density setting is optimum at 5 ± 1 .
- b. If the original has a reddish background, copies can suffer poor contrast.



Red sheets, slips, and the like.

- c. The density of the original can have the following effects:



if the original is a diazo copy or is rather transparent, copies can be mistaken as being “foggy.”
 if the original is prepared in pencil, copies can be mistaken as being “too light.”

3.1.3 Checking the Copyboard Cover, Copyboard Glass, and Standard White Plate

Check the copyboard cover, copyboard glass, and standard white plate for dirt or scratches. If dirt is found, clean it with a solution of mild detergent or alcohol; if a scratch is found, on the other hand, replace it.

3.1.4 Checking the Charging Assemblies

- a. Check the charging assemblies for dirt and a faulty charging wire.
- b. Clean the charging wire and the shielding plate of the charging assemblies. (If dirt cannot be removed, replace it.)
- c. Check the type and height of the charging wire.
- d. Check to make sure that the charging assemblies are firmly fitted.
- e. Check the charging wire spring for rusting.
- f. Check the charging wire cleaning pad (of each charging assembly) for displacement.

3.1.5 Checking the Developing Assembly

- a. Check to make sure that the rolls on both ends of the developing assembly are in contact with the drum.
- b. Check to make sure that the surface of the developing cylinder is coated with an even layer of toner.
- c. Check the connectors between the developing assembly and the machine for connection.
- d. Check to make sure that the slide switch (SW101) of the HV-DC PCB is in UP position.
- e. Check to make sure that the 4th page <DEV-SLO> of the following in service mode in '2': COPIER>OPTION>BODY.

3.1.6 Checking the Paper

- a. Check to see if the paper is a type recommended by Canon.
- b. Check to see if the paper is moist. Try paper fresh out of package.

3.1.7 Checking the Periodically Replaced Parts

Check with the Periodical Servicing Chart and the Periodically Replaced Parts Table, and replace those parts that have reached the end of their lives.

3.1.8 Others

In winter, bringing a machine from a cold to warm place can cause the inside of the machine to develop condensation, leading to various problems.



-
- a. Condensation in the scanning system (glass, mirrors, lenses) will produce darker images.
 - b. Condensation in the charging system will cause electrical leakage.
 - c. Condensation on the pickup/feeding guide will cause feeding faults.
- If condensation is found, dry wipe the part or leave the machine alone and powered for 60 min.
-



If the density is uneven (different between front and rear) or the image is too light or is foggy, perform the “Image Adjustment Basic Procedure” in advance.

Blank page

3.2 Sample Faulty Images

Note: These samples have been prepared artificially. They may appear somewhat different from actual faulty images because they have been generated using A3 copies made of the NA3 Test Sheet and reducing them to about 19%.

3.3 Troubleshooting Image Faults

3.3.1 The output is too light (halftone area)

-----	<p>1) Perform the Image Adjustment Basic Procedure. Is the problem corrected? YES: End.</p>
Scanner (dirt)	<p>2) Does the problem occur only in copy images? YES: The cause is between scanner and CCD. Perform the following once again: [1] Check the standard white plate for dirt. [2] Execute the following in service mode: COPIER>FUNCTION>CDD>CCD-ADJ.</p>
AE adjustment	<p>3) Make copies in AE mode. Is the density normal? YES: End.</p>
Developing assembly	<p>4) Are the rolls of the developing assembly in firm contact with the drum? NO: Check the mounting of the developing assembly locking mechanism. YES: Check to see if the coating of toner on the developing cylinder is even.</p>
Image processing	<p>5) Is the setting of the following in service mode too low: COPIER>ADJUST>DENS>DEN>ADJ? YES: Set it to '5'.</p> <p>6) Check to see if the slide switch (SW101) of the HV-DC PCB is in UP position.</p>

3.3.2 The output is too light (solid black area)

3.3.3 The output is too light (overall, considerably)

Copy paper	<p>1) Try paper fresh out of package. Is the problem corrected? YES: 1. The paper may be moist. Advise the user on the correct method of storing paper. 2. Advise the user that using non-recommended paper may not bring about the best results.</p>
-----	<p>2) Perform the Image Adjustment Basic Procedure. Is the problem corrected? YES: End.</p>
-----	<p>3) Turn off the power switch in the middle of copying, and open the front cover. Is the toner image on the surface of the photosensitive drum before transfer more or less normal? NO: The cause is before transfer. Go to step 8.</p>
Transfer (fault)	<p>4) Is the transfer/separation charging assembly fully fitted? NO: Fit the charging assembly fully.</p> <p>5) Make copies by varying the setting of the following in service mode between '1' and '3' to suit the environment: COPIER>OPTION>BODY>FUZZY. Is the problem corrected? YES: End. (The problem is caused by the environment.) NO: Set the settings of 'FUZZY' back to '1', and go to the next step.</p>
Transfer (faulty)	
Transfer guide	<p>6) Measure the resistance between the transfer guide and the base (metal portion) for the feeding assembly using a meter. Is the electrical resistance 0 Ω? YES: Check to find out if the transfer guide is in contact with a metal portion (e.g., side plate of the feeding assembly).</p>
DC controller PCB	<p>NO: Check the high-voltage transformer (HVT) and the DC controller PCB.</p>

Development (faulty)

Developing assembly (position)

- 7) Is the developing assembly firmly fitted? Are the rolls of the developing assembly in firm contact with the photosensitive drum?**
-

Pre-transfer charging assembly

- 8) Is the pre-transfer charging assembly fully fitted?**

NO: Fit the charging assembly fully.

Potential control, Photosensitive drum

Developing bias control

- 9) Turn off and then on the power switch. Then, check the setting of the following in service mode: COPIER>DISPLAY>DPOT>VL1M, VDM. Is it as follows?**

VL1M: 50 to 90

VDM: 390 to 460

NO: Check the power supply system; if normal, replace the photosensitive drum.

YES: Check the developing bias control system.

- 10) Check to see that the slide switch (SW101) of the HV-DC PCB is in UP position.**

3.3.4 The output has uneven density (darker at the front)

3.3.5 The output has uneven density (lighter at the front)

-----	<p>1) Perform the Image Adjustment Basic Procedure. Is the problem corrected? YES: End.</p>
Development assembly (position)	<p>2) Are the rolls of the developing assembly in firm contact with the photosensitive drum? NO: Check the developing assembly locking unit.</p>
Scanner (dirt)	<p>3) Clean the scanning lamp, reflecting plate, side reflecting plate, mirrors, lenses, and dust-proofing glass. Is the problem corrected?</p>
Pre-exposure lamp	<p>4) Does the pre-exposure lamp ON evenly during copying operation? NO: [1] Replace the pre-exposure lamp. [2] Replace the DC controller PCB.</p>
Developing assembly Charging assembly, Copy paper	<p>5) Is the developing cylinder coated with an even layer of toner? NO: [1] Clean the edge of the blade of the developing assembly (by dry wiping). [2] Clean the surface of the developing cylinder. [3] Check to see if the toner inside the developing assembly is level or not. YES: [1] Clean all charging wires once again, and check the position of each once again. [2] Try replacing the copy paper. [3] Check the nip of the fixing roller.</p>

3.3.6 The output is foggy (overall)

-----	<p>1) Perform the Image Adjustment Basic Procedure. Is the problem corrected? YES: End.</p>
Scanner (dirt)	<p>2) Does the problem occur only in copy images? YES: The cause is between scanner and CCD. Perform the following: [1] Check the scanning lamp for dirt and the end of its life. [2] Check the reflecting plate, mirrors, lenses, and standard white plate for dirt.</p>
High-voltage DC PCB (settings)	<p>3) Is the switch SW101 on the high-voltage PCB set to UP position? NO: Set it to UP position.</p>
Potential control system	<p>4) Set the following in service mode '0' to turn off potential control: COPIER>OPTION>BODY>PO-CNT. Is the problem corrected? YES: The cause is in the potential control system. Make checks as instructed for checking the surface potential control system (2.7.12).</p>
Cleaner assembly	<p>5) Is the cleaning blade mounted correctly? NO: Mount the cleaning blade correctly.</p>
Pre-exposure lamp, DC controller PCB	<p>6) Does the pre-exposure lamp remain ON during copying? NO: [1] Replace the pre-exposure lamp. [2] Replace the DC controller PCB.</p>
Developing roll, Developing cylinder	<p>7) Is the developing roll worn? YES: Replace the developing roll. NO: Replace the developing cylinder.</p>
Developing bias (control)	<p>8) Is the setting of the following in service mode high: COPIER>ADJUST>V-CONT>DE-OFT, OHP-OFST? YES: Try decreasing the setting.</p>
Developing cylinder speed control	<p>9) Is the setting of the following in service mode '2': COPIER>OPTION>BODY>DEVL-SLOW? NO: Set it to '2'.</p>

3.3.7 The output has vertical fogging

3.3.8 The output has black lines (vertical, fuzzy, thick)

Scanner (dirt)	<p>1) Does the problem occur only in copy images? YES: The cause is between scanner and CCD. Perform the following:</p> <ul style="list-style-type: none"> [1] Check the scanning lamp for print and the end of its life. [2] Check the reflecting plate, mirrors, lenses, and standard white plate for dirt.
Potential control system	<p>2) Set the following in service mode to '0' to turn off potential control: COPIER>OPTION>BODY>PO-CNT. Is the problem corrected? YES: the cause is in the potential control system. Make checks as instructed for checking the potential control system in Chapter 2 (standards and adjustments).</p>
Primary charging assembly	<p>3) Clean the primary charging wire, grid wire, and shielding plate. Is the problem corrected? YES: End.</p>
Pre-exposure lamp	<p>4) Clean the pre-exposure lamp. Is the problem corrected? YES: End.</p>
Fixing assembly	<p>5) Using the door switch actuator, make a copy with the front cover open. Turn off the power switch when the copy paper is in the feeding assembly, and check the image. Is the copy image normal? YES: The cause is after the fixing system. Check the fixing assembly upper/lower roller for dirt.</p>
Development Drum cleaner unit	<p>6) Is the surface of the developing cylinder coated with an even layer of toner? NO: [1] Check the edge of the blade of the developing assembly. [2] Check to make sure that the front fixing plate of the developing magnet is secured in place. YES: [1] Remove the drum cleaning blade, and check the edge. [2] Check the drum cleaner unit.</p>

3.3.9 The output has black lines (vertical, fine)

Scanner (dirt)	<p>1) Does the problem occur only in copy images? YES: The cause is between scanner and CCD. Perform the following:</p> <ul style="list-style-type: none"> [1] Check the standard white plate and the mirrors for dirt. [2] Execute the following in service mode: COPIER>FUNCTION>CCD>CCD-ADJ.
Fixing system	<p>2) Using the door switch actuator, make a copy with the front cover open. Turn off the power switch when the copy paper is in the feeding assembly, and check the image. Is the copy image normal? YES: The cause is after the fixing system. Perform the following:</p> <ul style="list-style-type: none"> [1] Check the fixing upper roller for scratches and black lines. [2] Check the web for dirt. [3] Check the thermistor and the separation claw for dirt. Check the reciprocating movement.
Primary charging assembly (dirt)	<p>3) Clean the primary charging assembly. Is the problem cord? YES: End.</p>
Photosensitive drum cleaner assembly	<p>4) Is foreign matter (e.g., paper) trapped by the cleaning blade of the cleaner unit? YES: Remove the foreign matter, and clean the cleaning blade and the outside of the cleaner unit.</p> <p>5) Is there a scratch on the edge of the cleaner blade? (Put a finger on the edge of the cleaning blade, and feel for a scratch.) YES: Turn over the edge. If both edges have a scratch, replace the cleaning blade.</p>
Photosensitive drum, Developing assembly	<p>6) Is there a scratch or black line in the peripheral direction of the surface of the photosensitive drum? YES: Replace the photosensitive drum. If a scratch is found, be sure to find out its cause. NO: Check the developing system.</p>

3.3.10 The output has white spots (vertical)

3.3.11 The output has white lines (vertical)

Copy paper	<p>1) Try paper fresh out of package. Is the problem corrected? YES: The copy paper is most. Advise the user on the place and method of storage.</p>
Dust-proofing glass	<p>2) Clean the dust-proofing glass. Is the problem corrected? YES: End.</p>
Scanner (dirt)	<p>3) Does the problem occur only in copy images? YES: The cause is between scanner and CCD. Perform the following: [1] Check the standard white plate for dirt. [2] Execute the following in service mode: COPIER>FUNCTION>CCD>CCD-ADJ.</p>
Photosensitive drum	<p>4) Is there a scratch on the surface of the photosensitive drum in peripheral direction corresponding to the problem in the images? YES: Find out the cause of the problem, and replace the photosensitive drum.</p>
Developing assembly	<p>5) Is the surface of the developing cylinder coated with an even layer of toner? NO: [1] Check if paper lint is trapped on the edge of the blade of the developing assembly. [2] Check to make sure that the connector at the front of the developing assembly is securely connected with the machine.</p>
Fixing assembly	<p>6) Using the door switch actuator, generate a test print (PG-TYPE6, solid black) with the front cover open. Turn off the switch immediately before the copy paper enters the fixing assembly, and check the image. Is the image normal? YES: The cause is after the fixing system. Perform the following: [1] Check the fixing upper roller for offset.</p>

Transfer/separation charging assembly, Pre-transfer charging assembly

7) Clean the pre-transfer charging assembly and the transfer/separation charging assembly. Is the problem corrected?

YES: End.

NO: Perform the following:

[1] Vary the setting of the following in service mode:
COPIER>OPTION>TRNSG-SW.

[2] Vary the setting for the following in service mode:
COPIER>OPTION>BODY>FUZZY.

Charging wire cleaner

8) Is the charging wire cleaning pad stopped midway?

YES: Execute wire pad cleaning in user mode ('adjust/clean').

3.3.12 The output has white spots (horizontal)

Developing assembly

1) Does the problem occur at intervals of about 79 mm?

- YES: [1] Clean the developing rolls.
 [2] Dry wipe the surface of the developing cylinder.
 [3] If the site of installation is at a high elevation, electrical leakage is a possibility between the developing cylinder and the drum. Try switching DIPSW from UP to DOWN on the high-voltage PCB (rear of the machine). This, however, lowers density.
 [4] If there is a scratch on the surface of the developing cylinder, replace the developing cylinder.

Drum

2) Does the problem occur at intervals of about 340 mm?

- YES: [1] Clean the drum (especially, where the developing rolls are in contact on both ends).
 [2] If there is a scratch on the surface of the drum, replace the drum.

Copy paper

3) Try paper fresh out of package. Is the problem corrected?

- YES: The copy paper is moist. Advise the user on the place of storage and the method of storage.

Scanner rail, Scanner cable

4) Does the problem occur only in copy images?

- YES: [1] Check the scanner cable for foreign matter.
 [2] Adjust the scanner cable for tension.

Charging wire (dirt), Photosensitive drum

5) Clean the charging wire. Is the problem corrected?

- YES: End.

6) Is there a scratch on the surface of the photosensitive drum?

- NO: Clean the charging assemblies.
 YES: Replace the photosensitive drum.

3.3.13 The back of the output is soiled

Transfer guide	<p>1) It the transfer guide soiled with toner? YES: [1] Clean the transfer guide. [2] Check the transfer guide bias. [3] Check the developing assembly for leakage of toner.</p>
Drum Cleaner	<p>2) Is the paper feeding assembly soiled with toner? YES: [1] Clean the feeding assembly. [2] Check the drum cleaning assembly for leakage of toner.</p>
Fixing assembly	<p>3) Is the fixing lower roller soiled? YES: [1] Clean the fixing lower roller. [2] Clean the inlet guide of the fixing assembly. [3] Check the fixing upper roller and the web for dirt. NO: Perform the following [1] Check the registration roller for dirt. [2] Check the delivery roller and the separation claw for dirt.</p>

3.3.14 The output has a fixing fault

Copy paper	<p>1) Is the paper of a type that adversely affect fixing (e.g., thick paper)? YES: Select thick paper in user mode (common settings>paper type). Advise the user to select a cassette for thick paper.</p> <p>2) Is the paper of a recommended type? NO: Try recommended paper. If the results are good, advise the user to use recommended paper.</p>
Fixing assembly	<p>3) Does the problem occur in vertical direction? YES: Check the fixing assembly for scratches and dirt. NO: Check the nip of the fixing roller.</p>

3.3.15 The output has a displaced leading edge (considerably large margin)

3.3.16 The output has a displaced leading edge (large margin)

3.3.17 The output has a displaced leading edge (no margin)

Original placement

1) **Is the original placed correctly?**

NO: Place the original correctly.

2) **Make copies using the following sources of paper; do they show different results of displacement?**

[1] left/right front deck

[2] cassette

[3] side paper deck

[4] duplex feeding assembly

YES: Check the source of paper with displacement of the following:

[1] life of the rollers

[2] paper lint on the rollers

[3] dirt in the power path

Registration clutch, Registration roller

3) **Make adjustments in the following service mode:**

COPIER>ADJUST>FEED-ADJ>REGIST. Is the problem corrected?

NO: [1] Check the registration roller for deformation and wear.

[2] Check the registration roller drive system.

YES: End.

3.3.18 The output is blurred

Scanner drive cable

1) Does the cable run wound around the cable pulley overlap when the scanner is moving? Or, is the cable too loose or too taut?

YES: [1] String the cable once again.

[2] If the cable is twisted or frayed, replace it.

Scanner rail

2) Move the No. 1 mirror base by hand. Does it move smoothly?

NO: Clean the surface of the scanner rail with alcohol. Thereafter, apply a small amount of silicone oil (S-20).

Photosensitive drum

3) Does the problem occur at intervals of about 340 mm?

YES: [1] Check the drum gear.

[2] Check the drum ends (where the developing rolls are in contact) for scratches and bumps.

Drum drive gear

4) Does the problem occur at intervals of about 4 mm?

YES: Check the drum drive gear.

Developing gear

5) Does the problem occur at intervals of about 2 mm?

YES: Check the developing assembly.

Drum drive system

6) Does the problem occur at intervals of about 10 mm?

YES: [1] Check the cleaner assembly.

[2] Check the drum drive system.

3.3.19 The output has horizontal fogging

-----	<p>1) Does the problem occur at the same location on copies made in Direct? YES: Go to step 3.</p>
Scanning lamp, Lamp regulator	<p>2) Does the scanning lamp flicker when the scanner is moving forward? YES: Check the scanning lamp and the lamp regulator.</p>
Scanner (wobbling), Feeding system (wobbling)	<p>3) Make a reduced copy, and compare it against a Direct copy. Are the locations of the problem different? NO: Check the scanner system. YES: Check the feeding system.</p> <p>4) Does the problem occur at intervals of about 79 mm? YES: If the dirt is in the form of dots, dry wipe the surface of the developing cylinder. If it is spread, go to 1.1.3 (checks on printer side 2/2; F06-101-03).</p>

3.3.20 The output has poor sharpness

Copyboard glass	<p>1) Is there adhesion of oil or the like on the copyboard glass? YES: Clean the copyboard glass.</p>
Mirror (position)	<p>2) Is the horizontal reproduction ratio of Direct copies as indicated? NO: Adjust the distance between NO. 1 mirror and NO. 2 mirror.</p>
Scanner (Dirt)	<p>3) Clean the scanning lamp, reflecting plate, mirrors, lens, and dust-proofing glass. Is the problem corrected? YES: End.</p>
Photosensitive Drum, Lens drive assembly	<p>4) Try replacing the photosensitive drum. Is the problem corrected? YES: End.</p>

3.3.21 The output is solid blank

Developing assembly (locking mechanism)	<p>1) Is the developing assembly locked in place to the photosensitive drum during copying operation? NO: Check the locking mechanism for the developing assembly.</p>
Developing assembly drive assembly	<p>2) Is the developing assembly rotating during copying operation? NO: Check the drive system of the developing assembly.</p>
Transfer charging assembly	<p>3) Is the transfer charging assembly fully fitted all the way to the rear? NO: Fit the transfer charging assembly fully to the rear.</p> <p>4) Do electrical leakage occur in the transfer charging assembly? YES: Check the transfer charging assembly.</p>
CCD unit, Relay PCB	<p>5) Is the voltage supplied to the CCD unit as rated? NO: [1] Check the relay PCB. [2] Check the power path between the CCD unit and the relay PCB; if normal, replace the CCD unit.</p>
Laser unit reader controller PCB, Drum unit	<p>6) Is the laser output normal? NO: [1] Replace the laser unit. [2] Replace the image processor PCB.</p> <p>7) Are the connector J1452 on the left side of the controller box and the connector J1302 on the laser drive PCB firmly connected? NO: Connect them firmly (so that they are locked in place). YES: Replace the drum unit.</p>
Developing bias connector	<p>8) Is the developing bias connector (machine rear) connected? NO: Connect it.</p>

3.3.22 The output is solid black

Scanning lamp	<p>1) Does the scanning lamp go ON? NO: See "The scanning lamp fails to go ON."</p>
Pre-exposure lamp	<p>2) Is the connector of the pre-exposure lamp connected? NO: Connect it.</p>
Primary charging assembly	<p>3) Make the following selections in service mode: COPIER>DISPLAY>DPOT. Is the setting of <VDM> between 390 and 460? NO: Check the primary charging assembly.</p>
-----	<p>4) Is the connection among the following normal? [1] reader controller PCB [2] CCD unit [3] DC controller PCB [4] relay PCB NO: Connect them correctly.</p>
Reader controller PCB, CCD unit	<p>5) Does the problem occur only in copy images? NO: [1] Replace the reader controller PCB. [2] Replace the DC controller PCB. YES: Replace the CCD unit.</p>

4 Troubleshooting Malfunctions

4.1 Troubleshooting by Malfunction



If you are removing or mounting any of the sensors, be sure to pay attention to the orientation/position of the spring used to keep the detecting lever in place.

4.1.1 E000

Thermistor

- 1) **Reset E000, and turn off and then on the power switch. Make the following selections in service mode: COPIER>DISPLAY>ANALOG. Do readings of both <FIX-C> and <FIX-E> indicate an increase in temperature?**
 YES: The cause is in the thermistor. Check the following:
 - thermistor for how it is mounted
 - thermistor for dirt on its surface
 - connection

DC controller PCB

- 2) **Turn off the power switch, and let the fixing upper roller cool sufficiently. Then, turn on the power switch. Reset E000, and turn off and then on the power switch. Make the following selections in service mode: COPIER>I/O>DC-CON. Are bit 0 and bit 1 of IO-P012 '0'?**
 YES: Replace the DC controller PCB.

Heater (open circuit), AC driver (triac; faulty)

- 3) **Is the electrical continuity of each heater normal?**
 NO: Replace the heater.
 YES: Check the wiring; if normal, replace the AC driver PCB.

4.1.2 E001

Triac (inside AC driver; short circuit)

- 1) **Keeping the power switch OFF, let the fixing upper roller cool sufficiently. In the meantime, check each thermistor for dirt on its surface, mounting, and connection.**

Turn on the power switch, and reset E001 by making the following selections in service mode, and turn off and then on the power switch: COPIER>FUNCTION>CLEAR>ERR.

Make the following selections in service mode:

COPIER>DISPLAY>ANALOG. Are the readings of both <FIX-C> and <FIX-E> 198°C or higher?

YES: Replace the AC driver PCB.

Thermistor (TH1/TH2; faulty), DC controller PCB

- 2) **Try replacing the thermistor. Is the problem corrected?**

YES: End.

NO: Replace the DC controller PCB.

4.1.3 E002

4.1.4 E003

-----	<p>1) Turn on the power switch, and reset E002 and E003 by making the following selections in service mode: COPIER>FUNCTION>CLEAR>ERR. Then, turn off and then on the power switch. Is any of the following true?</p> <ul style="list-style-type: none"> • The fixing heater fails to operate. • E002 or E003 is indicated. <p>YES: Go to each relevant section.</p>
-----	<p>2) Is the contact of the connector J505 on the DC controller PCB and the connectors inside the fixing assembly good? Also, is the wiring from the thermistor to the DC controller PCB good?</p> <p>NO: Make corrections.</p>
Main thermistor (TH1; mounting)	<p>3) Is the thermistor in even contact with the fixing upper roller?</p> <p>NO: Mount it correctly.</p>
Main thermistor (TH1; dirt)	<p>4) Clean the contact face of the thermistor. Is the problem corrected?</p> <p>YES: End.</p>
Main thermistor (TH1; faulty)	<p>5) Try replacing the thermistor. Is the problem corrected?</p>
DC controller PCB	<p>6) Try replacing the heater. Is the problem corrected?</p> <p>YES: End.</p> <p>NO: Replace the DC controller PCB.</p>

4.1.5 E004

AC driver pcb, DC controller PCB	<p>1) Try replacing the AC driver PCB. Is the problem corrected?</p> <p>YES: End.</p> <p>NO: Replace the DC controller PCB.</p>
----------------------------------	---

4.1.6 E005

Web	<p>1) Is the web of the fixing assembly taken up? YES: Replace it with a new web.</p>
Web detecting lever	<p>2) Is the position of the web detecting lever correct? NO: Correct the position of the lever.</p>
DC controller PCB, Sensor	<p>3) Is the web absent sensor (PS7) normal? (See instructions on how to check photointerrupters.) YES: Replace the DC controller PCB. NO: Replace the sensor.</p>

4.1.7 E010

-----	<p>1) Are the connectors J611 and J612 of the main motor connected? NO: Connect the connectors.</p>
-----	<p>2) Is the connector J1720 of the relay PCB connected? NO: Connect the connector.</p>
Relay PCB	<p>3) Close all doors. Is the voltage between connectors J1720-1 and -2 on the relay PCB about 38 V when the power switch is tuned on? NO: Replace the relay PCB.</p>
DC controller PCB, Main motor (M1)	<p>4) Does the voltage between J514-B5 (+) and J514-B3 (-) on the DC controller PCB change from 0 to about 5 V when the Start key is pressed? NO: Replace the DC controller PCB. YES: Replace the main motor.</p>

4.1.8 E012

Relay PCB, Drum motor (M0)

- 1) **Turn on the power switch, and measure the voltage between connectors J1721-9 and -10 on the relay PCB when all doors are closed. Is it 38 V?**

NO: If the connection of the cable up to the relay PCB is normal, replace the relay PCB.

DC controller PCB

- 2) **Does the voltage between J512-B10 (+) and J512-B8 (-) on the DC controller PCB change from 0 to 5 V when the Start key is pressed?**

NO: If the connection of the cable up to the DC controller PCB is normal, replace the DC controller PCB.

Connector

- 3) **Are the connectors J601 and J602 of the drum motor connected firmly?**

NO: Connect them firmly.

YES: Replace the drum motor.

4.1.9 E013

Waste toner feedscrew (locked)

- 1) **Is the waste tone feedscrew drive gear pushing the waste toner feedscrew lock detecting switch (MSW2)?**

NO: The feedscrew inside the waste toner pipe is likely to be stuck. Remove the waste toner pipe, and try turning the screw by hand. If it turns easily, mount it back and see what happens. If the screw cannot be turned by hand, replace the waste toner pipe, and remove the cause.

MSW2, DC controller PCB

- 2) **Make the following selections in service mode: COPIER>I/O>DC-CON. Is bit 6 of P003 '0', indicating clogging with toner?**

YES: Replace the MSW2.

NO: Replace the DC controller PCB.

4.1.10 E014

-----	<p>1) Are the connectors J651 and J652 of the fixing motor connected? NO: Connect the connectors.</p>
Relay PCB	<p>2) Is 38 V present between J651-1 and -2 of the fixing motor when the power switch is turned on with all doors closed? NO: Replace the relay PCB.</p>
DC controller PCB, Fixing motor (M3)	<p>3) Does the voltage between connectors J508-A18 (+) and J508-A16 (-) on the DC controller PCB change from 0 to about 5 V when the Start key is pressed? NO: Replace the DC controller PCB. YES: Replace the fixing motor.</p>

4.1.11 E015

-----	<p>1) Are the connectors J621 and J622 of the pickup motor connected? NO: Connect the connectors.</p>
Relay PCB	<p>2) Is 38 V present between J1721-11 and -11 of the relay PCB when all doors are closed? NO: Replace the relay PCB.</p>
DC controller PCB, Pickup motor (M2)	<p>3) Does the voltage between J513-A3 (+) and J513-A1 (-) on the DC controller PCB change from 0 to about 5 V when the Start key is pressed? NO: Replace the DC controller PCB. YES: Replace the pickup motor.</p>

4.1.12 E019

Waste toner case full

1) Is the waste toner case full of toner?

YES: Dispose of the toner inside the waste toner case.

Waste toner case base

2) Is the movement of the waste toner case smooth?

NO: Correct it.

Connector

3) Is the connector J514 on the DC controller PCB firmly connected?

NO: Connect the connector firmly.

Waste toner case full sensor, DC controller PCB

4) Try replacing the waste toner case full sensor (PS19). Is the problem corrected?

YES: If the connection of the cable up to the DC controller PCB is normal, replace the waste toner case full sensor (PS19).

NO: Replace the DC controller PCB.

4.1.13 E020

Toner feedscrew, Toner sensor (TS3)

1) Remove the developing assembly, and detach the top cover of the assembly. Is there toner inside the assembly?

YES: Check the rotation of the toner feedscrew inside the developing assembly; if normal, replace the toner sensor (TS3).

2) Make the following selections in service mode:**COPIER>FUNCTION>PART-CHK. Check the operation of the hopper drive clutch (CL1) using <CL>. Does the clutch operate?**

NO: Check the connection; if normal, replace the clutch.

Hopper drive clutch (CL1)

3) Check the operation of the hopper motor (M18) using <MTR>. Does the motor operate?

NO: Check the connection; if normal, replace the motor.

YES: Check the following:

- magnet roller inside the hopper for rotation
- clogging of toner between and inside the hopper and the developing assembly

4.1.14 E025

Connector	<p>1) Is the connector J512 on the DC controller PCB firmly connected? NO: Connect it firmly</p>
Drive system, Toner feed motor (M6; inside cartridge)	<p>2) Does the drive system for toner feeding inside the cartridge operate smoothly? NO: Correct it. YES: Replace the toner feed motor inside the cartridge.</p>

4.1.15 E032

Connector	<p>1) Is the copy data controller or the NE controller connected firmly, i.e., connectors J525 and J526 on the DC controller PCB? NO: Connect it firmly.</p>
DC controller PCB, Copy data controller or NE controller	<p>2) Try replacing the copy data controller or the NE controller. Is the problem corrected? NO: Replace the DC controller PCB. YES: Make corrections.</p>

4.1.16 E043

Side deck drive PCB	<p>1) Is there electrical continuity between the following connectors on the side deck drive PCB?</p> <table border="1" style="margin-left: 40px;"> <thead> <tr> <th style="width: 15%;">Signal</th> <th style="width: 70%;">Connectors</th> </tr> </thead> <tbody> <tr> <td>38VU</td> <td>J106-1 \longleftrightarrow J101-1</td> </tr> <tr> <td>0VU</td> <td>J106-2 \longleftrightarrow J101-2</td> </tr> </tbody> </table> <p>NO: Replace the side deck driver PCB.</p>	Signal	Connectors	38VU	J106-1 \longleftrightarrow J101-1	0VU	J106-2 \longleftrightarrow J101-2
Signal	Connectors						
38VU	J106-1 \longleftrightarrow J101-1						
0VU	J106-2 \longleftrightarrow J101-2						
Deck main motor (M101), DC controller PCB	<p>2) Try replacing the deck main motor (M101) of the side paper deck. Is the problem corrected? YES: End. NO: Check the harness from the DC controller PCB to the motor; if normal, replace the DC controller PCB.</p>						

4.1.17 E051

Horizontal registration home position sensor (PS18)

- 1) Is the horizontal registration home position sensor (PS18) normal?**
NO: Replace PS18.

Horizontal registration motor M15)

- 2) Disconnect J3603 of the stackless feed driver PCB. Is there electrical continuity between the following pins of the jacks on the motor side?**
J3603-B4 and -B5 and -B3
J3603-B2 and -B6 and -B1
NO: Replace the horizontal registration motor (M15).

Manual feed tray open/closed detecting switch (MSW5)

- 3) Is the mounting of the manual feed tray open/closed detecting switch (MSW5) normal?**
NO: Correct the mounting.

Stackless feed driver PCB, DC controller PCB

- 4) Try replacing the stackless drive PCB. Is the problem corrected?**
YES: end.
NO: Replace the DC controller PCB.

4.1.18 E065

Primary charging assembly (dirt)	<p>1) Is the primary charging assembly soiled with paper lint or the like? YES: Clean the primary charging assembly.</p>
Mounting	<p>2) Is the primary charging assembly mounted firmly? NO: Mount it firmly.</p>
Contact	<p>3) Is the contact of the primary charging assembly clean? NO: Clean or correct it.</p>
Connection	<p>4) Is the connection of the following on the HV-DC PCB firm? (See F06-401-01.)</p> <ul style="list-style-type: none"> • T601 • J723 • J730 <p>NO: Connect them firmly.</p>
Wiring, HV-DC PCB	<p>5) Is the wiring from the HV-DC PCB to the primary charging assembly normal? NO: Correct the wiring. YES: Replace the HV-DC PCB.</p>

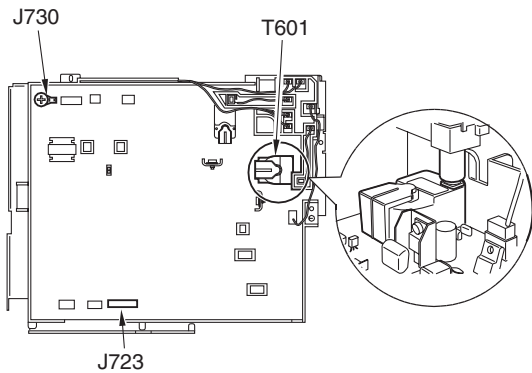

F06-401-01

4.1.19 E067

Mounting	<p>1) Are the primary charging assembly, pre-transfer charging assembly, and transfer/separation charging assembly mounted firmly? NO: Mount them firmly.</p>
Connection	<p>2) Are the following connectors on the HV-DC PCB and the screws connected and tightened firmly? (See F05-401-02.)</p> <ul style="list-style-type: none"> • J721 • J723 • J730 <p>NO: Connect or tighten firmly.</p>
Wiring	<p>3) Is the wiring from the HV-DC PCB to each charging assembly and the wiring from the HV-AC PCB to each charging assembly normal? NO: Corrected the wiring.</p>
HV-AC PCB, HV-DC PCB	
	<p>4) Disconnect the connector J722 of the HV-DC PCB, and execute copying. Is E067 indicated? NO: Replace the HV-AC PCB, and connect the connector J722. YES: Replace the HV-DC PCB, and connect the connector J722.</p>

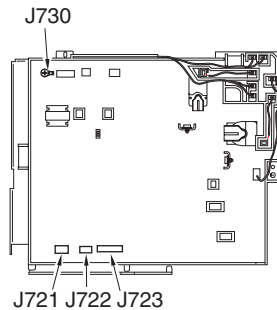

F06-401-02

4.1.20 E068

Mounting	<p>1) Is the transfer/separation charging assembly mounted firmly? NO: Mount it firmly.</p>										
Connection	<p>2) Are the following connectors on the HV-DC PCB and HV-AC PCB and the screws connected and tightened firmly? (See F06-401-03.)</p> <table border="1" style="margin-left: 40px;"> <thead> <tr> <th style="width: 50%;">HV-DC PCB</th> <th style="width: 50%;">HV-AC PCB</th> </tr> </thead> <tbody> <tr> <td>• J722</td> <td>• J741</td> </tr> <tr> <td>• J722</td> <td>• J742</td> </tr> <tr> <td>• J722</td> <td></td> </tr> <tr> <td>• J734</td> <td></td> </tr> </tbody> </table> <p>NO: Connect and tighten them firmly.</p>	HV-DC PCB	HV-AC PCB	• J722	• J741	• J722	• J742	• J722		• J734	
HV-DC PCB	HV-AC PCB										
• J722	• J741										
• J722	• J742										
• J722											
• J734											
Separation charging assembly	<p>3) Disconnect the connector T1-S from the transformer assembly of the HV-AC PCB, and execute copying. Is E068 indicated? (See F06-401-04.) NO: Clean the separation charging assembly. If E068 still is indicated when executing copying, replace the separation charging assembly.</p>										

Pre-transfer charging assembly, HV-DC PCB

- 4) **Disconnect the connector T1-Q from the transformer assembly of the HV-AC PCB, and execute copying. Is E068 indicated? (See F06-401-04.)**

NO: Clean the pre-transfer charging assembly. If E068 is still indicated when copying is executed, replace the pre-transfer charging assembly.

YES: Replace the HV-AC PCB.

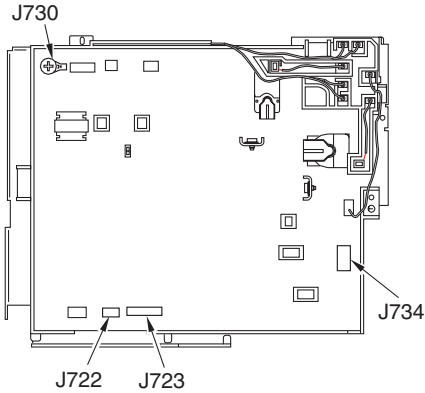

F06-401-03

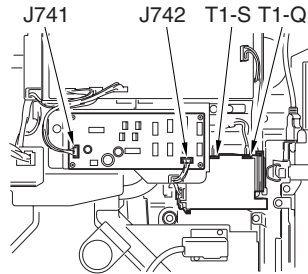

F06-401-04

4.1.21 E069

Mounting	<p>1) Is the transfer/separation charging assembly mounted firmly? NO: Mount it firmly.</p>
Connection	<p>2) Are the following connectors on the HV-DC PCB and the screws connected and tightened firmly?</p> <ul style="list-style-type: none"> • T701 • J723 • J730 <p>NO: Connect and tighten them firmly.</p>
Wiring	<p>3) Is the wiring from the HV-DC PCB to the transfer/separation charging assembly (transfer charging assembly side) normal? NO: Correct the wiring.</p>
<p>HV-DC PCB, Transfer/separation charging assembly</p> <p>4) Try replacing the transfer/separation charging assembly. NO: Replace the transfer/separation charging assembly. YES: End.</p>	

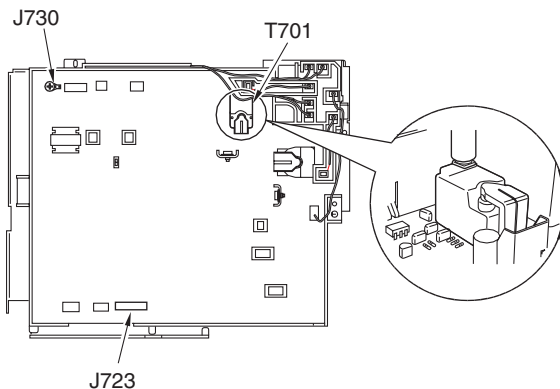

F06-401-05

4.1.22 E100

BD PCB	<p>1) Make the following selections in service mode: COPIER>DISPLAY>DPOT. Is the reading of <VLIM> between 50 and 90?</p> <p>YES: Check the connection of the BD PCB, laser driver PCB, and DC controller PCB; and check the position of the BD PCB. If normal, replace the BD PCB.</p>
--------	--

Laser output, DC controller PCB

- 2) **Is the reading of <VDM> between 360 and 420?**
- YES: Check the following:
- laser output
 - laser path for foreign matter
- NO: Replace the DC controller PCB

4.1.23 E110

Connector	<p>1) Is the connector J762 on the laser scanner motor driver PCB connected firmly?</p> <p>NO: Connect it firmly.</p>
-----------	--

Connector	<p>2) Is the connector J503 on the DC controller PCB connected firmly?</p> <p>NO: Connect it firmly.</p>
-----------	---

Laser scanner unit, DC controller PCB

- 3) **Try replacing the laser scanner unit. Is the problem corrected?**
- NO: End.
- YES: Replace the DC controller PCB.

4.1.24 E111

Foreign matter	<p>1) It here foreign matter that prevents the rotation of the laser scanner motor cooling fan? YES: Remove the foreign matter.</p>
Connector	<p>2) Is the connector J503 on the DC controller PCB connected firmly? NO: Connect it firmly</p>
Laser scanner fan (FM14), DC controller PCB	<p>3) Try replacing the laser scanner motor fan (FM14). Is the problem corrected? YES: End. NO: Replace the DC controller PCB.</p>

4.1.25 E121-0001

Foreign matter	<p>1) Is there foreign matter that prevents the rotation of the scanner cooling fan? YES: Remove the foreign matter.</p>
Connector	<p>2) Is the connector J503 on the reader controller PCB connected firmly? NO: Connector it firmly.</p>
Scanner cooling fan (FM3), Reader controller PCB	<p>3) Try replacing the scanner cooling fan (FM3). Is the problem corrected? NO: End. YES: Replace the reader controller PCB.</p>

4.1.26 E121-0002

Foreign matter	<p>1) Is there foreign matter that prevents the rotation of the laser driver cooling fan? YES: Remove the foreign matter.</p>
Connector	<p>2) Is the connector J503 on the DC controller PCB connected firmly? NO: Connect it firmly.</p>
Laser driver cooling fan (FM5), DC controller PCB	<p>3) Try replacing the laser drive cooling fan (FM5). Is the problem corrected? NO: End. YES: Replace the DC controller PCB.</p>

4.1.27 E202 (The keys in the control panel are locked.)

-----	<p>1) Is the scanner in home position when E202 is indicated? NO: See "The scanner fails to move forward."</p>
Connector	<p>2) Is the connector J1702 on the relay PCB connected firmly? NO: Connect it firmly.</p>
Scanner home position sensor (PS1), Reader controller PCB	<p>3) Is the scanner home position sensor (PS1) normal? (See the instructions on how to check photointerrupters.) YES: Check the wiring from the reader controller PCB to PS1; if normal, replace PS1. NO: Replace the reader controller PCB.</p>

4.1.28 E204 (The keys in the control panel are locked.)

-----	<p>1) Does the scanner move forward when the Start key is pressed? NO: See “The scanner fails to move forward.”</p>
Scanner image leading edge sensor (PS3), Reader controller PCB	<p>2) Is the scanner image leading edge sensor (PS3) normal? (See the instructions on how to check photointerrupters.) NO: Check the wiring from the reader controller PCB to PS3; if normal, replace PS3. YES: Replace the reader controller PCB.</p>

4.1.29 E211
 4.1.30 E215

Connector	<p>1) Are the connectors J852 and J853 on the light control PCB firmly connected? NO: Connector them firmly.</p>
Fluorescent lamp heater	<p>2) Try replacing the fluorescent lamp heater. Is the problem corrected? YES: End.</p>
Light control PCB, Reader controller PCB	<p>3) Try replacing the light control PCB. Is the problem corrected? YES: End. NO: Replace the reader controller PCB.</p>

4.1.31 E218

Mounting	<p>1) Is the fluorescent lamp mounted firmly? NO: Mount it firmly.</p>
Connector	<p>2) Are the connectors J1002 and J1003 on the inverter PCB firmly connected? NO: Connect them firmly.</p>
Fluorescent lamp, Reader controller PCB	<p>3) Try replacing the fluorescent lamp. YES: End. NO: Replace the reader controller PCB. 4) Is J1702 on the relay PCB connected correctly? NO: Connect it correctly.</p>

4.1.32 E219

4.1.33 E220

4.1.34 E222

Connector	<p>1) Are the connectors J852 and J853 on the light control PCB firmly connected? NO: Connect them firmly.</p>
Fluorescent lamp heater	<p>2) Try replacing the fluorescent heater. Is the problem corrected? YES: End.</p>
Light control PCB, Reader controller PCB	<p>3) Try replacing the light control PCB. YES: End. NO: Replace the rear controller PCB.</p>

4.1.35 E226

Foreign matter	<p>1) Is there foreign matter that prevents the rotation of the scanner cooling fan? YES: Remove the foreign matter.</p>
Connector	<p>2) It the connector J503 on the reader controller PCB connected firmly? NO: Connect them firmly.</p>
Scanner cooling fan (FM3), Reader controller PCB	<p>1) Try replacing the scanner cooling fan (FM3). Is the problem corrected? NO: End. YES: Replace the reader controller PCB.</p>

4.1.36 E240

DC controller PCB	<p>1) Turn off and then on the power switch. Is the problem corrected? YES: End. NO: Replace the DC controller PCB.</p>
-------------------	--

4.1.37 E241

Mounting	<p>1) Is the original orientation detection PCB mounted firmly? NO: Mount it firmly.</p>
Reader controller PCB	<p>2) Try replacing the original orientation PCB. Is the problem corrected? YES: End. NO: Replace the rear controller PCB.</p>

4.1.38 E243

Controller PCB	<p>1) Turn off and then on the power switch. YES: End. NO: Replace the controller PCB.</p>
Control panel PCB	<p>2) Try replacing the control panel PCB. Is the problem corrected? YES: End.</p>

4.1.39 E251

Foreign matter	<p>1) Is there foreign matter that prevents the rotation of the inverter cooling fan? YES: Remove the foreign matter.</p>
Connector	<p>2) Is the connector J1110 on the reader controller PCB connected firmly? NO: Connect it firmly.</p>
Inverter cooling fan (FM9), Reader controller PCB	<p>3) Try replacing the inverter cooling fan (FM9). Is the problem corrected? NO: End. YES: Replace the reader controller PCB.</p>

4.1.40 E302

Connector

- 1) Are the connectors J1502 and J1503 on the CCD PCB and the J1107 and J1108 on the reader controller PCB connected firmly?**
 NO: Connector them firmly.

CCD PCB, Reader controller PCB

- 2) Try replacing the CCD PCB. Is the problem corrected?**
 YES: End.
 NO: Replace the reader controller PCB.

4.1.41 E315

Rear controller PCB

- 1) Try replacing the reader controller PCB. Is the problem corrected?**
 YES: End.

Main controller PCB

- 2) Try replacing the main controller PCB. Is the problem corrected?**
 YES: End.

4.1.42 E320

Connector

- 1) Are the connectors J1502 and J1503 on the CCD PCB and the J1107 and J1108 on the reader controller PCB connected firmly?**
 NO: Connector them firmly.

CCD PCB, Reader controller PCB

- 3) Try replacing the CCD PCB. Is the problem corrected?**
 YES: End.
 NO: Replace the reader controller PCB.

4.1.43 E400

Communication cable

- 1) **Is the connection of the communication cable between ADF and the machine normal?**

NO: Correct it.

ADF controller PCB

- 2) **Try replacing the ADF controller PCB. Is the problem corrected?**

YES: End.

4.1.44 E402

-
- 1) **Set the bits of the DIP switch (SW1) on the ADF controller PCB as follows:**

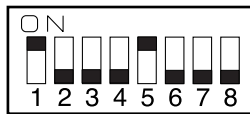

F06-401-06

Does the belt motor (M2) rotate when the push switch (SW2) is pressed? (To stop, press the push switch (SW2) once again.)

YES: Go to step 3.

Belt motor (M2)

- 2) **Disconnect the connector (J62) on the belt motor driver PCB. Set the meter range to X1, and connect the probes of the meter to the connectors on the cable side as follows. Is the resistance about 1.1Ω?**

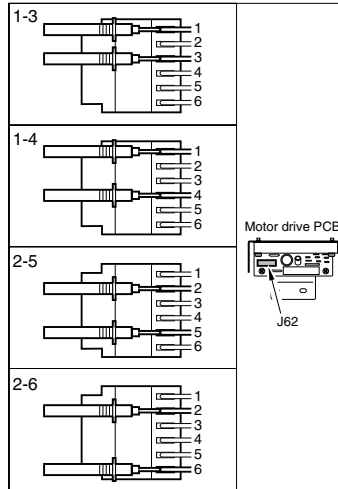

F06-401-07

NO: Replace the belt motor (M2).

Belt motor clock sensor (PI1)

- 3) **Set the meter range to 10 VDC. Does the voltage between the connectors J12-2 (+) and J12-1 (-) on the ADF controller PCB alternate between 0 and 5 V when the belt motor is turned by hand?**

NO: Replace the belt motor clock sensor (PI1).

Cable

- 4) **Is the cable between the belt motor driver PCB and the ADF controller PCB connected correctly?**

NO: Connect it correctly.

Belt motor drive PCB, ADF controller PCB

- 5) **Try replacing the belt motor drive PCB. Is the problem corrected?**

YES: Replace the belt motor driver PCB.

NO: Replace the ADF controller PCB.

4.1.45 E404

- 1) Set the bits of the DIP switch (SW1) on the ADF controller PCB as follows:

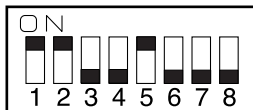

F06-401-08

Does the delivery motor (M5) rotate when the push switch (SW2) is pressed? (To stop, press the push switch (SW2) once again.)

YES: Go to step 3.

Delivery motor (M5)

- 2) Disconnect the connector J2 from the ADF controller PCB. Set the meter range to $\times 1\Omega$, and connect the meter probes to the connectors on the cable side. Is the resistance about 15Ω ?

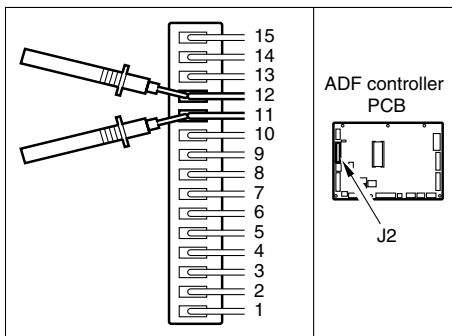

F06-401-09

NO: Replace the delivery motor (M5).
After replacement, be sure to perform "adjustment of the sensors and the delivery motor."

Delivery motor clock sensor (PI1), ad controller PCB

- 3) Set the meter range to 10 VDC. Does the voltage between the connectors J3-2 (+) and J3-1 (-) on the ADF controller PCB alternate between 0 and 5 V when the delivery motor is turned by hand?

NO: Replace the delivery motor clock sensor (PI1).

YES: Replace the ad controller PCB.

4.1.46 E405

- 1) **Set the bits of the DIP switch (SW1) on the ADF controller PCB as follows:**

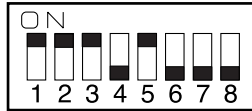

F06-401-10

Does the separation motor (M4) rotate when the push switch (SW2) is pressed? (To stop, press the push switch (SW2) once again.)

YES: Go to step 3.

Separation motor (M4)

- 2) **Disconnect the connector (J8) on the ADF controller PCB. Set the meter range to $\times 1\Omega$, and connect the meter probes to the connectors on the cable side. Is the resistance about 5.0Ω ?**

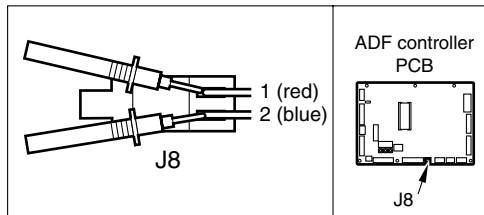

F06-401-11

NO: Replace the separation motor (M4).

Separation motor clock sensor (PI2), ADF controller PCB

- 3) **Set the meter range to 10 VDC. Does the voltage between the connectors J12-5 (+) and J12-4 (-) on the ADF controller PCB alternate between 0 and 5 V when the separation motor is turned by hand?**

NO: Replace the separation motor clock sensor (PI2).

YES: Replace the ADF controller PCB.

4.1.47 E410

- 1) Set the bits of the DIP switch (SW1) on the ADF controller PCB as follows:

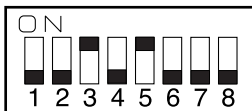

F06-401-12

Does the motor (M3) rotate when the push switch SW2 is pressed and then push switch SW3/SW4 is pressed? (To stop, press the push switch (SW2) once again.)

YES: Go to step 3.

Pickup motor (M3)

- 2) Disconnect the connector (J11) of the ADF controller PCB. Set the meter range to $\times 1\Omega$, and connect the meter probes to the connectors on the cable side. Is the resistance about 74Ω ?

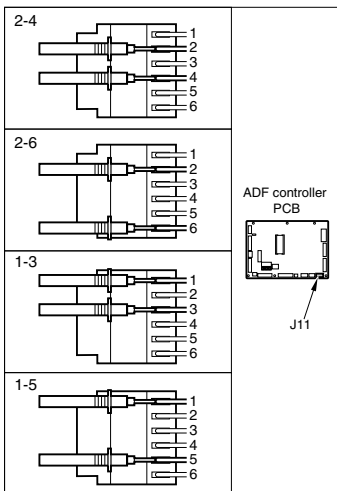

F06-401-13

NO: Replace the pickup motor (M3).

Pickup roller height sensor 1 (PI8)	<p>3) Set the meter range to 10 VDC. Does the voltage between the connectors J14-A8 (+) and J14-A7 (-) on the ADF controller PCB alternate between 0 and 5 V when the pickup roller unit (rear) is moved up and down by hand?</p> <p>NO: Replace the pickup roller height sensor 1 (PI8).</p>
Pickup roller height sensor 2 (PI9)	<p>4) Set the meter range to 10 VDC. Does the voltage between the connectors J14-A11 (+) and J14-A10 (-) on the ADF controller PCB alternate between 0 and 5 V when the pickup roller unit (front) is moved up and down by hand?</p> <p>NO: Replace the pickup roller height sensor 2 (PI9).</p>
Pickup roller home position sensor (PI7)	<p>5) Set the meter range to 10 VDC. Is there voltage of the connectors J14-A5 (+) and J14-A4 (-) on the ADF controller PCB about 5 V when the pickup roller is moved back to home position by hand?</p> <p>NO: Replace the pickup roller home position sensor (PI7).</p>
ADF controller PCB	<p>6) Try replacing the ADF controller PCB. Is the problem corrected?</p> <p>YES: Replace the ADF controller PCB.</p>

4.1.48 E422

Communication cable	<p>1) Is the connection of the communication cable between the ADF controller PCB and the machine normal?</p> <p>NO: Correct it.</p>
Connector	<p>2) Is there connection of the connector J1 on the ADF controller PCB normal?</p> <p>NO: Correct it.</p>
Cable, ADF controller PCB	<p>3) Is the cable from the connector J1 of the ADF controller PCB to the communication cable normal?</p> <p>NO: Correct the cable.</p> <p>YES: Replace the ADF controller PCB.</p>

4.1.49 E601

HDD Connector

1) **Are the connectors and the cables between the Hard disk drive and the main controller PCB firmly connected?**

NO: Correct them.

Wiring

2) **Are the connectors and the cables between the DC controller PCB and the main controller PCB firmly connected?**

NO: Correct them.

Hard disk

3) **Try replacing the hard disk. Is the problem corrected?**

YES: End.

DC controller PCB, Main controller PCB

4) **Try replacing the DC controller PCB. Is there problem corrected?**

YES: End.

NO: Replace the main controller PCB.

4.1.50 E602

System software (installation)

1) **Is the installation of the system software complete?**

NO: Install the system software.

Connector

2) **Are the connectors and the cables between the HDD and the main controller PCB correct?**

NO: Correct them.

HDD, Main controller PCB

3) **Using the Service Support Tool, format the HDD; then, install the system software once again. Is there problem corrected?**

YES: End.

NO: Make the following selections in service mode to repair the faulty sectors: FUNCTION>SYSTEM>HD-Check (0). Is the problem corrected?

4) **Try replacing the hard disk drive. Is the problem corrected?**

YES: End.

NO: Replace the main controller PCB.

4.1.51 E676

4.1.52 E677

Connector	1) Is the connection for the printer board (accessory) correct? NO: Correct it.
Connector	2) Is the connector between the riser PCB and the main controller PCB correct? NO: Correct it. YES: Correct it.
Riser PCB, Main controller PCB	3) Try replacing the riser PCB. Is the problem corrected? YES: End. NO: Replace the main controller PCB.
E677-5802	4) Machine types are not compatible between Boot ROM and System. (e.g., Boot ROM for the iR8500 Copy model is mounted on the system for the iR8500 PS/PCL model.) YES: Replace Boot ROM with an appropriate one.

4.1.53 E710-0001 (reader controller), E710-0002 (DC controller), E710-0003 (main controller)

4.1.54 E711-0001 (reader controller), E711-0002 (DC controller), E711-0003 (main controller)

Malfunition, DC controller PCB	1) Turn off and then on the power switch. Is the problem corrected? YES: End. NO: Replace the reader controller PCB. (0001) Replace the DC controller PCB. (0002) Replace the main controller PCB. (0003)
--------------------------------	--

4.1.55 E712

Malfunction	1) Turn off and then on the power switch. Is the problem corrected? YES: End.
Connector	2) Is the connector (J772) used to connect the and the copier connected firmly to the copier? NO: Replace the reader controller PCB.
ADF controller PCB, Reader controller PCB	3) Try replacing the ADF controller PCB. Is the problem corrected? YES: End. NO: Replace the reader controller PCB.

4.1.56 E713

Malfunction	1) Turn off and then on the power switch. Is the problem corrected? YES: End.
Connector	2) Is the connector (J152) used to connector the finisher and the copier connected firmly to the copier? NO: Replace the DC controller PCB.
Finisher controller PCB, DC controller PCB	3) Try replacing the finisher controller PCB. Is the problem corrected? YES: End. NO: Replace the DC controller PCB.

4.1.57 E717

Power supply	<p>1) Is the copy data controller or the NE controller correctly supplied with power? NO: Correct it. Note: You must clear the error in service mode: COPIER>FUNCTION>CLEAR>ERR.</p>
Wiring	<p>2) Is there cable between the copy data controller or the NE controller and the machine normal? NO: Correct it. Note: You must clear the error in service mode: COPIER>FUNCTION>CLEAR>ERR.</p>
Copy data controller or NE controller	<p>3) Try replacing the copy data controller or the NE controller. Is the problem corrected? YES: End.</p>

4.1.58 E732

Wiring	<p>1) Are the connectors and the cables for the main controller PCB and the reader controller PCB normal? NO: Correct them.</p>
Reader controller PCB	<p>2) Try replacing the reader controller PCB. Is the problem corrected? YES: End. NO: Replace the main controller PCB.</p>

4.1.59 E733

Wiring	<p>1) Are the connectors and cables between the main controller PCB and the DC controller PCB normal? NO: Correct them.</p>
DC controller PCB	<p>2) Try replacing the DC controller PCB. Is the problem corrected? YES: End. NO: Replace the main controller PCB.</p>

4.1.60 E737

SDRAM (mounting)

1) Is the SDRAM on the main controller mounted correctly?

NO: Mount it correctly.

SDRAM

2) Try replacing the SDRAM. Is the problem corrected?

YES: End.

NO: Replace the main controller PCB.

4.1.61 E740

Ethernet card (mounting)

1) Is the Ethernet card mounted correctly?

NO: Correct it.

Ethernet card

2) Try replacing the Ethernet card. Is the problem corrected?

NO: Replace the main controller PCB.

4.1.62 E741

Riser board (mounting)

1) Is the riser board mounted correctly?

NO: Correct it.

LIPS board (mounting)

2) Is the LIPS board mounted correctly?

NO: End.

YES: Replace the main controller PCB.

4.1.63 E744

Language module

1) **Was the language module installed during upgrading work?**

NO: Install it.

Version (system and boot ROM)

2) **Is the boot ROM designed for a different model?**

YES: Replace the boot ROM with a correct one.

E744-1000

3) **Machine models are not identical between Boot ROM and System. (e.g., Boot ROM for the iR5000 Copy model is mounted on the System for the iR8500 Copy model)**

YES: Replace Boot ROM with an appropriate one.

E744-2000

4) **HDD stored the system for another machine model is connected. (e.g., HDD for the iR8500 Copy model is changed the HDD for the iR105 Copy model)**

YES: Replace HDD with the one in which appropriate system is stored.

4.1.64 E800

Malfunction

1) **Turn off and then on the power switch. Is the problem corrected?**

YES: End.

J24

2) **Is the connector J505 on the DC controller PCB and then connector J1719 on the relay PCB connected securely?**

NO: Connect the connectors securely.

Relay PCB, DC controller PCB

3) **Is the voltage of the connector J505-B13 on the DC controller PCB about 0 V?**

YES: Check the wiring and electrical continuity from the DC controller PCB to the relay board PCB; if normal, replace the relay board PCB.

4.1.65 E804

Foreign matter	<p>1) Is there foreign matter that prevents the rotation of the power supply cooling fan (1/2)? YES: Remove the foreign matter.</p>
Connector	<p>2) Is the connector (J505) of the DC controller PCB connected firmly? NO: Connect it firmly.</p>
Power supply cooling fan 1/2 (FM11/12), DC controller PCB	<p>3) Try replacing the power supply fan (1/2). Is the problem corrected? NO: End. YES: Replace the DC controller PCB.</p>

4.1.66 E805

Foreign matter	<p>1) Is there foreign matter that prevents the rotation of the fixing assembly heat discharge fan? YES: Remove the foreign matter.</p>
Connector	<p>2) Is the connector (J503) on the controller PCB connected firmly? NO: Connect it firmly.</p>
Fixing heat discharge fan (FM2), DC controller PCB	<p>3) Try replacing the fixing the discharge fan (FM2). Is the problem corrected? NO: End. YES: Replace DC controller PCB.</p>

4.1.67 E820

Foreign matter	<p>1) Is there foreign matter that prevents the rotation of the drum fan? YES: Remove the foreign matter.</p>
Connector	<p>2) Is the connector (J512) on the DC controller PCB connected firmly? NO: Connect it correctly.</p>
Drum fan (FM8), DC controller PCB	<p>3) Try replacing the drum fan (FM8). Is the problem corrected? NO: End. YES: Replace the DC controller PCB.</p>

4.1.68 E823

Foreign matter	<p>1) Is there foreign matter that prevents the rotation of the pre-transfer charging assembly fan? YES: Remove the foreign matter.</p>
Connector	<p>2) Is the connector (J504) on the DC controller PCB firmly connected? NO: Connect it firmly.</p>
Pre-transfer charging assembly fan (FM10), DC controller PCB	<p>3) Try replacing the pre-transfer charging assembly (FM10). Is the problem corrected? NO: End. YES: Replace the DC controller PCB.</p>

4.1.69 E824

Foreign matter	<p>1) Is there foreign matter that prevents the rotation of the primary charging assembly fan? YES: Remove the foreign matter.</p>
Connector	<p>2) Is the connector (J503) on the DC controller PCB connected firmly? NO: Connect it firmly.</p>
Primary charging assembly fan (FM1), DC controller PCB	<p>3) Try replacing the primary charging fan (FM1). Is the problem corrected? NO: End. YES: Replace the DC controller PCB.</p>

4.1.70 E830

Foreign matter	<p>1) Is there foreign matter that prevents the rotation of the separation fan? YES: Remove the foreign matter.</p>
Connector	<p>2) Is the connector (J509) on the DC controller PCB connected firmly? NO: Connect it firmly.</p>
Separation fan (FM13), DC controller PCB	<p>3) Try replacing the separation fan (FM13). Is the problem corrected? NO: End. YES: Replace the DC controller PCB.</p>

4.1.71 AC power is absent

Power plug	<p>1) Is the work plug connected to the power outlet? NO: Connect the power plug.</p>
Source power	<p>2) Is the rated AC voltage present at the power outlet? NO: The problem is not of the copier's. Advise the user.</p>
Leakage breaker	<p>3) Remove the rear cover, and check to find out if the leakage breaker mounted to the power cord base has gone ON (at ○). YES: Remove the cause of activation, and shift the switch of the leakage breaker to the 'I' marking.</p>
Power cord, AC driver PCB	<p>4) Try replacing the power cord and the AC driver PCB. Is AC power supplied? YES: End. NO: Check the wiring for AC power, and check the connectors for poor contact.</p>
Connector	<p>5) Turn on the control panel power switch. Is the power supplied to the connector (J28) on the DC power supply PCB? NO: Check the connection between the main controller PCB (J1021) and the all-night power supply PCB (J785).</p>
All-night power supply PCB	<p>6) Turn on the control panel power switch. Is 3.3 V supplied to the connectors (J1021-1 and -2) on the main controller PCB? NO: Replace the all-night power supply PCB.</p>
Power switch (SW1), Wiring	<p>7) Connect the meter probes across both terminals of the power switch (SW1). Is the resistance 0Ω when the switch is ON, and ∞Ω when the switch is OFF? NO: Replace the power switch. YES: Check the wiring for AC power, and check the connector for contact.</p>

4.1.72 The DC power supply fails to operate. 1

Control pane power switch-related items

- 1) **Is the main power lamp ON?**
 YES: See “The DC power supply fails to operate. 2”

AC power supply

- 2) **Is the rated voltage present between J28-1 and J28-5 and between J28-2 and J28-7 on the DC power supply PCB?**
 NO: See “AC power is absent.”

Wiring

- 3) **Is the cable of the connector J1701-4 (overcurrent detection signal 1) on the relay PCB normal?**
 NO: Correct it.

Fuse (FU101)

- 4) **Is the fuse (FU101) on the DC power supply PCB blown?**
 YES: Remove the cause, and replace the fuse.

Wiring, DC load, DC power supply PCB

- 5) **Turn off the main power switch. When the main power switch is turned on in about 3 min, is the voltage between the following terminals of the relay PCB normal?**

Connector	Pin No.	Output voltage	Remarks
J1704	1	12V	+7%, -10%
	3	3.3V	±5%
J1705	1	+8V	±10%
	3	-8V	±10%
	5	15V	±10%
J1706	1	5V	±4%

However, the output voltages in the table are based on a tolerance in AC input of ±10%.

YES: Turn off the power switch, and disconnect the following connectors of the relay PCB:

- J1711
- J1712
- J1714
- J1716
- J1718

Connect one of the disconnected connectors, and turn on the power switch. Repeat this for all connectors to find the connector for which the protective circuit goes ON. Then, check the wiring and DC loads connected to the connector.

NO: Replace the DC power supply PCB.

4.1.73 Pickup fails

-----	<p>1) Slide in and out the cassette. Are the sounds of the lifter drop and the lifter motor turning heard? NO: See “The lifer fails to move up.”</p>
Drive gear	<p>2) Is the drive belt attached correctly? NO: Attach the drive belt correctly.</p>
Right upper cover, Right lower cover	<p>3) Are the right upper cover and the right lower cover fully closed? NO: Close the covers fully.</p>
Pressure spring	<p>4) Are the right upper cover and the right lower cover locking the vertical path rollers 1, 2, 3, and 4 in place? NO: Check the locking spring.</p>
Vertical path 1 clutch (CL8), Vertical path 2 clutch (CL9), Vertical path 3 clutch (CL13), Vertical path 4 clutch (CL15), Pre-registration roller clutch (CL5)	<p>5) Open the right upper cover and the right lower cover; then, put paper over the cover open/closed sensor assembly, and press the Start key. Does the vertical path rollers 1, 2, 3, and 4 and the pre-registration roller rotate? NO: Check the wiring; if normal, replace the clutch.</p>
Registration roller drive clutch	<p>6) Is the leading edge of the copy paper as far as the registration roller assembly? YES: See “The registration roller fails to rotate.”</p>
Pickup assembly	<p>7) Open the right upper cover and the right lower cover. With a screwdriver fitted in the door switch, press the Start key. Does the feeding/separation roller rotate? YES: Go to step 9.</p>

Pickup clutch, DC controller PCB

- 8) **Se the meter range to 30 VDC, and connect the meter probes to the connectors of the DC controller PCB as indicated in the following table. Does the voltage change from 24 to 0 V when the Start key is pressed?**

Cassette	Clutch	+	-
Right deck	CL10	J511-A1	GND
Left deck	CL11	J518-B7	GND
3	CL12	J515-A1	GND
4	CL14	J517-A1	GND

YES: Check the wiring; if normal, replace the clutch.

NO: Replace the DC controller PCB.

Sensor, Pickup assembly

- 9) **In service mode (COPIER>I/O>IP), find out which sensor has detected the jam. Is the sensor normal?**

NO: Check the wiring and the lever; if normal, replace the sensor.

YES: Remove the pickup assembly, and check the springs and the like.

4.1.74 The lifter fails to move up

Gear lever	<p>1) Remove the deck, and move the lifter by hand. Does it move smoothly? NO: Remove the pickup assembly, and check the gear and the lever.</p>
Spring lever	<p>2) Push down the pickup roller releasing lever with your finger. Does the pickup roller move down? NO: Remove the pickup assembly, and check the spring and the lever.</p>
Deck open/closed sensor	<p>3) Is the voltage of the following connectors on the DC controller PCB about 5 V when the deck is slid in? right deck (PS25): J511-B5 left deck (PS33): J518-B2 NO: Check the sensor flag and the wiring; if normal, replace the sensor.</p>
Deck limit sensor	<p>4) Is the voltage of the following connectors on the DC controller about 0 V? right deck (PS24): J511-B8 left deck (PS34): J518-B5 NO: Check the sensor flag and the wiring; if normal, replace the sensor.</p>
Lifter motor, DC controller PCB	<p>5) Turn on the main power switch and the control panel power switch. Set the meter range to 30 VDC. Connect the - probe to ground and + probe to the connector of the DC controller PCB. Does the voltage change from about 0 V to 24 V when the deck is slid in? right deck (M13): J514-A4 left deck (M14): J514-B1 YES: Replace the deck lifter motor. NO: Replace the DC controller PCB.</p>

4.1.75 The lifter fails to move up (pickup from cassette)

Cassette size detecting switch

1) Is the size of the cassette indicated in the message display?

NO: Check the cassette size detecting switch.

Cassette (latch assembly)

2) Is the movement of the cassette open button normal?

NO: Mount it correctly.

Spring lever

3) Push up the pickup roller releasing lever with a finger. Does the pickup roller move down?

NO: Remove the pickup assembly, and check the spring and the lever.

Cassette open/closed sensor

4) Is the voltage of the following connectors on the DC controller about 5 V when the cassette is slid in?

cassette 3 (PS40): J515-B5

cassette 4 (PS45): J517-B5

NO: Check the sensor flag and the wiring; if normal, replace the sensor.

Lifter motor, DC controller PCB

5) Turn on the power switch and the control panel power switch, and set the meter range to 30 VDC. Connect the - probe to ground, and connect the + probe to the following jack. Does the voltage change from about 0 to 24 V when the cassette is slid in?

cassette 3 (M16): J516-A4

cassette 4 (M17): J516-B1

YES: Remove the lifter assembly, and check the gears and the like; if normal, replace the motor.

NO: Replace the DC controller PCB.

4.1.76 Pickup fails (multifeeder)

Wiring	<p>1) Is the connector (to the machine) of the multifeeder connected correctly? NO: Connect it correctly.</p>
-----	<p>2) Is the leading edge of paper as far as the registration roller? YES: See “The registration roller fails to rotate.”</p>
Pickup roller, Pickup/feeding roller, Separation roller	<p>3) Is the orientation of the pickup roller, pickup/feeding roller, and separation roller correct? NO: Mount them correctly.</p>
Manual feed tray paper sensor (PS17)	<p>4) Execute the following service mode. Does the bit change from 0 to 1 when paper is placed in the multifeeder assembly? COPIER>I/O>DC-CON>P004 (bit 12) NO: Check the wiring and the sensor flag; if normal, replace the sensor (PS17). (DC controller PCB J510-B7, B8, B9)</p>
Manual feed tray pickup clutch (CL7)	<p>5) Execute the following in service mode. Is the sound of the clutch (CL7) operating heard? COPIER>FUNCTION>PART-CHK>CL1 ↓ OK ↓ COPIER>FUNCTION>PART-CHK>CL-ON ↓ OK NO: Check the wiring; if normal, replace the clutch (CL7). (DC controller PCB J513-A8, A9)</p>
Manual feed tray feeding clutch (CL18)	<p>6) Execute the following. Is the sound of the clutch (CL18) operating heard? COPIER>FUNCTION>PART-CHK>CL16 ↓ OK ↓ COPIER>FUNCTION>PART-CHK>CL-ON ↓ OK NO: Check the wiring; if normal, replace the clutch (CL18). (DC controller PCB J513-A6, A7)</p>

Multifeeder pickup latch solenoid (SL6)

7) **Execute the following in service mode. Does the multifeeder pickup roller move up and down?**

COPIER>FUNCTION>PART-CHK>SL5 (up)

COPIER>FUNCTION>PART-CHK>SL6 (down)

↓
OK



COPIER>FUNCTION>PART-CHK>LS-ON



↓
OK

NO: Check the wiring and the like; if normal, replace the solenoid (SL6). (DC controller PCB J510-10-, -11, -12)

DC controller PCB

8) **Try replacing the DC controller PCB. Is the problem corrected?**

YES: End.

4.1.77 The vertical path roller fails to rotate

Belt, Gear, Coupling

- 1) **Is the drive transmitted to each vertical path roller through the belt, gear, and coupling?**

NO: Attach the belt, gear, and coupling properly.

Vertical path 1 clutch

- 2) **Execute the following in service mode. Is the sound of the clutch (CL8) heard?**

COPIER>FUNCTION>PART-CHK>CL7

↓
OK

COPIER>FUNCTION>PART-CHK>CL-ON

↓
OK

NO: Check the wiring; if normal, replace the clutch (CL8).
(DC controller PCB; J511-A3, -A4)

Vertical path 2 clutch

- 3) **Execute the following in service mode. Is the sound of the clutch (CL9) heard?**

COPIER>FUNCTION>PART-CHK>CL9

↓
OK

COPIER>FUNCTION>PART-CHK>CL-ON

↓
OK

NO: Check the wiring; if normal, replace the clutch (CL9).
(DC controller PCB; J514-A6, A7)

Vertical path 3 clutch

- 4) **Execute the following in service mode. Is the sound of the clutch (CL13) heard?**

COPIER>FUNCTION>PART-CHK>CL3

↓
OK

COPIER>FUNCTION>PART-CHK>CL-ON

↓
OK

NO: Check the wiring; if normal, replace the clutch (CL13).
(DC controller PCB; J515-A3, -A4)

Vertical path 4 clutch, DC controller PCB

5) **Execute the following in service mode. Is the sound of the clutch (CL15) heard?**

COPIER>FUNCTION>PART-CHK>CL5



OK



COPIER>FUNCTION>PART-CHK>CL-ON



OK

NO: Check the wiring; if normal, replace the clutch (CL15).
(DC controller PCB; J517-A3, -A4)

YES: Replace the DC controller PCB.

4.1.78 The registration roller fails to rotate

Belt, Gear, Coupling

- 1) **Is the drive of the main motor (M1) transmitted to the registration roller through the belt, gear, and coupling?**

NO: Attach the belt, gear, and coupling properly.

Registration paper sensor (PS5)

- 2) **Execute the following in service mode. Does the state of bit 11 change from '0' to '1' when paper is placed over the registration paper sensor?**

COPIER>I/O>DC-CON>P001

NO: Check the wiring and the sensor flag; if normal, replace the sensor.
(DC controller PCB, J509-A1, -A2, -A3)

Registration clutch (CL2), DC controller PCB

- 3) **Execute the following in service mode. Is the sound of the clutch (CL2) heard?**

COPIER>FUNCTION>PART-CHK>CL19

↓
OK

COPIER>FUNCTION>PART-CHK>CL-ON

↓
OK

NO: Check the wiring; if normal, replace the clutch (CL2).
(DC controller PCB, J509 A4, A5)

YES: Replace the DC controller PCB.

4.1.79 The No. 1 mirror base fails to move

Copyboard glass

- 1) Is the copyboard glass mounted correctly?**
 NO: Mount the copyboard glass so that the copyboard glass sensor (PS57) is actuated correctly.

Copyboard glass sensor (PS57)

- 2) Measure the voltage of J804-2 of the scanner motor driver. Is it as follows?**
- with the copyboard glass mounted, 5 V
 - with the copyboard glass removed, 0 V
- NO: If the voltage remains unchanged when the sensor is pushed by hand and, in addition, the wiring is normal, replace the sensor.

Cable (broken, displaced)

- 3) Is the cable used to drive the scanner strung correctly?**
 NO: String the cable correctly.

Scanner path (foreign matter)

- 4) Is the scanner rail free of dirt and does the scanner move smoothly when pushed by hand?**
 NO: Check the surface of the scanner rail for dirt and foreign matter and for an object that comes into contact with the scanner; as necessary, clean, lubricate, or repair.
 Reference: If the rail is soiled, clean it with alcohol, and apply a small amount of silicone oil (FY9-6010).

Relay PCB

- 5) Measure the voltage of J801 on the scanner motor driver PCB.**
- J801-1: 38 V
 - J801-3: 12 V
 - J801-5: -12 V
 - J801-6: 5 V
- NO: Check the AC line up to the relay PCB; if normal, replace the relay PCB.

Reader controller PCB

- 6) Measure the voltage of J1109-A12 on the reader controller PCB. Is it as follows?**
- with the control panel power switch ON, changing from 0 to 5 V
- NO: If the wiring is normal, replace the reader controller PCB.

Scanner motor driver PCB, Scanner motor (M5)

- 7) Try replacing the scanner motor driver PCB. Is the problem corrected?**
 YES: End.
 NO: Replace the scanner motor (M5).

4.1.80 The pre-exposure lamp fails to go ON

Pre-exposure lamp PCB

- 1) **Select the following in service mode: COPIER>I/O>IP. Does the state of bit 0 at address P016 change from '0' to '1' when the Start key is pressed?**
 YES: Check the wiring from DC controller PCB to the pre-exposure lamp PCB; if normal, replace the pre-exposure lamp.

DC controller PCB, Pre-exposure lamp PCB

- 2) **Set the meter range to 300 VDC. Does the voltage between J504-A1 (+) on the DC controller PCB and GND change from 0 to 24 V when the Start key is pressed?**
 NO: Replace the DC controller PCB.
 YES: Check the wiring from the DC controller PCB to the pre-exposure lamp PCB; if normal, replace the pre-exposure lamp PCB.

4.1.81 The scanning lamp fails to go ON

Connector

- 1) **Make the following selections in service mode: COPIER>FUNCTION>MISC-R>SCANLAMP. Does the scanning lamp remain ON for 3 sec when the OK key is pressed?**
 YES: The connector may have poor contact. Check the connector.

Lamp

- 2) **Is the scanning lamp (LA1) mounted correctly?**
 NO: Disconnect the power plug from the power outlet, and mount the lamp correctly.

Relay PCB

- 3) **Measure the voltage of J1001-1 on the inverter PCB. Is it 38 V?**
 NO: Check the AC line up to the relay PCB; if normal, replace the relay PCB.

Inverter PCB, Reader controller PCB

- 4) **Measure the voltage of J1109-B11 on the reader controller PCB. Does it change from 5 to 0 V when the control panel power switch is tuned on?**
 YES: If the wiring is normal, replace the inverter PCB.
 NO: If the wiring is normal, replace the DC controller PCB.

4.1.82 The toner feed motor (M6) inside the cartridge fails to operate

-----	<p>1) Execute the following in service mode: COPIER>FUNCTION>PART-CHK>MTR. Does the toner feed motor inside the cartridge rotate? NO: Go to step 3).</p>
DC controller PCB, Connectors (J243, J245)	<p>2) Execute the following service mode to turn on the hopper motor: COPIER>FUNCTION>PART-CHK>MTR. Is the voltage between J512-B4 (+) and J512-B5 (-) on the DC controller PCB 24 V? NO: Replace the DC controller PCB. YES: Check the connection of the relay connectors J243 and J245.</p>

4.1.83 The feed motor (M18) inside the hopper fails to operate

-----	<p>1) Execute the following in service mode: COPIER>FUNCTION>PART-CHK>MTR. Does the toner feed motor inside the hopper rotate? NO: Go to step 3.</p>
DC controller PCB, Connector (J138, J143)	<p>2) Execute the following in service mode: COPIER>FUNCTION>PART-CHK>MTR. Is the voltage between J504-B12 (-) and J504-B13 (-) on the DC controller PCB about 24 V? NO: Replace the DC controller PCB. YES: Check the connection of the relay connectors (J138, J143).</p>

4.1.84 The drum heater fails to operate

-----	<p>1) Open the front door, and release the fixing/feeding assembly. Are the ends of the drum warm? (Do not touch the surface of the drum.)</p> <p>YES: The drum heater is operating.</p>
DC controller PCB	<p>2) Set the meter range to 12 VDC. Connect the probes to J505-A7 (-) and J505-A8 (-) on the DC controller PCB. Is the voltage across the terminals 5 V in standby?</p> <p>NO: Replace the DC controller PCB.</p>
AC driver PCB	<p>3) Try replacing the AC driver PCB. Is the problem corrected?</p> <p>YES: End.</p>
Drum heater (H3), drum heater controller PCB	<p>4) Remove the drum. Set the meter range to Wx1. Does the index of the meter swing when the probes are connected to both terminals of the heater?</p> <p>NO: Replace the drum heater.</p> <p>YES: Replace the drum heater controller PCB.</p>

4.1.85 The Add Toner message fails to go ON

-----	<p>1) Is toner inside the hopper assembly?</p> <p>NO: Go to step 2.</p>
Toner sensor (hopper assembly), DC controller PCB, DC controller PCB/control panel	<p>2) Make the following selections in service mode: COPIER>I/O>DC-CON. Spread apart the toner to expose the toner sensor (TS1). At this time, is the state of bit 0 at address P003 '0' (absence of toner)?</p> <p>NO: 1. Replace TS1. 2. Replace the DC controller PCB.</p> <p>YES: 1. Replace the DC controller PCB. 2. Replace the control panel.</p>

4.1.86 The Add Toner message fails to go ON

Toner	<p>1) Is toner present at the rear of the hopper assembly? NO: The toner level inside the hopper is low. Replenish the hopper with toner.</p>
Toner sensor (TS1), DC controller PCB/control panel	<p>2) Make the following selections in service mode: COPIER>I/O>DC-CON. At this time, is the state of bit 0 of address P003 '0' (absence of toner)? YES: Replace the toner sensor (TS1) of the hopper assembly. NO: 1. Replace the DC controller PCB. 2. Replace the control panel.</p>

4.1.87 The Set Card Reader message fails to go ON

Card reader	<p>1) Check to see that the card reader has been installed. Enter '1' using the following service mode: COPIER>FUNCTION>INSTALL>CARD. Turn off and then on the power switch. Does the message go ON? YES: Check the connector of the card reader for a short circuit.</p>
Control panel, Main controller PCB	<p>2) Try replacing the control panel. Does the message go ON? YES: End. NO: Replace the main controller PCB.</p>

4.1.88 The Set Control Card message fails to go OFF

Card	<p>1) Is a card fitted to the card reader correctly? NO: Fit the card correctly.</p>
Main controller PCB, Card reader	<p>2) Can copies be made? NO: Replace the main controller PCB. YES: Replace the card reader.</p>

4.1.89 The Add Paper message fails to go OFF (deck light/left)

Deck paper sensor (deck right, PS22; deck left, PS32)

- 1) **Is the deck paper sensor mounted correctly? Also, is the movement of the sensor flag normal?**

NO: Mount the sensor correctly.

4.1.90 The Add Paper message fails to go OFF (cassette 3/4)

Cassette paper sensor (cassette 3, PS39; cassette 4, PS44)

- 1) **Is the cassette paper sensor mounted correctly? Is the movement of the sensor flag normal?**

NO: Mount the sensor correctly.

Cassette pickup assembly

- 2) **Is the gear engagement between the output gear of the lifter motor and the gear in the cassette pickup assembly faulty?**

YES: Mount the lifter motor correctly. Or, replace the lifter motor and the cassette pickup assembly at the same time.

4.1.91 The fixing heater fails to operate

Multimeter cover

1) Is the multifeeder cover closed firmly?

NO: Close the multifeeder cover firmly.

Multifeeder cover open/closed sensor (PS56)

2) Is the multifeeder cover open/closed sensor mounted correctly?

NO: Mount the multifeeder open/closed correctly.

YES: Replace the multifeeder open/closed sensor.

Fixing/feeding unit releasing lever sensor (PS28)

3) Is the fixing/feeding unit releasing lever sensor mounted correctly?

NO: Mount the fixing/feeding unit releasing lever sensor.

YES: Replace the fixing/feeding unit releasing lever sensor.

Thermal switch (TP1)

4) Slide out the fixing assembly, and connect the meter probes across both terminals of the thermal switch (TP1). Is there electrical continuity?

NO: Replace the thermal switch unit.

Fixing heater (H1, H2)

5) Slide out the fixing assembly, and connect the meter probes across both terminals of the fixing heater (H1, H2). Is there electrical continuity?

NO: Replace the fixing heater.

AC driver PCB, DC controller PCB

6) Is the voltage of the following connectors on the DC controller PCB about 5 V?

Heater	(+)
Main heater (H1)	J505-A11
Sub heater (H2)	J505-A13

YES: Replace the AC driver PCB.

NO: Replace the DC controller PCB.

4.1.92 Pickup fails (side paper deck)

Right upper door, Right lower door	<p>1) Are the right upper door and the right lower door closed firmly? NO: Close the doors firmly.</p>
Lifter	<p>2) Does the lifter move down when the compartment is slid out from the deck? Also, is the sound of the lifter move up heard when the compartment is slid in? NO: See “The deck lifter fails to move up.”</p>
Deck pickup roller	<p>3) Does the pickup roller rotate? YES: If the roller is soiled, clean it with alcohol. If it is deformed because of wear, replace it.</p>
Belt (displacement)	<p>4) Is the belt used to transmit drive to the pickup roller attached correctly? NO: Attach the belt correctly.</p>
Drive belt, Gear, Coupling	<p>5) Is the drive from the deck main motor transmitted to the pickup assembly through the drive belt, gear, and coupling? NO: Check the drive belt, gear, and coupling.</p>
Side deck driver PCB output, Deck pickup/vertical path clutch (pickup, CL102; feed, CL101)	<p>6) Measure the voltage of the following connectors on the side deck PCB. Does it change from 24 to 0 V when the Start key is pressed?</p> <ul style="list-style-type: none"> • J104-7 (CL101) • J104-12 (CL102) <p>NO: Replace the side deck driver PCB. YES: Check the wiring up to the clutch; if normal, replace the clutch.</p>

4.1.93 The deck lifter fails to move up (side paper deck)

Side paper deck	<p>1) It the deck mounted correctly? NO: Mount the deck correctly.</p>
Lifter cable	<p>2) Is the lifter cable strung correctly? NO: String the lifter cable correctly.</p>
Spring, Lever	<p>3) Push up the pickup roller releasing lever with your finger. Does the pickup roller move down? NO: Remove the pickup assembly, and check the spring and lever.</p>
Deck lifter motor (M102)	<p>4) Does the deck lifter motor rotate? YES: Go to step 6.</p>
Deck lifter driver PCB, Deck open detecting switch (SW101)	<p>5) Does the voltage between J109-3 on the side deck driver PCB and GND (-) change from about 0 to 5 V when the deck is closed? NO: Replace the side deck driver PCB. YES: Check the wiring up to the switch; if normal, replace the switch.</p>
Deck lifer lower limit switch (SW102), Side deck driver PCB	<p>6) Is the voltage between J107-8 (-) note side deck driver PCB and GND (-) as follows?</p> <ul style="list-style-type: none"> • When the deck is opened, 0 V. • When the deck is closed, 5 V. <p>YES: Check the lever and wiring; if normal, replace the sensor. NO: Replace the side deck driver PCB.</p>

5 Troubleshooting Feeding Problems

5.1 Copy Paper Jams

Jams occurring inside the machine may be grouped according to their locations as follows:

1. pickup assembly
2. separation/feeding assembly
3. fixing/delivery assembly
4. drum cleaner assembly
5. holding tray assembly
6. feeding assembly

The descriptions that follow are also given in reference to the locations of jams. The location or type of jam may be checked in service mode (COPIER>DISPLAY>JAM).

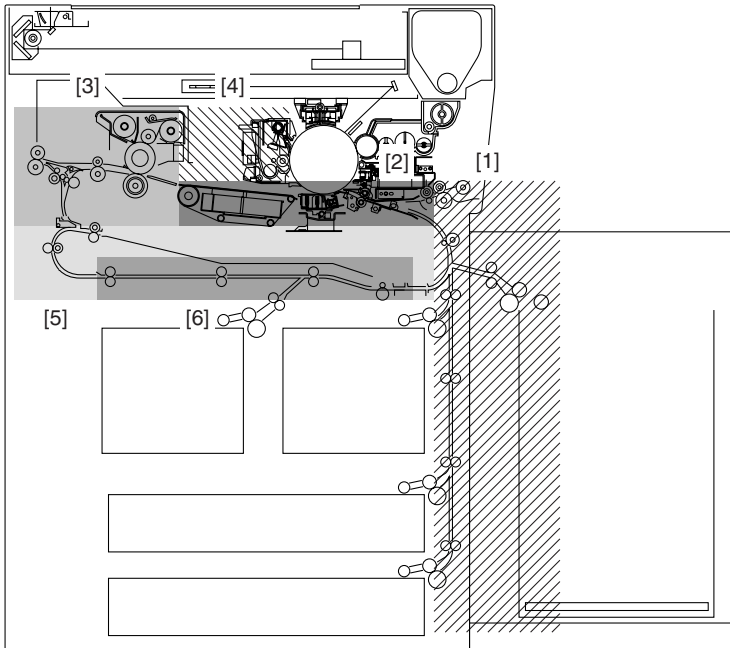

F06-501-01

5.1.1 Pickup Assembly

Delivery assembly

1) Is the copy paper curled or wavy?

YES: Replace the paper. Advise the user on the correct method of storing paper.

2) Try paper of a recommended type. Is the problem corrected?

YES: Advise the user to use recommended paper.

DC controller PCB, Pickup clutch

3) During copying, does the pickup roller of the selected source of paper (cassette, deck, manual feed tray) rotate?

NO: See "Pickup fails" for each source of paper.

Pickup roller, Guide plate, Optical sensor (prism)

4) Is the pickup roller deformed or worn?

YES: Replace the pickup roller.

NO:

- Check the guide plate for deformation.
- Check the prism for dirt. If soiled, clean it with a blower brush. (If the dirt cannot be removed, dry wipe with lint-free paper.)

5.1.2 Separation/Feeding Assembly

Copy paper	<p>1) Is the leading edge of the copy paper past the registration roller? YES: Go to step 5.</p>
Registration roller	<p>2) Is the coupling of the registration roller connected correctly? NO: Mount the fixing/feeding unit correctly.</p> <p>3) Is the registration roller deformed because of wear or soiled? YES: If soiled, clean it with alcohol; if deformed, replace it.</p> <p>4) Are the retaining springs on both ends of the registration roller mounted correctly? NO: Mount them correctly. YES: Check the transfer guide for foreign matter and deformation.</p>
Registration clutch	<p>5) Is the operation of the registration clutch normal? NO: Check the registration clutch.</p>
Transfer/separation charging assembly	<p>6) Is the transfer/separation charging assembly fitted firmly? YES: Check the transfer/separation charging assembly.</p> <p>7) Are there burrs on the paper guide of the transfer/separation charging assembly? YES: Remove the burrs.</p>
Copy paper	<p>8) Try paper of a recommended type. Is the problem corrected? YES: Advise the user to use recommended paper.</p>
Separation claw (cleaner assembly)	<p>9) Is the serration claw found under the cleaner assembly damaged? YES: Replace the separation claw.</p>
Feeding belt, Feed fan	<p>10) Are the two feeding belts moving correctly? NO: Check the belt and the pulley. YES: Check the feed fan to see if it is operating.</p>

5.1.3 Fixing Assembly, Delivery Assembly

Separation claw (delivery assembly)	<p>1) Is the separation claw worn/deformed? YES: 1. Replace the separation claw. 2. If soiled, clean it with solvent.</p>
Fixing assembly, Upper/lower roller	<p>2) Is the upper/lower roller deformed or damaged? YES: Replace the roller.</p>
Paper guide	<p>3) Is the paper guide soiled with toner? YES: Clean it with solvent.</p>
Nip	<p>4) Is the height of the paper guide correctly? NO: Correct the height.</p> <p>5) Is the lower roller pressure (nip) as indicated? NO: Correct it.</p>
Delivery assembly, Web	<p>6) Is the web taken up correctly? NO: Check the fixing cleaner assembly.</p>
Sensor lever	<p>7) Does each sensor lever move smoothly? NO: Adjust the lever so that it moves smoothly.</p>
Delivery sensor	<p>8) Are the external delivery sensor (PS10) and the claw jam sensor (PS6) normal? NO: Replace the sensor.</p>
Delivery reflecting plate	<p>9) Is the delivery reflecting plate oriented in the direction of delivery? NO: Correct the orientation of the delivery reflecting plate.</p>
Leading edge margin, Delivery roller drive assembly	<p>10) Does the delivery roller move smoothly? NO: Check the delivery roller drive assembly. YES: Check the leading edges of copies for a margin. (3.0 mm or more)</p>

5.1.4 Fixing assembly, Delivery assembly (reversal delivery assembly)

Duplex reversal sensor (PS12)

1) Is the duplex reversal sensor (PS12) normal?

NO: Replace the sensor.

Internal delivery sensor (PS9)

2) Is the internal delivery sensor (PS9) normal?

NO: Replace the sensor.

Delivery flapper solenoid (SL3)

3) Does the delivery flapper move correctly?

NO: Adjust the position of the delivery flapper solenoid, or replace it.

Reversing flapper solenoid (SL11)

4) Does the reversing flapper move correctly?

NO: Adjustment position of the reversal flapper solenoid, or replace it.

Reversal motor (M11)

5) Does the reversal motor (M11) rotate at the correct timing?

NO: Replace the reversal motor (M11).

YES: If the timing belt is worn or torn, replace it. If it is slack or displaced, attach it correctly.

5.1.5 Cleaner assembly

Transfer/separation charging assembly, Pre-transfer charging assembly

1) Is the transfer/separation charging assembly and the pre-transfer charging assembly fitted correctly?

NO: Fit the transfer/separation charging assembly and the pre-transfer charging assembly correctly.

2) Is the height of the charging wire as indicated?

NO: Correct the height of the charging wire.

Separation claw (cleaning assembly)

3) Is the separation claw found under the cleaner assembly damaged?

YES: Replace the separation claw.

Copy paper, High-voltage transformer, DC controller PCB

4) Try paper of a recommended type. Is the problem corrected?

YES: Advise the user to use recommended paper.

NO: 1. Check the high-voltage transformer.
2. Check the DC controller PCB.

5.1.6 Lower Feeding Assembly

-----	1) Is the lower feeding assembly fitted correctly? NO: Fit it correctly.
Lower feeding middle clutch (CL16), Lower feeding right clutch (CL17)	2) Does the roller inside the lower feeding assembly rotate correctly? NO: Replace the CL16 or CL17.
Pre-confluence sensor (PS14), Post-confluence sensor (PS15)	3) Are the pre-confluence sensor (PS14) and the post-confluence sensor (PS15) normal? NO: Replace PS14 or PS15.

5.2 Feeding Faults

5.2.1 Double Feeding

Separation roller, Spring

1) Is the separation roller deformed or worn?

YES: Replace the separation roller.

NO: Replace the spring used to pull the separation roller.

5.2.2 Wrinkles

Pickup assembly

1) Turn off the power while copy paper is moving through the feeding assembly. At this time, is the copy paper wrinkled? Or, is it moving askew?

YES: Check the pickup assembly. Check the registration roller.

Cop paper

2) Try paper fresh out of package. Is the problem corrected?

YES: The paper is likely to be moist. Advise the user on the correct method of storing paper.

3) Try paper of a recommended type. Is the problem corrected?

YES: Advise the user to use recommended paper.

Fixing assembly, Paper guide

4) Is the paper guide soiled with foreign matter (e.g., toner)?

YES: Clean it with solvent.

5) Is the height of the paper guide correct?

NO: Adjust the height of the paper guide.

Lower roller pressure, Upper/lower roller pressure

6) Is the lower roller pressure (nip) as indicated?

NO: Adjust it.

YES: Try replacing the upper and lower rollers one after the other.

6 Arrangement and Function of Electrical Parts

6.1 Clutches

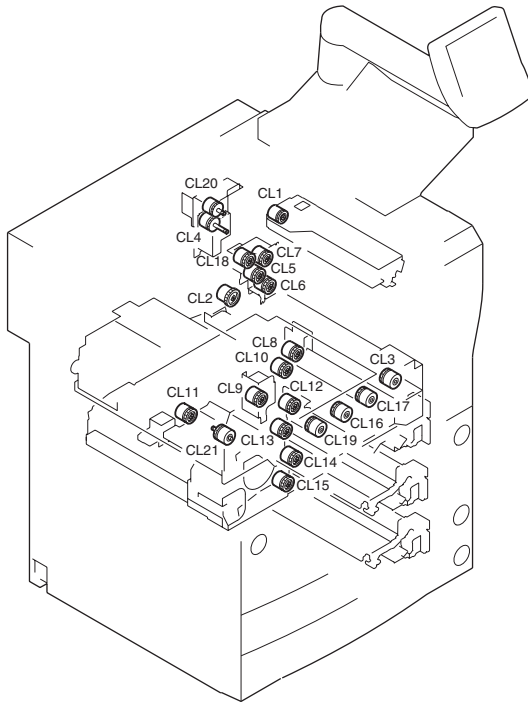

F06-601-01

Name	Notation	Function
Inside hopper magnet roller drive clutch	CL1	Drives the inside hopper magnet roller.
Registration clutch	CL2	Drives the registration roller.
Registration brake clutch	CL3	Drives the registration brake.
Development 1 clutch	CL4	Drives the developing cylinder (1).
Pre-registration clutch	CL5	Drives the pre-registration roller.
Pre-registration brake clutch	CL6	Drives the pre-registration brake.
Manual feed tray pickup clutch	CL7	Drives the manual feed tray pickup roller.
Vertical path 1 clutch	CL8	Drives the vertical path 1 roller.
Vertical path 2 clutch	CL9	Drives the vertical path 2 roller.
Deck (right) pickup clutch	CL10	Drives the deck (right) pickup roller.
Deck (left) pickup clutch	CL11	Drives the deck (left) pickup roller.
Cassette 3 pickup clutch	CL12	Drives the cassette 3 pickup roller.
Vertical path 3 clutch	CL13	Drives the vertical path 3 roller.
Cassette 4 pickup clutch	CL14	Drives the cassette 4 pickup roller.
Vertical path 4 clutch	CL15	Drives the vertical path 4 roller.
Lower feeder middle clutch	CL16	Drives the lower feeder middle roller.
Lower feeder right clutch	CL17	Drives the lower feeder right roller.
Manual feed tray feeding clutch	CL18	Drives the manual feed tray drive roller.
Deck (left) feeding clutch	CL19	Drives the deck (left) feeding roller.
Developing 2 clutch	CL20	Drives the developing cylinder (2).
Delivery speed switching clutch	CL21	Switches delivery speed.

T06-601-01

6.2 Solenoids

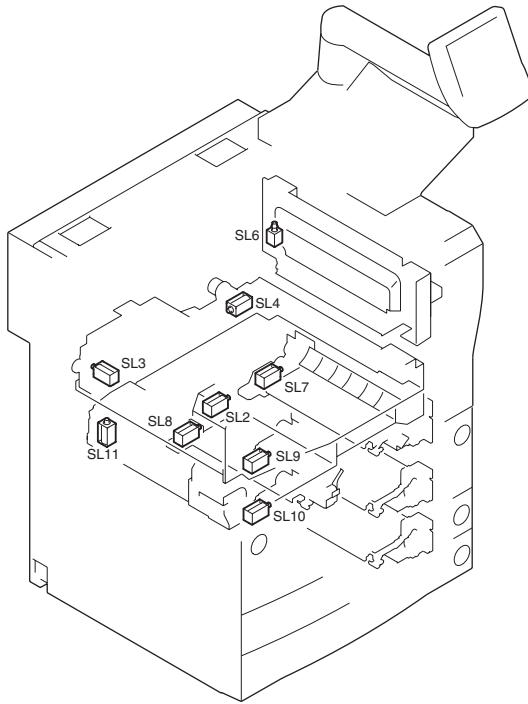

F06-602-01

Name	Notation
Fixing web solenoid	SL2
Delivery flapper solenoid	SL3
Fixing/feeder unit locking solenoid	SL4
Manual feed pickup latch solenoid	SL6
Deck (right) pickup solenoid	SL7
Deck (left) pickup solenoid	SL8
Cassette 3 pickup solenoid	SL9
Cassette 4 pickup solenoid	SL10
Reversing flapper solenoid	SL11

T06-602-01

6.3 Motors

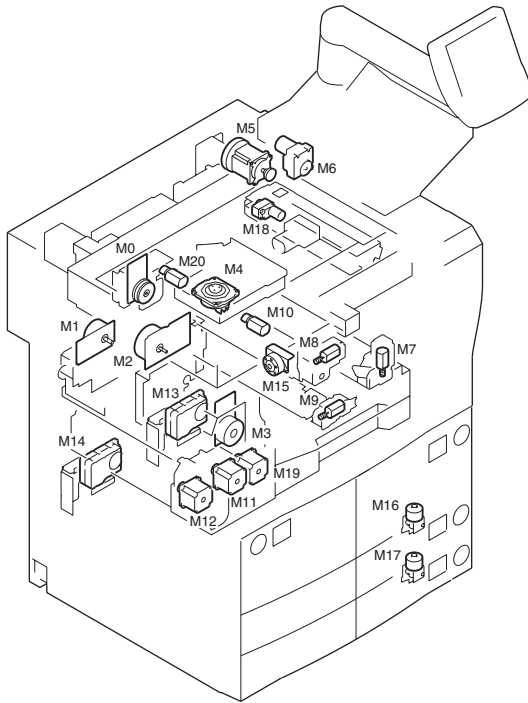

F06-603-01

Name	Notation
Drum motor	M0
Main motor	M1
Pickup motor	M2
Fixing motor	M3
Laser scanner motor	M4
Scanner motor	M5
Inside cartridge toner feeder motor	M6
Pre-transfer charging wire cleaner motor	M7
Primary charging wire cleaner motor	M8
Transfer/separation charging wire cleaner motor	M9
Vibration motor	M10/M20
Duplex reversal motor	M11
Duplex feeder motor (left)	M12
Deck (right) lifter motor	M13
Deck (left) lifter motor	M14
Horizontal registration motor	M15
Cassette 3 lifter motor	M16
Cassette 4 lifter motor	M17
Inside hoper toner feeder motor	M18
Duplex feeder motor (right)	M19

T06-603-01

6.4 Fans

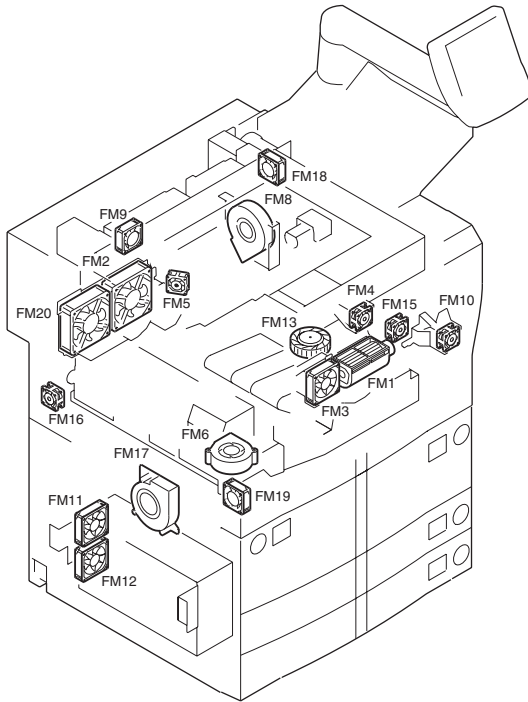

F06-604-01

Name	Notation
Laser motor cooling fan	FM1
Fixing heat discharge fan	FM2
Laser cooling fan 1	FM3
Stream reading fan	FM4
Laser cooling fan 2	FM5
Curl-reducing fan	FM6
Drum fan	FM8
Inverter cooling fan	FM9
Pre-transfer charging assembly fan	FM10
Power supply cooling fan 1	FM11
Power supply cooling fan 2	FM12
Separation fan	FM13
Developing fan	FM15
System fan	FM16
Delivery anti-adhesion fan	FM17
Scanner motor cooling fan	FM18
Duplex feeder fan	FM19
Separation heat discharge fan	FM20

T06-604-01

6.5 Sensor 1

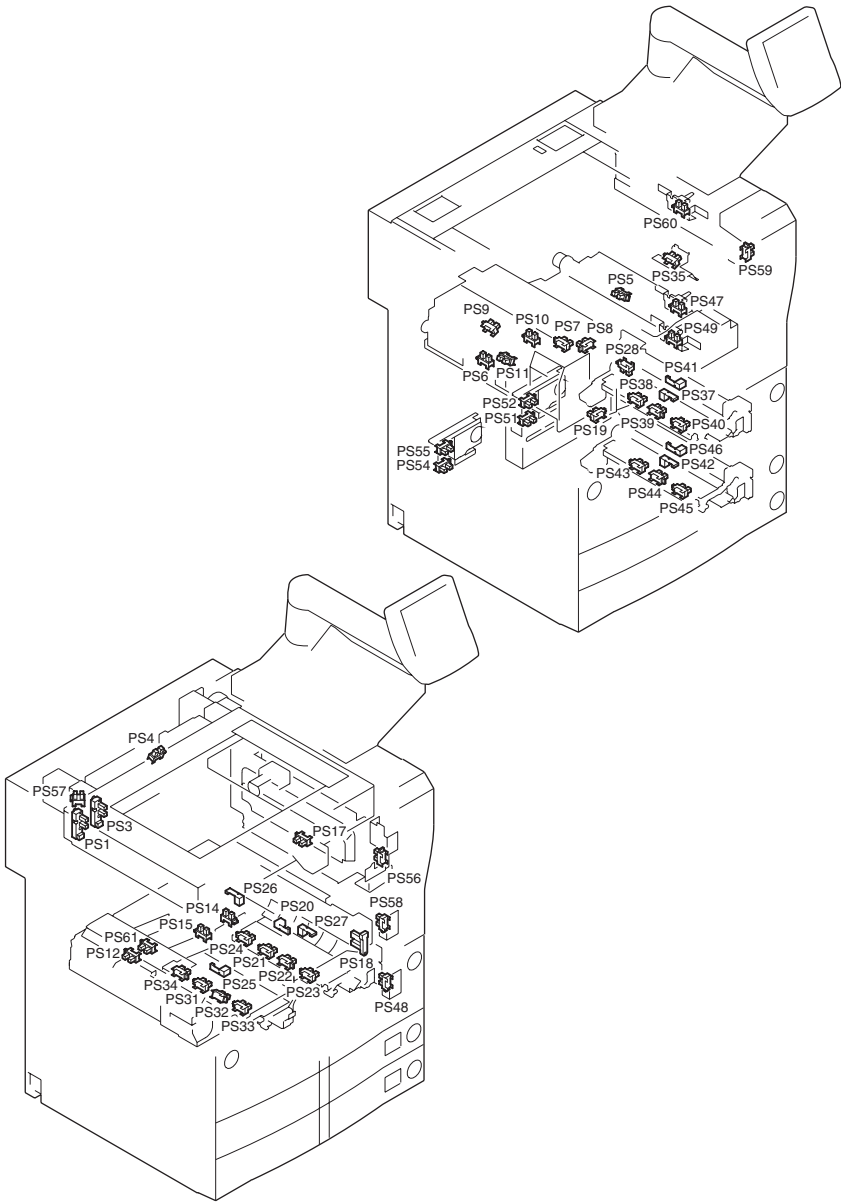

F06-605-01

Name	Notation
Scanner home position sensor	PS1
Image leading edge sensor	PS3
Copyboard cover open/closed sensor	PS4
Registration paper sensor	PS5
Fixing cable jam sensor	PS6
Fixing web length sensor	PS7
Fixing web length warning sensor	PS8
Internal delivery sensor	PS9
External delivery sensor	PS10
Fixing/feeder unit outlet sensor	PS11
Duplex reversal sensor	PS12
Pre-confluence sensor	PS14
Post-confluence sensor	PS15
Manual feed tray paper sensor	PS17
Horizontal registration sensor	PS18
Waste toner case full sensor	PS19
Right deck pickup sensor	PS20
Right deck lifter sensor	PS21
Right deck paper sensor	PS22
Right deck open/closed sensor	PS23
Right deck limit sensor	PS24
Left deck pickup sensor	PS25
Left deck feed sensor	PS26
Right deck feed sensor	PS27
Fixing/feeder unit releasing lever sensor	PS28
Left deck lifter sensor	PS31
Left deck paper sensor	PS32
Left deck open/closed sensor	PS33
Left deck open/closed sensor	PS34
Manual feed feeder inlet sensor	PS35
Cassette 3 pickup sensor	PS37
Cassette 3 lifter sensor	PS38
Cassette 3 paper sensor	PS39
Cassette 3 open/closed sensor	PS40
Vertical path 3 paper sensor	PS41
Cassette 4 pickup sensor	PS42
Cassette 4 lifter sensor	PS43
Cassette 4 paper sensor	PS44
Cassette 4 open/closed sensor	PS45
Vertical path 4 paper sensor	PS46
Vertical path 1 paper sensor	PS47
Right lower cover open/closed sensor	PS48
Vertical path 2 paper sensor	PS49
Right deck paper level medium sensor	PS51
Right deck paper level upper sensor	PS52
Left deck paper level medium sensor	PS54
Left deck paper level upper sensor	PS55
Manual feed tray cover open/closed sensor	PS56
Copyboard glass sensor	PS57
Right upper cover open/closed sensor	PS58
Toner cartridge cover open /closed sensor	PS59
Image write start sensor	PS60
Duplex outlet sensor	PS61

T06-605-01

6.6 Sensor 2

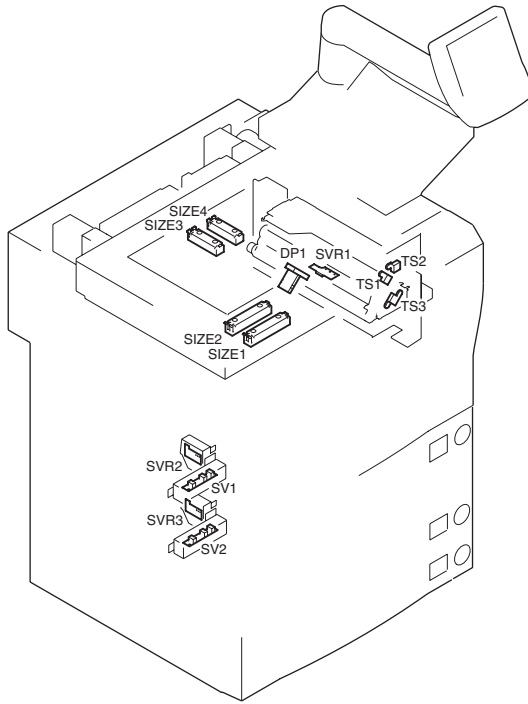

F06-606-01

Name	Notation
Original size sensor 1	SIZE1
Original side sensor 2	SIZE2
Original side sensor 3	SIZE3
Original size sensor 4	SIZE4
Cassette 3 paper length sensor	SV1
Cassette 4 paper length sensor	SV2
Manual feed tray paper width detecting volume	SVR1
Cassette 3 paper width detecting volume	SVR2
Cassette 4 paper width detecting volume	SVR3
Inside hopper toner sensor	TS1
Inside hopper toner lower limit sensor	TS2
Inside developing assembly toner sensor	TS3
Potential sensor	DP1

T06-606-01

6.7 Switches

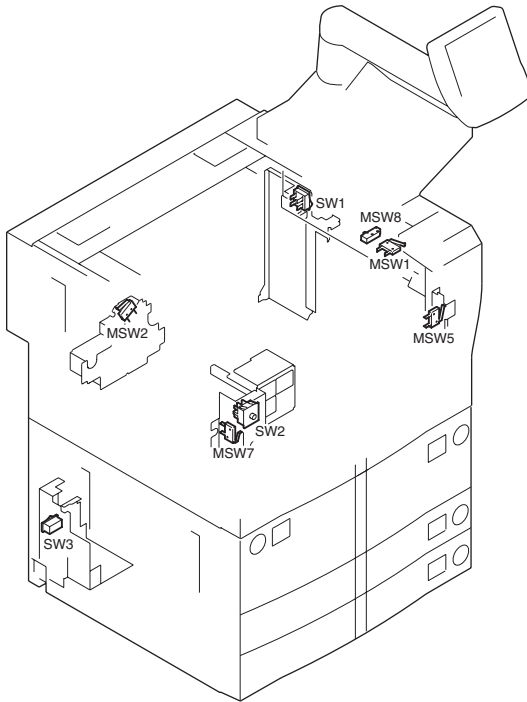

F06-607-01

Name	Notation
Main switch	SW1
Front cover switch	SW2
Drum heater switch	SW3
Cartridge detecting switch	MSW1
Waste toner clog detecting switch	MSW2
Manual feed tray cover open/ closed detecting switch	MSW5
Front cover open/closed detecting switch	MSW7
Cartridge motor drive switch	MSW8

T06-607-01

6.8 Counters, There, Fuses, and Others

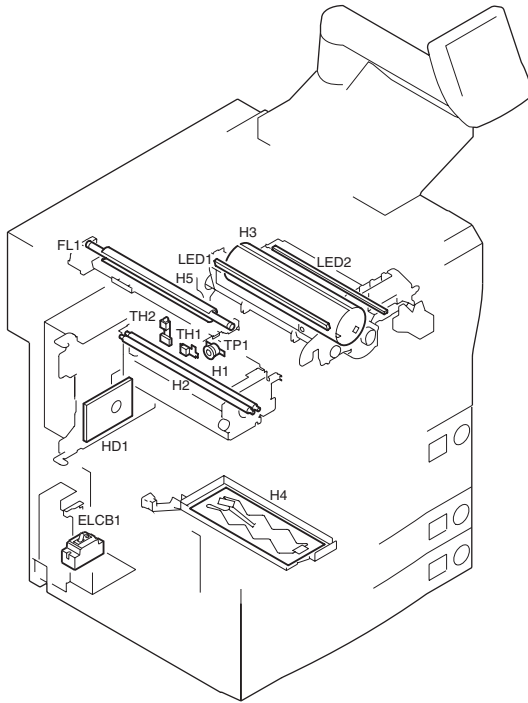

F06-608-01

Name	Notation	Description
Scanning lamp (fluorescent lamp)	FL1	Scanning lamp
Heater	H1	Fixing main heater
	H2	Fixing sub heater
	H3	Drum heater
	H4	Cassette heater
	H5	Scanning amp heater
Thermistor	TH1	Fixing heater main thermistor
	TH2	Fixing heater sub thermistor (edge)
Thermal switch	TP1	Fixing heater thermal switch
Leakage breaker	ELCB1	Leakage breaker
Pre-exposure lamp	LED1	Drum pre-exposure
Pre-transfer exposure lamp	LED2	Pre-transfer exposure
Hard disk	HD1	Hard disk

T06-608-01

6.9 PCBs

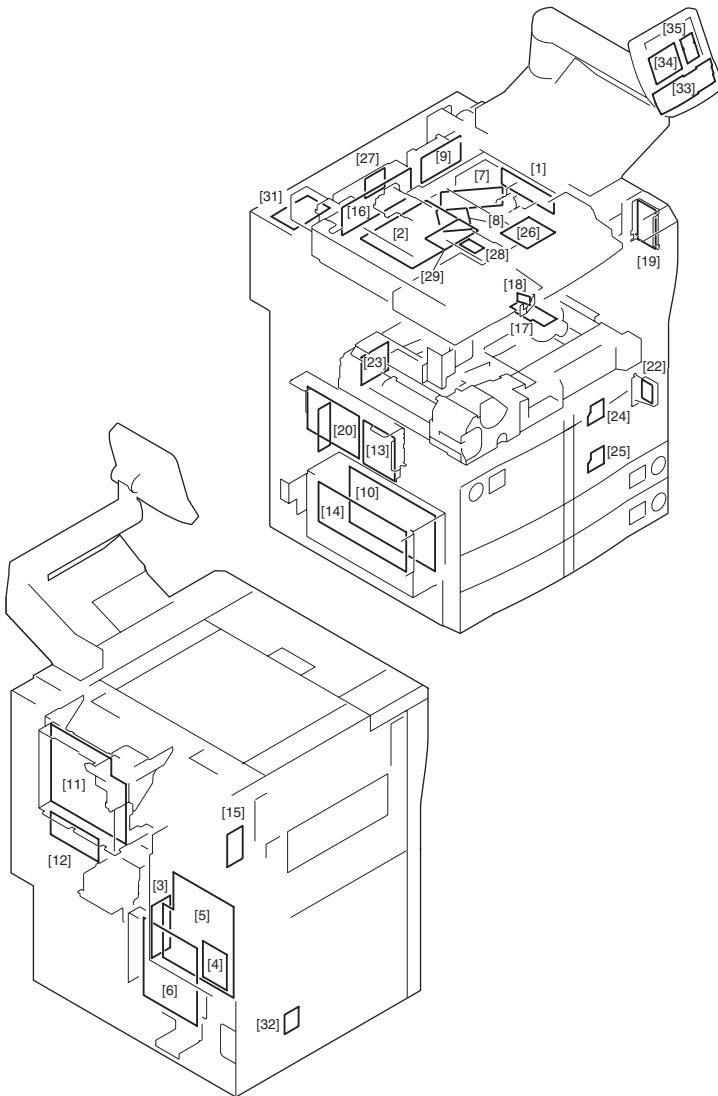

F06-609-01

Name	Notation	Function
CCD/AP PCB	PCB1	Drives the CCD/processes analog images.
Reader controller PCB	PCB2	Controls the reader unit.
Pixel/line conversion PCB	PCB3	Executes pixel/line conversion.
Differential PCB	PCB4	Executes communication signal conversion.
Main controller PCB	PCB5	Controls the system.
DC controller PCB	PCB6	Controls the printer unit.
Laser driver PCB 1	PCB7	Drives the laser diode.
Laser driver PCB 2	PCB8	Controls the laser intensity.
Scanner motor drive PCB	PCB9	Drives the scanner motor.
DC power supply PCB	PCB10	Supplies DC power.
HV-DC PCB	PCB11	Generates high-voltage DC components.
HV-AC PCB	PCB12	Generates high-voltage AC components.
All-day power supply PCB	PCB13	Supplies DC power.
Relay PCB	PCB14	Distributes DC power supply.
Bi-Centronics PCB	PCB15	Serves as a download interface.
Fluorescent lamp inverter PCB	PCB16	Controls the activation of the fluorescent lamp.
Drum heater control PCB	PCB17	Drives the drum heater.
BD PCB	PCB18	Detects the laser beam.
Potential control PCB	PCB19	Controls the drum surface potential.
AC driver PCB	PCB20	Drive the fixing heater.
Environment sensor PCB	PCB22	Detects the machine outside temperature/humidity.
Stackless feeder driver PCB	PCB23	Drives the duplex/feeder unit.
Cassette 3 paper level detection PCB	PCB24	Detects the level of paper in the cassette 3.
Cassette 4 paper level detection PCB	PCB25	Detects the level of paper in the cassette 4.
Laser scanner motor drive PCB	PCB26	Drives the laser scanner motor.
Light adjustment control PCB	PCB27	Controls the intensity of the fluorescent lamp.
Light adjustment sensor PCB	PCB28	Detects the intensity of the fluorescent lamp.
Original orientation detection PCB	PCB29	Detects the orientation of the original.
Transformer PCB	PCB31	Supplies inverter power.
Capacitor PCB (200V model only)	PCB32	Prevents electrical noise
Controls panel CPU PCB	PCB33	Controls the control panel.
Control panel PCB	PCB34	Controls panel key inputs and LED indications.
Control panel inverter PCB	PCB35	Controls the activation of the LCD.

T06-609-01

6.10 Side Paper Deck-N1

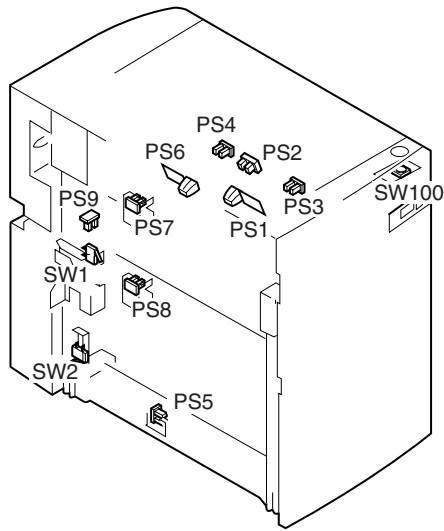

F06-610-01

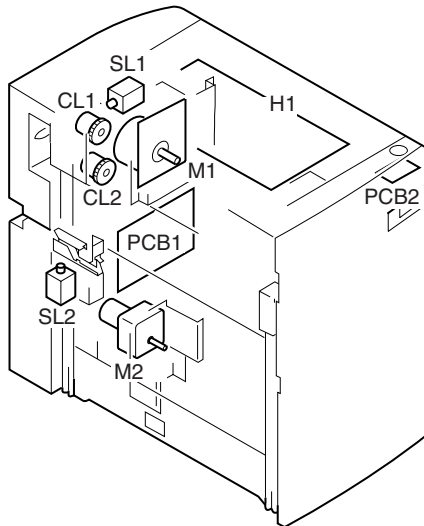

F06-610-02

Name	Notation
Deck pickup sensor	PS1
Deck paper absent sensor	PS2
Deck lifter upper limit sensor	PS3
Deck lift position sensor	PS4
Deck set sensor	PS5
Deck feed sensor	PS6
Deck paper supply position sensor	PS7
Deck paper level sensor	PS8
Compartment open sensor	PS9
Compartment open detecting switch	SW1
Deck lifter lower limit detecting switch	SW2
Compartment open switch	SW100
Deck main motor	M1
Deck lifter motor	M2
Deck feeding clutch	CL1
Deck pickup clutch	CL2
Deck pickup roller releasing solenoid	SL1
Compartment open solenoid	SL2
Deck heater (option for 200/230V model)	H1
Deck drive PCB	PCB1
Open switch PCB	PCB2

T06-610-01

6.11 Variable Resistors (VR), Light-Emitting Diodes (LED), and Check Pins by PCB

Of the variable VRs, LEDs, and switches used in the machine, those needed when servicing in the field are discussed.



1. Some LEDs emit dim light even when OFF because of leakage current; this is a normal condition, and must be kept in mind.
2. VRs that may be used in the field



VRs that must not be used in the field



Do not touch the VRs and check pins not discussed herein. They are exclusively for use at the factory, and require special tools and high precision.

6.11.1 Main Controller PCB

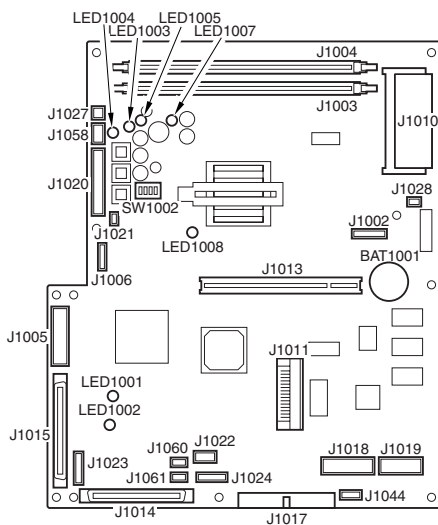

F06-611-01

6.11.2 Reader Controller PCB

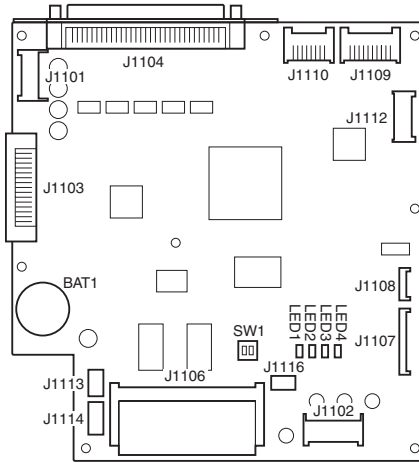

F06-611-02

6.11.3 DC controller PCB

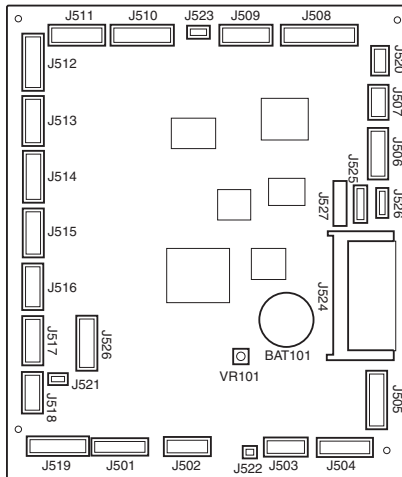

F06-611-03

6.11.4 HV-DC PCB

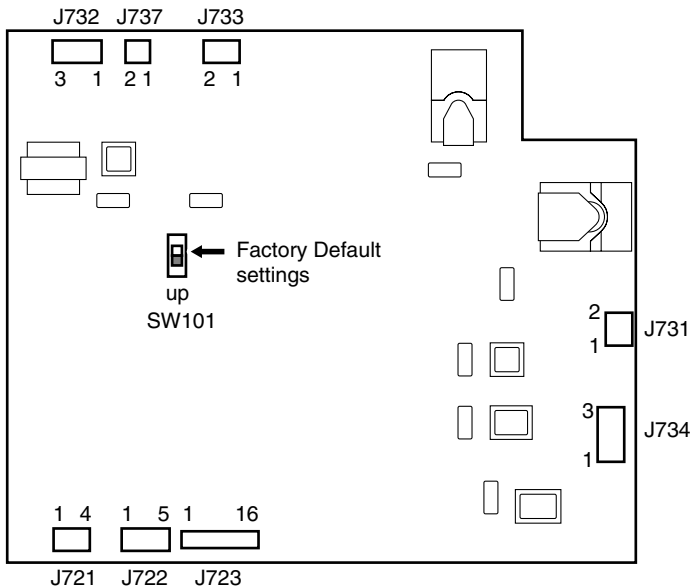

F06-611-04



Normally, keep the slide switch (SW101) in UP position. Keep this in mind when replacing the PCB.

7 Upgrading

7.1 Outline

The machine is upgraded either by downloading data from a PC or by replacing its DIMM/ROM.

The following five items are upgraded by downloading from a PC:

- BOOT ROM (machine J1009 DIMM ROM)
- HD Format (machine HDD; formatting)
- Language (machine HDD)
- RUI (machine HDD)
- System (machine HDD)

For instructions on upgrading by means of replacing the DIMM/ROM, see 7.6 “Upgrading by Replacing the DIMM/ROM.”

7.1.1 Download Mode

The machine provides two types of download modes; although any of the two may be used to download all files, select with care if you want to format the hard disk (select the HD Format), as a specific partition must be selected.

You can use any of the two when using a parallel cable; however, the use of a network cable will require you to start up the machine’s network environment, necessitating the use of downloading in service mode.

- Downloading in Download Mode

To start download mode,

- 1) While holding down ‘2’ and ‘8’ on the keypad at the same time, turn on the power switch.
- 2) Hold down ‘2’ and ‘8’ on the keypad until the bottom of the touch panel indicates the message “Download Mode.”

```
Partition Available for Formatting the Hard Disk
/BOOTDEV
ALL
```

- **Downloading in Service Mode**

To start download mode,

- 1) Start service mode.
- 2) Make the following selection: COPIER>FUNCTION>SYSTEM>DOWNLOAD. Then, press 'OK' so that the machine will be in download standby mode (message "STANDBY").

Partition Available for Formatting the Hard Disk

/PDLDEV

/FSTDEV

/DOSDEV



If you use the Service Support Tool while the machine is not in download mode, the machine will treat data from the interface as a local print job and, accordingly, will increment the job count.

When you use the Service Support Tool, be sure to switch the machine to download mode in advance by following the instructions on the screen.

7.1.2 Making Pre-Checks

Prepare the following:

- PC to which the Service Support Tool (version 1.28 or later) has been installed
- System CD
- Connection cable

The type of cable depends on how the machine is to be connected to the PC.

- In the case of a bi-Centronics interface, obtain a parallel cable (indicating IEEE 1284Std-compliant).
- Using a Network Cable

Connect the machine with the PC using a cross Ethernet cable or a straight Ethernet cable and a HUB.

The following shows how a cross Ethernet cable may be used.

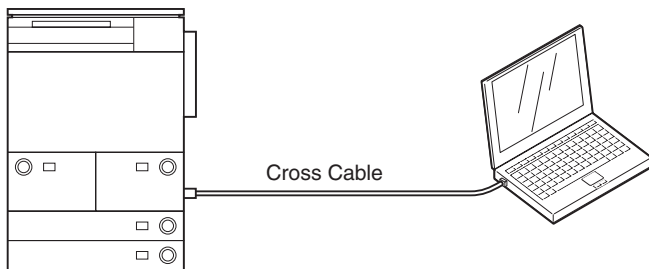

F06-701-01



If you are using a straight Ethernet cable and a HUB, you are encouraged to connect the machine with the PC on a one-on-one basis, outside the user's network environment.

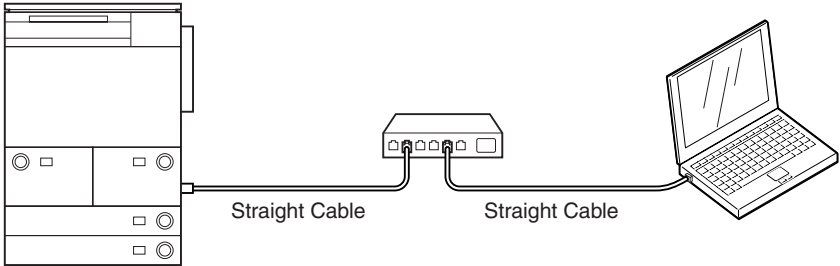

F06-701-02



Differences in Connection Between Bi-Centronics Cable and Network Cable

Each has its own advantages and disadvantages; select one to suit specific needs:

Connection with a Bi-Centronics Cable (using a parallel cable)

Advantages:

- You can use the Service Support Tool without considering the environment of the user's network.
- If the system is not installed on the hard disk, the system may be installed or the hard disk may be formatted using download mode.

Disadvantages:

- The specifications of the PC used or the chip set may not allow the use of high-speed mode, i.e., it has a low level of compatibility.
- The PC must have a parallel interface.
- You can not use high-speed mode on Windows NT or Windows 2000.

Connection with a Network Cable

Advantages:

- It is relatively high speed.
- It is less dependent on the PC to be used.
- The use of a cross cable enables direct connection.

Disadvantages:

- You must change the network settings of the machine or the PC to suit the user's network environment. More importantly, you must change the machine back to its initial settings after the task.
 - You must have a good knowledge of networking.
 - The system must start up normally and the network settings must be correct.
-



Points to Note When Using a Bi-Centronics Interface and a Network

The Service Support Tool allows you to select one of two interfaces to suit specific needs. If both are in use, you must turn the machine off and then on first before making a switch-over (i.e., from Bi-Centronics to Network or vice versa), thereby preventing errors in the event of simultaneous writing operations.

7.2 Data Control

You must install the files to use (System, RUI, HD Format , BOOT, Language) before executing downloading.

- 1) Start up the Service Support Tool.
- 2) Under 'Controlling Data', select 'To Next'.

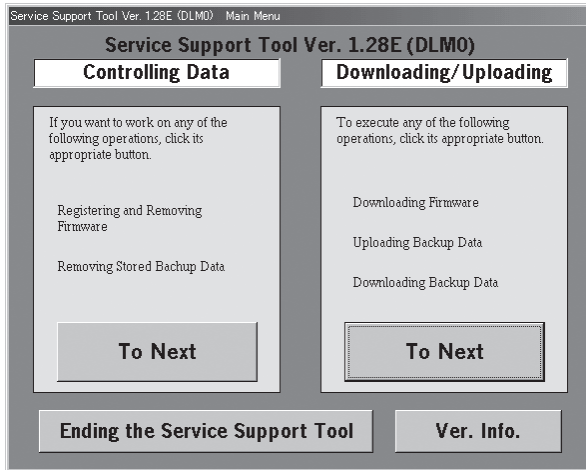

F06-702-01

3) From the Control Work screen of the firmware, select 'Registering Firmware'.

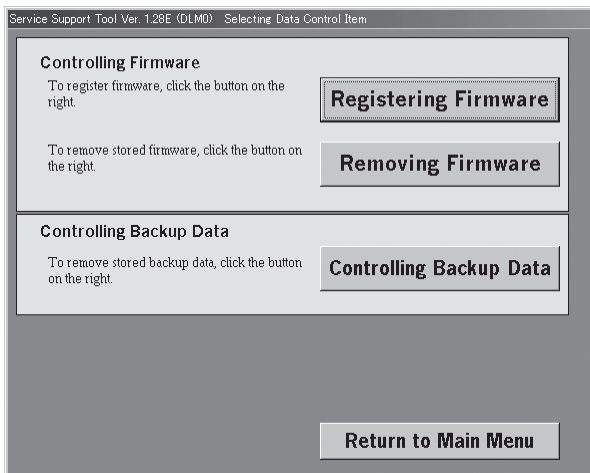

F06-702-02

4) From the following screen, select 'Register from selected folder'.

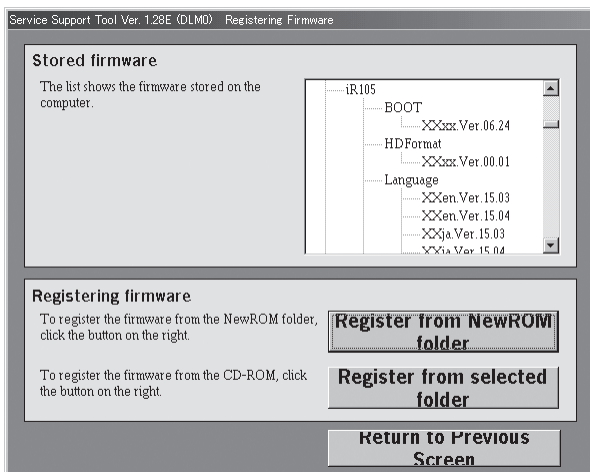

F06-702-03

- 5) Select the drive to which you have inserted the System CD.
- 6) Select the folder of the suitable version, and click 'Register'.

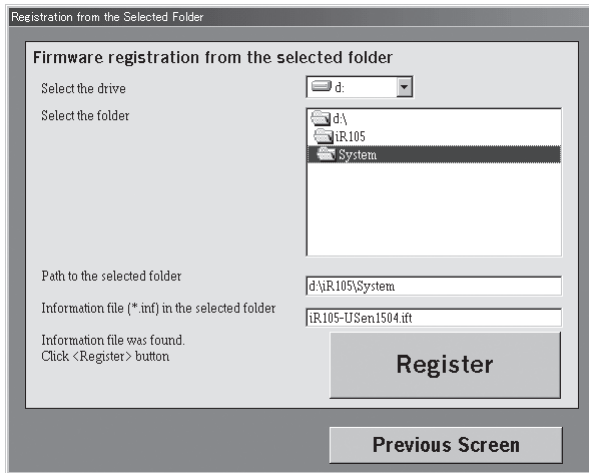

F06-702-04

7.3 Downloading the System Software, RUI, and Language Module

7.3.1 Making Connections

The discussions that follow are based on the use of a parallel cable:

- Check to make sure that the Processing/Data lamp is OFF.
 - 1) Turn off the machine's main power switch, and disconnect the power plug and the network cable.
 - 2) Using a parallel cable, connect the PC to the parallel connector on the left side of the controller.
- At this time, the PC must remain OFF.
- Connect the 25-pin connector of the cable to the PC and the 36-pin connector to the machine.
 - 3) Turn on the power switch of the PC, and start up the Service Support Tool.
 - 4) Connect the machine's power plug to the power outlet, and turn on the main power switch.

7.3.2 Downloading

- 1) Under 'Downloading/Uploading', select 'To Next'.

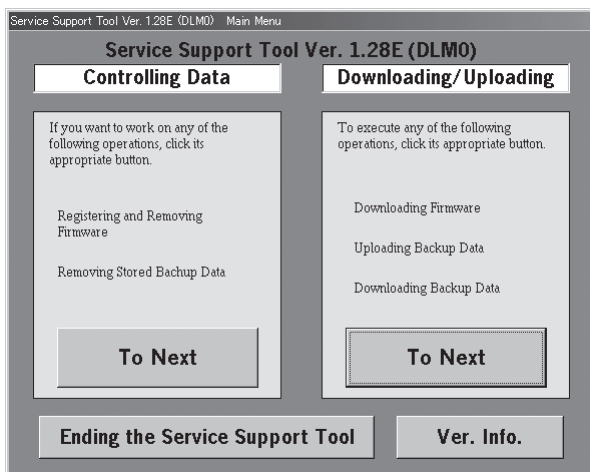

F06-703-01

- 2) Start the machine's service mode, and make the following selections: COPIER>FUNCTION>SYSTEM>DOWNLOAD. Then, press 'OK' so that the machine will be in download standby mode (notation "STNDBY").
- 3) Select SYSTEM, RUI, or Language, and select the interface (either Bi-Centronics or Network). The discussions that follow assume that you have selected bi-Centronics.

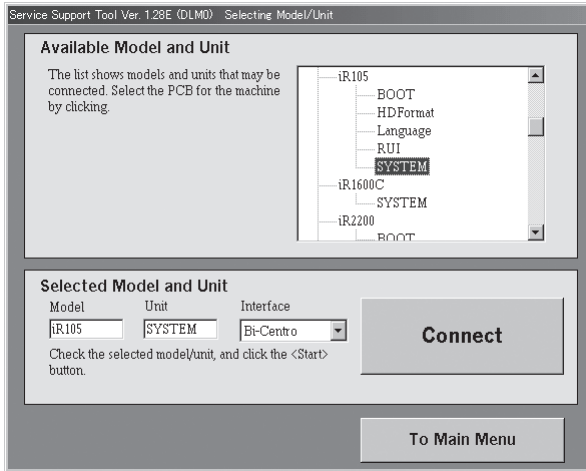

F06-703-02



Memo

About the Language Module (Language)

A language module is a unit containing the language data needed to indicate messages in the control panel, each module designed for a specific language. Install only those language modules you need, thus saving time spent for downloading. You can switch among installed language modules in user mode: common settings> display language. At time of shipment, five modules (languages) are installed. The modules will be lost once you format the hard disk, requiring you to install them once again to suit the needs of the user. To check the version of the modules, make the following selections: COPIER>DISPLAY>VERSION>LANG-XX. Check to make sure that the version of each language module matches the version of the installed system software; otherwise, use the language module built into the system software to start up. The built-in module is not part of the modules that may be selected as the display language; for this reason, you will not be able to make use of the language switch unless you have installed modules independently of the system software. If you replace an existing language module with a module of an inappropriate version, 'E744-0001' will be indicated when the machine is started up for the first time; to reset the error, install a module of the correct version.

- 4) If the notation in the upper right of the screen is 'High-Speed', go to step 6); if 'Low-Speed', go to step 5).

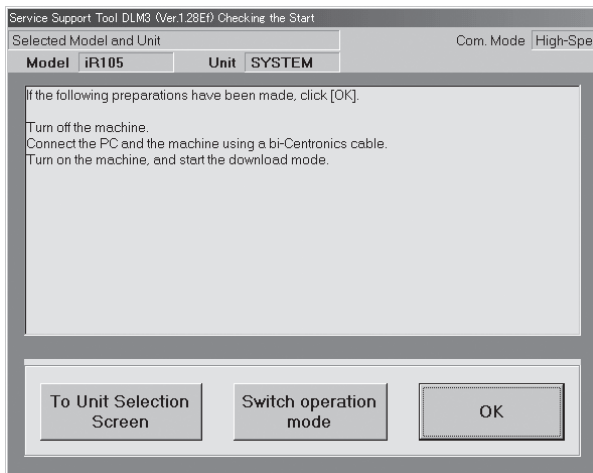

F06-703-03

- 5) Click 'Switch operation mode' to bring up the Centronics Communication Mode Change screen. Select 'High-Speed', and press 'OK' to move to step 6).



Memo

High-speed mode is not supported on Windows NT and Windows 2000.

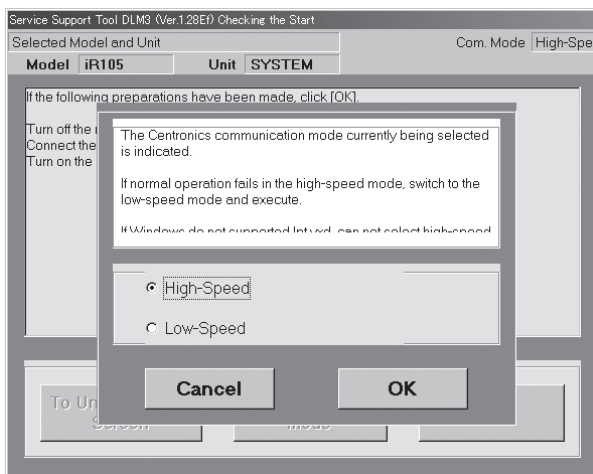

F06-703-04

- 6) Click 'OK' to start connection.

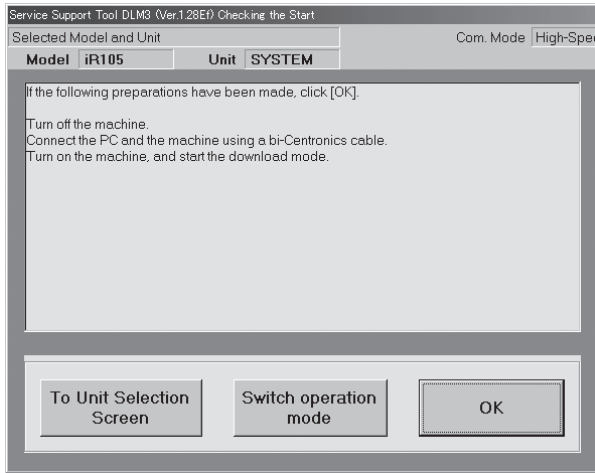

F06-703-05

- 7) When connection is done, the following screen will appear. Click 'OK'.

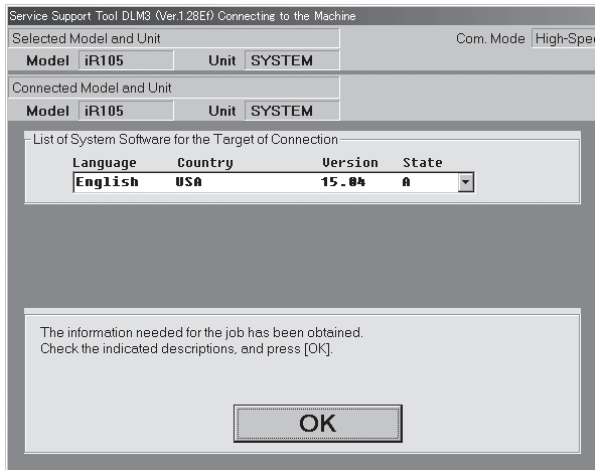

F06-703-06

8) Select 'System Software Download' of the Service Support Tool screen.

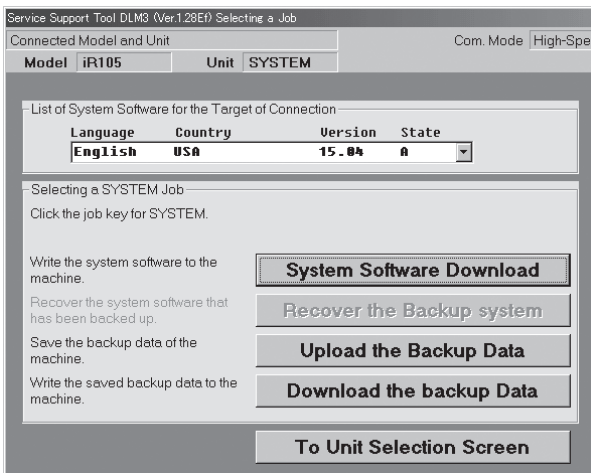

F06-703-07

9) Select the files suited to the language and the country in question from the 'list of software' on the Service Support Tool screen, and click 'Start'.

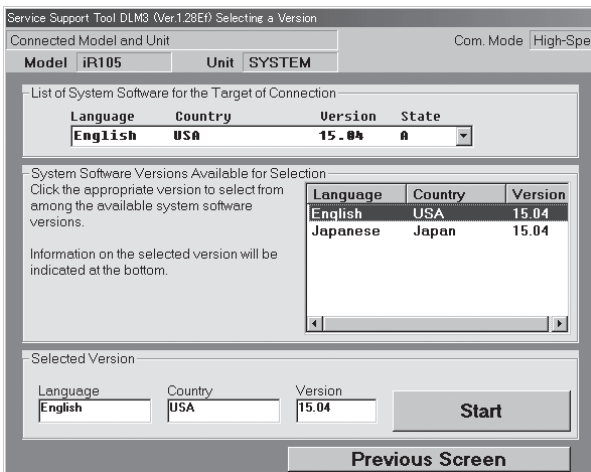

F06-703-08

- 10) The following screen will appear to indicate the types of software that will be downloaded: “Function: COPY/PRINTER” “NetWare: YES/NO.” If the indications are correct, click ‘Start’.

Service Support Tool DLM3 (Ver.1.28E) Selecting a Version

Connected Model and Unit Com. Mode High-Speed

Model **iR105** Unit **SYSTEM**

List of System Software for the Target of Connection

Language	Country	Version	State
English	USA	15.04	A

Connected target has functions below.

Function: COPY
NetWare: NO

Select Again Start

Selected Version

Language Country Version Start

Previous Screen

F06-703-09



Installing System Software with Different Functions

Normally, you cannot upgrade existing system software by means of downloading unless the old and new systems have the same functions; an attempt to do so will result in an error. If the user obtains the official Upgrading kit and follow the appropriate procedure, however, such upgrading is possible; for details, see the Installation Procedure that comes with the Upgrading kit.

- 11) Check the progress bar, which indicates the progress of downloading.
- 12) When downloading ends, turn off the PC by making the following selections: OK>To Unit Selection Screen>OK>To Main Menu>Ending the Service Support Tool>End.

7.3.3 After Downloading

- 1) Turn off the machine's main power switch, and disconnect its power plug.
- 2) Turn off the PC.
- 3) Disconnect the parallel cable from the PC and the machine.
- 4) If a network cable is connected, connect it to its correct location, and turn on the machine's main power switch.
- 5) When the machine has started up, start service mode to check the system version for the HDD: COPIER>DISPLAY>VERSION>MN-CONT.

7.4 Upgrading the BOOT ROM

7.4.1 Making Preparations

When you upgrade the machine's BOOT ROM, you will directly replace the contents of the ROM DIMM. Take full care.

- 1) Check to see that the machine's Data lamp is OFF.
- 2) Turn off the machine's main power switch, and disconnect the power plug and the network cable.



Limits on Preparing the BOOT ROM

You will not be able to prepare the BOOT ROM unless the following conditions are met:

- The model of the machine is the same; e.g., you cannot use the iR8500 BOOT ROM data to upgrade an iR5000.
- The parameter "function" (COPY or PRINTER) must match when downloading the system software; i.e., you cannot use the iR8500N (PS/PCL model) BOOT ROM data to upgrade an iR8500. (The same is true of from PS/PCL model to COPY.)

Any attempt made in disregard of the above will cause a mismatch error when the machine runs a check before writing.

7.4.2 Connection

The following discussions assume the use of a network cable (cross cable).

Making Preparations

If you want to download firmware to the machine using a network, you need to set up the PC and the machine's network environment.

Use TCP/IP as the communication protocol for downloading from a network using the Service Support Tool. Connect the PC to the machine by way of the network, and check to make sure that all are ready for communication by sending a PING command from the PC or the machine.

- 1) Connect the machine's network connector (RJ-45) and the network connector of the PC using a network cable (cross cable).
- 2) Turn on the PC, and start up the Service Support Tool.
- 3) Connect the machine's power plug to the power outlet, and start service mode; make the following selections: COPIER>FUNCTION>SYSTEM>DOWNLOAD. Then, click 'OK' so that the machine will be in download standby mode (notation "STNDBY").

7.4.3 Preparing BOOT ROM

The discussions that follow assume upgrading an iR8500 (COPY model).

- 1) User 'Downloading/Uploading', select 'To Next'.

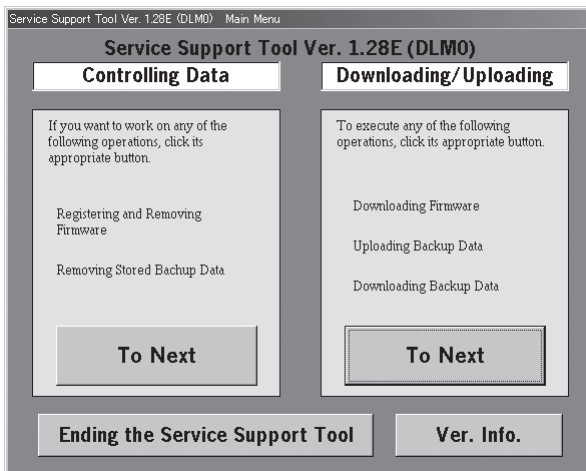

F06-704-01

- 2) Select the correct BOOT, and select an interface (bi-Centronics or Network). (The example selects iR8500 for BOOT, and Network is selected for Interface.)

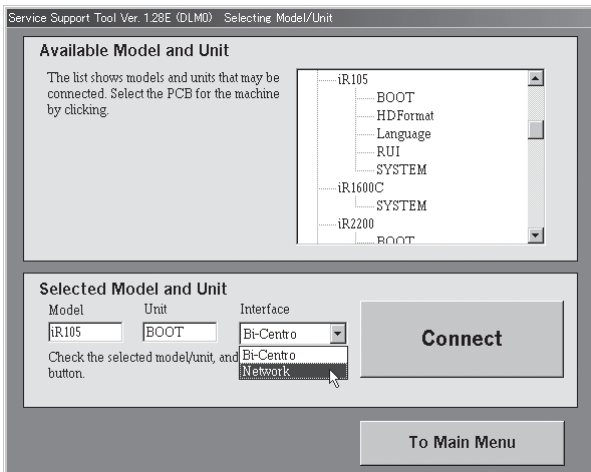

F06-704-02

- 3) To enter the IP address or the host name of the machine to connect, click 'Set host name'.

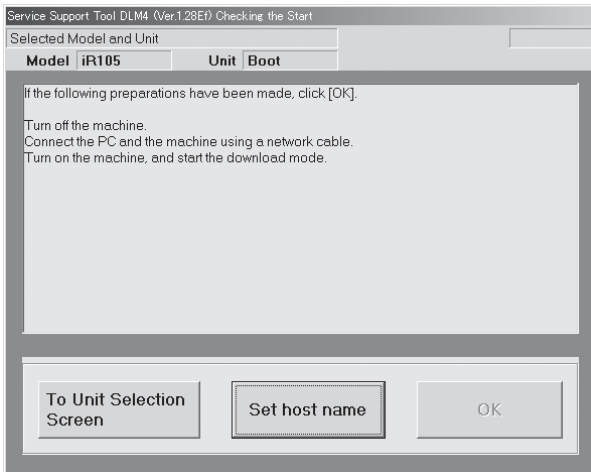

F06-704-03

- 4) Enter the IP address or the host name (here, 172.16.1.1), and click 'Save'. Then, click 'OK'.

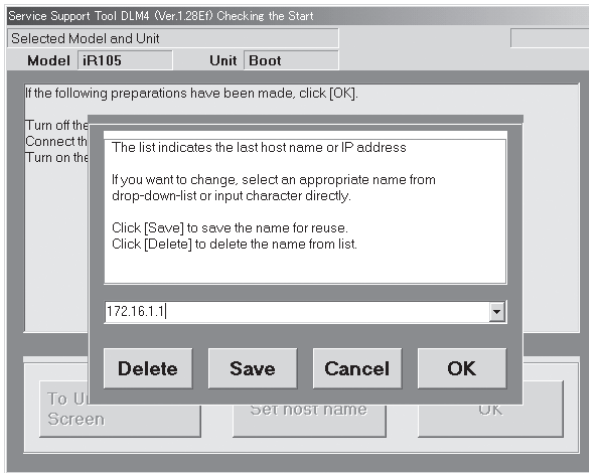

F06-704-04

- 5) Check to see that the notation in the upper right indicates the IP address or the host name of the machine to connect; then, click 'OK' to start connection.

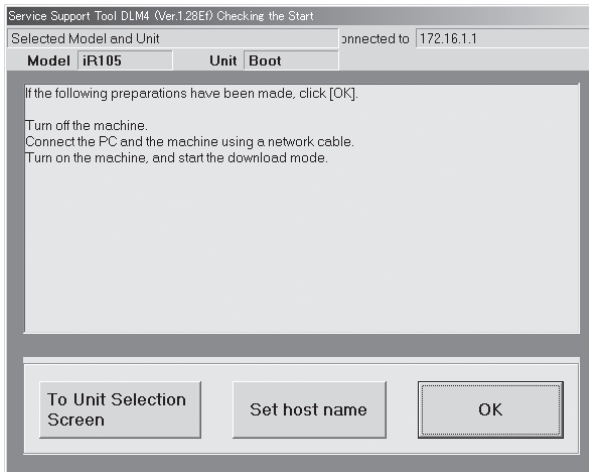

F06-704-05

- 6) When connection is done, the following screen appears. Click 'OK'.

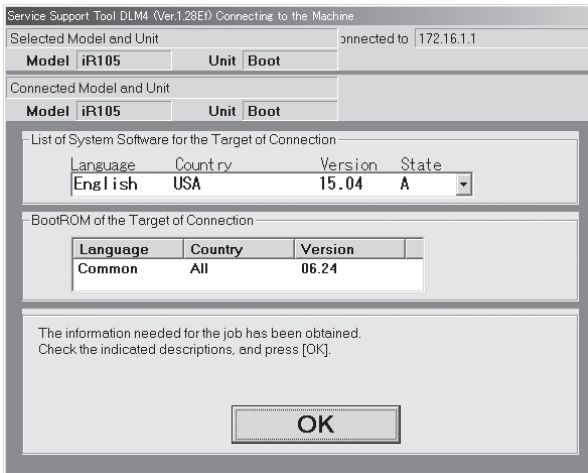

F06-704-06

- 7) Select 'BOOT ROM Download' on the Service Support Tool screen.

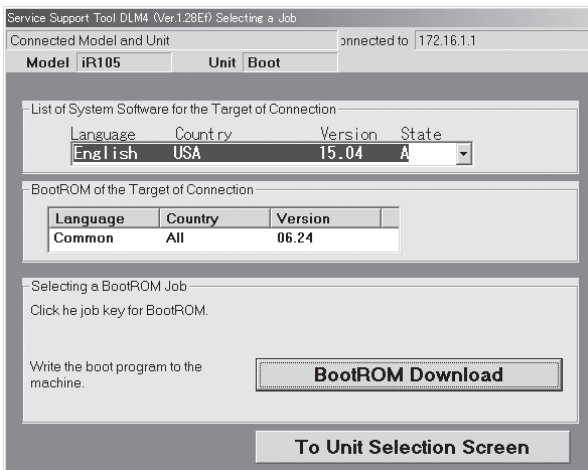

F06-704-07

- 8) Select the files for the version in question of the Service Support Tool from ‘list of software’; then, click ‘Start’ to start downloading.

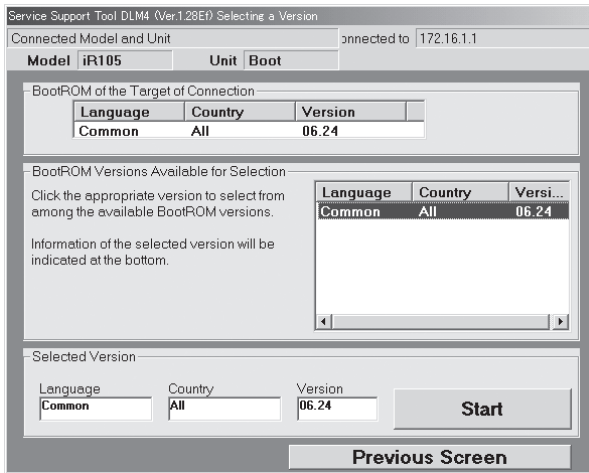

F06-704-08

- 9) See the progress bar, which indicates the progress of downloading.



Take full care so that the machine and the PC will not be turned off while downloading is taking place. Otherwise, they may fail to start up.

- 10) When downloading ends, turn off the PC by making the following selections: OK>To Unit Selection Screen>OK>To Main Menu>Ending the Service Support Tool>End.

7.4.4 After Downloading

- 1) Turn off the machine's main power switch, and disconnect the power plug.
- 2) Turn off the PC.
- 3) Disconnect the network cable (cross cable) and the PC from the machine.
- 4) If a network cable is connected, connect it to the correct location, and turn on the machine's main power switch.
- 5) When the machine has started up, start service mode, and check the version of the BOOT ROM: COPIER>DISPLAY>VERSION>BOOT-ROM.

7.5 Formatting the HDD

If you have replaced the HDD, you must format it and then download the system software, RUI, and language.

7.5.1 Making Connections

The discussions that follow assume the use of a parallel cable:

- 1) Using a parallel cable, connect the PC to the parallel connector on the left side of the controller.
 - At this time, the PC must remain OFF.
 - Connect the 25-pin connector of the bi-Centronics cable to the PC and the 36-pin connector to the machine.
- 2) Turn on the PC, and start up the Service Support Tool.
- 3) Connect the machine's power plug to the power outlet; while holding down '2' and '8' of the keypad at the same time, turn on the main power switch.

7.5.2 Starting Formatting

- 1) Under 'Downloading/Uploading', select 'To Next'.

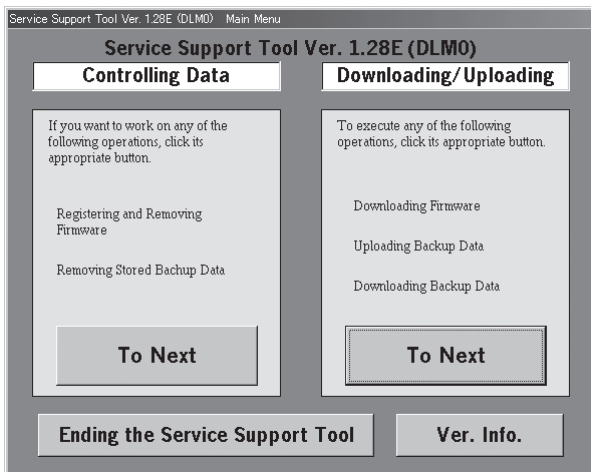

F06-705-01

- 2) Select 'HD Format', and select 'Connect'.

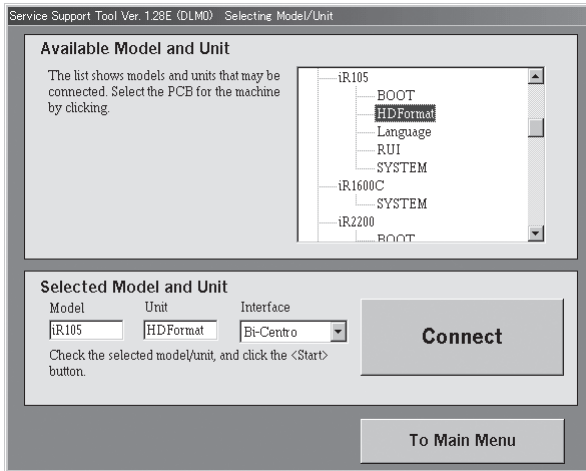

F06-705-02

- 3) At this time, if the notation in the upper right of the screen is 'High-Speed', go to step 5); if 'Low-Speed', go to step 4).

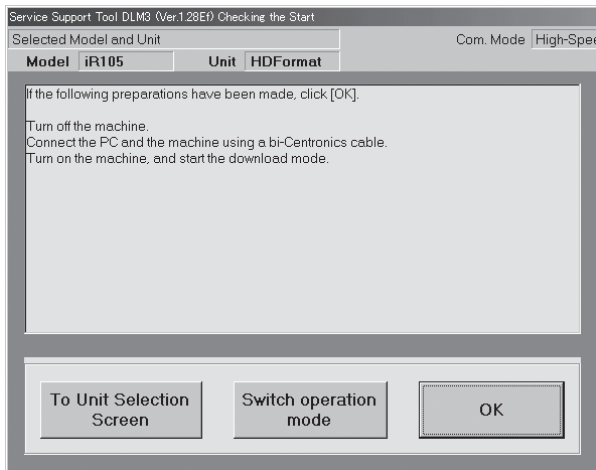

F06-705-03

- 4) Click 'change operation mode' so that the Centronics Communication Mode change screen will appear. Select 'high-speed', and click 'OK'; then, go to step 6).

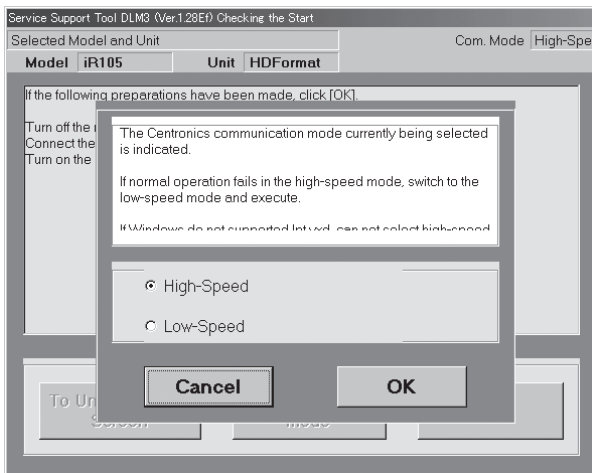

F06-705-04

- 5) Click 'OK' to start connection.

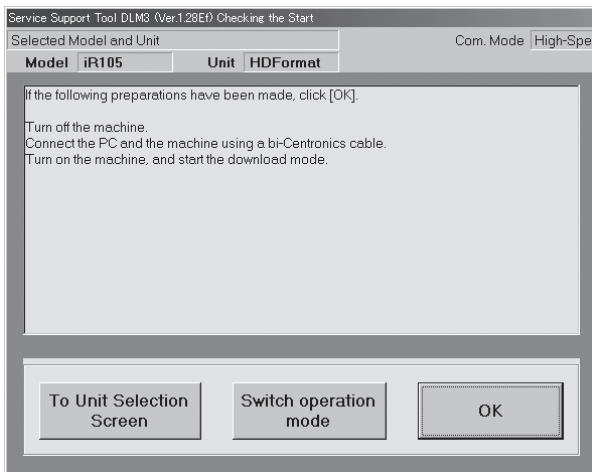

F06-705-05

- 6) When connection is done, the following screen will appear. Select 'OK'.

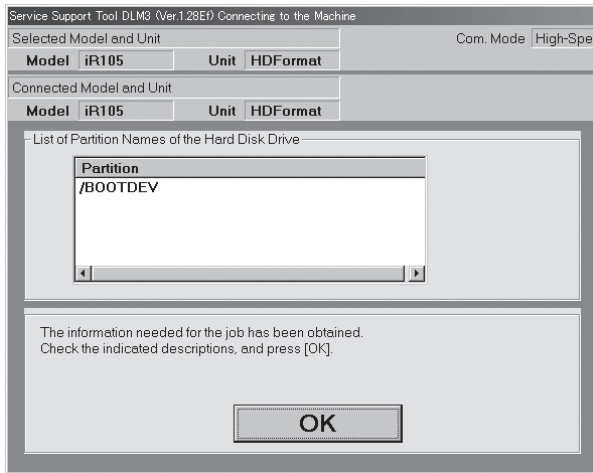

F06-705-06

- 7) When the Check screen appears, select 'Format'.

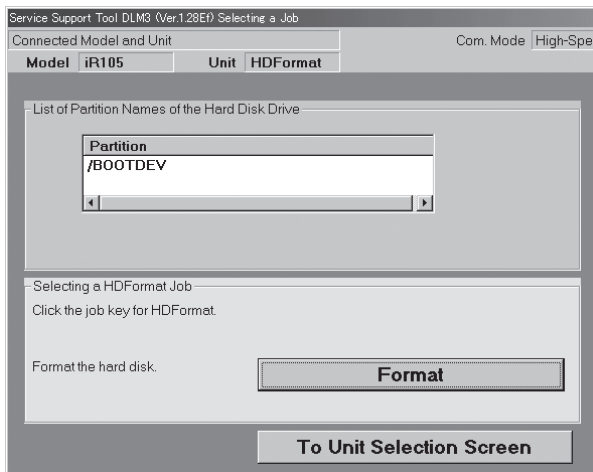

F06-705-07

8) When the Start Check screen appears, select 'Start' to format all partitions.

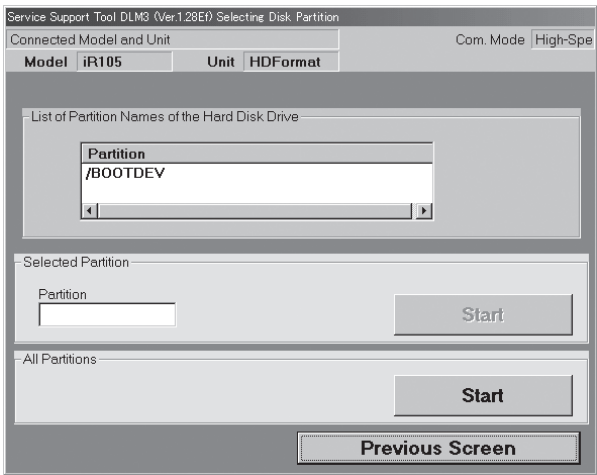

F06-705-08

9) When the Start Check screen appears once again, select 'Start'.

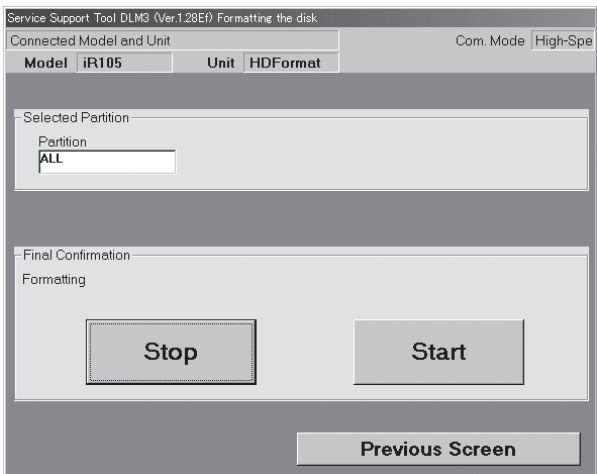

F06-705-09

10) When formatting is done, the message “Format Finished” appears. Click ‘OK’.

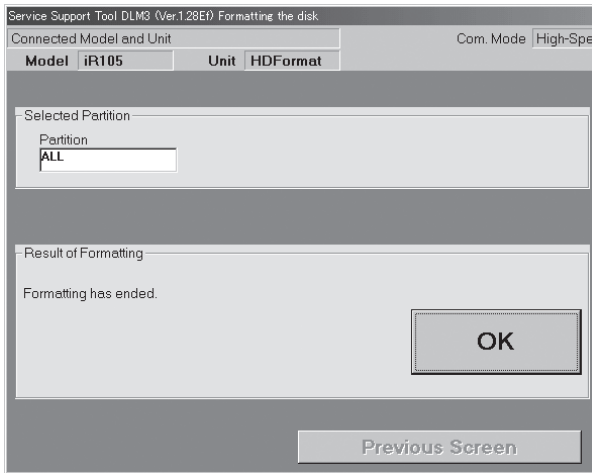

F06-705-10

11) To continue downloading system, select ‘To Unit Selection Screen’, and click ‘OK’. Then, start downloading system.

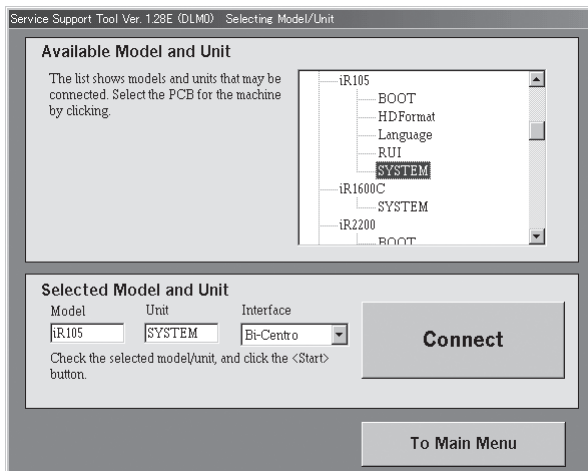

F06-705-11

12) When the system downloading ends, install the RUI and the Language module in the same way.

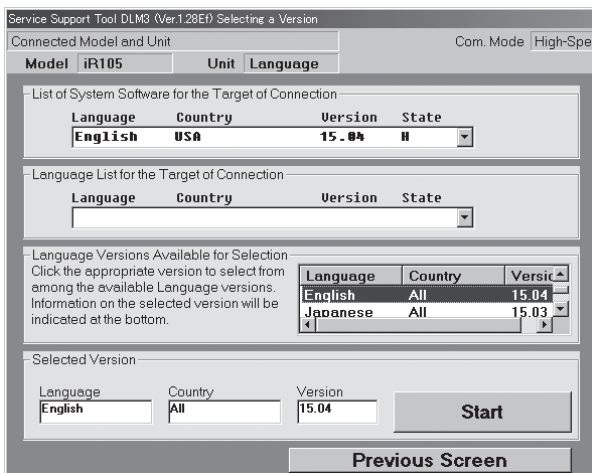

F06-705-12

7.5.3 Points to Note When Formatting the Hard Disk



1. If you have formatted the hard disk, you must also download the system software at the same time. Otherwise, 'E602-0002' will be indicated when you turn on the power.
If the system software is yet to be installed to the hard disk, the hard disk may still be formatted or the system software may be downloaded in download mode.
Connecting to the Network (using network cable)
2. If you want to install the Language module after installing the system software, you must be sure that its version is compatible with the version of the system software. If you install a Language module not compatible with the system software in question and, in addition, if that language is selected in user mode, 'E744-0001' will be indicated.
3. If you installed the system software after formatting the hard disk, you may notice a faulty image on the control panel display. This is a normal condition, and will disappear when you turn off and then on the machine twice.

7.6 Upgrading by Replacing the DIMM/ROM

The following items may be upgraded by replacing the DIMM/ROM; the DIMM/ROM will be provided as a service part on its own:

- Copier

Reader controller PCB: by replacement of flash ROM DIMM [1]; J1106

DC controller PCB: by replacement of flash ROM DIMM [2]; J521

Main controller PCB: by replacement of BOOT ROM [7]; J1010, see MEMO

DADF-J1

ADF controller PCB: by replacement of ROM [4]; IC1 (DIP type)

Finisher-K1N/K2N

by replacement of ROM [5]; IC110 (DIP type)

Saddle Finisher-K3N/K4N

Finisher controller PCB: by replacement of ROM [5]; IC110 (DIP type)

Saddle stitcher controller PCB: by replacement of ROM [6]; Q2 (DIP type)



In addition to the program for the master CPU, the ROM of the finisher controller PCB contains programs for the slave CPU, requiring you to upgrade the slave CPU software whenever you have replaced the ROM. For details, see the Service Manual of the finisher.

The BOOT ROM [7] on the main controller PCB may be upgraded using a PC. For details, see the descriptions under 7.4 “Upgrading the BOOT ROM.”

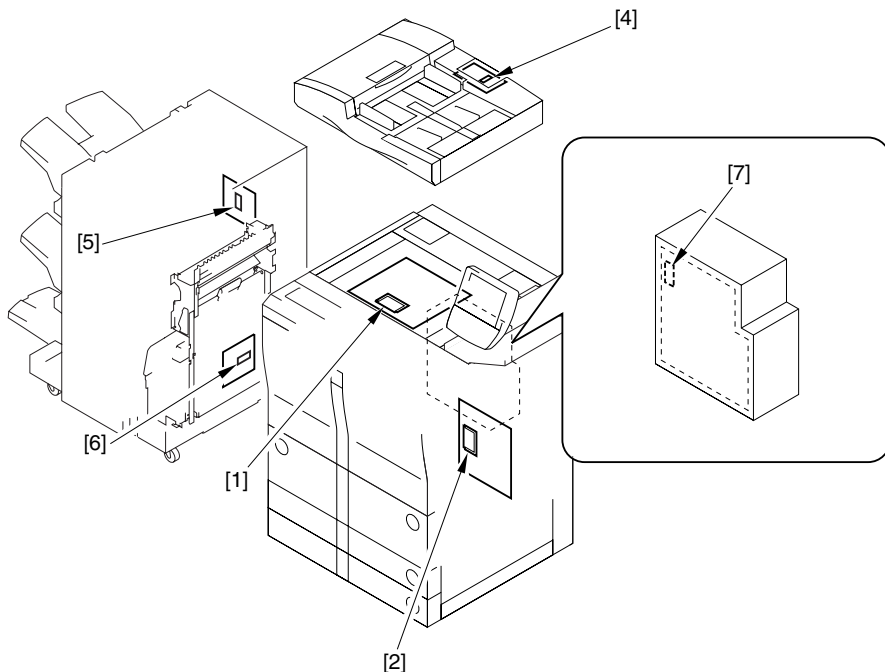

F06-706-01

8 Backing Up Data

8.1 Outline

Using the Service Support Tool, you can back up the data of the SRAM mounted to the main controller PCB.

The SRAM contains the following items of data:

- Service mode settings
- User mode settings
- Various MACHINE DATA

Once you have backed up the data, you may write it to the main controller PCB after replacing the PCB; or, you can simplify the work involved in entering service mode or user mode settings.

It is recommended to back up the data whenever possible using the Service Support Tool when you have updated the service mode settings or the user mode settings.

8.2 Backing Up Data

8.2.1 Making Preparations

- Install the system software to the Service Support Tool, making sure that its version is the same as that of the machine in question.
- Check to make sure that the machine's Data lamp is OFF.
- Turn off the machine's main power switch, and disconnect the power plug; as necessary, disconnect the network cable.

8.2.2 Making Connections

The discussions that follow assume the use of a parallel cable:

- 1) Using a parallel cable, connect the PC to the parallel connector on the right side of the controller.
 - At this time, the PC must remain OFF.
 - Connect the 25-point connector of the parallel cable to the PC and the 36-pin connector to the machine.
- 2) Turn on the power switch of the PC, and start up the Service Support Tool.
- 3) Connect the machine's power plug to the power outlet, and turn on its main power switch.
- 4) Start service mode.
- 5) Make the following selections so that the machine will enter download standby mode (notation "STNDBY"): COPIER>FUNCTION>SYSTEM>DOWNLOAD.



You can select 'network' as the interface for data backup. Here, the use of a bi-Centronics cable is assumed.

8.2.3 Backing Up Data

- 1) Under 'Downloading/Uploading', select 'To Next'.

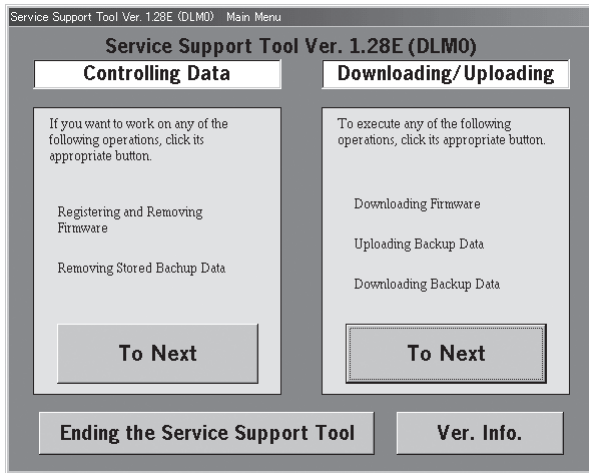

F06-802-01

- 2) Select 'SYSTEM', and select 'Connect'. The discussions that follow assume the use of a bi-Centronics cable as the interface.

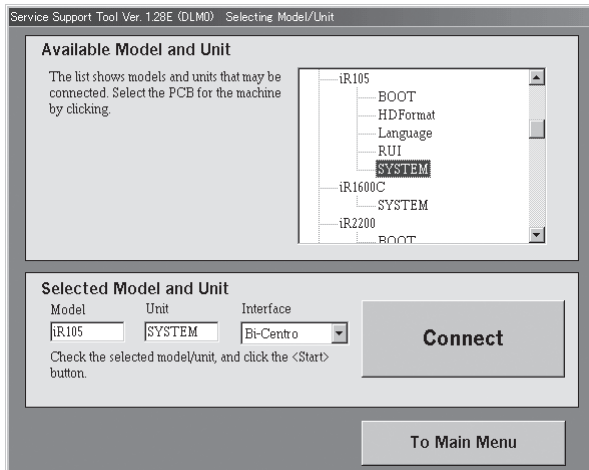

F06-802-02

- 3) At this time, if the notation in the upper right of the screen is 'High-Speed', go to step 5); if 'Low-Speed', go to step 4).

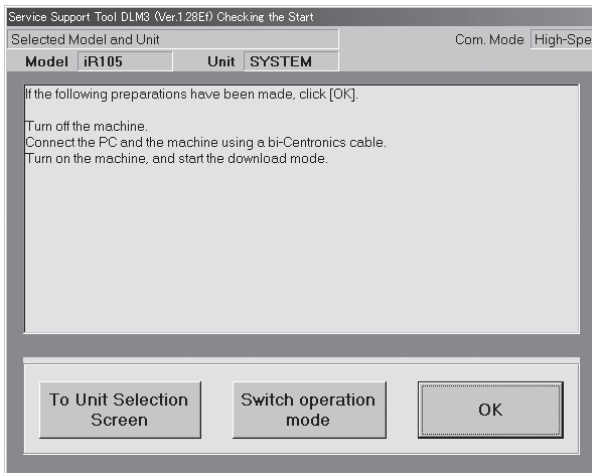

F06-802-03

- 4) Click 'Switch operation mode' to bring up the Centronics Communication Mode Change screen. Select 'High-Speed', and click 'OK' to move to step 5).

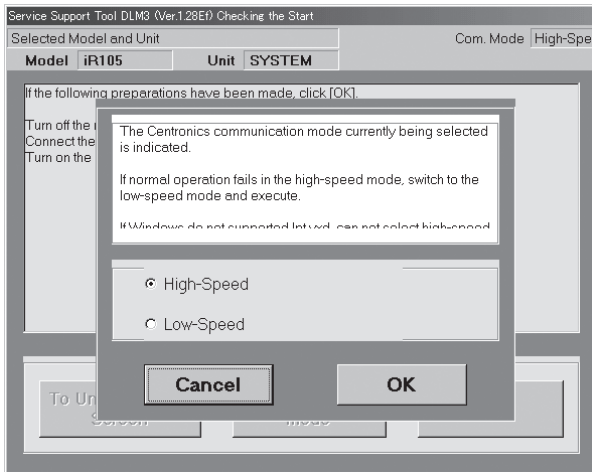

F06-802-04

- 5) Click 'OK' to start connection.

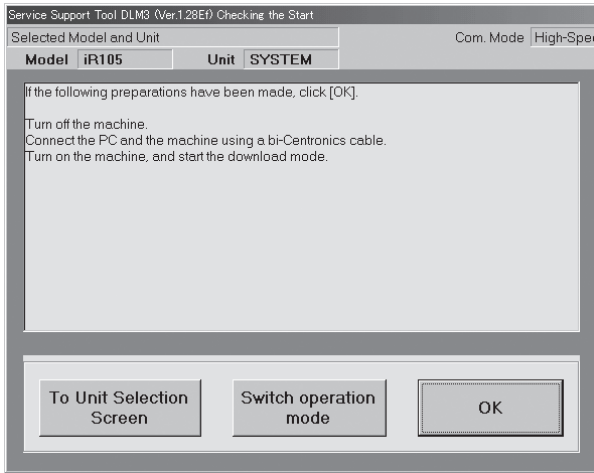

F06-802-05

- 6) When connection is done, the following screen appears. Click 'OK'.

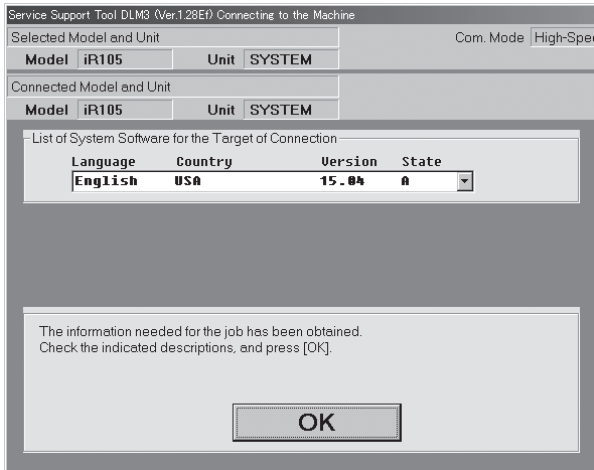

F06-802-06

7) Select 'Upload the Backup Data' on the Service Support Tool screen.

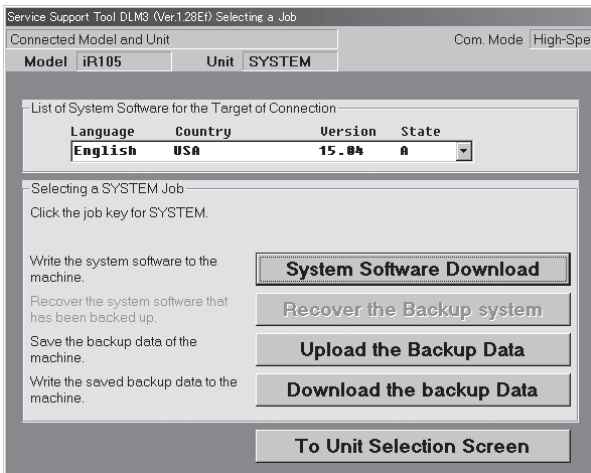

F06-802-07

8) Select 'ALL', and select 'Start Storing'.

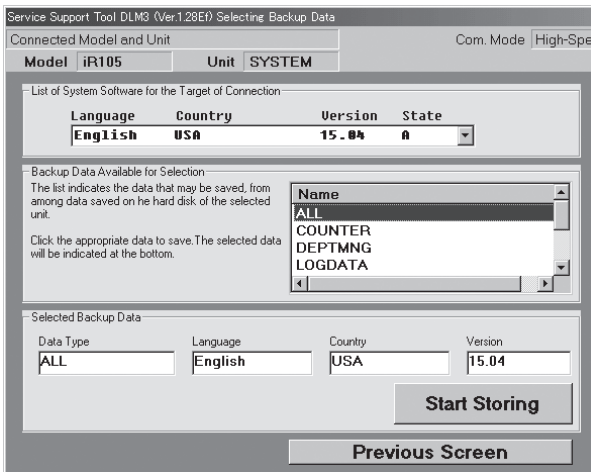

F06-802-08

- 9) See the progress bar, indicating the progress of the save operation.
- 10) Select the drive to save the data to, and enter the file name; then, select 'Save'.

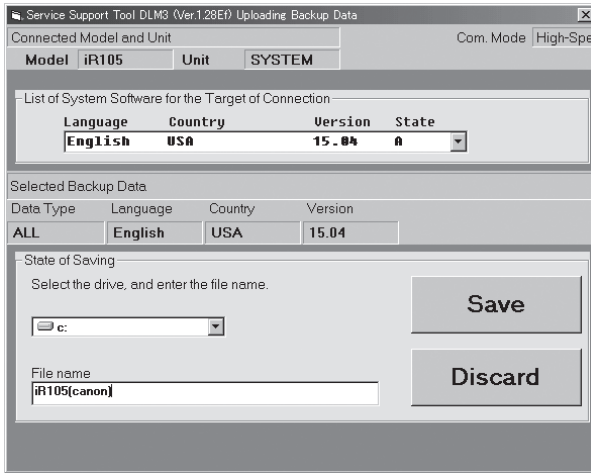

F06-802-09

- 11) When the selected file has been stored on the selected drive, the following screen will appear; make the following selections to end the Service Support Tool: OK>To Unit Selection Screen>OK>To Main Menu>Ending the Service Support Tool>End.

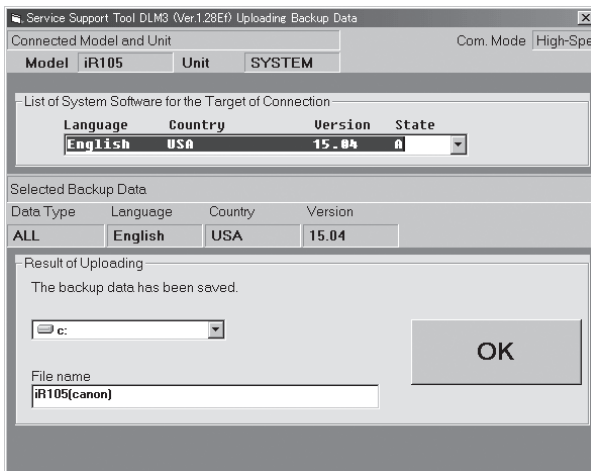

F06-802-10

8.2.4 Downloading Backup Data

1) Under 'Downloading/Uploading', select 'To Next'.

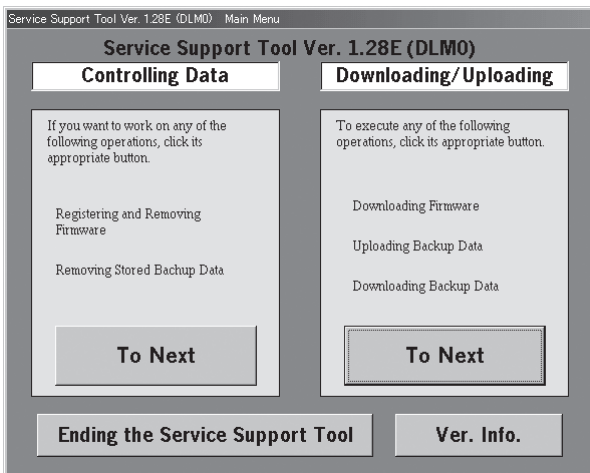

F06-802-11

2) Select 'SYSTEM', and select 'Connect'.

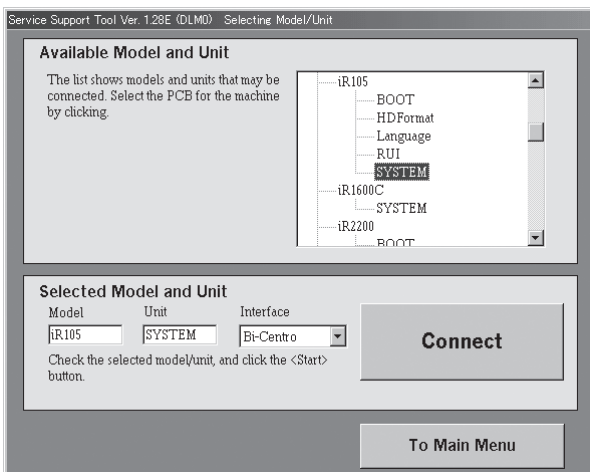

F06-802-12

- 3) Select 'OK', and start connection.

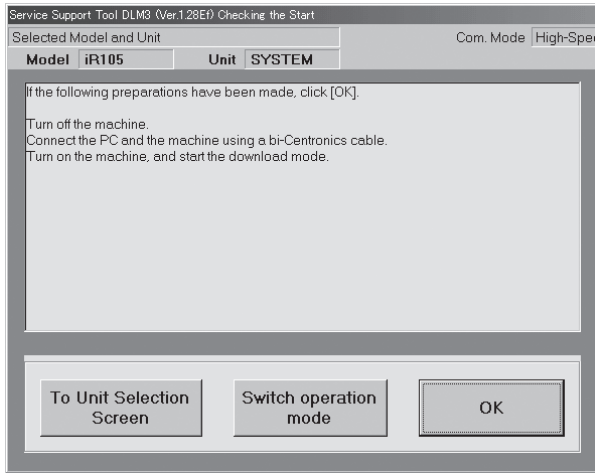

F06-802-13

- 4) When connection is done, the following screen appears. Click 'OK'.

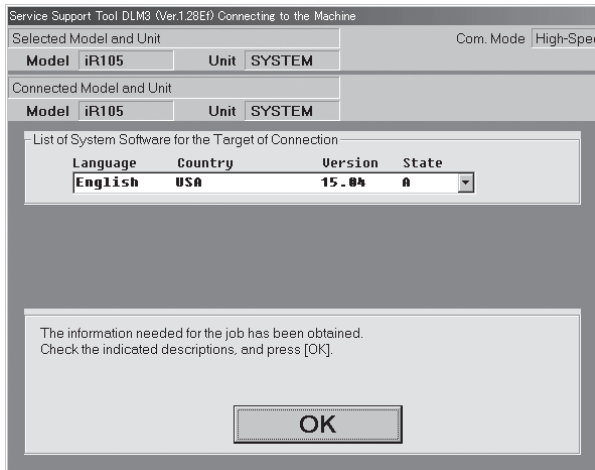

F06-802-14

5) Select 'Download the backup Data'.

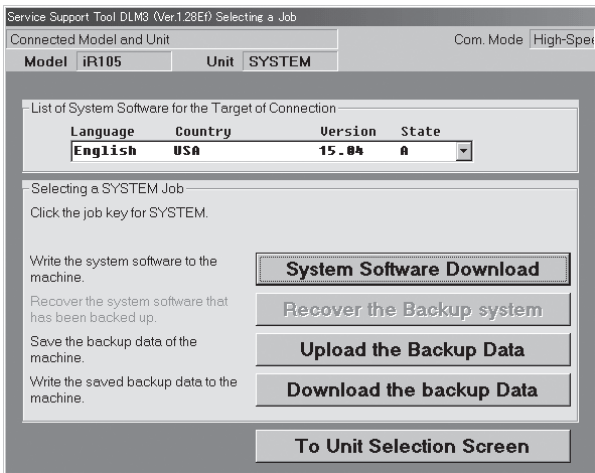

F06-802-15

6) Select the file to download, and select 'Start Writing'.

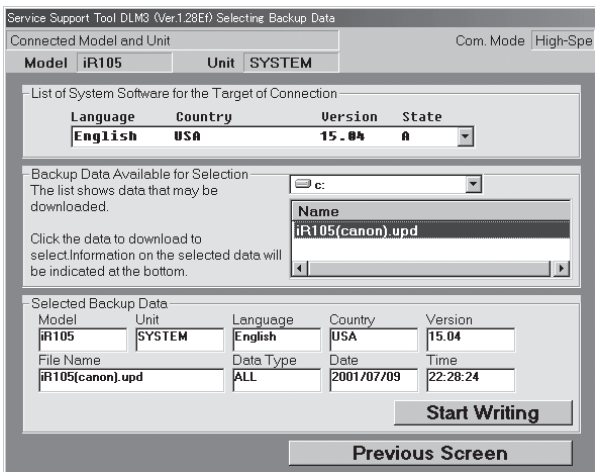

F06-802-16

- 7) See the progress bar, indicating the progress of the downloading operation. At the end, the following screen will appear. Select 'OK'.

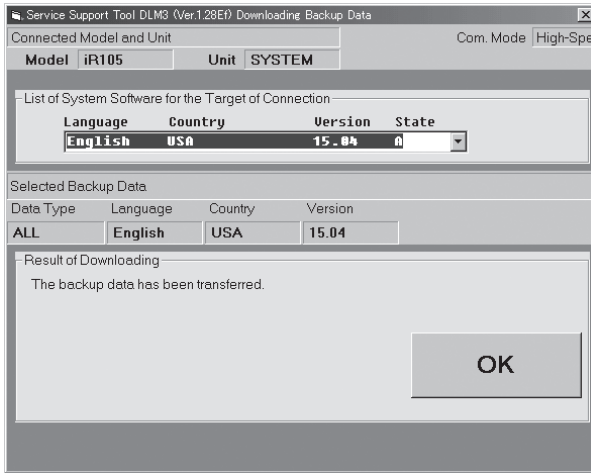

F06-802-17

- 8) Make the following selections to end the Service Support Tool: To Unit Selection Screen>OK>To Main Menu>Ending the Service Support Tool>End.

8.2.5 Managing Backup Data

You can delete backup data that has become obsolete as follows:

You need not connect a PC to the machine to do so.

- 1) Under 'Controlling Data', select 'To Next'.

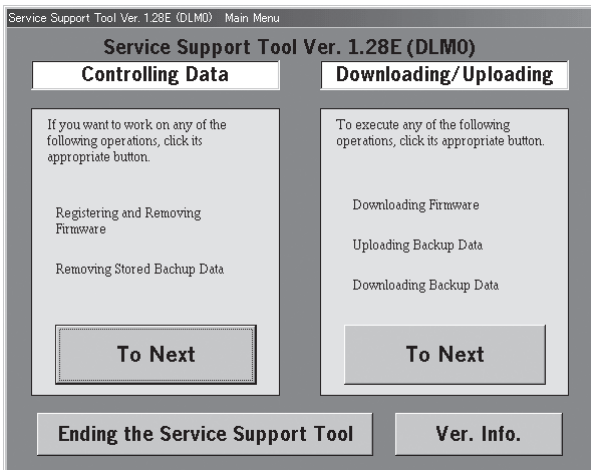

F06-802-18

- 2) Select 'Controlling Backup Data'.

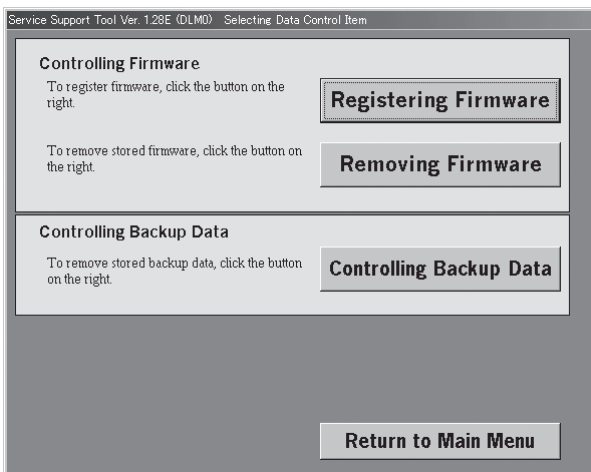

F06-802-19

- 3) Select the file to delete from the list of 'Backup Data Stored on Computer'; then select 'Remove'.

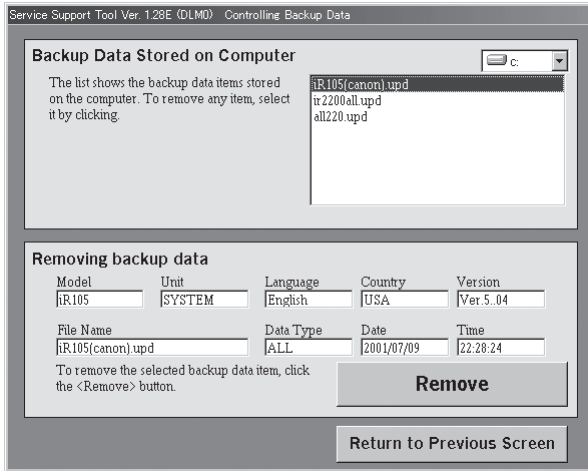

F06-802-20

- 4) When the Delete Check screen appears, check the description for the selected file, and select 'Remove'.

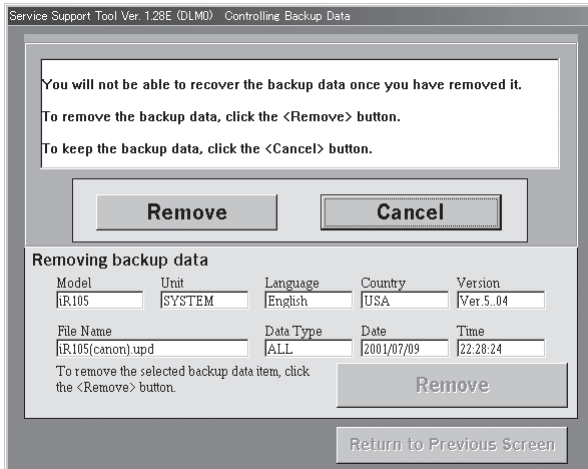

F06-802-21

- 5) When the Delete Finish screen appears, click 'OK'. Make the following selections to end the Service Support Tool: Return to Previous Screen>Return to Main Menu>Ending the Service Support Tool>End.

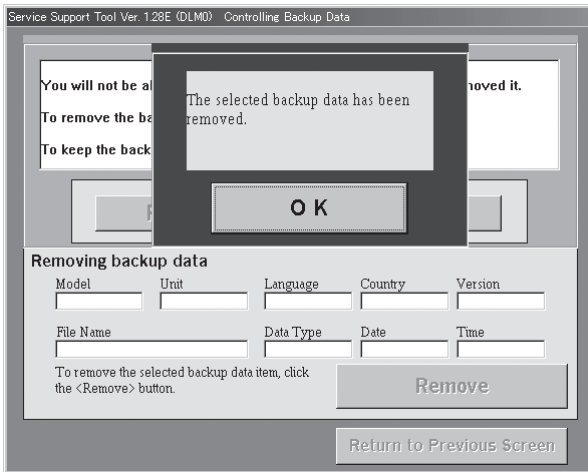

F06-802-22

APPENDIX

1 GENERAL TIMING CHART

A4, 2 Originals, Single-Sided Copy

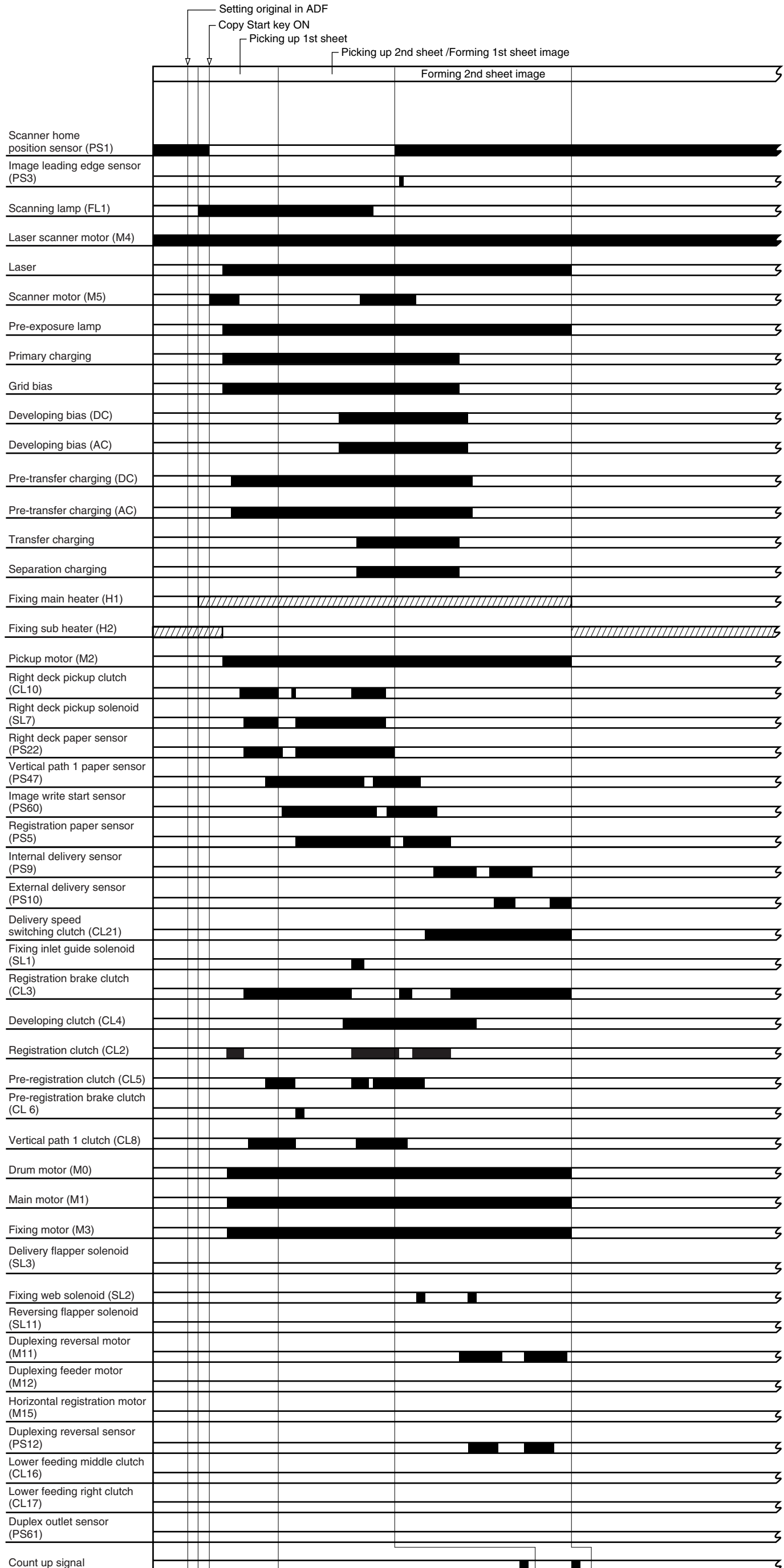

A4, 4 Originals, Double-Sided Copy

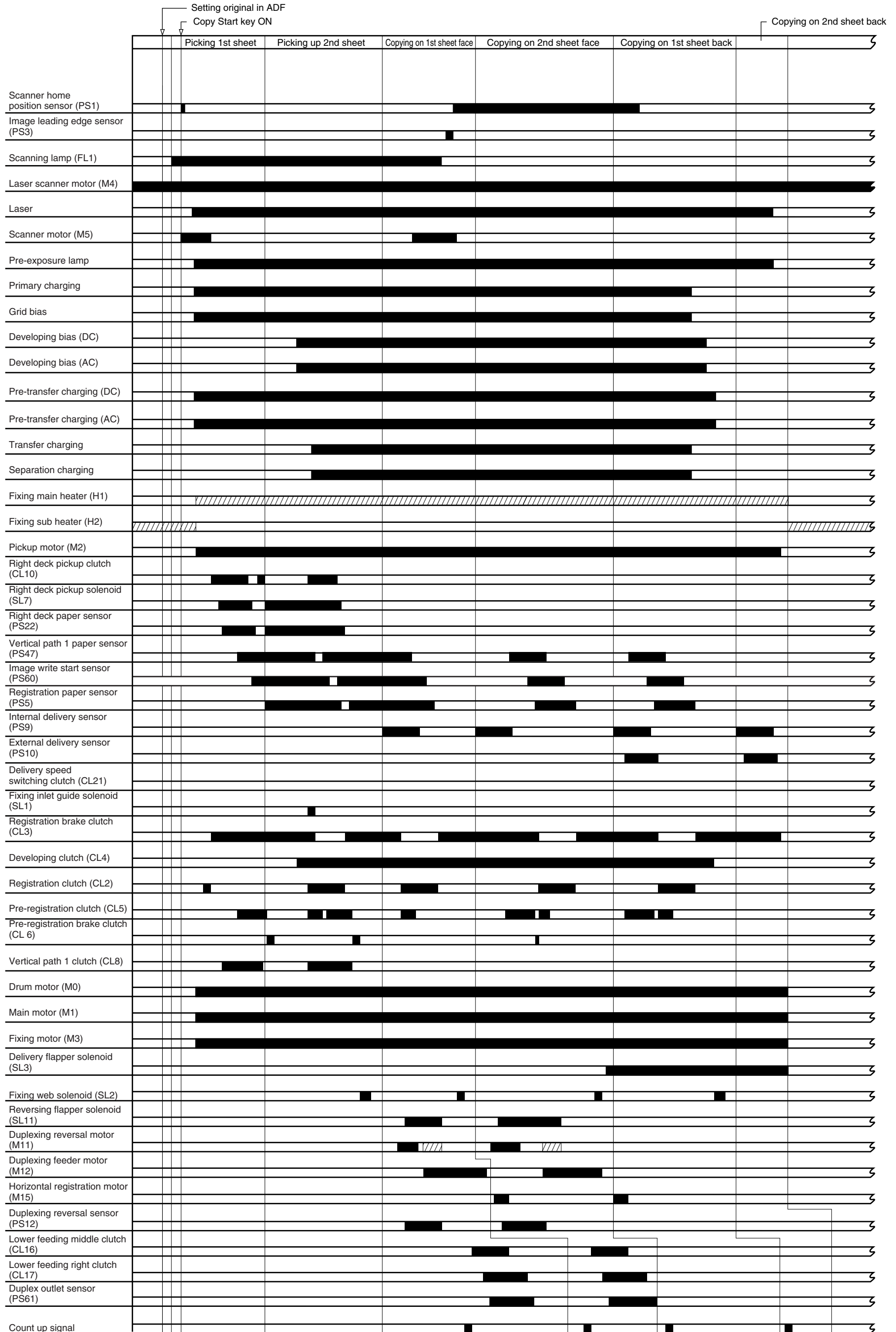

2 LIST OF SIGNALS/ABBREVIATIONS

The following is a list of the signals and abbreviations used in this chapter and the circuit diagrams.



The abbreviations in parentheses are electrical signals, but are analog signals, which cannot be expressed in terms of '1' or '0'. Others are digital signals, which may be expressed in terms of '1' or '0'.

AFTER_JOIN_PS	Post-confluence sensor detection signal
BUFFER_CL	Hopper internal magnet roller drive clutch drive command
BUFFER_MOTOR(-)	Hopper internal toner feeder motor drive command 2
BUFFER_MOTOR(+)	Hopper internal toner feeder motor drive command 1
BUFFER_NG	Hopper internal toner lower limit sensor detection signal
BUFFER_WARNING	Hopper internal toner sensor detection signal
C3_FEED_CL_ON	Cassette 3 pickup clutch drive command
C3_FEED_PS	Cassette 3 pickup sensor detection signal
C3_LENGTH	Cassette 3 paper length sensor detection signal
C3_LIFT_PS	Cassette 3 lifter sensor detection signal
C3_LIFTER_MOTOR	Cassette 3 lifter motor drive command
C3_OPEN_PS	Cassette 3 open/closed sensor detection signal
C3_PAPER_PS	Cassette 3 paper sensor detection signal
C3_PICKUP_SL	Cassette 3 pickup solenoid drive command
C3_PLEVER_VR	Cassette 3 paper level detection signal
C3VR	Cassette 3 paper width volume detection signal
C4_FEED_CL_ON	Cassette 4 pickup clutch drive command
C4_FEED_PS	Cassette 4 pickup sensor detection signal
C4_LENGTH	Cassette 4 paper length sensor detection signal
C4_LIFT_PS	Cassette 4 lifter sensor detection signal
C4_LIFTER_MOTOR	Cassette 4 lifter motor drive command
C4_OPEN_PS	Cassette 4 open/closed sensor detection signal
C4_PAPER_PS	Cassette 4 paper sensor detection signal
C4_PICKUP_SL_ON	Cassette 4 pickup solenoid drive command
C4_PLEVER_VR	Cassette 4 paper level detection signal
C4VR	Cassette 4 paper width volume detection signal
CARTRIGE_DETECT	Cartridge detecting switch detection signal
CARTRIGE_MOTOR-	Cartridge internal toner feeder motor drive command
CARTRIGE_MOTOR+	Cartridge internal toner feeder motor drive command
CARTRIGE_OPEN_PS	Toner cartridge cover open/closed sensor detection signal
CLEW_PS	Fixing claw jam sensor detection signal
CURL_FAN_STOP	De-curling fan lock detection signal
DCP_FAN1_STOP	Power supply cooling fan 1 lock detection signal
DCP_FAN2_STOP	Power supply cooling fan 2 lock detection signal
DECK_PULL_PS	Front deck (left) feeding sensor detection signal

DEV_FAN_STOP	Developing fan lock detection signal
DEV_SLEEVE_CL_ON	Developing cylinder deceleration clutch drive command
DEV1_SLEEVE_CL_ON	Developing clutch drive command
DEVELOP_IS	Developing assembly internal toner sensor detection signal
DOCUMENT_TOP	Image leading edge sensor detection signal
DRUM_FAN_STOP	Drum fan lock detection signal
DRUN_MOTOR_LOCK	Drum motor lock detection signal
DRUN_MOTOR_ON	Drum motor drive command
DUP-INV_PS	Duplexing reversal sensor detection signal
EXHAUST_FAN_STOP	Fixing assembly heat discharge fan lock detection signal
EXIT_DEL_PS	External delivery sensor detection signal
EXIT_FAN1_LOCK	Delivery adhesion-proofing fan lock detection signal
FEED_MOTOR_FG	Pickup motor frequency signal
FEED_MOTOR_ON	Pickup motor drive command
FIXEXIT_DEL_PS	Fixing feeding unit outlet sensor detection signal
FL_TH	Scanning lamp thermal sensor detection signal
FLAP_SL	Delivery flapper solenoid drive command
FREAD_FAN_STOP	Stream reading fan lock detection signal
FRONT_DR_OPEN	Front cover open/closed detecting switch detection signal
FRONT_JOIN_PS	Pre-confluence sensor detection signal
FUSE_M_LOCK	Fixing motor lock detection signal
FUSE_M_ON	Fixing motor drive command
GLASS_PS	Copyboard glass sensor detection signal
INT_DEL_PS	Internal delivery sensor detection signal
INV_FAN_STOP	Inverter cooling fan lock detection signal
INV_GUIDE_SL	Reversing flapper solenoid drive command
KAKIKOMI_PS	Image write start sensor detection signal
LASER1_FAN_STOP	Scanner cooling fan lock detection signal
LASER2_FAN_STOP	Laser driver cooling fan lock detection signal
LDECK_FEED_CL	Deck (left) pickup clutch drive command
LDECK_FEED_PS	Front deck (left) pickup sensor detection signal
LDECK_LIFT_MOTOR	Deck (left) lifter motor drive command
LDECK_LIFT_PS	Front deck (left) lifter sensor detection signal
LDECK_LIMIT_PS	Front deck (left) limit sensor detection signal
LDECK_OPEN_PS	Front deck (left) open/closed sensor detection signal
LDECK_PAPER_PS	Front deck (left) paper sensor detection signal
LDECK_PICKUP_SL	Deck (left) pickup solenoid drive command
LDECK_PLEVEL_M	Front deck (left) paper level middle sensor detection signal
LDECK_PLEVEL_U	Front deck (left) paper level high sensor detection signal
LDECK_PULL_CL	Deck (left) feeding clutch drive command
LOCK	System fan lock detection signal
LOCK	Duplex feed fan lock detection signal
LOW_DR_OPEN	Lower right cover open/closed sensor detection signal
LOWPASS_C_CL	Lower feeding middle clutch drive command

LOWPASS_R_CL	Lower feeding right clutch drive command
MAIN_MOTOR_FG	Main motor frequency signal
MAIN_MOTOR_ON	Main motor drive command
MAIN_TENP	Fixing main thermistor detection signal
MLT_CURL_ENTRY	Manual feed sensor detection signal
MLT_DR_OPEN	Manual feed tray cover open/closed sensor detection signal
MLT_FEED_CL	Manual feed tray pickup clutch drive command
MLT_PAPER_PS	Manual feed tray paper sensor detection signal
MLT_PICKUP_SL_BACK	Manual feed pickup clutch solenoid drive command
MLT_PICKUP_SL_PULL	Manual feed pickup clutch solenoid drive command
MLT_PULL_CL	Manual feed tray feeding clutch drive command
MLT_VOLUME	Manual feed tray paper width volume detection signal
MOTOR_ON	Vibration motor drive command
MUTI DOOR OPEN	Manual feed tray cover open/closed detecting sensor detection signal
OPT_HP1	Scanner home position sensor detection signal
OPT_MOTOR_FAN_STOP	Scanner moter cooling fan lock detection signal
ORI_SIZE_ON/OFF	Original size sensor ON/OFF detection signal
ORI_SIZE1	Original size sensor detection signal 1
ORI_SIZE2	Original size sensor detection signal 2
ORI_SIZE3	Original size sensor detection signal 3
ORI_SIZE4	Original size sensor detection signal 4
PATH1_CL_ON	Vertical path 1 clutch drive command
PATH1_PS	Vertical path 1 paper sensor detection signal
PATH2_CL_ON	Vertical path 2 clutch drive command
PATH2_PS	Vertical path 2 paper sensor detection signal
PATH3_CL_ON	Vertical path 3 clutch drive command
PATH3_PS	Vertical path 3 paper sensor detection signal
PATH4_CL_ON	Vertical path 4 clutch drive command
PATH4_PS	Vertical path 4 paper sensor detection signal
POST_FAN_STOP	Pre-transfer charging fan lock detection signal
POST_M.C_BK	Pre-transfer charging wire cleaning motor drive command (reverse)
POST_M.C_FW	Pre-transfer charging wire cleaning motor drive command (forward)
POTENTIAL_ON	Potential sensor detection signal
POTENTIAL_SIG	Potential sensor detection signal
PRESSING_PLATE_OPEN	Copyboard cover open/closed sensor detection signal
PRIM_FAN_STOP	Primary charging assembly fan lock detection signal
PRIMARY_V.C_BK	Primary charging wire cleaning motor drive command (reverse)
PRIMARY_V.C_FW	Primary charging wire cleaning motor drive command (forward)
PRIREGI_BRAKE_CL_ON	Pre-registration brake clutch drive command

PRIREGI_CL_ON	Pre-registration clutch drive command
RDECK_FEED_CL	Deck (right) pickup clutch drive command
RDECK_FEED_PS	Front deck (right) pickup sensor detection signal
RDECK_LIFT_MOTOR(24VU)	Deck (right) lifter motor drive command
RDECK_LIFTER_PS	Front deck (right) lifter sensor detection signal
RDECK_LIMIT_PS	Front deck (right) limit sensor detection signal
RDECK_OPEN_PS	Front deck (right) open/closed sensor detection signal
RDECK_PAPER_PS	Front deck (right) paper sensor detection signal
RDECK_PICKUP_SL_ON	Deck (right) pickup solenoid drive command
RDECK_PLEVEL_M	Front deck (right) paper level middle sensor detection signal
RDECK_PLEVEL_U	Front deck (right) paper level high sensor detection signal
RDECK_PULL_PS	Front deck (right) feeding sensor detection signal
REGI_BRAKE_CL	Registration brake clutch drive command
REGIST_CL	Registration clutch drive command
REGIST_PS	Registration paper sensor detection signal
REVER_OPEN_PS	Fixing/feeding unit releasing lever sensor detection signal
RUP_DR_OPEN	Upper right cover open/closed sensor detection signal
SEP_EXAUST_FAN_STOP	Scanner motor cooling fan lock detection signal
SIDE_REGI_PS	Horizontal registration sensor detection signal
SPEED_DEL_CL	Delivery speed switching clutch drive command
STOP	Separation fan lock detection signal
SUB_TEMP	Fixing sub thermistor detection signal
T/S_W.C_OUT1	Transfer/separation charging wire cleaning motor drive command 1
T/S_W.C_OUT2	Transfer/separation charging wire cleaning motor drive command 2
TERN_HUM_SENSOR	Environment sensor detection signal
UNITLOCK_SL_BACK	Fixing feeding unit locking solenoid drive command (back)
UNITLOCK_SL_PULL	Fixing feeding unit locking solenoid drive command (pull)
U-TURN_PS	Duplex outlet sensor detection signal
VASIE_TONER_PACKED_DTC	Waste toner clog detecting switch detection signal
WASTE_TONER_OVER_PS	Waste toner case full sensor detection signal
WEB_LESS	Fixing cleaning belt sensor detection signal
WEB_SL	Fixing cleaning belt solenoid drive command
WEB_WARNING	Fixing cleaning belt warning sensor detection signal

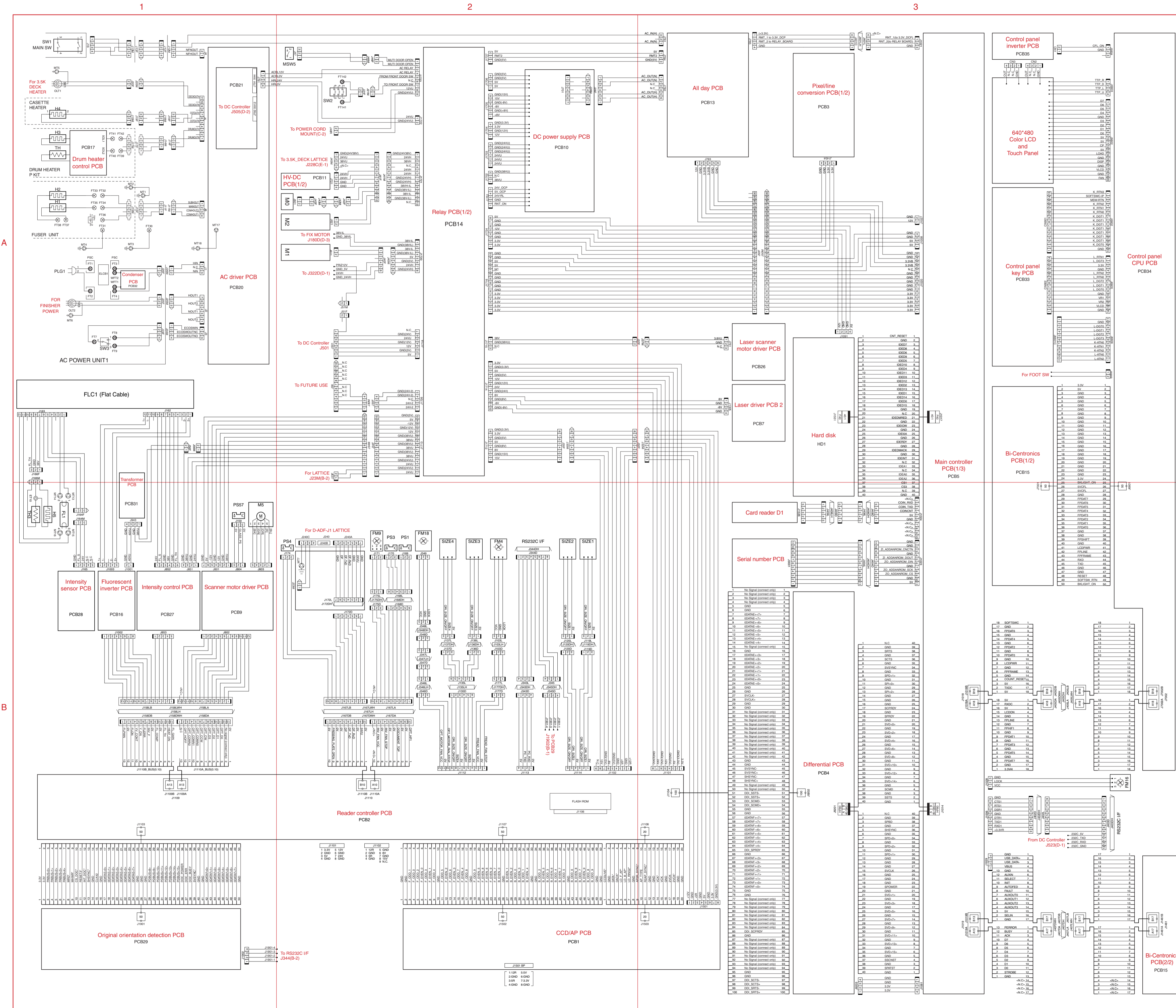

MAP	NAME
PS1	B-2 Scanner home position sensor
PS3	B-2 Image leading edge sensor
PS4	B-2 ADF open/closed sensor
PS7	B-1 Copyboard glass sensor
MSWS	A-2 Manual feed tray cover open/closed detection sensor
SIZE1	B-2 Original size sensor 1
SIZE2	B-2 Original size sensor 2
SIZE3	B-2 Original size sensor 3
SIZE4	B-2 Original size sensor 4
TH3	B-1 Thermal sensor
M0	A-2 Drum motor
M1	A-2 Main motor
M2	A-2 Pickup motor
M5	B-1 Scanner motor
FM4	B-2 Stream reading fan
FM9	B-2 Inverter cooling fan
FM16	B-3 System fan
FM18	B-2 Scanner motor cooling fan
FL1	B-1 Scanning lamp
H1	A-1 Fixing main heater
H2	A-1 Fixing sub heater
H3	A-1 Drum heater
H4	A-1 Cassette heater
H5	B-1 Scanning lamp heater
SW1	A-1 Main switch
SW2	A-2 Front cover switch
SW3	A-1 Environment switch
TP1	A-1 Fixing heater thermal switch
ELCB1	A-1 Leakage breaker
HD1	A-3 Hard disk

MAP	NAME
PCB1	B-2 CCD/AP PCB
PCB2	B-2 Reader controller PCB
PCB3	A-3 C-3 Pixel/line conversion PCB
PCB4	B-3 Differential PCB
PCB5	A-3 C-3 D-1 Main controller PCB
PCB6	D-3 DC controller PCB
PCB7	C-3 Laser driver PCB 1
PCB8	A-3 C-3 Laser driver PCB 2
PCB9	B-1 Scanner motor driver PCB
PCB10	A-2 DC power supply PCB
PCB11	A-2 E-2 HV-DC PCB
PCB12	E-3 HV-AC PCB
PCB13	A-3 All day PCB
PCB14	A-2 C-2 Relay PCB
PCB15	A-3 B-3 Bi-Centronics PCB
PCB16	B-1 Fluorescent inverter PCB
PCB17	A-1 Drum heater control PCB
PCB18	D-3 BD PCB
PCB19	C-1 Potential control PCB
PCB20	A-1 AC driver PCB
PCB21	A-1 AC driver sub PCB
PCB22	D-2 Environment sensor PCB
PCB23	D-1 No-stacking PCB
PCB24	D-2 Cassette 3 paper level detection PCB
PCB25	D-2 Cassette 4 paper level detection PCB
PCB26	C-1 Laser scanner motor driver PCB
PCB27	B-1 Intensity control PCB
PCB28	B-1 Intensity sensor PCB
PCB29	B-1 Original orientation detection PCB
PCB30	B-3 Serial number PCB
PCB31	B-1 Transformer PCB
PCB32	A-1 Condenser PCB
PCB33	A-3 Control panel CPU PCB
PCB34	A-3 Control panel key PCB
PCB35	A-3 Control panel inverter PCB
A-3	Color LCD and Touch Panel

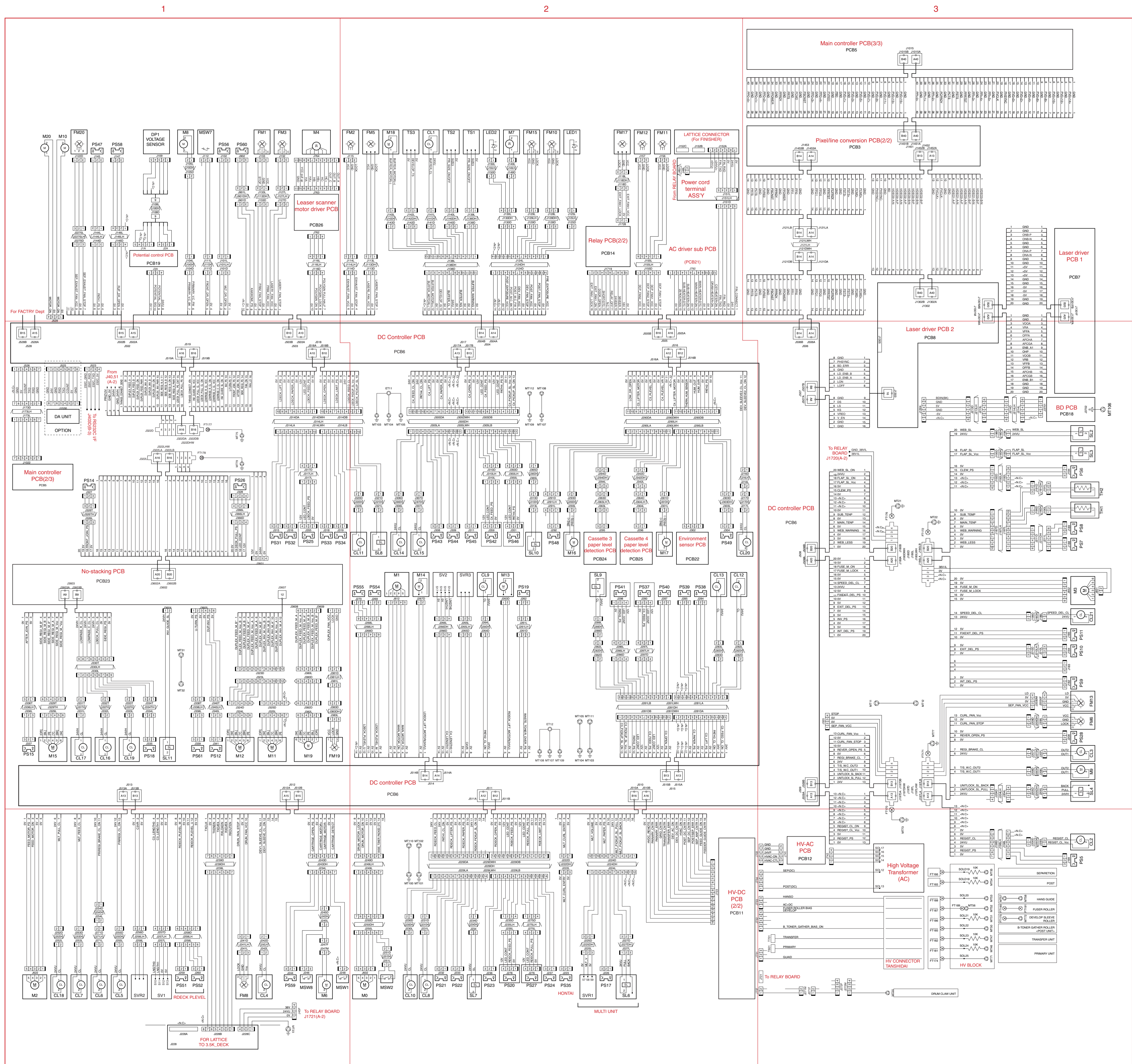

MAP	NAME
PS5	E-3 Registration paper sensor
PS6	D-3 Fixing claw jam sensor
PS7	D-3 Fixing cleaning belt sensor
PS8	D-3 Fixing cleaning belt warning sensor
PS9	D-3 Internal delivery paper sensor
PS10	D-3 External delivery paper sensor
PS11	D-3 Fixing feeding unit outlet paper sensor
PS12	D-1 Duplexing reversal paper sensor
PS14	D-1 Pre-confluence paper sensor
PS15	D-1 Post-confluence paper sensor
PS17	E-2 Manual feed tray paper detection sensor
PS18	D-1 Horizontal registration paper sensor
PS19	D-2 Waste toner case full sensor
PS20	E-2 Front deck (right) pickup paper sensor
PS21	E-2 Front deck (right) lifter position sensor
PS22	E-2 Front deck (right) paper sensor
PS23	E-2 Front deck (right) open/closed sensor
PS24	E-2 Front deck (right) lifter upper limit sensor
PS25	D-1 Front deck (left) pickup paper sensor
PS26	D-1 Front deck (left) feeding paper sensor
PS27	E-2 Front deck (left) paper sensor
PS28	D-3 Fixing/feeding unit releasing lever sensor
PS31	D-1 Front deck (left) lifter position sensor
PS32	D-1 Front deck (left) paper sensor
PS33	D-1 Front deck (left) open/closed sensor
PS34	D-1 Front deck (left) lifter upper limit sensor
PS35	E-2 Manual feed tray de-curling inlet paper sensor
PS37	D-2 Cassette 3 pickup paper sensor
PS38	D-2 Cassette 3 lifter position sensor
PS39	D-2 Cassette 3 paper sensor
PS40	D-2 Cassette 3 open/closed sensor
PS41	D-2 Vertical path 3 roller paper sensor
PS42	D-2 Cassette 4 pickup paper sensor
PS43	D-2 Cassette 4 lifter position sensor
PS44	D-2 Cassette 4 paper sensor
PS45	D-2 Cassette 4 open/closed sensor
PS46	D-2 Vertical path 4 roll paper sensor
PS47	C-1 Vertical path roller 1 paper sensor
PS48	D-2 Lower right cover open/closed sensor
PS49	C-2 Vertical path 2 roller paper sensor
PS51	E-1 Front deck (right) medium level paper sensor
PS52	E-1 Front deck (right) upper level paper sensor
PS54	D-2 Front deck (left) medium level paper sensor
PS55	D-2 Front deck (left) upper level paper sensor
PS56	C-1 Manual feed tray cover open/closed sensor
PS58	C-1 Middle right cover open/closed sensor
PS59	E-1 Toner cartridge cover open/closed sensor
PS60	C-1 Image write start sensor
PS61	D-1 Duplex outlet sensor
MSW1	E-1 Cartridge sensor
MSW2	E-2 Waste toner clogging sensor
MSW7	C-1 Front cover open/closed sensor
MSW8	E-1 Cartridge motor drive
SV1	E-1 Cassette 3 paper length sensor
SV2	D-2 Cassette 4 paper length sensor
SVR1	E-2 Manual feed tray paper width sensor
SVR2	E-1 Cassette 3 paper width sensor
SVR3	D-2 Cassette 4 paper width sensor
TS1	C-2 Hopper inside toner level sensor
TS2	C-2 Hopper inside toner lower limit sensor
TS3	C-2 Developing assembly inside toner level sensor
TH1	D-3 Fixing heater main thermistor
TH2	D-3 Fixing heater sub thermistor (end part)
DP1	C-1 Drum surface potential measurement
CL1	C-2 Hopper clutch
CL2	E-3 Registration roller clutch
CL3	D-3 Registration roller brake clutch
CL4	E-1 Developing cylinder clutch
CL5	E-1 Pre-registration roller clutch
CL6	E-1 Pre-registration roller brake clutch
CL7	E-1 Manual feed tray pickup roller clutch
CL8	E-2 Vertical path 1 roller clutch
CL9	D-2 Vertical path 2 roller clutch
CL10	E-2 Front deck (right) pickup roller clutch
CL11	D-2 Front deck (left) pickup roller clutch
CL12	D-2 Cassette 3 pickup roller clutch
CL13	D-2 Vertical path 3 roller clutch
CL14	D-2 Cassette 4 pickup roller clutch
CL15	D-2 Vertical path 4 roller clutch
CL16	D-1 Lower feeding middle roller clutch
CL17	D-1 Lower feeding right roller clutch
CL18	E-1 Manual feed tray feeding roller clutch
CL19	D-1 Front deck (left) feeding roller clutch
CL20	D-2 Developing cylinder deceleration clutch
CL21	D-3 Switches delivery speed clutch
SL2	D-3 Fixing cleaning belt solenoid
SL3	D-3 Delivery flapper solenoid
SL4	D-3 Locks the fixing/feeding unit solenoid
SL6	E-2 Manual feed tray pickup latch solenoid
SL7	E-2 Front deck (right) pickup mechanism solenoid
SL8	D-2 Front deck (left) pickup mechanism solenoid
SL9	D-2 Cassette 3 pickup mechanism solenoid
SL10	D-2 Cassette 4 pickup mechanism solenoid
SL11	D-1 Reversing flapper solenoid
M0	E-2 Drum motor
M1	M-2 Main motor
M2	E-1 Pickup motor
M3	D-3 Fixing motor
M4	C-1 Laser scanner motor
M6	E-1 Cartridge motor
M7	C-2 Pre-transfer charging wire cleaner motor
M8	C-1 Primary charging wire cleaner motor
M9	D-3 Transfer separation charging wire cleaner motor
M10	C-1 Vibration motor
M11	D-1 Reversal motor
M12	D-1 Duplexing feeding left motor
M13	D-2 Front deck (right) lifter motor
M14	D-2 Front deck (left) lifter motor
M15	D-1 Horizontal registration motor
M16	D-2 Cassette 3 lifter motor
M17	D-2 Cassette 4 lifter motor
M18	C-2 Hopper inside toner feeder motor
M19	D-1 Duplexing feeding right motor
M20	C-1 Vibration motor
FM1	C-1 Primary charging fan
FM2	C-2 Fixing heat discharge fan
FM3	C-1 Scanner cooling fan
FM5	C-2 Laser driver cooling fan
FM6	D-3 Curl removing fan
FM8	E-1 Drum fan
FM10	C-2 Pre-transfer charging assembly fan
FM11	C-2 Power supply cooling fan 1
FM12	C-2 Power supply cooling fan 2
FM13	D-3 Separation fan
FM15	C-2 Development fan
FM17	C-2 Delivery adhesion-proofing fan
FM19	D-1 Duplex feed fan
FM20	C-1 Separation heat discharge fan
LED1	C-2 Pre-exposure lamp
LED2	C-2 Pre-transfer exposure lamp

4 Special Tools Table

You will need the following tools in addition to the standard tools set to service the copier.

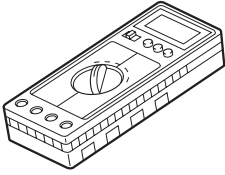
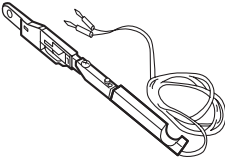
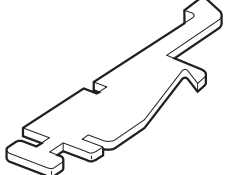
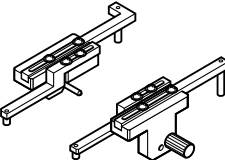
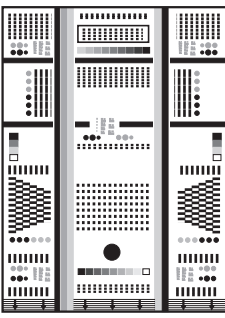
No.	Tool name	Tool No.	Shape	Rank*	Remarks
1	Digital multimeter	FY9-2002		A	For adjusting the laser intensity together with the laser power checker (for electrical checks).
2	Laser power checker	FY9-4008		A	For adjusting the light intensity together with the digital multimeter.
3	Door switch	TKN-0093		A	
4	Mirror positioning tool (front, rear)	FY9-3040		B	For adjusting the distance between No. 1 and No. 2 mirrors.
5	NA-3 test sheet	FY9-9196		A	For adjusting images and making checks.

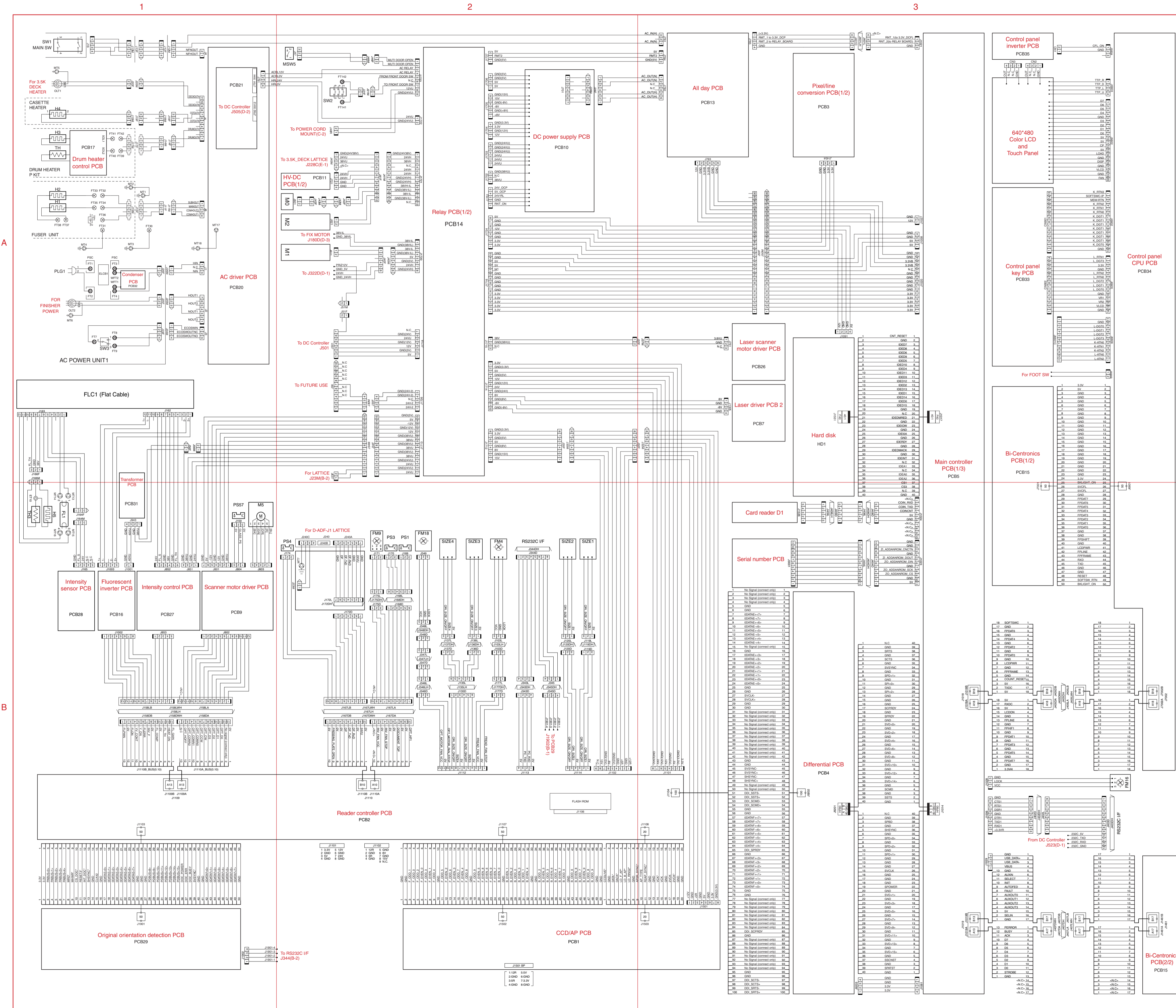

MAP	NAME
PS1	B-2 Scanner home position sensor
PS3	B-2 Image leading edge sensor
PS4	B-2 ADF open/closed sensor
PS7	B-1 Copyboard glass sensor
MSWS	A-2 Manual feed tray cover open/closed detection sensor
SIZE1	B-2 Original size sensor 1
SIZE2	B-2 Original size sensor 2
SIZE3	B-2 Original size sensor 3
SIZE4	B-2 Original size sensor 4
TH3	B-1 Thermal sensor
M0	A-2 Drum motor
M1	A-2 Main motor
M2	A-2 Pickup motor
M5	B-1 Scanner motor
FM4	B-2 Stream reading fan
FM9	B-2 Inverter cooling fan
FM16	B-3 System fan
FM18	B-2 Scanner motor cooling fan
FL1	B-1 Scanning lamp
H1	A-1 Fixing main heater
H2	A-1 Fixing sub heater
H3	A-1 Drum heater
H4	A-1 Cassette heater
H5	B-1 Scanning lamp heater
SW1	A-1 Main switch
SW2	A-2 Front cover switch
SW3	A-1 Environment switch
TP1	A-1 Fixing heater thermal switch
ELCB1	A-1 Leakage breaker
HD1	A-3 Hard disk

MAP	NAME
PCB1	B-2 CCD/AP PCB
PCB2	B-2 Reader controller PCB
PCB3	A-3-C-3 Pixel/line conversion PCB
PCB4	B-3 Differential PCB
PCB5	A-3-C-3-D-1 Main controller PCB
PCB6	D-3 DC controller PCB
PCB7	C-3 Laser driver PCB 1
PCB8	A-3-C-3 Laser driver PCB 2
PCB9	B-1 Scanner motor driver PCB
PCB10	A-2 DC power supply PCB
PCB11	A-2-E-2 HV-DC PCB
PCB12	E-3 HV-AC PCB
PCB13	A-3 All day PCB
PCB14	A-2-C-2 Relay PCB
PCB15	A-3-B-3 Bi-Centronics PCB
PCB16	B-1 Fluorescent inverter PCB
PCB17	A-1 Drum heater control PCB
PCB18	D-3 BD PCB
PCB19	C-1 Potential control PCB
PCB20	A-1 AC driver PCB
PCB21	A-1 AC driver sub PCB
PCB22	D-2 Environment sensor PCB
PCB23	D-1 No-stacking PCB
PCB24	D-2 Cassette 3 paper level detection PCB
PCB25	D-2 Cassette 4 paper level detection PCB
PCB26	C-1 Laser scanner motor driver PCB
PCB27	B-1 Intensity control PCB
PCB28	B-1 Intensity sensor PCB
PCB29	B-1 Original orientation detection PCB
PCB30	B-3 Serial number PCB
PCB31	B-1 Transformer PCB
PCB32	A-1 Condenser PCB
PCB33	A-3 Control panel CPU PCB
PCB34	A-3 Control panel key PCB
PCB35	A-3 Control panel inverter PCB
A-3	Color LCD and Touch Panel

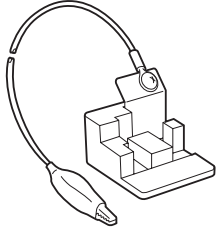
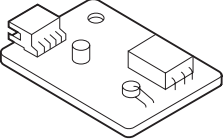
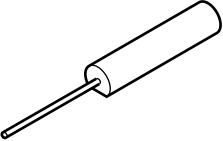
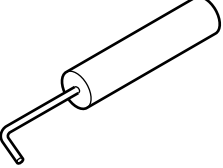
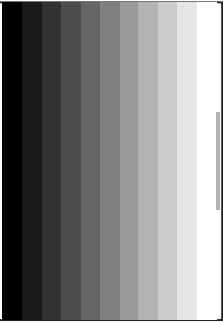
No.	Tool name	Tool No.	Shape	Rank*	Remarks
6	Potential sensor tester electrode	FY9-3041		B	For checking the zero level of the surface potential sensor.
7	Environment sensor meter sensor	FY9-3014		B	For checking the environment sensor.
8	Tester extension pin	FY9-3038		A	For making electrical checks (attachment to the meter).
9	Tester extension Pin (L-tipped)	FY9-3039		A	For making electrical checks (attachment to the meter).
10	D-10 Test Sheet	FY9-9129-000		B	For adjusting images.

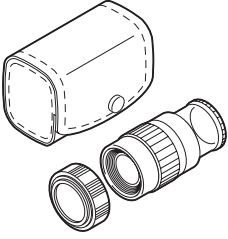
No.	Tool name	Tool No.	Shape	Rank*	Remarks
11	Loupe	CK-0056-000		B	For checking images.

*Rank:

- A: Each service person is expected to carry one.
- B: Each five or so service persons is expected to carry one.
- C: Each workshop is expected to carry one.

5 Solvents/Oils

No.	Name	Uses	Composition	Remarks
1	Alcohol	Cleaning; e.g., glass, plastic, rubber (external covers)	Hydrocarbon of the fluorine family, alcohol, surface activating agent, water	<ul style="list-style-type: none"> • Do not bring near fire. • Procure locally. • IPA (isopropyl alcohol)
2	Solvent	Cleaning; e.g., metal areas; removing oil or toner.	Hydrocarbon of fluorine family, hydrocarbon of chlorine family, alcohol	<ul style="list-style-type: none"> • Do not bring near fire. • Procure locally.
3	Heat-resisting grease	Lubricating; e.g., fixing drive parts.	Lithium soap of mineral family, molybdenum disulfide	• CK-0427 (500 g/can)
4	Lubricant		Mineral oil (paraffin family)	• CK-0524 (100 cc)
5	Lubricant	Lubricating; e.g., friction parts.	Silicone oil	• CK-0551 (20 g)
6	Drum cleaning powder	Cleaning; e/g., photosensitive drum.	Selenium oxide	• CK-0429
7	Lubricant	Lubricating; e.g., scanner rail.	Silicone oil	• FY9-6011 (50 cc)
8	Conducting grease	Drum heater contact	Fluorine poly ethyl, Poly tetra fluorine ethylene	• FY9-6008 (10 g)

Service Mode

1 Construction of Service Mode

1.1 Outline

The service mode screens are arranged in a 3-level construction: Initial screen, Level 1/2 screen, Level 3 screen.

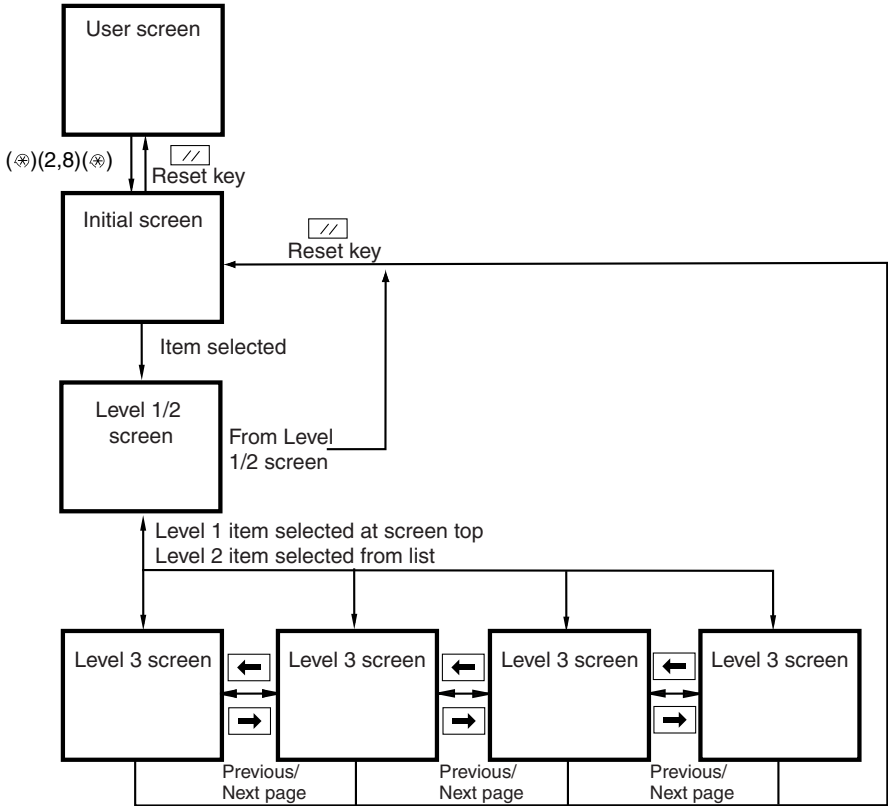

F00-101-01

The machine's service mode consists of the following 7 types:

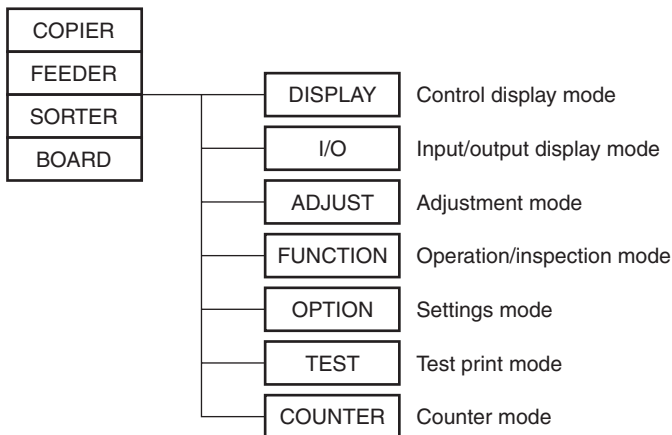

F00-101-02

1.2 Starting Service Mode and Making Selections

- 1) Press the User Mode key “

The following Initial screen will appear as a result:

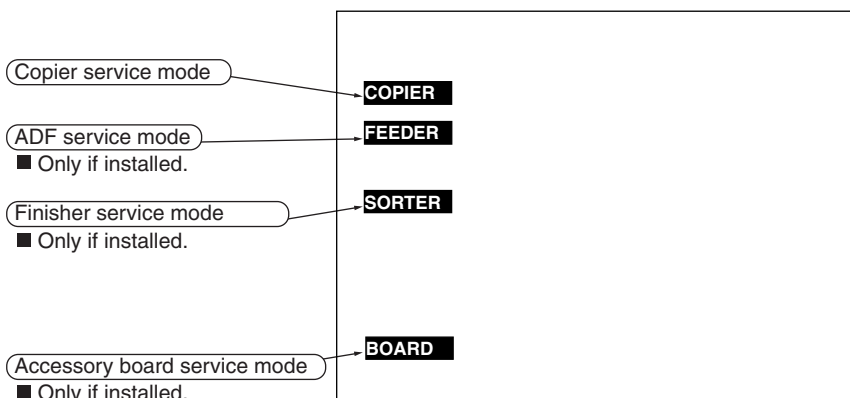

F00-102-01

1.3 Ending Service Mode

- Press the Reset key once to return to the Service Mode Initial screen (F00-102-01).
- Press the Reset key twice to leave service mode and return to the User screen (Standard screen).



If you used service mode (ADJUST, FUNCTION, OPTION), be sure to turn off and then on the main power switch after leaving service mode.

1.4 Backing Up Service Mode Settings

At time of shipment from the factory, each machine is adjusted, and the adjustment values are recorded in the Service Sheet (found in the service book case behind the front cover).

If you have replaced the reader controller PCB or the DC controller PCB, or if you have executed RAM clear for each, the ADJUST and OPTION adjustment values will be initialized to their default settings. If you have made adjustments in the field, be sure to print out a service sheet (COPIER>FUNCTION>MISC-P>LBL-PRINT>OK), and store it away. If the sheet does not show a specific item, use its blank space.

You can also use service mode (COPIER>FUNCTION>MISC-P>P-PRINT>OK) to print out all service mode settings (i.e., under COPIER>ADJUST/OPTION/COUNTER) at once.

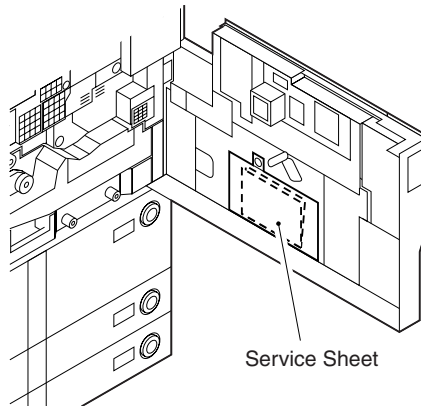

F00-104-01

1.5 Using Service Mode

1.5.1 Initial Screen

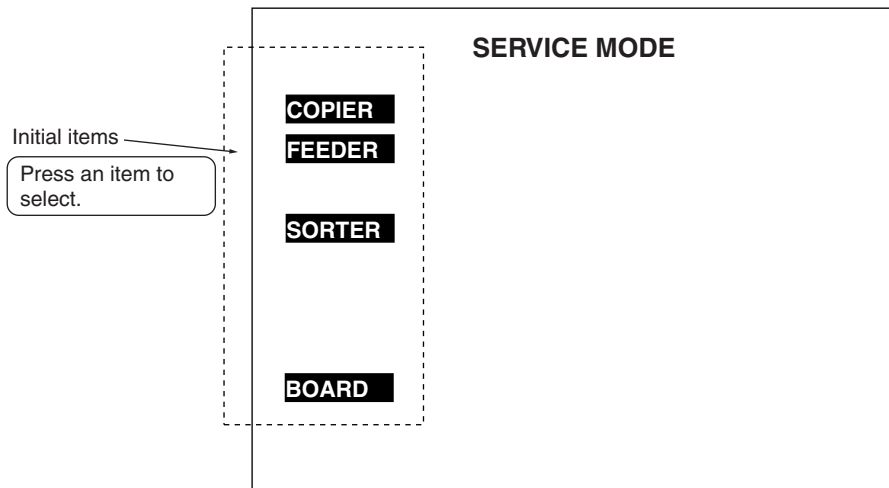

F00-105-01

1.5.2 Level 1/2 Screen

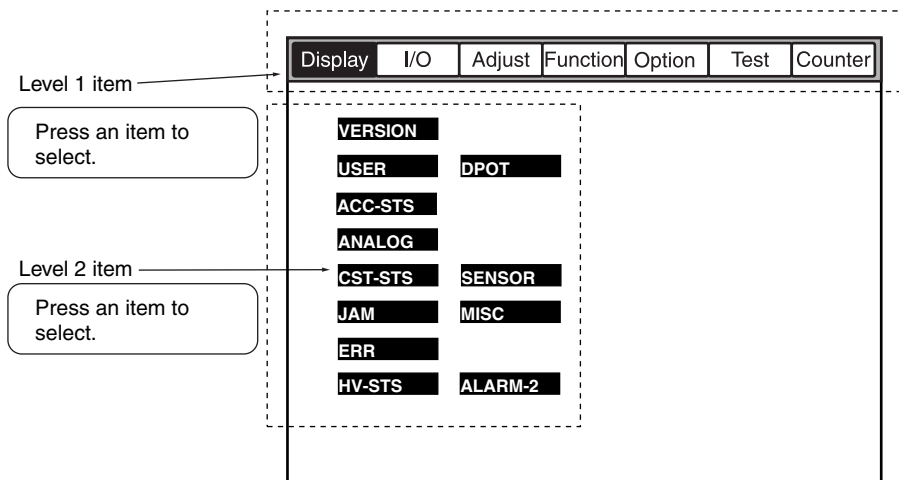

F00-105-02

1.5.3 Level 3 Screen

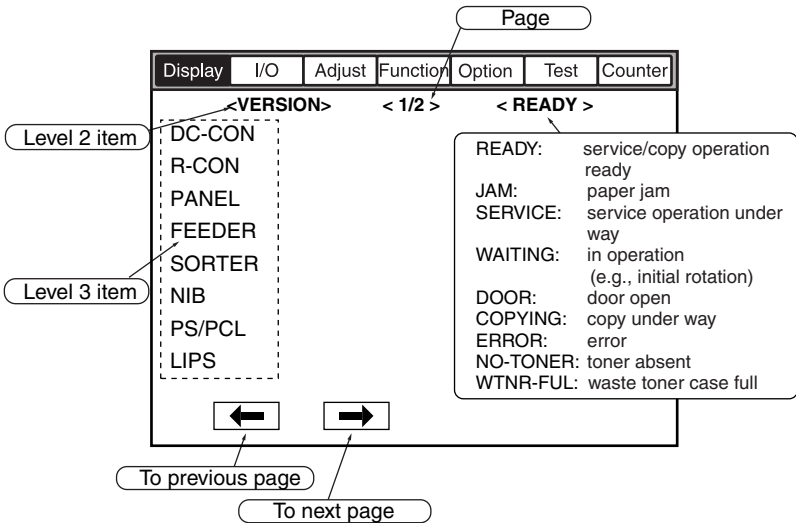

F00-105-03

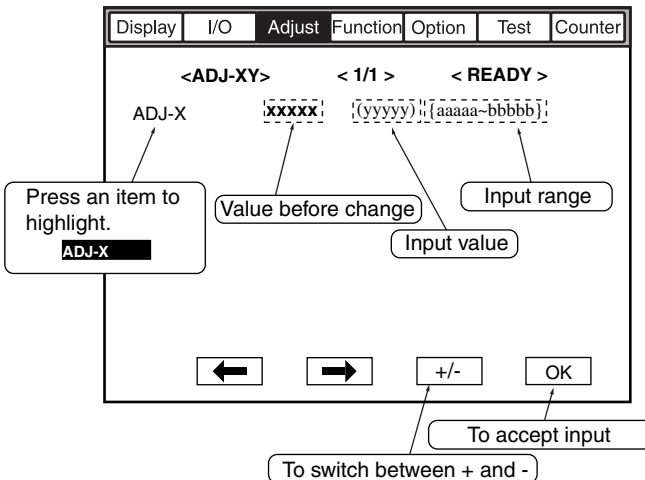

- Stop** key: press to stop ongoing operation.
- Clear** key: press to clear a value.
- Start** key: press to make a copy without leaving service mode.

F00-105-04

2 COPIER

2.1 DISPLAY

The following shows the Display screen (COPIER>DISPLAY):

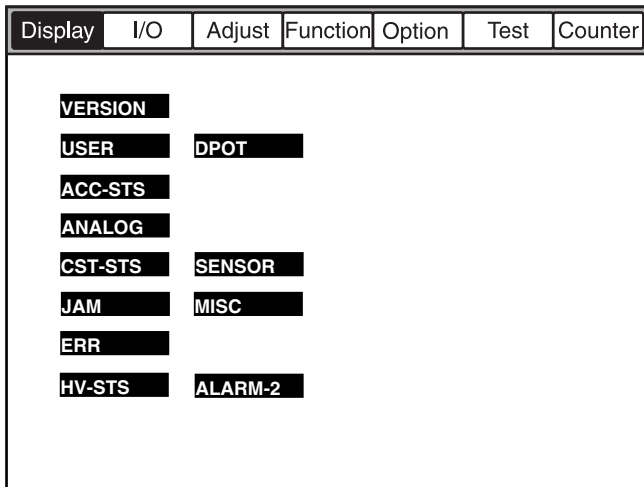

F00-201-01

<VERSION>

Indicates the ROM version of the machine and of the PCB of a specific accessory.
 Indication <xx, yy> xx: version number, yy: R&D control number

DC-CON	Indicates the ROM version of the DC controller PCB.
R-CON	Indicates the ROM version of the reader controller PCB.
PANEL	Indicates the ROM version of the control panel CPU PCB.
FEEDER	Indicates the ROM version of the ADF controller PCB.
SORTER	Indicates the ROM version of the finisher controller PCB.
NIB	Indicates the version of the network interface board.
PS/PCL	Indicates the version of the printer board (PS/PCL).
LIPS	Indicates the version of the printer board (LIPS).
SDL-STCH	Indicates the ROM version of the saddle stitcher controller PCB.
MN-CONT	Indicates the version of the software of the main controller PCB.
RIP1	not used
BOOT-ROM	Indicates the version of the boot ROM of the main controller.

COPIER>DISPLAY>VERSION

DIAG-DVC	Indicates the version of the self-diagnostic device.
RUI	Indicates the version of the remote UI.
LANG-EN	Indicates the version of the English language module.
LANG-FR	Indicates the version of the French language module.
LANG-DE	Indicates the version of the German language module.
LANG-IT	Indicates the version of the Italian language module.
LANG-JP	Indicates the version of the Japanese language module.
LANG-CS	Indicates the version of the Czech language module.
LANG-DA	Indicates the version of the Danish language module.
LANG-EL	Indicates the version of the Greek language module.
LANG-ES	Indicates the version of the Spanish language module.
LANG-ET	Indicates the version of the Estonian language module.
LANG-FI	Indicates the version of the Finnish language module.
LANG-HU	Indicates the version of the Hungarian language module.
LANG-KO	Indicates the version of the Korean language module.

LANG-NL	Indicates the version of the Dutch language module.
LANG-NO	Indicates the version of the Norwegian language module.
LANG-PL	Indicates the version of the Polish language module.
LANG-PT	Indicates the version of the Portuguese language module.
LANG-RU	Indicates the version of the Russian language module.
LANG-SL	Indicates the version of the Slovenian language module.
LANG-SV	Indicates the version of the Swedish language module.
LANG-TW	Indicates the version of the Chinese (classic) language module.
LANG-ZH	Indicates the version of the Chinese (simplified) language module.

COPIER>DISPLAY>USER
<USER>

Indicates items related to the User screen and the user.

LANGUAGE	<p>Indicates the language used/paper size configuration. Indication <LANGUAGE xxyy.zz.aa> xx (upper 2 digits): country code yy (lower 2 digits): language code zz: destination code (00: Canon, 01: OEM) aa: paper size configuration code (00: AB, 01: inch, 02: A, 03: all sizes)</p>
COUNTER	<p>Indicates the type of count control for the soft counter (00: 100 V, 01: 208/ 230 V)</p>
MODEL	<p>Indicates the type of model. 1: iR8500 2: iR105</p>

<ACC-STS>

Indicates the connection of accessories.

FEEDER	Indicates the connection of ADF. (0: absent, 1: present)
SORTER	Indicates the connection of a finisher and a puncher unit. Indication <u>XY</u> <u>X</u> = 0: finisher absent, 1: finisher, 2: saddle finisher, 3: saddle finisher + inserter, 4: saddle finisher + paper deck folding unit, 5: saddle finisher + inserter + paper folding unit <u>Y</u> = 0: puncher unit absent, 1: 2-hole, 2: 2/3-hole, 3: 4-hole (FRN), 4: 4-hole (SWDN)
DECK	Indicates the connection of a paper deck (accessory). (0: absent, 1: present)
CARD	Indicates the presence/absence of a card reader. (if no card reader is connected, '1') (0: absent, 1: present)
DATA-CON	Indicates the connection of a self-diagnostic device. (0: absent, 1: copy data controller, 2: NE controller)
RAM	Indicates the capacity of the memory mounted to the machine controller. (192 MB)
NIB	Indicates the connection of a network interface board. (0: absent, 1: Ether board, 2: TokenRing, 3: both)
LIPS-RAM	Indicates the capacity of the memory mounted to the LIPS board. (xx MB)

COPIER>DISPLAY>ANALOG

LIPS	Indicates the connection of the LIPS board. (0: absent, 1: present)
PS/PCL	Indicates the connection of the PS/PCL board. (0: absent, 1: PS/PCL, 2: PS Kanji)
RIP1	not used
NETWARE	Indicates the presence (installation) of the NetWare firmware. (0: absent, 1: installed)

<ANALOG>

Indicates the reading from the analog sensor.

TEMP	Indicates the machine internal temperature (environment sensor; °C).
HUM	Indicates the machine internal humidity (environment sensor; %).
ABS-HUM	Indicates the machine internal absolute humidity (absolute water content; g).
OPTICS	Indicates the temperature of the scanner (°C).
FIX-C	Indicates the temperature of the middle of the fixing upper roller (°C).
FIX-E	Indicates the temperature of the edge of the fixing upper roller (°C).

<CST-STS>

Indicates the paper size of the cassette and the manual feed tray.

WIDTH-C3	Indicates the width of paper in the cassette 3 in terms of paper size.
WIDTH-C4	Indicates the width of paper in the cassette 4 in terms of paper size.
WIDTH-MF	Indicates the width of paper in the manual feed tray.

COPIER>DISPLAY>JAM
<JAM>

Indicates the jam data.

Display	I/O	Adjust	Function	Option	Test	Counter
< JAM >		< 1/7 >		< READY >		
AA	BBBB	CCCC	DDDD	E	FFff	G HHHHHH IIIII
AA	BBBB	CCCC	DDDD	E	FFff	G HHHHHH IIIII
AA	BBBB	CCCC	DDDD	E	FFff	G HHHHHH IIIII
AA	BBBB	CCCC	DDDD	E	FFff	G HHHHHH IIIII
AA	BBBB	CCCC	DDDD	E	FFff	G HHHHHH IIIII
AA	BBBB	CCCC	DDDD	E	FFff	G HHHHHH IIIII
AA	BBBB	CCCC	DDDD	E	FFff	G HHHHHH IIIII
AA	BBBB	CCCC	DDDD	E	FFff	G HHHHHH IIIII
←		→				

F00-201-02

Item	Description	Remarks
AA	Order of jams (the higher, the older)	1 to 50 (50 max.)
BBBB	Date of occurrence	Month, day (2 digits each)
CCCC	Time of occurrence	24-hr notation
DDDD	Recovery time	24-hr notation (if no recovery, FFFF)
E	Location of occurrence	0: copier 1: feeder 2: finisher
FFff	Jam code	FF: type of copier jam (T00-201-01) ff: copier sensor (T00-201-02) FF: type of finisher jam (T00-201-03) ff: finisher jam sensor (T00-204-04) FFff: ADF jam code (T00-201-05) (T00-201-06)
G	Source of paper	
HHHHHH	Source soft counter	
IIII	Paper size	

COPIER>DISPLAY>JAM

FF: Type of Copier Jam

Code	Type
00xx	ADF jam
01xx	delay jam
02xx	stationary jam
0Axx	power-on residual jam
0Bxx	front cover open jam

T00-201-01

FF: Type of Finisher Jam

Code	Jam
10xx	delay jam
11xx	stationary jam
13xx	power-on residual jam
14xx	front cover open jam
15xx	staple jam
16xx	punch jam
17xx	other

ff: Copier Jam Sensor

Code	Sensor
xx00	no sensor in particular
xx01	right deck pickup sensor (PS20)
xx02	left deck pickup sensor (PS25)
xx03	cassette 3 pickup sensor (PS37)
xx04	cassette 4 pickup sensor (PS42)
xx05	vertical path 1 paper sensor (PS47)
xx06	vertical path 2 paper sensor (PS49)
xx07	vertical path 3 paper sensor (PS41)
xx08	vertical path 4 paper sensor (PS46)
xx09	registration paper sensor (PS5)
xx0A	fixing claw jam sensor (PS6)
xx0B	internal delivery sensor (PS9)
xx0C	external delivery sensor (PS10)
xx0D	fixing/feeder unit outlet sensor (PS11)
xx0F	duplexing reversal sensor (PS12)
xx10	duplexing outlet sensor (PS61)
xx11	pre-confluence sensor (PS14)
xx12	post-confluence sensor (PS15)
xx13	left deck feed sensor (PS26)
xx14	right deck feed sensor (PS27)
xx15	side paper deck feed sensor (PS106)
xx16	manual feed sensor (PS35)
xx17	side paper deck pickup sensor (PS101)

T00-201-02

T00-201-03

ff: Finisher Jam Sensor

Code	Sensor
xx00	no sensor in particular
xx11	fold path paper residual sensor 1 delay jam (PI73)
xx12	fold path paper residual sensor 2 delay jam (PI77)
xx13	fold path paper residual sensor 3 delay jam (PI75)
xx14	fold path paper residual sensor 4 delay jam (PI74)
xx15	saddle inlet sensor delay jam (PI59)
xx16	inlet path paper sensor delay jam (S1)
xx17	buffer path rear sensor delay jam (PI3)
xx18	non-sort delivery sensor delay jam (PI6)
xx19	sort delivery sensor delay jam (PI4)
xx1A	inserter separation sensor 1/2 delay jam (PI62/PI63)
xx1B	inserter feed sensor 3 delay jam (PI61)
xx21	feed path paper sensor 1 stationary jam (PI76)
xx22	feed path paper sensor 2 stationary jam (S7)
xx23	feed path paper sensor 3 stationary jam (S8)
xx24	feed path paper sensor 4 stationary jam (PI74)
xx25	saddle inlet sensor stationary jam (PI59)
xx26	inlet path paper sensor stationary jam (S1)

T00-201-04 (1/2)

SERVICE MODE

COPIER>DISPLAY>JAM

Code	Sensor
xx27	buffer path rear paper sensor stationary jam (PI3)
xx28	non-sort delivery sensor stationary jam (PI6)
xx29	sort delivery sensor stationary jam (PI4)
xx2A	inserter separation sensor 1/2 stationary jam (PI62/PI63)
xx2B	inserter feed path paper sensor 3 stationary jam (PI61)
xx2C	knurled belt HP sensor/stack delivery sensor stationary jam (PS31/32)
xx31	inserter paper set sensor pickup paper absent jam (S9)
xx32	shutter jam
xx33	inserter separation sensor 1/2 skew jam (PI62/PI63)
xx86	stitcher home position sensor front/rear staple jam (MS34/MS32)
xx87	No. 1 paper sensor /delivery sensor stationary jam (PI60/PI52)
xx88	outlet cover sensor/inlet cover sensor open jam (paper present) (PI46/PI51)
xx89	outlet cover sensor/inlet cover sensor open jam (paper absent) (PI46/PI51)
xx91	No. 1 paper sensor delay jam (PI60)
xx92	delivery sensor/vertical path paper sensor delay jam (PI52/PI57)
xxA1	No. 1/2/3 paper sensor stationary jam (PI60/61/62)
xxA2	delivery sensor/vertical path sensor stationary jam (PI52/PI57)

T00-201-04 (2/2)

FFff: ADF Jam Code

Code	Jam
0011	pickup trailing edge skew
0012	pickup fault 1
0013	pickup fault 2
0014	reversal delay
0015	reversal pickup trailing edge skew
0016	reversal pickup fault 1
0019	residual original
001A	1st sheet pickup trailing edge skew rear
001B	1st sheet reversal pickup trailing edge rear
001C	1st sheet pickup fault 1
001D	1st sheet pickup fault 2
001E	1st sheet reversal delay
001F	1st sheet reversal pickup fault 1
0022	separation delay
0023	pickup delay
0024	pickup leading edge skew
0025	pre-reversal delay 1
0026	pre-reversal delay 2
0027	pre-reversal delay 3
002A	1st sheet pickup leading edge skew
002B	1st sheet pre-reversal delay 1
002C	1st sheet pre-reversal delay 2
002D	1st sheet pre-reversal delay 3
0031	pickup stationary 1
0032	pickup stationary 2
0033	pre-reversal stationary 1
0034	pre-reversal stationary 2
0035	pre-reversal stationary 3
0036	pre-reversal stationary 4
003A	1st sheet pickup stationary 1
003B	1st sheet pickup stationary 2
003C	1st sheet pre-reversal stationary 1
003D	1st sheet pre-reversal stationary 2
003E	1st sheet pre-reversal stationary 3
003F	1st sheet pre-reversal stationary 4
0041	reversal stationary
004A	1st sheet reversal stationary

T00-201-05 (1/3)

COPIER>DISPLAY>JAM

Code	Jam	Code	Jam
0052	reversal pickup delay	00F8	reversal speed setting error
0054	reversal pickup stationary	00F9	reversal speed switch-cover error
0055	pre-reversal pickup delay	00FA	reversal status error
0056	pre-reversal pickup stationary 1	00FD	last sheet error
0057	pre-reversal pickup stationary 2	00FE	error
005A	1st sheet reversal pickup delay	00FF	program
005B	1st sheet reversal pickup stationary		
005C	1st sheet pre-reversal pickup delay		
005D	1st sheet pre-reversal pickup stationary 1		
005E	1st sheet pre-reversal pickup stationary 2		
0081	delivery delay		
0082	delivery stationary 1		
0083	delivery stationary 2		
008A	1st sheet delivery delay		
008B	1st sheet delivery stationary 1		
008C	1st sheet delivery stationary 2		
0092	manual feed registration delay		
00A1	manual feed registration stationary		
00A2	manual feed reversal stationary		
00A3	manual feed delivery stationary		
00A4	manual feed delivery delay		
00A5	manual feed residual original		
00A6	manual feed original size error		
00E1	ADF open		
00E2	cover open		
00E3	cycle NG		
00E4	initial stay		
00E5	timing error		
00E6	original size error		
00E7	user ADF open		
00E8	user cover open		
00E9	power-down		
00EA	time leading edge error		
00EB	1st sheet image leading position error		
00F1	belt speed setting error		
00F2	belt speed switch-over error		
00F3	belt status error		
00F4	image leading edge output timing error		

T00-201-05 (3/3)

G: Source of Paper

Code	Description
1	right front deck
2	left front deck
3	cassette 3
4	cassette 4
5	not used
6	not used
7	side paper deck
8	manual feed tray
9	duplexing unit

T00-201-06

T00-201-05 (2/3)

COPIER>DISPLAY>ERR
<ERR>

Indicates the error data.

Display	I/O	Adjust	Function	Option	Test	Counter
< ERR >		< 1/7 >		< READY >		
AA	BBBB	CCCC	DDDD	EEEE	FFff	G HH
AA	BBBB	CCCC	DDDD	EEEE	FFff	G HH
AA	BBBB	CCCC	DDDD	EEEE	FFff	G HH
AA	BBBB	CCCC	DDDD	EEEE	FFff	G HH
AA	BBBB	CCCC	DDDD	EEEE	FFff	G HH
AA	BBBB	CCCC	DDDD	EEEE	FFff	G HH
AA	BBBB	CCCC	DDDD	EEEE	FFff	G HH
AA	BBBB	CCCC	DDDD	EEEE	FFff	G HH
		←		→		

F00-201-03

Item	Description	Remarks
AA	Order of errors (higher the number, older the error)	1 to 50 (50 max.)
BBBB	Date of error	Month, day (2 digits each)
CCCC	Time of error	24-hr notation
DDDD	Time of recovery	24-hr notation (if no recovery, FFFF)
EEEE	Error code	See the chapter on error code.
FFff	Detail code	If none, '00000'.
G	Location	0: copier/main controller 1: feeder 2: finisher 3: not used 4: reader 5: printer 6: PDL
HH	not used	

<HV-STS>

Indicates the readings of the voltage and current systems.

PRIMARY	Indicates the level of current of primary charging. (μA)
PRI-GRID	Indicates the grid voltage of primary charging. (V)
PRE-TR	Indicates the level of current of pre-transfer charging. (μA)
TR	Indicates the level of current of transfer charging. (μA)
SP	Indicates the level of current of separation charging. (μA)
BIAS	Indicates the level of developing bias. (V)

COPIER>DISPLAY>DPOT
<DPOT>

Indicates the photosensitive drum surface potential control data.

DPOT-K	Indicates the surface potential of the photosensitive drum. (V)
VL1T	Indicates the target value for the light-area potential (VL1) for the copier. (V)
VL1M	Indicates the reading of the light-area potential (VL1) for the copier. (V) (reference optimum: VL1T \pm 6 V)
VDT	Indicates the target value of the dark-area potential (VD) for the copier. (V)
VDM	Indicates the reading of the dark-area potential (VD) for the copier. (V) (reference optimum: VDT \pm 6 V)
VDM-P	Indicates the reading of the dark-area potential (VD) for printer (PDL) images. (V) (reference optimum: VDT-P \pm 6 V)
VDT-P	Indicates the target value for the dark-area potential (VD) for printer (PDL) images. (V)

<SENSOR>

Indicates the state of the sensor.

DOC-SZ	Indicates the original size detected by the original size sensor.
DOC-SZ1	Indicates the sensor output detected by the original size sensor 1.
DOC-SZ2	Indicates the sensor output detected by the original size sensor 2.
DOC-SZ3	Indicates the sensor output detected by the original size sensor 3.
DOC-SZ4	Indicates the sensor output detected by the original size sensor 4.

<MISC>

Indicates other states.

FL-LIFE	Indicates the duty ratio of when the scanning lamp is ON. (%)
STM-P-L	Indicates the lamp stop position for stream reading mode (large size). (0 to 6)
STM-P-S	Indicates the lamp stop position for stream reading mode (small size) (0 to 6)
SCAN-LMP	Indicates the reading of the counter (the number of times the scanning lamp has gone ON).

COPIER>DISPLAY>ALARM-2
 <ALARM-2>

Indicates the alarm data.

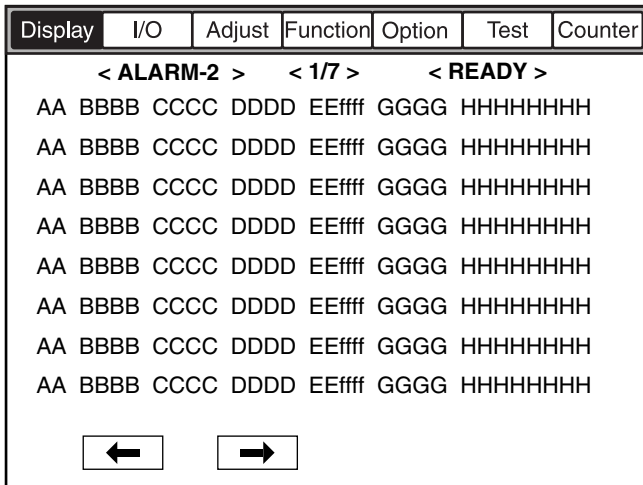

F00-201-04

Item	Description	Remarks
AA	Order of alarms (the higher, the older)	1 to 50 (50 max.)
BBBB	Date of alarm	Month, day (2 digits each)
CCCC	Time of alarm	24-hr notation
DDDD	Time of alarm recovery	24-hr notation (if no recovery, FFFF)
EE	Location code	T00-201-07
ffff	Alarm code	T00-201-07
GGGG	Detail code	
HHHHHHHH	Total counter reading at time of alarm	

List of Alarm Codes

EE	Location code	ffff	Code
00	error code	0804	system fan alarm (detail code: 00004)
02	reader assembly (scanner)	0003	dust detection small 1
		0004	dust detection small 2
		0005	dust detection small 3
		0006	dust detection small 4
		0007	dust detection small 5
		0008	dust detection small 6
		0009	dust detection small 7
		0010	dust detection large 1
		0011	dust detection large 2
		0012	dust detection large 3
		0013	dust detection large 4
		0014	dust detection large 5
		0015	dust detection large 6
		0016	dust detection large 7
		0017	small position stream reading prohibit
		0018	large position stream reading prohibit
		0019	scanner lamp intensity low
04	pickup/feeding system	0001	right deck lifter alarm
		0002	left deck lifer alarm
		0003	cassette 3 lifter alarm
		0004	cassette 4 lifter alarm
		0007	manual feed tray lifter alarm
		0008	side paper deck lifter alarm
		0011	right deck retry alarm
		0012	left deck retry alarm
		0013	cassette 3 retry alarm
		0014	cassette 4 retry alarm
		0017	manual feed retry alarm
		0018	side paper deck retry alarm
30	high-voltage system	0001	primary charging assembly leakage
		0002	transfer charging assembly leakage
		0003	separation charging assembly leakage
32	potential control system	0001	potential control VD alarm
		0002	potential control VL alarm

T00-201-07 (1/2)

SERVICE MODE

COPIER>DISPLAY>ALARM-2

EE	Location	fff	Code
33	fan system	0001	delivery assembly curl-reducing fan alarm
		0005	scanner motor fan alarm
		0006	developing fan alarm
		0007	delivery adhesion prevention fan alarm
		0009	duplex feeding fan alarm
		0010	stream reading fan alarm
61	sorter/finisher stapler system	0001	staple absent
62	saddle stitcher system	0001	stitch staple absent
65	sorter/finisher puncher system	0001	punch waste case full

T00-201-07 (2/2)

2.2 I/O

The following shows the Input/Output screen (COPIER>I/O):

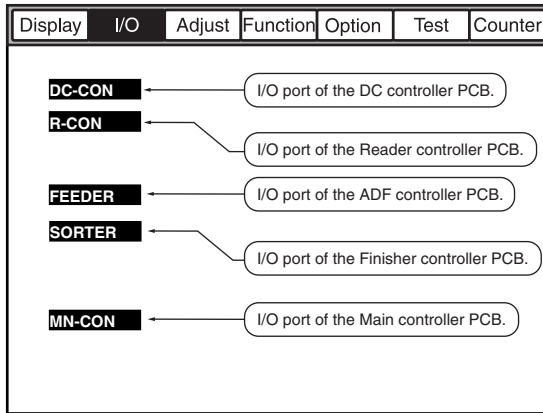

F00-202-01

Guide to the Screen

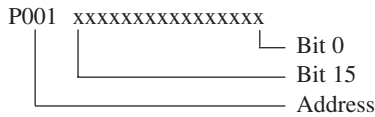

COPIER>I/O>DC-CON
DC-CON

Indicates the input/output ports of the DC controller PCB.

<DC-CON (1/10)>

Address	Bit	Description	Notation	Remarks
P001	0	laser motor cooling fan stop detection signal	FM1	1: stop
	1	fixing heat discharge fan stop detection signal	FM2	1: stop
	2	laser scanner fan stop detection signal	FM3	1: stop
	3	laser drive cooling fan stop detection signal	FM5	1: stop
	4	curl-reducing fan stop detection signal	FM6	1: stop
	5	not used		
	6	drum fan stop detection signal	FM8	1: stop
	7	pre-transfer charging assembly fan stop	FM10	1: stop
	8	power supply cooling fan 1 stop detection signal	FM11	1: stop
	9	power supply cooling fan 2 stop detection signal	FM12	1: stop
	10	separation fan stop detection signal	FM13	1: stop
	11	not used		
	12	delivery adhesion prevention fan stop detection signal		
	13	developing fan stop detection signal	FM15	1: stop
	14	not used		
15	not used			
P002	0	not used		
	1	duplex reversal sensor	PS12	1: paper present
	2	duplex outlet sensor	PS61	1: paper present
	3	pre-confluence sensor	PS14	1: paper present
	4	post-confluence sensor	PS15	1: paper present
	5	image write start sensor	PS60	1: paper present
	6	not used		
	7	not used		
	8	not used		
	9	not used		
	10	not used		
	11	not used		
	12	not used		
	13	DDI		
	14	DDI		
15	DDI			
P003	0	inside hopper toner sensor	TS1	0: toner absent
	1	inside hopper toner lower limit sensor	TS2	0: toner absent

<DC-CON (2/10)>

Address	Bit	Description	Notation	Remarks
	2	inside developing assembly toner sensor	TS3	0: toner absent
	3	fixing web length sensor	PS7	1: web absent
	4	fixing web length warning sensor	PS8	1: web absent pre-caution
	5	cartridge detection	MSW1	0: present
	6	waste toner clog detection	MSW2	0: clogged
	7	waste toner case full sensor	PS19	1: toner case full
	8	not used		
	9	not used		
	10	not used		
	11	not used		
	12	not used		
	13	not used		
	14	not used		
	15	not used		
P004	0	right deck lifter sensor	PS21	1: paper present
	1	left deck lifter sensor	PS31	1: paper present
	2	cassette 3 lifter sensor	PS38	1: paper present
	3	cassette 4 lifter sensor	PS43	1: paper present
	4	right deck paper level middle sensor	PS51	1: paper present
	5	right deck paper level high sensor	PS52	1: paper present
	6	left deck paper level middle sensor	PS54	1: paper present
	7	left deck paper level high sensor	PS55	1: paper present
	8	right deck paper sensor	PS22	1: paper present
	9	left deck paper sensor	PS32	1: paper present
	10	cassette 3 paper sensor	PS39	1: paper present
	11	cassette 4 paper sensor	PS44	1: paper present
	12	manual feed tray paper sensor	PS17	1: paper present
	13	finisher connector		0: connected
	14	right deck limit sensor	PS24	1: limit
	15	left deck limit sensor	PS34	1: limit
P005	0	cassette 3 paper length sensor	SV1	
	1	cassette 3 paper length sensor	SV1	
	2	cassette 4 paper length sensor	SV2	
	3	cassette 4 paper length sensor	SV2	
	4	right deck open/closed sensor	PS23	1: closed
	5	left deck open/closed sensor	PS33	1: closed
	6	cassette 3 open/closed sensor	PS40	1: closed
	7	cassette 4 open/closed sensor	PS45	1: closed

SERVICE MODE

COPIER>I/O>DC-CON
<DC-CON (3/10)>

Address	Bit	Description	Notation	Remarks
	8	right upper cover open/closed sensor	PS58	1: closed
	9	right lower cover open/closed sensor	PS48	1: closed
	10	manual feed tray cover open/closed sensor	PS56	1: closed
	11	front cover open/closed detection	MSW7	0: closed
	12	through path tray attached/detached sensor	PS59	1: closed
	13	through path tray in/out detection		0: attached
	14	fixing feeder unit release lever sensor	PS28	1: released
	15	BD error detection		1: error
P006	0	drum motor lock detection	M0	0: low speed
	1	laser scanner motor lock detection	M4	0: low speed
	2	fixing motor lock detection	M3	0: low speed
	3	primary charging error detection	PCB11	1: error
	4	transfer charging error detection	PCB11	1: error
	5	separation/pre-transfer charging error detection	PCB11	1: error
	6	inside hopper toner feed motor error detection		1: error (E020)
	7	inside cartridge toner feed motor error detection		1: error (E025)
	8	not used		
	9	separation heat discharge fan stop detection		1: stop
	10	not used		
	11	duplex feed fan stop detection		1: stop
	12	not used		
	13	AC relay shut-off open circuit detection		1: error
	14	overcurrent notice (24 V)	PCB14	1: overcurrent
	15	overcurrent notice (38 V)	PCB14	1: overcurrent
P007	0	primary charging wire cleaner drive	M8	1: move to rear
	1	primary charging wire cleaner drive	M8	1: move to front
	2	pre-transfer charging wire cleaner drive	M7	1: move to front
	3	pre-transfer charging wire cleaner drive	M7	1: move to rear
	4	transfer/separation charging wire cleaner drive	M9	1: move to rear
	5	transfer/separation charging wire cleaner drive	M9	1: move to front
	6	not used		
	7	not used		
	8	drum motor drive	M0	0: ON
	9	main motor drive	M1	0: ON
	10	pickup motor drive	M2	0: ON
	11	fixing motor drive	M3	0: ON
	12	laser scanner motor drive	M4	0: ON
	13	cartridge motor drive	M6	1: ON

<DC-CON (4/10)>

Address	Bit	Description	Notation	Remarks
	14	hopper motor drive	M18	1: ON
	15	laser scanner motor switch-over	M4	0: high-speed
P008	0	fixing main heater		1: ON
	1	fixing sub heater		1: ON
	2	cassette heater		0: ON
	3	drum heater		1: ON
	4	drum heater full wave/half wave		0: half-wave
	5	separation heat discharge fan full wave	FM20	0: current up
	6	not used		
	7	separation heat discharge fan half speed	FM20	0: stop
	8	laser motor cooling fan full speed	FM1	1: ON
	9	laser motor cooling fan half speed	FM1	1: ON
	10	laser scanner fan full speed	FM3	1: ON
	11	laser scanner fan half speed	FM3	1: ON
	12	pre-transfer charging assembly fan full speed	FM10	1: ON
	13	pre-transfer charging assembly fan half speed	FM10	1: ON
	14	laser scanner motor cooling fan full speed	FM14	1: ON
	15	duplex feeding fan full speed	FM19	1: ON
P009	0	not used		
	1	not used		
	2	separation fan full speed	FM13	1: ON
	3	not used		
	4	curl-reducing fan full speed	FM6	1: ON
	5	developing fan full speed	FM15	1: ON
	6	developing fan half speed	FM15	1: ON
	7	not used		
	8	fixing heat discharge fan full speed	FM2	1: ON
	9	fixing heat discharge fan half speed	FM2	1: ON
	10	not used		
	11	delivery adhesion prevention fan full speed	FM17	1: ON
	12	drum fan full speed	FM8	1: ON
	13	drum fan half speed	FM8	1: ON
	14	power supply fan full speed	FM11/12	1: ON
	15	power supply fan half speed	FM11/12	1: ON
P010	0	right deck pickup sensor	PS20	1: paper present
	1	left deck pickup sensor	PS25	1: paper present
	2	cassette 3 pickup sensor	PS37	1: paper present
	3	cassette 4 pickup sensor	PS42	1: paper present

SERVICE MODE

COPIER>I/O>DC-CON
<DC-CON (5/10)>

Address	Bit	Description	Notation	Remarks
	4	vertical path 1 paper sensor	PS47	1: paper present
	5	vertical path 2 paper sensor	PS49	1: paper present
	6	vertical path 3 paper sensor	PS41	1: paper present
	7	vertical path 4 paper sensor	PS46	1: paper present
	8	right deck feed sensor	PS27	1: paper present
	9	left deck feed sensor	PS26	1: paper present
	10	manual feed sensor	PS35	1: paper present
	11	registration paper sensor	PS5	1: paper present
	12	internal delivery sensor	PS9	1: paper present
	13	external delivery sensor	PS10	1: paper present
	14	fixing feeder unit outlet sensor	PS11	1: paper present
	15	fixing claw jam sensor	PS6	1: paper present
P011	0	not used		
	1	right deck pickup clutch	CL10	1: ON
	2	left deck pickup clutch	CL11	1: ON
	3	cassette 3 pickup clutch	CL12	1: ON
	4	cassette 4 pickup clutch	CL14	1: ON
	5	vertical path 1 clutch	CL8	1: ON
	6	vertical path 2 clutch	CL9	1: ON
	7	vertical path 3 clutch	CL13	1: ON
P012	0	not used		
	1	vertical path 4 clutch	CL15	1: ON
	2	manual feed tray pickup clutch	CL7	1: ON
	3	manual feed tray feed clutch	CL18	1: ON
	4	pre-registration clutch	CL5	1: ON
	5	left deck feed clutch	CL19	1: ON
	6	lower feed middle clutch	CL16	1: ON
	7	lower feed right clutch	CL17	1: ON
P013	0	not used		
	1	not used		
	2	speed switch-over delivery clutch		
	3	inside hopper magnet roller drive clutch	CL1	1: ON
	4	developing cylinder clutch	CL4	1: ON
	5	developing cylinder deceleration clutch	CL20	1: ON
	6	vibration motor 1		1: ON
	7	vibration motor 2		1: ON
P014	0	not used		
	1	right deck pickup solenoid	SL7	1: ON

<DC-CON (6/10)>

Address	Bit	Description	Notation	Remarks
	2	left deck pickup solenoid	SL8	1: ON
	3	cassette 3 pickup solenoid	SL9	1: ON
	4	cassette 4 pickup solenoid	SL10	1: ON
	5	manual feed pickup latch solenoid (return)	SL6	1: ON
	6	manual feed pickup latch solenoid (draw)	SL6	1: ON
	7	delivery flapper solenoid	SL3	1: ON
P015	0	not used		
	1	reversing flapper solenoid	SL11	1: ON
	2	fixing web solenoid	SL2	1: ON
	3	fixing feeder unit lock solenoid (return)	SL4	0: ON
	4	fixing feeder unit lock solenoid (draw)	SL4	1: ON
	5	not used		
	6	not used		
	7	not used		
P016	0	not used		
	1	pre-exposure lamp	LED1	1: ON
	2	potential sensor	PCB19	1: ON
	3	HVT DC component	HVT	0: high-voltage output ON
	4	HVT developing AC component	HVT	0: ON
	5	HVT pre-transfer AC/separation AC component	HVT	0: ON
	6	paper feed guide bias	PCB11	0: ON
	7	paper feed guide bias switch-over	PCB11	0: 200V, 1: 600V
P017	0	not used		
	1	not used		
	2	not used		
	3	not used		
	4	not used		
	5	not used		
	6	duplex reversal motor ON/OFF		0: ON
	7	duplex reversal motor current switch-over		1: excited
P018	0	not used		
	1	not used		
	2	not used		
	3	not used		
	4	not used		
	5	not used		
	6	duplex feed motor (right/let) ON/OFF		0: ON
	7	duplex feed motor current switch-over		1: excited

SERVICE MODE

COPIER>I/O>DC-CON
<DC-CON (7/10)>

Address	Bit	Description	Notation	Remarks
P019	0	not used		
	1	not used		
	2	not used		
	3	not used		
	4	not used		
	5	not used		
	6	horizontal registration motor ON/OFF		0: ON
	7	horizontal registration motor switch-over		1: excited
P020	0	not used		
	1	not used		
	2	not used		
	3	not used		
	4	not used		
	5	not used		
	6	not used		
	7	not used		
P021	0	not used		
	1	not used		
	2	not used		
	3	not used		
	4	not used		
	5	not used		
	6	waste toner case full detection reset		0: reset
	7	shut off	SW1	1: shut off
P022	0	not used		
	1	not used		
	2	DDI spare		
	3	DDI spare		
	4	printer power ready		L: READY, H: Not READY
	5	printer command reception ready		L: ready
	6	not used		
	7	not used		
P023	0	not used		
	1	not used		
	2	right deck lifer	PS21	: ON
	3	left deck lifer	PS31	: ON
	4	cassette 3 lifer	PS38	: ON
	5	cassette 4 lifer	PS43	: ON
	6	not used		
	7	not used		

<DC-CON (8/10)>

Address	Bit	Description	Notation	Remarks
P024	0	not used		
	1	not used		
	2	not used		H: 5V drive, L: 12V drive
	3	not used		
	4	not used		
	5	not used		
	6	not used		
	7	not used		
P025	0	not used		
	1	not used		
	2	relay ON signal state detection		L: relay ON, H: relay OFF
	3	not used		
	4	not used		
	5	not used		
	6	not used		
	7	horizontal registration sensor		H: detected
P026	0	Paper Deck LED		
	1	Paper Deck pickup roller release solenoid		
	2	Paper Deck drawing clutch		
	3	Paper Deck pickup clutch		
	4	Paper Deck pickup motor		
	5	Paper Deck lifter motor		
	6	Paper Deck lifter motor up/down		
	7	Paper Deck open solenoid		
	8	Paper Deck chip select		(H: CL, etc., L: sensor)
	9	Paper Deck latch IC control		(ON only at power-on)
	10	Paper Deck sensor switch-over		(L: pickup, H: draw)
	11	Paper Deck sensor LED		(H: forced OFF, L: ON)
	12	Paper Deck speed switch-over 1		
	13	Paper Deck speed switch-over 2		
14	not used			
P027	0	Paper Deck open switch		L: OPEN
	1	Paper Deck paper present		H: present
	2	Paper Deck pickup position sensor		H: ON
	3	Paper Deck pickup sensor ON		H: ON

SERVICE MODE

COPIER>I/O>DC-CON
<DC-CON (9/10)>

Address	Bit	Description	Notation	Remarks
	4	Paper Deck draw sensor ON		H: ON
	5	Paper Deck feed solenoid ON		H: ON
	6	Paper Deck motor lock detection		H: detected
	7	Paper Deck paper supply position sensor		H: ON
	8	Paper Deck paper level detection		H: detected
	9	Paper Deck lifter lower limit detection		H: detected
	10	Paper Deck connection to copier detection		H: set
	11	Paper Deck closed		H: closed
	12	Paper Deck lifter motor overcurrent detection		H: detected
	13	not used		
	14	Paper Deck connection detection		(H: detected)
	15	Paper Deck connection detection		(L: detected)
P028	0	not used		
	1	not used		
	2	not used		
	3	not used		
	4	not used		
	5	not used		
	6	not used		
	7	not used		
	8	not used		
	9	not used		
	10	not used		
	11	not used		
	12	not used		
	13	not used		
	14	not used		
	15	not used		
P029	0	not used		
	1	not used		
	2	not used		
	3	not used		
	4	not used		
	5	not used		
	6	not used		
	7	not used		
P030	0	sub SSR error		H: short circuit
	1	main SSR error	E004	H: short circuit
	2	fixing thermistor 2 error detection		H: error
	3	fixing thermistor 1 error detection	B001	H: error

<DC-CON (10/10)>

Address	Bit	Description	Notation	Remarks
	4	fixing thermistor 2 open circuit detection		H: open circuit
	5	fixing thermistor 1 open circuit detection		H: open circuit
	6	fixing motor zero-cross error		H: error
	7	not used		
	8	open by sub SSR		H: open
	9	open by main SSR		H: open
	10	open by fixing thermistor 2 error		H: open
	11	open by fixing thermistor 1 error		H: open
	12	open by fixing thermistor 2 open circuit		H: open
	13	open by fixing thermistor 1 open circuit		H: open
	14	not used		
	15	not used		

R-CON

Indicates the input/output ports of the reader controller PCB.

<R-CON (1/3)>

Address	Bit	Description	Notation	Remarks
P001	0	original size detection 1		0: detected
	1	original size detection 2		0: detected
	2	original size detection 3		0: detected
	3	original size detection 4		0: detected
	4	copyboard open/closed detection		1: closed
	5	not used		
	6	not used		
P002	0	fluorescent lamp absent		1: absent
	1	fluorescent lamp ON detection		1: ON, 0: OFF
	2	not used		
	3	not used		
	4	scanner motor cooling fan		1: stop
	5	stream reading fan		1: stop
	6	inverter fan		1: stop
P003	0	original orientation detection PCB power detection		0: connected
	1	original orientation detection PCB busy detection		0: busy

SERVICE MODE

COPIER>I/O>R-CON
<R-CON (2/3)>

Address	Bit	Description	Notation	Remarks
	2	original orientation detection PCB error detection		0: error
	3	not used		
	4	not used		
	5	not used		
	6	not used		
	7	CCD/AP type detection		
P004	0	inverter fan full speed		1: ON (24V)
	1	inverter fan half speed		1: ON (12V)
	2	scanner motor cooling fan full speed		1: ON (24V)
	3	scanner motor cooling fan half speed		1: ON (12V)
	4	stream reading fan ON		1: ON (24V)
	5	not used		
	6	image leading select		1: copier, 0: ADF
	7	size detection on/off		1: ON
P005	0	scanner motor D0		
	1	scanner motor D1		
	2	scanner motor D2		
	3	scanner motor D3		
	4	scanner motor CDWN0		
	5	scanner motor CDWN1		
	6	scanner motor CDWN2		
	7	not used		
P006	0	scanner motor CW/CCW		1: CW, 0: CCW
	1	scanner motor OFF		0: OFF
	2	not used		
	3	not used		
	4	fluorescent lamp pre-heat ON		0: ON
	5	fluorescent lamp heater ON		0: ON
	6	fluorescent lamp ON		0: ON
	7	not used		
P007	0	CCD/AP ON/OFF		1: stop, 0: operate
	1	CCD/AP sync clock		
	2	CCD/AP sync data		
	3	CCD/AP RING2 load signal		
	4	CCD/AP F-AP load signal		
	5	CCD/AP B-AP load signal		
	6	not used		
	7	not used		

<R-CON (3/3)>

Address	Bit	Description	Notation	Remarks
P008	0	not used		
	1	not used		
	2	not used		
	3	not used		
	4	not used		
	5	not used		
	6	not used		
	7	not used		

FEEDER

Indicates the input/output ports of the ADF controller PCB.



The indication will be '0' while the machine is in operation (reading an original).

<FEEDER (1/4)>

Address	Bit	Description	Notation	Remarks
IO-P01	0	pre-reversal solenoid	SL3	1: ON
	1	belt motor cooling fan		0: ON
	2	reversal solenoid	SL1	1: ON
	3	delivery solenoid (position 1)	SL4	1: ON
	4	delivery solenoid (position 2)	SL4	1: ON
	5	stopper plate solenoid (position 1)	SL2	1: ON
	6	stopper plate solenoid (position 2)	SL2	1: ON
	7	solenoid timer		0: ON
IO-P02	0	not used		
	1	not used		
	2	not used		
	3	not used		
	4	pickup roller home position	PI7	1: HP
	5	pickup roller height sensor 2	PI9	1: original present
	6	pickup roller height sensor 1	PI8	1: original present
	7	pre-reversal sensor	PI4	1: original present
IO-P03	0	not used		
	1	original detection sensor LED		0: emit
	2	not used		
	3	not used		
	4	not used		

SERVICE MODE

COPIER>I/O>FEEDER
<FEEDER (2/4)>

Address	Bit	Description	Notation	Remarks
	5	not used		
	6	not used		
	7	not used		
IO-P04	0	original sensor	S6	0: original present
	1	original trailing edge sensor		1: original present
	2	last original front sensor	S8	1: original present
	3	not used		
	4	separation motor	M4	
	5	delivery motor	M5	
	6	24V logic down detection		
	7	24V power down detection		
IO-P05	0	separation sensor	S4	0: original present
	1	separation sheet-to-sheet clock		during outputs, repeats '0' and '1'
	2	belt motor clock detection	PI1	during outputs, repeats '0' and '1'
	3	registration roller rear paper sensor	S3	0: original present
	4	manual feed registration roller paper sensor	S9	1: original present
	5	not used		
	6	not used		
	7	not used		
IO-P06	0	serial data output		1: transmit
	1	D/A load path		1: transmit
	2	EEPROM serial input		1: receive
	3	EEPROM chip select		0: select EEPROM
	4	serial reference clock		during outputs, repeats '0' and '1'
	5	separation motor clock detection	PI2	during outputs, repeats '0' and '1'
	6	not used		
	7	not used		
IO-P07	0	belt motor mode 1	M2	at all times, '0'
	1	belt motor mode 2	M2	at all times, '0'
	2	belt motor reference clock	M2	during outputs, repeats '0' and '1'
	3	belt motor CW/CCW	M2	0: delivery direction
	4	separation motor PWM	M4	during outputs, repeats '0' and '1'
	5	reversal motor phase B	M1	during outputs, repeats '0' and '1'

COPIER>I/O>FEEDER

<FEEDER (3/4)>

Address	Bit	Description	Notation	Remarks
	6	delivery motor PWM	M5	during outputs, repeats '0' and '1'
	7	reversal motor phase A	M1	during outputs, repeats '0' and '1'
IO-P08	0	image leading edge signal		1: leading edge
	1	pre-registration roller paper sensor	S2	0: original present
	2	separation motor reference clock		during outputs, repeats '0' and '1'
	3	delivery motor clock detection	PI11	during outputs, repeats '0' and '1'
	4	pickup motor phase A		during outputs, repeats '0' and '1'
	5	pickup motor phase B		during outputs, repeats '0' and '1'
	6	pickup motor hold		1: output present
	7	AD trigger		1: output present
IO-P09	0	not used		
	1	separation clutch	CL	1: ON
	2	skew sensor	S5	1: original present
	3	original delivery sensor	PI13	1: original present
	4	manual feed set sensor	PI12	1: original present
	5	not used		
	6	reversal sensor	S1	1: original present
	7	registration roller rotation detection	PI5	during outputs, repeats '0' and '1'
IO-P10	0	DIP switch (DIPSW1)		0: ON
	1	signal DIP switch (DIPSW2) signal		0: ON
	2	DIP switch (DIPSW3) signal		0: ON
	3	DIP switch (DIPSW4) signal		0: ON
	4	DIP switch (DIPSW5) signal		0: ON
	5	DIP switch (DIPSW6) signal		0: ON
	6	upper cover front sensor (front)		1: closed
	7	upper cover rear sensor (rear)		1: closed
IO-P11	0	7-segment LED0		0: ON
	1	7-segment LED1		0: ON
	2	7-segment LED2		0: ON
	3	7-segment LED3		0: ON
	4	7-segment LED4		0: ON
	5	7-segment LED5		0: ON
	6	7-segment LED6		0: ON
	7	ADF open/closed sensor		1: closed

SERVICE MODE

COPIER>I/O>FEEDER

<FEEDER (4/4)>

Address	Bit	Description	Notation	Remarks
IO-P12	0	original width detecting switch 0		1: ON
	1	original width detection switch 1		1: ON
	2	original width detecting switch 2		1: ON
	3	original width detecting switch 3		1: ON
	4	original width detecting switch 4		1: ON
	5	push switch 1		0: ON
	6	push switch 2		0: ON
	7	push switch 3		0: ON
AD-P01		tray volume		(hereafter, analog ports)
AD-P02		separation rear sensor analog input		
AD-P03		read sensor analog input		
AD-P04		delivery reversal sensor analog input		
AD-P05		not used		
AD-P06		not used		
AD-P07		not used		
AD-P08		not used		
DA-P01		reversal motor		(hereafter, analog ports)
DA-P02		belt motor		
DA-P03		original sensor adjustment		
DA-P04		trailing edge sensor adjustment		
DA-P05		separation rear sensor adjustment		
DA-P06		skew sensor adjustment		
DA-P07		pre-registration-roller sensor adjustment		
DA-P08		post-registration-roller sensor adjustment		
DA-P09		reversal sensor adjustment		
DA-P10		manual feed registration sensor adjustment		
DA-P11		pre-cycle end sensor adjustment		
DA-P12		separation motor		

SORTER

Indicates the input/output ports of the finisher controller PCB.

<SORTER (1/12)>

Finisher Block

Address	Bit	Description	Notation	Remarks
P001	0	buffer motor A	M2	during output, repeats '0' and '1'
	1	buffer motor B	M2	during output, repeats '0' and '1'
	2	buffer motor A*	M2	during output, repeats '0' and '1'
	3	buffer motor B*	M2	during output, repeats '0' and '1'
	4	delivery motor A	M3	during output, repeats '0' and '1'
	5	delivery motor B	M3	during output, repeats '0' and '1'
	6	upper path switch-over solenoid	SL2	0: ON
	7	buffer path switch-over solenoid	SL1	1: wrap, 0: release
P002	0	front aligning plate motor B	M4	during output, repeats '0' and '1'
	1	front aligning plate motor A	M4	during output, repeats '0' and '1'
	2	inlet motor brake	M1	1: braking
	3	buffer path rear paper sensor	PI3	1: paper present
	4	rear aligning plate motor B	M5	during output, repeats '0' and '1'
	5	rear aligning plate motor A	M5	during output, repeats '0' and '1'
	6	stack delivery motor clock	M7	during output, repeats '0' and '1'
	7	inlet motor clock	M1	during output, repeats '0' and '1'
P003	0	EEPROM serial output	-	-
	1	slave write serial output	-	-
	2	EEPROM serial output	-	-
	3	slave write serial output	-	-
	4	EEPROM serial clock	-	-
	5	EEPROM load signal	-	-
	6	not used		
7	not used			

SERVICE MODE

COPIER>I/O>SORTER
<SORTER (2/12)>

Address	Bit	Description	Notation	Remarks
P004	0	tray A paper detection	PI20	1: paper present
	1	puncher identification 1	-	-
	2	puncher identification 2	-	-
	3	delivery sensor	PI32	1: paper present
	4	lower path paper sensor	PI4	1: paper present
	5	upper path paper sensor	PI6	1: paper present
	6	inlet path paper sensor	PI2	1: paper present
	7	buffer path paper sensor	PI3	1: paper present
P005	0	delivery motor ON	M3	1: stop, 0: ON
	1	delivery motor current switch-over	M3	1: constant speed, 0: accelerate
	2	inlet motor On	M1	1: OFF, 0: ON
	3	inlet motor CW*/CCW	M1	1: CCW, 0: CW
	4	not used		
	5	not used		
	6	not used		
	7	not used		
P006	0	trimmer connection detected		1: connected
	1	DRAM chip select		0: cs
	2	stapler interference position detection		1: interfere, 0: ready
	3	staple cartridge indication		1: 50 sheets, 0: 100 sheets
	4	punch path sensor	S1	0: paper present
	5	stack delivery motor FG	PI11	during output, repeats '0' and '1'
	6	inserter motor FG*	PI67	during output, repeats '0' and '1'
	7	buffer motor FG*	M2	during output, repeats '0' and '1'
P007	0	not used		
	1	not used		
	2	not used		
	3	not used		
	4	not used		
	5	delivery motor FG*	M3	during output, repeats '0' and '1'
	6	inlet motor FG*	M1	during output, repeats '0' and '1'
	7	fold motor FG*	M71	during output, repeats '0' and '1'

<SORTER (3/12)>

Address	Bit	Description	Notation	Remarks
P008	0	slave write signal		1: normal, 0: write
	1	slave CPU reset		0: reset
	2	master busy signal		0: busy
	3	not used		
	4	not used		
	5	not used		
	6	not used		
	7	not used		
P009	0	handling tray solenoid ON		1: ON, 0: OFF
	1	expander chip select		0: cs
	2	IPC chip select		0: cs
	3	PIO chip select		0: cs
	4	EPROM chip select		0: cs
	5	not used		
	6	not used		
	7	not used		
P010	0	staple absent detection		1: staple absent, 0: staple present
	1	READY detection		1: NO, 0: ready
	2	stack tray approach detection		0: ON
	3	door 24V down detection		1: down
	4	feed path paper detection 1	PI76	1: paper present
	5	feed path paper detection 2	S7	1: paper present
	6	feed path paper detection 3	S8	1: paper present
	7	feed path paper detection 4	PI75	1: paper present
P011	0	inserter cover open/closed detection		1: open
	1	stack wall safety detection		1: error
	2	inserter unit detection		1: absent, 0: present
	3	punch unit detection		1: absent, 0: present
	4	paper folding unit detection		1: absent, 0: present
	5	saddle unit detection		1: absent, 0: present
	6	stapler interference sensor connection detection		1: connected
	7	fan rotation error detection		1: error, 0: normal

SERVICE MODE

COPIER>I/O>SORTER
<SORTER (4/12)>

Address	Bit	Description	Notation	Remarks
P012	0	swing motor high-speed setting	M8	1: ON
	1	swing motor medium speed setting	M8	1: ON
	2	swing motor low speed setting	M8	1: ON
	3	swing motor ON*	M8	1: OFF, 0: ON
	4	power fan ON signal	FM1	1: ON, 0: OFF
	5	buffer motor ON signal	M2	1: OFF, 0: ON
	6	buffer motor current switch-over	M2	1: constant speed, 0: acceleration
	7	trailing edge drop solenoid ON	SL5	0: ON
P013	0	stack delivery motor CW*	M7	1: CCW, 0: CW
	1	stack delivery motor ON*	M7	1: OFF, 0: ON
	2	stack delivery start-up current switch-over		1: up, 0: down
	3	front aligning plate motor ON	M4	1: OFF, 0: ON
	4	rear aligning plate motor ON	M5	1: OFF, 0: ON
	5	tray sub plate motor A		
	6	tray sub plate motor B		
	7	tray sub plate motor ON		1: OFF, 0: ON
P014	0	knurled belt motor phase A	M20	
	1	knurled belt motor phase B	M20	
	2	knurled belt motor ON	M20	1: OFF, 0: ON
	3	paddle motor A	M9	
	4	paddle motor B	M9	
	5	paddle motor ON	M9	1: OFF, 0: ON
	6	folder motor gain switch-over	M71	1: high-speed, 0: low-speed
	7	not used		
P015	0	paddle home position detection	PI14	0: HP
	1	folder set detection	PI71	1: present, 0: absent
	2	inserter open detection	PI66	1: closed, 0: open
	3	front door switch open detection		1: closed, 0: open
	4	folder upper door switch	MSW71	1: closed, 0: open
	5	upper cover open/closed detection	PI72	1: closed, 0: open
	6	fold path residual paper detection 1	PI73	1: present, 0: absent
	7	saddle inlet front path sensor	PI59	1: paper present, 0: paper absent

<SORTER (5/12)>

Address	Bit	Description	Notation	Remarks
P016	0	puncher waste feed motor ON	M16	1: ON
	1	sub tray solenoid ON		
	2	punch power supply ON		1: ON
	3	inlet motor gain adjustment		1: high speed, 0: low speed
	4	power OFF		1: down
	5	saddle path flapper solenoid ON	SL44	0: ON
	6	inserter motor ON	M61	1: OFF, 0: ON
	7	unit identification signal		1: identified
P017	0	inserter separation detection 1	PI62	1: paper present, 0: paper absent
	1	inserter separation detection 2	PI63	1: paper prevent, 0: paper absent
	2	inserter feed detection 3	PI61	1: paper prevent, 0: paper absent
	3	tray B paper detection	PI17	1: paper prevent, 0: paper absent
	4	tray A paper detection	PI20	1: paper prevent, 0: paper absent
	5	swing guide closed detection	PI14	0: closed
	6	swing guide home position detection	PI15	1: HP
	7	handling tray paper detection	PI32	1: paper present, 0: paper absent
P018	0	punch waste case detection	PI26	1: set
	1	punch waste feed motor error detection	PI27	1: normal, 0: error
	2	feed cooling fan error detection	FM2	1: error, 0: normal
	3	knurled belt home position detection	PI31	1: HP
	4	shutter home position sensor		0: HP
	5	rear aligning plate home position sensor	PI8	1: HP
	6	front aligning plate home position sensor	PI7	1: HP
	7	tray sub plate withdraw sensor	PI10	1: HP
P019	0	check switch 1 (for test mode)		0: ON
	1	check switch 2 (for test mode)		0: ON
	2	check switch 3 (for test mode)		0: ON
	3	check switch 4 (for test mode)		0: ON
	4	check switch 5 (for test mode)		0: ON
	5	check switch 6 (for test mode)		0: ON
	6	check switch 7 (for test mode)		0: ON
	7	check switch 8 (for test mode)		0: ON

SERVICE MODE

COPIER>I/O>SORTER

<SORTER (6/12)>

Address	Bit	Description	Notation	Remarks
P020	0	P switch for ENTER		0: ON
	1	P switch for +		0: ON
	2	P switch for -		0: ON
	3	puncher identification		
	4	for adjustment 0		0: ON
	5	for adjustment 1		0: ON
	6	for adjustment 2		0: ON
	7	for adjustment 3		0: ON
P021	0	segment a (dot)		1: ON
	1	segment b (middle)		1: ON
	2	segment c (left upper)		1: ON
	3	segment d (left lower)		1: ON
	4	segment e (lower)		1: ON
	5	segment f (right lower)		1: ON
	6	segment g (right upper)		1: ON
	7	segment dot (upper)		1: ON
P022	0	not used		
	1	inserter motor speed switch-over 1	M61	
	2	inserter motor speed switch-over 2	M61	1: ON
	3	inserter separation sensor	PI61/62	1: paper present, 0: paper absent
	4	inserter paper set sensor	S9	1: paper present, 0: paper absent
	5	inserter pickup solenoid	SL61	1: ON
	6	inserter stopper plate solenoid	SL62	0: ON
	7	inserter separation clutch	CL61	1: ON
P023	0	fold feed motor ON		1: ON
	1	folder inlet solenoid ON		1: ON
	2	decompression solenoid ON		1: ON
	3	B4 fold No. 2 stopper solenoid ON	SL72	1: ON
	4	locking solenoid ON		1: ON
	5	B4 fold No. 1 stopper solenoid ON	SL75	1: ON
	6	fold path residual paper detection 2	PI77	1: paper present
	7	fold path residual paper detection 3	PI74	1: paper present

<SORTER (7/12)>

Address	Bit	Description	Notation	Remarks
P024	0	address bus 8		
	1	address bus 9		
	2	address bus 10		
	3	punch 2/3-hole detection	PI33	1: 3-hole, 0: 2-hole
	4	punch motor home position detection	PI22	1: HP
	5	sample tray position detection 1		1: light-block
	6	sample tray position detection 2		1: light-block
	7	sample tray position detection 3		1: light-block
P025	0	tray B lift motor A	M12	
	1	tray B lift motor B	M12	
	2	tray B lift motor A*	M12	
	3	tary B lift motor B*	M12	
	4	tray A lift motor A	M13	
	5	tray A lift motor B	M13	
	6	tray A lift motor A*	M13	
	7	tray A lift motor B*	M13	
P026	0	stack tray position detection 1		1: light-block
	1	stack tray position detection 2		1: light-block
	2	stack tray position detection 3		1: light-block
	3	stapler home position detection		0: HP
	4	not used		
	5	not used		
	6	not used		
	7	not used		
P027	0	salve busy R		0: busy
	1	stapler shift home position detection	PI16	1: HP
	2	punch home position detection	PI24	
	3	not used		
	4	not used		
	5	not used		
	6	not used		
	7	paper edge sensor slide home position detection	PI23	1: HP

SERVICE MODE

COPIER>I/O>SORTER
<SORTER (8/12)>

Address	Bit	Description	Notation	Remarks
P028	0	waste detection sensor		0: paper waste absent, 1: paper waste present
	1	lower path sensor adjustment		1: normal, 0: error
	2	tray A sensor		1: absent, 0: present
	3	tray B sensor		1: absent, 0: present
	4	tray A paper detection	PI20	1: absent, 0: present
	5	tray A paper detection	PI17	1: absent, 0: present
	6	punch feed path detection	S1	
	7	buffer path sensor	PI3	
P029	0	punch paper edge detection 1	PI21	
	1	punch paper edge detection 2	PI21	
	2	tray B idle rotation detection	PI18	
	3	tray A idle rotation detection	PI19	
	4	punch position detection	PI25	1: rear, 0: front
	5	not used		
	6	not used		
	7	not used		
P030	0	D/A serial output		
	1	flash serial output		
	2	punch motor ON	M18	1: OFF, 0: ON
	3	flash serial input		
	4	D/A serial lock		
	5	not used		
	6	not used		
	7	not used		
P031	0	stapler shift motor ON*	M10	1: retain, 0: drive
	1	D/A load signal		
	2	stapler shift motor A	M10	
	3	stapler shift more B	M10	
	4	stapler shift motor A*	M10	
	5	stapler shift motor B*	M10	
	6	stapler motor CCW*	M11	0: CCW
	7	stapler motor CW*	M11	0: CW

<SORTER (9/12)>

Address	Bit	Description	Notation	Remarks
P032	0	punch motor PWM	M18	
	1	DRAM chip select		
	2	punch slide motor clock	PI34	1: ON, 0: OFF
	3	punch motor	M18	
	4	punch slide motor direction switch-over		1: rear, 0: front
	5	punch motor direction switch-over CW	M18	1: OFF, 0: ON
	6	punch motor direction switch-over CCW	M18	1: OFF, 0: ON
	7	punch slide motor current switch-over		1: constant speed, 0: accelerate
P033	0	stitch motor (rear) CW signal	M46	0: CW
	1	stitch motor (rear) CCW signal	M46	0: CCW
	2	stitch motor (front) CW signal	M47	0: CW
	3	stitcher motor (front) CCW signal	M47	0: CCW
	4	paper fold motor CW drive signal	M42	0: CW
	5	paper fold motor CCW drive signal	M42	0: CCW
	6	No. 1 paper deflect solenoid drive signal	SL41	0: ON
	7	No. 2 paper deflect solenoid drive signal	SL42	0: ON
P034	0	not used		
	1	not used		
	2	not used		
	3	not used		
	4	not used		
	5	feed roller contact drive signal	SL43	1: ON
	6	solenoid timer (full suction) output		0: ON
	7	paper portioning plate motor power	M44	0: ON
P035	0	24V power supply down detection		1: down
	1	paper pushing plate leading edge position	PI56	1: leading edge
	2	delivery detection	PI52	0: paper present
	3	not used		
	4	not used		
	5	not used		
	6	not used		
	7	not used		

SERVICE MODE

COPIER>I/O>SORTER
<SORTER (10/12)>

Address	Bit	Description	Notation	Remarks
P036	0	not used		
	1	not used		
	2	paper pushing plate home position detection	PI55	1: HP
	3	aligning plate home position detection	PI48	0: HP
	4	saddle tray home position detection	PI41	0: HP
	5	not used		
	6	not used		
	7	not used		
P037	0	paper positioning plate home position detection	PI49	0: HP
	1	not used		
	2	inlet cover open detection connector connection	PI51	0: connected
	3	not used		
	4	feed roller phase detection	PI53	1: flag present
	5	aligning plate home position detection connection	PI48	0:HP
	6	not used		
	7	not used		
P038	0	paper positioning plate motor phase A	M44	
	1	paper positioning plate motor phase B	M44	
	2	paper pushing plate motor PWM	M48	
	3	feed motor	M41	0: ON
	4	feed motor phase A	M41	
	5	feed motor phase B	M41	
	6	feed motor reference clock	M41	
	7	paper pushing plate motor CCW	M48	0: CCW
P039	0	alignment motor phase A	M45	
	1	alignment motor phase B	M45	
	2	paper fold motor PWM	M42	
	3	paper pushing plate motor CW	M48	0: CW
	4	guide motor phase A	M43	
	5	guide motor phase B	M43	
	6	guide motor	M43	0: ON
	7	alignment motor	M45	0: ON

<SORTER (11/12)>

Address	Bit	Description	Notation	Remarks
P040	0	No. 2 paper detection	PI61	0: paper present
	1	No. 3 paper detection	PI62	0: paper present
	2	stitching home position detection (rear)	MS32	1: HP
	3	stitching home position detection (front)	MS34	1: HP
	4	paper position plate detection	PI50	0: paper present
	5	No. 1 paper detection	PI60	0: paper present
	6	vertical path paper detection	PI57	0: paper present
	7	not used		
P041	0	aligning plate home position detection connector connection	PI48	1: connected
	1	not used		
	2	outlet cover open detection connector connection	PI46	1: connected
	3	not used		
	4	paper pushing plate leading edge position detection connector connection	PI56	1: connected
	5	paper pushing plate home position detection connector connection	PI55	1: connected
	6	saddle tray paper detection 2	PI43	1: paper present
	7	saddle tray paper detection 3	PI44	1: paper present
P042	0	not used		
	1	LED1 drive		
	2	saddle tray motor phase A	M49	
	3	saddle tray motor phase B	M49	
	4	not used		
	5	not used		
	6	not used		
	7	not used		
P043	0	staple present detection (front)	MS33	0: staple absent
	1	staple present detection (rear)	MS31	0: staple absent
	2	not used		
	3	not used		
	4	outlet over open detection	PI46	0: open
	5	not used		
	6	inlet cover open detection	PI51	0: open
	7	not used		

SERVICE MODE

COPIER>I/O>SORTER
<SORTER (12/12)>

Address	Bit	Description	Notation	Remarks
P044	0	DIPSW1 Bit 8		0: ON
	1	DISPW1 Bit 7		0: ON
	2	DIPSW1 Bit 6		0: ON
	3	DIPSW1 Bit 5		0: ON
	4	DIPSW1 Bit 4		0: ON
	5	DIPSW1 Bit 3		0: ON
	6	DIPSW1 Bit 2		0: ON
	7	DIPSW1 Bit 1		0: ON
P045	AN1	not used		
P046	AN6	not used		
P047	AN7	not used		
P048	DA1	not used		
P049	DA2	not used		
P050	DA3	not used		
P051	DA4	not used		
P052	DA5	not used		
P053	DA6	not used		
P054	DA7	not used		
P055	DA8	not used		
P056	DA9	not used		
P057	DA10	not used		
P058	DA11	not used		
P059	DA12	not used		
P060	AN0	staple present (rear)	MS31	if 92 or higher, staple present
P061	AN1	staple present (front)	MS33	if 92 or higher, staple present
P062	AN2	not used		
P063	AN3	inlet over open detection connector connection	PI51	if 128 or higher, connected
P064	AN4	saddle tray home position detection connector connection	PI41	if 128 or higher, connected
P065	AN5	guide home position detection connector connection	PI54	if 128 or higher, connected
P066	AN6	not used		
P067	AN7	paper pushing plate leading edge detection connector connection	PI56	if 128 or higher, connected

MN-CON

Indicates the input/output port of the main controller PCB.

<MN-CON(1/2)>

Address	Bit	Description	Notation	Remarks
P001	0	not used (fixed to 1)		
	1	not used (fixed to 1)		
	2	not used (fixed to 1)		
	3	not used (fixed to 1)		
P002	0	DDI-S general-purpose input		not used
	1	DDI-S general-purpose input		not used
	2	DDI-S general-purpose input		not used
	3	SPRTST signal, printer start-up signal	SPI	0: reader image start
P003	0	DDI-P general-purpose input		not used
	1	DDI-P general-purpose input		not used
	2	DDI-P general-purpose input		not used
	3	PSCNTST signal (scanner start-up signal)	PPI	0: reader start
P004	0	DDI-S general-purpose output		not used
	1	DDI-S general-purpose output		not used
	2	3.3V emergency power-off signal		0: normal (ON), 1=5W (OFF) sleep mode
	3	SSCNST signal	SP0	not used
P005	0	DDI-P general-purpose output		not used
	1	DDI-P general-purpose output		not used
	2	DDI-P general-purpose output		not used
	3	PPRTST signal	PPO	0: printer image start
P006	0	battery alarm		0: normal, 1: error
	1	parallel EEPROM R/B#		0: busy, 1: ready
	2	flash ROM R/B#		0: busy, 1: ready
	3	serial ROM connection detection		1: connected
	4	operation enable (card reader)		0: enabled
	5	operation enable (coin robot)		0: enabled (not used)
	6	serial EEPROM DO		access port to EEPROM
	7	HD connection detecting	GPI	0: HD present, 1: HD absent
P007	0	battery charge control		0: Enable, 1: Disable
	1	not used		
	2	not used		
	3	not used		
	4	PCI (PDL) soft reset		0: LIPS board forced reset
	5	serial EEPROM CS		for factory adjustment

SERVICE MODE

COPIER>I/O>MN-CON

<MN-CON (2/2)>

Address	Bit	Description	Notation	Remarks
	6	serial EEPROM SCK		for factory adjustment
	7	serial EEPROM DIN		for factory adjustment
	8	pickup count		1: count
	9	delivery count		1: count
	10	coin robot pickup count		1: count (not used)
	11	coin robot delivery count		1: count (not used)
	12	LCD back-light control		1: ON
	13	not used		
	14	parallel EEPROM write protect		0: Write, 1: Protect
	15	not used		
P008	0	not used		
	1	not used		
	2	not used		
	3	color UI detection		0: color UI present
	4	B&W UI detection		0: B&W UI present
	5	BAT board detection		0: present
	6	not used		
	7	not used		

2.3 ADJUST

The following shows the Adjust screen (COPIER>ADJUST):

Display	I/O	Adjust	Function	Option	Test	Counter
LAMP		BLANK				
AE		V-CONT				
ADJ-XY					EXP-LED	
CCD				FEED-ADJ		
LASER		HV-PRI		CST-ADJ		
				HV-TR		
DEVELOP		HV-SP				
DENS						

F00-203-01



A change to any of the items under COPIER>ADJUST becomes valid when the main power switch is turned off and then on again.

COPIER>ADJUST>LAMP>AE
<LAMP>

Use it to adjust the voltage used to turn on the scanning lamp.

L-DATA

Use it to enter the scanning lamp intensity data.

Range of adjustment 0 to 1023

- A higher input value increases the intensity.
- A lower input value decreases the intensity.

If the output shows faulty images after execution of the following, enter the values indicated on the service sheet: COPIER>FUNCTION>CCD>CCD-ADJ.

<AE>

Use it to make AE adjustments.

AE-TBL

Use it to adjust the density of the text for image density adjustment.

Range of adjustment 1 to 9; default: 5

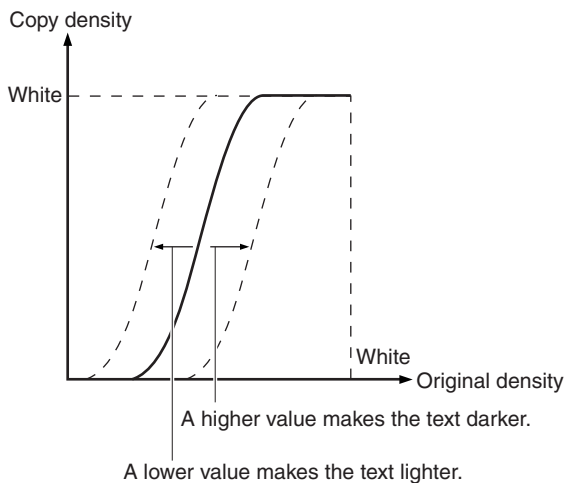

F00-203-02

<ADJ-XY>

Use it to adjust the image read start position.

If you have replaced the reader controller PCB or cleared the RAM of the reader controller PCB, enter the values indicated on the service sheet.

ADJ-X

Range of adjustment

Use it to adjust the image read start position (main scanning direction).

0 to 2970 (unit: 0.1 mm)



Be sure to execute it before adjusting the margin.

Be sure not to use it to create a margin.

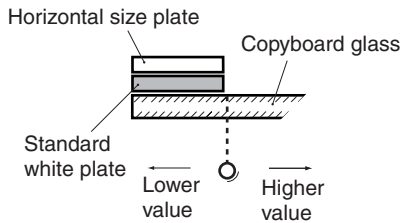

F00-203-03

ADJ-Y

Range of adjustment

Use it to adjust the image read start position (sub scanning direction).

0 to 1000 (unit: 0.1 mm)

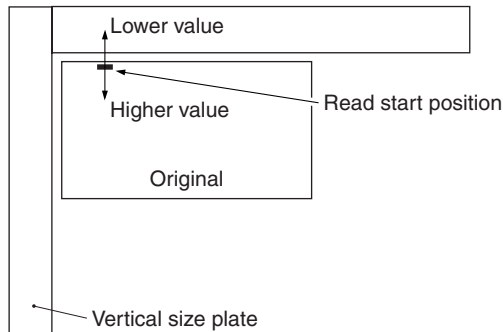

F00-203-04

COPIER>ADJUST>ADJ-XY

ADJ-S

Use it to adjust the scanner home position.

Range of adjustment 0 to 4 (unit: 0.1 mm)

 If dirt exists on the copyboard glass, use it so that the machine reads the standard white plate while avoiding the area.

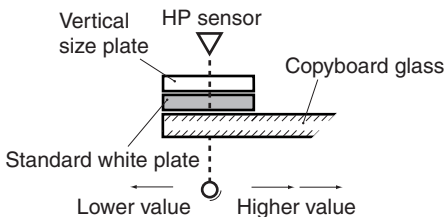

F00-203-05

ADJ-Y-DF

Use it to adjust the read start position in main scanning direction (ADF horizontal registration adjustment).

Range of adjustment 0 to 1000 (unit: 0.1 mm)

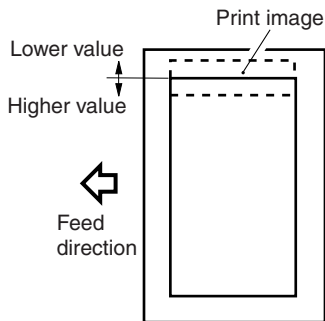

F00-203-06

<CCD>

Use it to make CCD-related (shading) adjustments.

If the output shows faulty images after execution of the following, enter the values indicated on the service sheet: COPIER>FUNCTION>CCD>CCD-ADJ, LUT-ADJ (LUT-ADJ2).

SH-TRGT	Use it to enter the white level target value for shading correction. 1 to 2043
GAIN-E-R	Use it to enter the gain value for the last half even-numbered pixels of the CCD. 0 to 1023
GAIN-O-R	Use it to enter the gain value of the last half odd-numbered pixels of the CCD. 0 to 1023
GAIN-E-F	Use it to enter the gain value for the first half even-numbered pixels of the CCD. 0 to 1023
GAIN-O-F	Use it to enter the gain value for the first half odd-numbered pixels of the CCD. 0 to 1023
OFST-E-R	Use it to enter the offset value for the last half even-numbered pixels of the CCD. 0 to 1023
OFST-O-R	Use it to enter the offset value for the last half odd-numbered pixels of the CCD. 0 to 1023
OFST-E-F	Use it to enter the offset value for the first half even-numbered pixels of the CCD. 0 to 1023
OFST-O-F	Use it to enter the offset value for the first half odd-numbered pixels of the CCD. 0 to 1023
LUT-O-R1	Use it to enter the link correction data value for the last half odd-numbered pixels of the CCD. 0 to 1023
LUT-O-R2	Use it to enter the link correction data value for the last half odd-numbered pixels of the CCD. 0 to 1023

COPIER>ADJUST>CCD



LUT-O-R3	Use it to enter the link correction data value for the last half odd-numbered pixels of the CCD. 0 to 1023
LUT-O-R4	Use it to enter the link correction data value for the last half odd-numbered pixels of the CCD. 0 to 1023
LUT-O-R5	Use it to enter the link correction data value for the last half odd-numbered pixels of the CCD. 0 to 1023
LUT-E-R1	Use it to enter the link correction data value for the last half even-numbered pixels of the CCD. 0 to 1023
LUT-E-R2	Use it to enter the link correction data value for the last half even-numbered pixels of the CCD. 0 to 1023
LUT-E-R3	Use it to enter the link correction data value for the last half even-numbered pixels of the CCD. 0 to 1023
LUT-E-R4	Use it to enter the link correction data value for the last half even-numbered pixels of the CCD. 0 to 1023
LUT-E-R5	Use it to enter the link correction data value of the last even-numbered pixels of the CCD. 0 to 1023
LUT-O-F1	Use it to enter the link correction data value for the first half odd-numbered pixels of the CCD. 0 to 1023
LUT-O-F2	Use it to enter the link correction data value for the first half odd-numbered pixels of the CCD. 0 to 1023
LUT-O-F3	Use it to enter the link correction data value for the first half odd-numbered pixels of the CCD. 0 to 1023
LUT-O-F4	Use it to enter the link correction data value for the first half odd-numbered pixels of the CCD. 0 to 1023

LUT-O-F5	Use it to enter the link correction data value for the first half odd-numbered pixels of the CCD. 0 to 1023
LUT-E-F1	Use it to enter the link correction data value for the first half even-numbered pixels of the CCD. 0 to 1023
LUT-E-F2	Use it to enter the link correction data value for the first half even-numbered pixels of the CCD. 0 to 1023
LUT-E-F3	Use it to enter the link correction data value for the first half even-numbered pixels of the CCD. 0 to 1023
LUT-E-F4	Use it to enter the link correction data value for the first half even-numbered pixels of the CCD. 0 to 1023
LUT-E-F5	Use it to enter the link correction data value for the first half even-numbered pixels of the CCD. 0 to 1023

COPIER>ADJUST>LASER
<LASER>



Use it to adjust the laser output.

If you have replaced the DC controller PCB or cleared the RAM of the DC controller PCB, enter the values indicated on the service sheet.

PVE-OFST Range of adjustment	Use it to adjust the laser B spot position. -300 to 300 <ul style="list-style-type: none"> • A higher value moves the spot toward the rear. • A smaller value moves the stop to the front. The laser A spot moves in keeping with the laser B spot.
LA-DELAY Range of adjustment	Use it to enter the delay value of the laser unit. 0 to 4807 Use it to adjust the delay line of the pixel used to coordinate the laser A and laser B in main scanning direction.  If you have replaced the laser unit, enter the values indicated on the label attached to the laser unit.
LA-PWR-A Range of adjustment	Use it to enter the power adjustment value for the laser A. 0 to 255  If you have replaced the laser unit, enter the power adjustment value for the laser A indicated on the label attached to the unit.
LA-PWR-B Range of adjustment	Use it to enter the power adjustment value for the laser B. 0 to 255  If you have replaced the laser unit, enter the power adjustment value for the laser B indicated on the label attached to the unit.
DLY-FINE Range of adjustment	Use it to fine-adjust the displacement of the laser A or laser B. -16 to 16

<DEVELOP>

Use it to adjust the developing bias.

DE-DC Range of adjustment	Use it to enter the DC output value for image formation. 0 to 600
DE-NO-DC Range of adjustment	Use it to enter the development DC output value for non-image formation. 0 to 600
HVT-DE Range of adjustment	Use it to enter the offset value for the developing high-voltage output of the high-voltage unit. -50 to 50  If you have replaced the high-voltage unit, be sure to enter the value indicated on the label attached to the new high-voltage unit. If you have replaced the DC controller PCB or cleared the RAM on the DC controller PCB, be sure to enter the value indicated on the service sheet.
D-HV-DE Range of adjustment	Use it to enter the offset value for the developing high-voltage output of the DC controller PCB. -100 to 100  If you have replaced the DC controller PCB, be sure to enter the value indicated on the label attached to the new DC controller PCB. If you have cleared the RAM on the DC controller PCB, be sure to enter the value indicated on the service sheet.

COPIER>ADJUST>DENS>BLANK
<DENS>

Use it to fine-tune the copy density auto correction mechanism.

DENS-ADJ

Use it to correct the density of images (copier/printer).
If the output has fogging or its high density area is fuzzy, the F value table is to be corrected.

Range of adjustment

1 to 9; default: 5

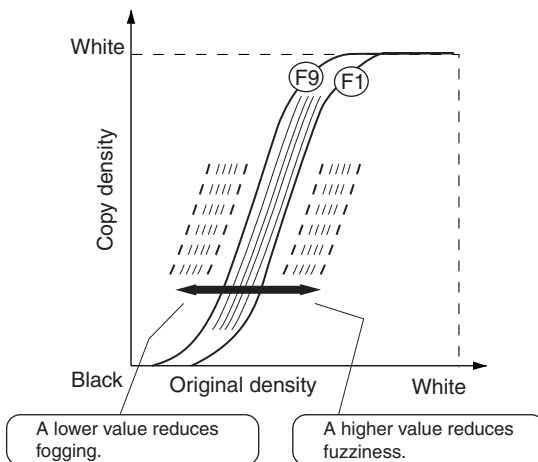

F00-203-07

<BLANK>

Use it to adjust the non-image width.

If you have replaced the DC controller PCB or cleared the RAM of the DC controller PCB, enter the value indicated on the service sheet.

BLANK-T

Use it to enter a value for the image leading edge non-image width.

Range of adjustment

0 to 2392

BLANK-B

Use it to enter a value for the image trailing edge non-image width.

Range of adjustment

0 to 2392

BLANK-TE	Use it to enter a value of the non-image width in image main scanning direction (left, right).
Range of adjustment	10 to 50 (unit: 0.1 mm), default: 25

<V-CONT>

Use it to adjust the potential control system.

If you have replaced the DC controller PCB or cleared the RAM of the DC controller PCB, enter the values indicated on the service sheet.

EPOTOFST	Use it to enter an offset value for the voltage potential sensor.
Range of adjustment	0 to 30
VL-OFST	Use it to enter an offset value for the voltage potential control light-area target voltage potential.
Range of adjustment	-50 to 50 (unit: 1 V)
VD-OFST	Use it to enter an offset value for the voltage potential control dark-area target voltage potential.
Range of adjustment	-50 to 50 (unit: 1 V)
DE-OFST	Use it to enter an offset value for voltage potential control Vdc.
Range of adjustment	-50 to 50 (unit: 1 V)
OHP-OFST	Use it to enter an offset value for Vdc for transparency voltage potential control.
Range of adjustment	-50 to 50 (unit: 1 V)

COPIER>ADJUST>HV-PRI>HV-TR
<HV-PRI>

Use it to control the output of the primary charging assembly.

If you have replaced the DC controller PCB or cleared the RAM on the DC controller PCB, enter the values indicated on the service sheet.

GRID

Use it to enter an adjustment value for the grid current of the primary charging assembly.

**Range of
adjustment**

400 to 900

<HV-TR>

Use it to adjust output of the transfer charging assembly/pre-transfer charging assembly.

TR-N1

Use it to enter an output adjustment value for the transfer charging current (for printing on a single-sided print or on the 1st side of a double-sided print using plain paper).

**Range of
adjustment**

-650 to 0



If you have replaced the DC controller PCB or cleared the RAM on the DC controller, be sure to enter the value indicated on the service sheet.

TR-N2

Use it to enter an output adjustment value for the transfer charging current (for printing on 2nd side of a double-sided print using plain paper).

**Range of
adjustment**

-650 to 0



If you have replaced the DC controller PCB or cleared the RAM on the controller PCB, be sure to enter the value indicated on the service sheet.

PRE-TR





Use it to enter an output adjustment value for the pre-transfer charging.

**Range of
adjustment**

0 to 300







If you have replaced the DC controller PCB or cleared the RAM on the DC controller PCB, be sure to enter the value indicated on the service sheet.

<p>HVT-TR</p> <p>Range of adjustment</p>	<p>Use it to enter an offset value for the transfer high-voltage output of the high-voltage unit.</p> <p>-100 to 100</p> <p> If you have replaced the high-voltage unit, be sure to enter the value indicated on the label attached to the new high-voltage unit. If you have replaced the DC controller PCB or cleared the RAM of the DC controller PCB, be sure to enter the value indicated on the service sheet.</p>
<p>H-PRE-TR</p> <p>Range of adjustment</p>	<p>Use it to enter an offset value for the pre-transfer high-voltage output of the high-voltage unit.</p> <p>-100 to 100</p> <p> If you have replaced the high-voltage unit, be sure to enter the value indicated on the label attached to the new high-voltage unit. If you have replaced the DC controller PCB or cleared the RAM on the DC controller PCB, be sure to enter the value indicated on the service sheet.</p>
<p>D-PRE-TR</p> <p>Range of adjustment</p>	<p>Use it to enter an offset value for the pre-transfer high-voltage output of the DC controller PCB.</p> <p>-100 to 100</p> <p> If you have replaced the DC controller PCB, be sure to enter the value indicated on the label attached to the new DC controller PCB. If you have cleared the RAM of the DC controller PCB, be sure to enter the value indicated on the service sheet.</p>
<p>D-HV-TR</p> <p>Range of adjustment</p>	<p>Use it to enter an offset value for the transfer high-voltage output of the DC controller PCB.</p> <p>-100 to 100</p> <p> If you have replaced the DC controller PCB, be sure to enter the value indicated on the label attached to the new DC controller PCB. If you have cleared the RAM on the DC controller PCB, be sure to enter the value indicated on the service sheet.</p>

COPIER>ADJUST>HV-SP
<HV-SP>



Use it to adjust the output of the separation charging assembly.

<p>SP-N1</p> <p>Range of adjustment</p>	<p>Use it to enter an output adjustment value for the separation charging current (for printing on a single-side print or on the 1st side of a double-sided print using plain paper).</p> <p>0 to 800</p> <p> If you have replaced the DC controller PCB or cleared the RAM on the DC controller PCB, be sure to enter the value indicated on the service sheet.</p>
<p>SP-N2</p> <p>Range of adjustment</p>	<p>Use it to enter an output adjustment value for the separation charging current (for printing on the 2nd side of a double-sided print using plain paper).</p> <p>0 to 800</p> <p> If you have replaced the controller PCB or cleared the RAM of the DC controller PCB, be sure to enter the value indicated on the service sheet.</p>
<p>HVT-SP</p> <p>Range of adjustment</p>	<p>Use it to enter an offset value for the separation high-voltage output of the high-voltage unit.</p> <p>-100 to 100</p> <p> If you have replaced the high-voltage unit, be sure to enter the value indicated on the label attached to the new high-voltage unit. If you have cleared the RAM of the DC controller PCB, be sure to enter the value indicated on the service sheet.</p>
<p>D-HV-SP</p> <p>Range of adjustment</p>	<p>Use it to enter an offset value for the separation high-voltage output of the DC controller PCB.</p> <p>-100 to 100</p> <p> If you have replaced the DC controller PCB, be sure to enter the value indicated on the label attached to the new DC controller PCB. If you have cleared the RAM of the DC controller PCB, be sure to enter the value indicated on the service sheet.</p>

<FEED-ADJ>

Use it to adjust the feeding system.





If you have replaced the DC controller PCB or cleared the RAM on the DC controller PCB, be sure to enter the value indicated on the service sheet.



<p>REGIST</p> <p>Range of adjustment</p>	<p>Use it to adjust the timing at which the registration roller clutch goes ON.</p> <p> A higher value delays the timing at which the registration roller clutch goes ON, thus decreasing the leading edge margin.</p> <p>-100 to 100 (unit: 0.1 mm)</p>
<p>ADJ-REFE</p> <p>Range of adjustment</p>	<p>Use it to adjust the horizontal registration for re-pickup.</p> <ul style="list-style-type: none"> • If the image is displaced to the front, increase the value. <p>-100 to 100 (unit: 0.1 mm)</p> <p> After setting the value, please turn the power switch off and then on.</p>

COPIER>ADJUST>CST-ADJ
<CST-ADJ>

Use it to make cassette/manual feed-related adjustments.

If you have replaced the DC controller PCB or cleared the RAM on the DC controller PCB, be sure to enter the values indicated on the service sheet.

C3-STMTR Range of adjustment	Use it to enter a paper width basic value for the cassette 3. (STMTR) 0 to 255  If you have replaced the paper width detecting VR, execute the following service mode: FUNCTION>CST.
C3-A4R Range of adjustment	Use it to enter a paper width basic value for the cassette 3. (A4R) 0 to 255  If you have replaced the paper width detecting VR, execute the following in service mode: FUNCTION>CST.
C4-STMTR Range of adjustment	Use it to enter a paper width basic value for the cassette 4. (STMTR) 0 to 255  If you have replaced the paper width detecting VR, execute the following in service mode: FUNCTION>CST.
C4-A4R Range of adjustment	Use it to enter a paper width basic value for the cassette 4. (A4R) 0 to 255  If you have replaced the paper width detection VR, execute the following in service mode: FUNCTION>CST.
MF-A4R Range of adjustment	Use it to enter a paper basic value for the manual feed tray. (A4R) 0 to 255  If you have replaced the paper width detecting VR, execute the following in service mode: FUNCTION>CST.

MF-A6R Range of adjustment	Use it to enter a paper width basic value for the manual feed tray. (A6R) 0 to 255  If you have replaced the paper width detecting VR, be sure to execute the following service mode: FUNCTION>CST.
MF-A4 Range of adjustment	Use it to enter a paper width basic value for the manual feed tray. (A4) 0 to 255  If you have replaced the paper width detecting VR, execute the following in service mode: FUNCTION>CST.
C3-LVOL Range of adjustment	Use it to enter a stack height for the cassette 3. (50 sheets) 0 to 255
C3-HVOL Range of adjustment	Use it to enter a stack height for the cassette 3. (250 sheets) 0 to 255
C4-LVOL Range of adjustment	Use it to enter a stack height for the cassette 4. (50 sheets) 0 to 255
C4-HVOL Range of adjustment	Use it to enter a stack height for the cassette 4. (250 sheets) 0 to 255

<EXP-LED>

Use it to adjust the exposure lamp.

If you have replaced the DC controller PCB or cleared the RAM on the DC controller PCB, be sure to enter the value on the service sheet.

PRE-TR Range of adjustment	Use it to enter the output adjustment value for the pre-transfer exposure lamp. 20 to 80
---	--

2.4 FUNCTION

The following shows the Function screen (COPIER>FUNCTION).

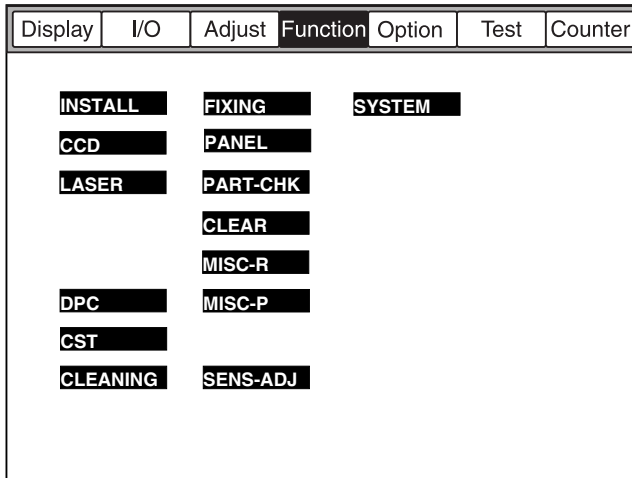

F00-204-01

<INSTALL>

Use it to operate the machine as part of installation work.

<p>TONER-S</p>	<p>Use it to supply toner from the hopper to the developing assembly and to stir the toner inside the developing assembly.</p> <p> • Before pressing the OK key, check to make sure that the developing assembly is securely mounted.</p> <p>• Before pressing the OK key, check to make sure that the control panel monitor indicates the message 'Copier Ready'.</p> <p>• Never turn off the power while the machine is operating.</p> <p><Using the Mode></p> <p>1) Select the item, and press the OK key.</p> <p>2) See that the machine performs toner supply. (about 8 to 10 min)</p> <p>• While the machine supplies toner, it indicates a countdown of the supply time (in sec, starting at 600 sec).</p> <p>3) See the machine automatically stops at the end of toner supply.</p>
<p>CARD</p> <p>Input</p>	<p>Use it to set a number for the card reader.</p> <p>1 to 200</p> <p>Default: 0 (not connected)</p> <p>As many as 1000 cards can be used starting with the one given the pre-set number.</p> <p>EX:</p> <ul style="list-style-type: none"> • If the input is '1', cards from 1 to 1000 can be used. • If the input is 2001, cards from 2001 to 3000 can be used.

COPIER>FUNCTION>CCD
<CCD>

Use it to execute CCD/shading-related auto adjustments.

CCD-ADJ

Use it to execute CCD auto adjustments.



- If you have replaced any of the following or cleared the RAM of the reader controller PCB, execute this mode and LUT-ADJ (LUT-ADJ2): reader controller PCB, CCD, AP PCB, CCD unit, copyboard lamp, fluorescent lamp inverter PCB, copyboard glass, standard white plate, light adjustment PCB, light adjustment sensor PCB.

- Use the whitest of all papers (not for color processing) used by the user as the standard white paper.

<Using the Mode>

- 1) Place the standard white paper (10 sheet or more) on the copyboard glass.
- 2) Select an item, and press the OK key.
- 3) Execute auto adjustment. (about 1 min)
- 4) See that the machine automatically stops after adjustment.
- 5) All items under the following are updated; print out a service sheet, and store it away: COPIER>ADJUST>LAMP, COPIER>ADJUST>CCD.

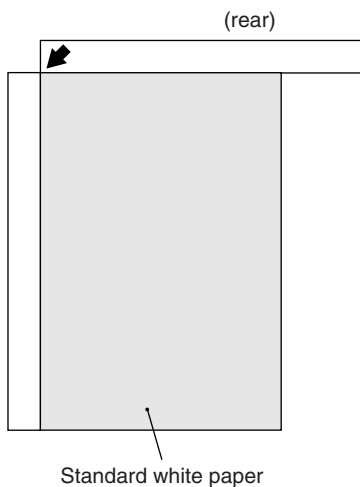

F00-204-02

LUT-ADJ

Use it to execute CCD gain simplified correction.



- After executing CCD-ADJ, execute this mode to adjust the density along the middle of images.
- Be sure to execute CCD-ADJ before executing this mode.

<Using the Mode>

- 1) Select the item, and press the OK key.
- 2) Execute auto adjustment.
- 3) See that the machine automatically stops after adjustment.
- 4) All items under the following are updated; print out a service sheet, and store it away: COPIER>ADJUST>LAMP, COPIER>ADJUST>CCD.

LUT-ADJ2

Use it to execute CCD gain detail correction.

- If the density is not corrected using LUT-ADJ (CCD gain simplified correction), execute this mode using the 10-gradation chart.

<Using the Mode>

- 1) As shown, place the 10-gradation chart (D-10 Test Sheet) on the copyboard glass.
- 2) Select the item, and press the OK key.
- 3) See that the machine executes auto adjustment.
- 4) See that the machine stops automatically after adjustment.
- 5) All items under the following are updated; print out a service sheet, and store it away: COPIER>ADJUST>LAMP, COPIER>ADJUST>CCD.

Place the chart so that the side with gradation faces down.

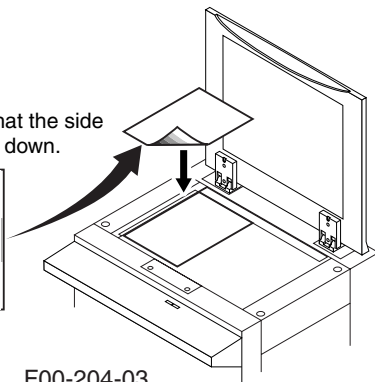
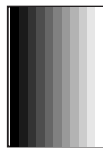

F00-204-03

COPIER>FUNCTION>LASER>DPC
<LASER>

Use it to make laser-related adjustments.

POWER-A

Use it to turn on the laser A.

<Using the Mode>

- 1) Select <POWER-A> to highlight, and press the OK key.
- 2) See that the laser goes ON, and the display indicates 'Start→ACTIVE' (flashing); the upper right of the screen indicates <SERVICE>.
- 3) See that the message goes OFF automatically in about 60 sec, and the display indicates 'OK!'.

POWER-B

Use it to turn on the laser B.

<Using the Mode>

- 1) See the instructions under POWER-A.

<DPC>

Use it to make voltage potential sensor-related adjustments.

OFST

Use it to execute offset adjustment of the potential sensor.



This mode is part of the procedure to be performed when replacing the potential sensor unit; do not execute it on its own.

<Using the Mode>

- 1) Select the item, and press the OK key.
- 2) See that the machine automatically stops after offset adjustment.

<CST>

Use it to execute size auto adjustment for the cassette/manual feed tray.

C3-STMTR
C3-A4R
C4-STMTR
C4-A4R

Use it to register a paper width basic value for the cassette 3/4.
STMTR width: 139.5 mm, A4R width: 210 mm



To make fine adjustments after registering the basic value, execute the following: ADJUST>CST-ADJ>C3-STMTR, C3-A4R, C4-STMTR, C4-A4R.

<Using the Mode>

- 1) Place STMTR paper in the cassette, and see the side guide plate to STMTR width.
- 2) Select C3-STMTR (C4-STMTR), and press the OK key.
 - The machine performs auto adjustment and stores the value.
- 3) Likewise, repeat steps 1) and 2) to enter a basic value.

MF-A4R
MF-A6R
MF-A4

Use it to enter a paper width basic value for the manual feed tray.
A4R width: 210 mm, A6R width: 105 mm, A4 width: 297 mm



To make fine adjustments after registering the basic value, execute the following: ADJUST>CST-ADJ>MF-A4R, MF-A6R, MF-A4.

<Using the Mode>

- 1) Place A4R paper in the manual feed tray, and set the side guide to A4R width.
- 2) Select MF-A4R, and press the OK key.
 - The machine performs auto adjustment and registers the value.
- 3) Likewise, repeat steps 1) and 2) for A6R and A4.

COPIER>FUNCTION>CLEANING
<CLEANING>

Cleaning operation.

WIRE-CLN

Use it to execute auto cleaning of the charging wire 5 times continuously (round trip).



If you have replaced the primary charging wire or the transfer charging wire, be sure to execute this mode.

<Using the Mode>

- 1) Select the item, and press the OK key.
- 2) See that the machine performs auto cleaning of the charging wire 5 times continuously.
- 3) See that the machine automatically stops after cleaning.

<FIXING>

Use it to execute fixing assembly-related auto adjustment.

NIP-CHK

Use it to generate output for measuring the fixing nip width.

<Using the Item>

- 1) Make about 20 A4 prints using the test sheet.
- 2) Place A4 paper in the tray.
- 3) Select the item to highlight, and press the OK key.
 - The paper will be picked up and is stopped between the fixing rollers once, and then will be delivered in about 20 sec.
- 4) Measure the width of the area shaded in the figure.

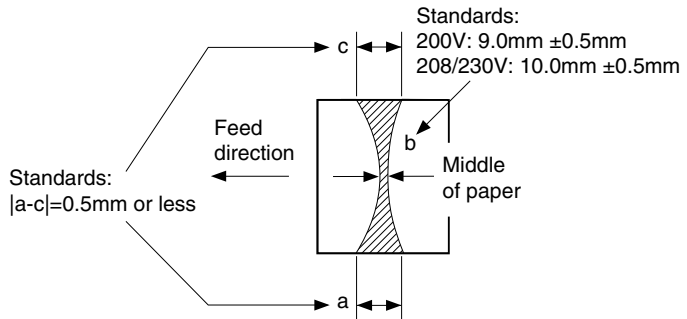

F00-204-04



a and b are measurements at 10 mm from either edge of paper.

COPIER>FUNCTION>PANEL
<PANEL>

Use it to turn on the control panel.

LCD-CHK	<p>Use it to check the touch panel for missing dots.</p> <p><Using the Mode></p> <ol style="list-style-type: none"> 1) Select the item, and press the OK key. <ul style="list-style-type: none"> • The entire face of the touch panel repeats turning white, black, red, green, and blue. 2) Press the Stop key to stop the operation.
LED-CHK	<p>Use it to check the LEDs of the control panel.</p> <p><Using the Mode></p> <ol style="list-style-type: none"> 1) Select the item, and press the OK key. <ul style="list-style-type: none"> • The LEDs go ON in sequence. 2) Select LED-OFF to stop the operation.
LED-OFF	<p>Use it to end a check on the LEDs of the control panel.</p> <p><Using the Mode></p> <ol style="list-style-type: none"> 1) Select the item to end LED-CHECK.
KEY-CHK	<p>Use it to check key inputs.</p> <p><Using the Mode></p> <ol style="list-style-type: none"> 1) Select the item. 2) Press the key to check. If normal, its corresponding character appears on the touch panel. (T00-204-01) 3) At the end, select KEY-CHECK once again to end the operation.
TOUCHKEY	<p>Use it to adjust the coordinates of pressing and locations on the touch panel.</p> <p> • Try to match a press on the touch panel and its coordinates on the LCD.</p> <p>• If you have replaced the LCD assembly, execute this mode.</p> <p><Using the Mode></p> <ol style="list-style-type: none"> 1) Select the item, and press the OK key. 2) Press the 9 locations indicated by '+' on the touch panel.

<Input Keys and Display>

Key	Display	Key	Display
counter check	BILL	Start	START
0 to 9	0 to 9	Reset	RESET
Stop	STOP	Power Save	STAND BY
ID	ID	Clear	CLEAR
User Mode	USER	Guide	?

T00-204-01

<PART-CHK>

Use it to check the operation of each load.

CL	<p>Use it to select the clutch to check.</p> <p><Using the Mode></p> <ol style="list-style-type: none"> 1) Select the item. 2) Using the keypad, enter the code (T00-204-02) of the clutch in question. 3) Press the OK key.
CL-ON	<p>Use it to check the operation of a clutch.</p> <p><Using the Mode></p> <ol style="list-style-type: none"> 1) Select the item, and press the OK key. <ul style="list-style-type: none"> • ON → 10 sec OFF → ON → 10 sec OFF → ON → OFF
MTR	<p>Use it to select the motor to check.</p> <p><Using the Mode></p> <ol style="list-style-type: none"> 1) Select the item. 2) Enter the code (T00-204-03) of the motor using the keypad. 3) Press the OK key.
MTR-ON	<p>Use it to check the operation of a motor.</p> <p><Using the Mode></p> <ol style="list-style-type: none"> 1) Select the item, and press the OK key. <ul style="list-style-type: none"> • 20 sec ON → OFF • for hopper and duplex horizontal registration motor, 10 sec ON → OFF • for shift tray motor, stops at front/rear HP • for vibration motor (M10/M20), ON/OFF operation repeats at intervals of about 5 sec

COPIER>FUNCTION>PART-CHK

SL

Use it to select a solenoid to check.
 <Using the Mode>
 1) Select the item.
 2) Using the keypad, enter the code (T00-204-04) of the solenoid.
 3) Press the OK key.

SL-ON

Use it to check the operation of a solenoid.
 <Using the Item>
 1) Select the item, and press the OK key.
 • ON → 10 sec OFF → ON → 10 sec OFF → ON → OFF

<Codes/Clutch Names>

Code	Name	Code	Name
1	manual feed tray pickup clutch (CL7)	12	lower feeder right clutch (CL17)
2	cassette 3 pickup clutch (CL12)	13	deck (left) feed clutch (CL19)
3	vertical path 3 clutch (CL13)	14	delivery speed switch-over clutch (CL21)
4	cassette 4 pickup clutch (CL14)	15	registration brake clutch (CL3)
5	vertical path 4 clutch (CL15)	16	manual feed tray feed clutch (CL18)
6	deck (right) pickup clutch (CL10)	17	inside hopper magnet roller drive clutch (CL1)
7	vertical path 1 clutch (CL8)	18	developing sleeve clutch (CL4)
8	deck (left) pickup clutch (CL11)	19	registration clutch (CL2)
9	vertical path 2 clutch (CL9)	20	side paper deck feed clutch (CL101)
10	pre-registration clutch (CL5)	21	side paper deck pickup clutch (CL102)
11	lower feeder middle clutch (CL6)		

T00-204-02

<Codes/Motor Names>

Code	Name	Code	Name
1	Drum motor (M0)	8	Horizontal registration motor (M15)
2	Main motor (M1)	9	Duplex reversal motor (M11)
3	Pickup motor (M2)	10	duplex feed motor (M12)
4	Fixing motor (M3)	11	deck main motor (M101)
5	Laser scanner motor (M4)	12	vibration motor 1 (M10)
6	Inside cartridge toner feed motor (M6)	13	vibration motor 2 (M20)
7	Inside hopper toner feed motor (M18)		

T00-204-03

<Codes/Solenoid Names>

Code	Name	Code	Name
1	deck (right) pickup solenoid (SL7)	8	reversal flapper solenoid (SL11)
2	deck (left) pickup solenoid (SL8)	9	fixing web solenoid (SL2)
3	cassette 3 pickup solenoid (SL9)	10	fixing feed unit lock solenoid (SL4)
4	cassette 4 pickup solenoid (SL10)	11	fixing feed unit lock solenoid (SL4)
5	manual feed pickup clutch solenoid (SL6)	12	shut-off
6	manual feed pickup clutch solenoid (SL6)	13	side paper deck pickup solenoid
7	delivery flapper solenoid (SL3)	14	relay

T00-204-04

COPIER>FUNCTION>CLEAR
<CLEAR>

Use it to clear the RAM/jam history/error code history.

Be sure to turn off and then on the main power switch for the change to be stored.

ERR	<p>Use it to clear an error code. <Using the Mode></p> <ol style="list-style-type: none"> 1) Select the item, and press the OK key. 2) Turn off and then on the main power switch.
DC-CON	<p>Use it to clear the RAM of the DC controller PCB. <Using the Mode></p> <ol style="list-style-type: none"> 1) Select the item and press the OK key. 2) Turn off and then on the main power switch.
R-CON	<p>Use it to clear the RAM of the reader controller PCB. <Using the Mode></p> <ol style="list-style-type: none"> 1) Select the item, and press the OK key. 2) Turn off and then on the main power switch.
SERVICE	<p>Use it to clear the backup data of service mode (COPIER>OPTION). <Using the Mode></p> <ol style="list-style-type: none"> 1) Use the item, and press the OK key. 2) Turn off and then on the main power switch.
JAM-HIST	<p>USE it to clear the jam history. <Using the Mode></p> <ol style="list-style-type: none"> 1) Select the item, and press the OK key. 2) Turn off and then on the main power switch.
ERR-HIST	<p>USE it to clear the error history. <Using the Mode></p> <ol style="list-style-type: none"> 1) Select the item, and press the OK key. 2) Turn off and then on the main power switch.
E354-CLR	---
E355-CLR	---

PWD-CLR	<p>Use it to clear the password of the system administrator set in user mode. <Using the Mode></p> <ol style="list-style-type: none"> 1) Select the item, and press the OK key. 2) Turn off and then on the main power switch.
ADRS-BK	<p>Use it to clear all addresses registered in the address book. <Using the Mode></p> <ol style="list-style-type: none"> 1) Select the item, and press the OK key. 2) Turn off and then on the main power switch.
CNT-MCON	<p>Use it to clear the counter readings used for service work on the main controller PCB. <Using the Mode></p> <ol style="list-style-type: none"> 1) Select the item, and press the OK key. 2) Turn off and then on the main power switch.
CNT-DCON	<p>Use it to clear the counter readings for service work on the DC controller PCB. <Using the System></p> <ol style="list-style-type: none"> 1) Select the item and press the OK key. 2) Turn off and then on the main power switch.
MMI	<p>Use it to clear the backup data entered in user mode (machine settings, ID mode, group ID, mode memory). <Using the Mode></p> <ol style="list-style-type: none"> 1) Select the item, and press the OK key. 2) Turn off and then on the main power switch.
CARD	<p>Use it to clear the group ID of the card reader. <Using the Mode></p> <ol style="list-style-type: none"> 1) Select the item, and press the OK key. 2) Turn off and then on the main power switch.
ALARM	<p>Use it to clear the alarm history. <Using the Mode></p> <ol style="list-style-type: none"> 1) Select the mode, and press the OK key. 2) Turn off and then on the main power switch.

COPIER>FUNCTION>MISC-R>MISC-P
<MISC-R>

Use it to check the operation of the reader system.

SCANLAMP

Use it to check the activation of the scanning lamp.

<Using the Mode>

- 1) Select the item, and press the OK key.
 - See that the scanning lamp goes ON.
- 2) See that the scanning lamp remains ON for several seconds and go OFF automatically.

<MISC-P>

Use it to check the operation of the printer system.

P-PRINT

Use it to print out a list of service mode settings (COPIER>ADJUST/OPTION/COUNTER).

<Using the Mode>

- 1) Select the item, and press the OK key.
 - See that a list of service mode settings is printed out.

KEY-HIST

Use it to print out the history of key inputs made from the control panel.

<Using the Mode>

- 1) Select the item, and press the OK key.
 - See that the history of key inputs is printed out.

HIST-PRT

Use it to print out the jam history, error history, and alarm history of service mode.

<Using the Mode>

- 1) Select the item, and press the OK key.
 - See that histories of jams, errors, and alarms are printed out.

USER-PRT

Use it to print out a list of user mode settings from service mode.

<Using the Mode>

- 1) Select the item, and press the OK key.
 - See that a list of user mode settings is printed out.

P-TR-EXP	<p>Use it to check the activation of the pre-transfer exposure lamp. <Using the Mode></p> <ol style="list-style-type: none"> 1) Select the item, and press the OK key. <ul style="list-style-type: none"> • The pre-transfer exposure lamp goes ON. 2) See that the pre-transfer exposure lamp remains ON for several seconds and go OFF automatically.
LBL-PRNT	<p>Use it to print out the service sheet. <Using the Mode></p> <ol style="list-style-type: none"> 1) Place paper in the manual feed tray. <ul style="list-style-type: none"> •  When printing out the service sheet, be sure to use the manual feed tray as the source of paper. 2) Select the item, and press the OK key. <ul style="list-style-type: none"> • The service sheet is printed out. • Store the service sheet in the service book case behind the front cover.
PRE-EXP	<p>Use it to check the activation of the pre-exposure lamp. <Using the Mode></p> <ol style="list-style-type: none"> 1) Select the item, and press the OK key. <ul style="list-style-type: none"> • See that the pre-exposure lamp goes ON. 2) See that the pre-exposure lamp goes OFF automatically in several seconds.
CL-ADJ	<p>Use it to measure the clutch lock/unlock mechanism. <Using the Mode></p> <ol style="list-style-type: none"> 1) Place 2 or more sheets of paper in the left deck and 1 sheet or more in the cassette 4 (if a Paper Deck is connected, 1 sheet in it); use A4/LTR plain paper. 2) Select the item, and press the OK key. <ul style="list-style-type: none"> • See that the 2 sheets are picked from the left deck and 1 sheet from the cassette 4 (1 sheet from the Paper Deck if connected). 3) When all sheets have been delivered, see that the machine indicates 'NG' to shows that the mechanism is normal; otherwise, it will indicate 'NG'.

COPIER>FUNCTION>SENS-ADJ>SYSTEM
<SENS-ADJ>

Use it to adjust sensors.

OP-SENS

Use it to adjust optical sensor.

<Using the Mode>

- 1) Check to make sure that paper is found in all paper cassettes.
- 2) Select the item, and press the OK key.
- 3) See that the machine indicates 'ACTIVE' during adjustment and 'OK' when the sensor is normal; otherwise, it will indicate 'NG'.

<SYSTEM>

Use it to check system-related operations.

DOWNLOAD

Use it to switch to download mode of the system program.



Use it when downloading the system program.

<Using the Mode>

- 1) Turn off the copier and the PC.
- 2) Disconnect the network-related cable from the copier.
- 3) Connect the copier and the PC with a bi-Centronics cable or a network cable.
- 4) Turn on the PC.
- 5) Turn on the copier.
- 6) Select the item, and press the OK key.
- 7) Perform downloading using the service support tool. (See 7. of Chapter 6.)
- 8) When downloading ends, turn off and then on the main power switch.

CHK-TYPE

Use it to select a partition number for execution of HD-CHECK, HD-CLEAR.

<Using the Mode>

- 1) Select the item.
- 2) Select a partition number using the keypad.
 - 0: entire HDD
 - 1: image storage area
 - 2: general-purpose file storage area
 - 3: PDL-related file storage area
 - 4: program file storage area
- 3) Press the OK key.

HD-CHECK

Use it to check and recover the partition selected using CHK-TYPE.

<Using the Mode>

- 1) Select the item.
- 2) Press the OK key.
- 3) See the result.

OK/NG (hardware)/NG (software) recovery sector/alternative sector

HD-CLEAR

Use it to initialize the partition selected using CHK-TYPE.

<Using the Mode>

- 1) Select the item.



CHK-TYPE: 0 and 4 are invalid

- 2) Press the OK key.
- 3) At the end, see that 'OK' is indicated.

2.5 OPTION

The following shows the Option screen (COPIER>OPTION).

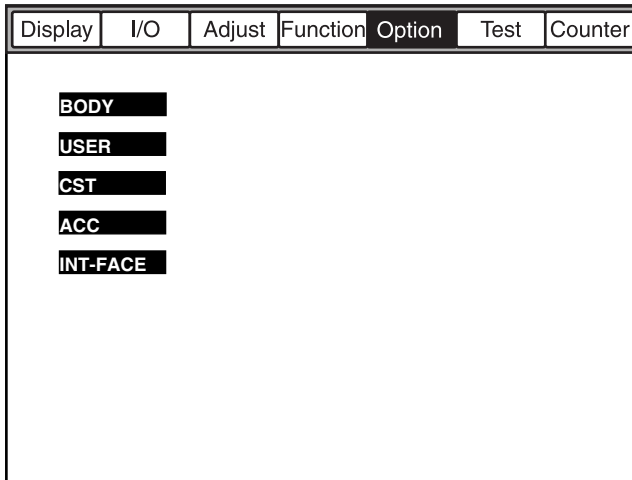

F00-205-01





Be sure to turn off and then on the main power switch so that changes made to any of the items under COPIER>OPTION are effective.



<BODY>

Use it to select copier-related settings.



PO-CNT Setting	Use it to turn on and off the potential control mechanism. 0: OFF 1: ON (default)
TRNSG-SW Setting	Use it to select toner guide bias control mode. 0: 200 V for absolute water content of 22 g or more; 600 V for others 1: fixed to 600 V 2: fixed to 200 V 3: 200 V for absolute water content of 18 g or more; 600 V for others (default) 4: 200 V for absolute water content of 14 g or more; 600 V for others
MODEL-SZ Setting	Use it to switch default reproduction ratio display and ADF original size detection. 0: AB (6R5E) 1: INCH (5R4E) 2: A (3R3E) 3: AB/INCH (6R5E)
FIX-TEMP Setting	Use it to set the down sequence start temperature for thick paper mode. 0: 194°C 1: 189°C (default) 2: 184°C
IDL-MODE Setting	Use it to select idle rotation mode for the developing assembly.  Set it to '2' or '3' if the image becomes distorted or too light. 0: OFF (no idle rotation) 1: auto control based on readings of environment sensor (default) 2: start idle rotation when fixing roller temperature reaches 100°C 3: start idle rotation when main power switch goes ON

COPIER>OPTION>BODY

FUZZY	<p>Use it to set fuzzy control (on/off) and environment settings</p>  <ul style="list-style-type: none"> • It affects the pre-transfer, transfer, and separation charging current levels. • Setting it between '1' and '3' makes the control independent of the readings of the environment sensor. <p>Setting</p> <p>0: fuzzy control ON (default) 1: low humidity environment mode (uses level lower than standard) 2: normal humidity environment mode 3: high humidity environment mode (uses level higher than standard)</p>
SCANSLCT	<p>Use it to turn ON/OFF the original size detection mechanism by the ADF.</p>  <p>When ON, the scan size is determined according to the size of an original.</p> <p>Setting</p> <p>0: OFF (default) 1: ON</p>
OHP-TEMP	<p>Use it to switch among temperature settings for transparency mode.</p>  <p>The fixing temperature will be lowered to improve separation of transparencies from the fixing roller.</p> <p>Setting</p> <p>0: 198°C (default) 1: 193°C 2: 188°C 3: 183°C</p>
OHP-CNT	<p>Use it to turn ON/OFF the potential control mechanism for transparency mode.</p> <p>Setting</p> <p>0: use target value obtained in potential control of transparency mode (default) 1: do not use potential control in transparency mode</p>
CNT-W/PR	<p>Use it to turn ON/OFF the mechanism to change density during printing (PDL input).</p> <p>Setting</p> <p>0: correct target value to enable change of density during printing (default) 1: do not change density during printing</p>

<p>FIX-TMP1</p> <p>Setting</p>	<p>Use it to select a temperature for starting down-sequence for plain paper.</p> <p> If the user wants priority on image quality, set it to '0'; on speed, set it to '2'.</p> <p>0: 183°C 1: 178°C (default) 2: 173°C</p>
<p>TRSW-P-B</p> <p>Setting</p>	<p>Use it to turn ON/OFF the transfer current output correction mechanism at the trailing edge of paper.</p> <p>0: ON 1: OFF (default)</p>
<p>SP-MODE</p> <p>Setting</p>	<p>Use it to turn ON/OFF the separation current output correction mechanism.</p> <p>0: standard mode (default) 1: low voltage mode</p>
<p>FTMP-DWN</p> <p>Setting</p>	<p>USE it to select enhanced stacking mode.</p> <p> The fixing temperature is lowered to enhance stacking in the finisher.</p> <p>0: OFF (default) 1: decrease by -5°C 2: decrease by -10°C 3: decrease by -15°C</p>
<p>DRUM-CLN</p> <p>Setting</p>	<p>Use it to select enhanced drum cleaning mode (stop sequence).</p> <p> • The rotation of the drum is stopped for about 1 sec as soon as a specific number of prints have been made during copying, thereby recovering the cleaning performance of the cleaning blade.</p> <ul style="list-style-type: none"> • If cleaning faults occur, use this mode to change the setting. • A higher setting brings stronger results. <p>0: 1000 single-sided copies (500 double-sided copies) (default) 1: 500 single-sided copies (250 double-sided copies) 2: 250 single-sided copies (125 double-sided copies) 3: if absolute water content is 9 g or more, 1000 single-sided copies (500 double-sided copies) after passage of paper if absolute water content is less than 9 g, 250 single-sided copies (125 double-sided copies) after passage of paper 4: do not stop rotation</p>

COPIER>OPTION>BODY

<p>DRM-IDL</p> <p>Setting</p>	<p>Use it to set idle rotation mode for the photosensitive drum executed at time of power-on.</p> <p> The photosensitive drum is rotated idly to prevent adhesion of toner to the drum. Set it between '1' and '4' if the image is distorted or too light.</p> <p>0: do not use idle rotation (default) 1: if absolute water content is 18 g or more, rotate for 30 sec 2: if absolute water content is 18 g or more, rotate for 2 min 3: regardless of environment, rotate for 30 sec 4: regardless of environment, rotate for 2 min 5: regardless of environment, rotate for 2 min; after wire cleaning, rotate for 5 sec 6: regardless of environment, rotate for 2 min; after wire cleaning, rotate for 10 sec 7: regardless of environment, rotate for 2 min; after wire cleaning, rotate for 30 sec</p>
<p>FX-FANSW</p> <p>Setting</p>	<p>Use it to set the control mechanism for the fixing heat discharge fan.</p> <p> If set to '1', the fan is controlled to half speed after copying/printing.</p> <p>0: full speed (default) 1: half speed</p>
<p>CONFIG</p> <p>Setting</p>	<p>Use it to select from multiple pieces of firmware stored on the hard disk for country, language, destination, paper size configuration.</p> <p>XXYYZZAA XX: country (JP), YY: language (ja), ZZ (00): destination, AA (00): paper size configuration; as determined by COPIER>DISPLAY>USER>LANGUAGE. The selections in parentheses indicate default selections.</p> <p><Using the Mode> 1) Select 'CONFIG'. 2) Select a specific item to change (highlight), and press the +/- key.  You can change XX: country and AA (00) paper size configuration. 3) Press the +/- key to scan through the selections. 4) Bring up the selections for each time, and press the OK key. 5) Turn off and then on the main power switch.</p>

SHARP	Use it to change the sharpness level of images. • A higher value makes images sharper.
Setting	1 to 5 (default: 3)
FDW-DLV	Use it to switch between face-up and face-down delivery mode, thereby ensuring good stacking when making multiple prints.
Setting	0: normal (face-up for all when using 1 original) 1: when using 1 original, face-up if for one set; face-down if for multiple sets (default)
COTDPC-D	Use it to set toner save mode.
Setting	0: do not use toner save mode (default) 1: VDT-20V of coy image, VDT-P25V of print image (target of -10%, approx.) 2: VDT-40V of copy image, VDT-P-50V of print image (target of -20%, approx.) 3: VDT-60V of copy image, VDT-P-75V of print image (target of -30%, approx.)
RMT-LANG	not used
TR-SP-C1	Use it to set the transfer/separation output setting when the right deck is selected, thereby preventing faults otherwise occurring.
Setting	0: setting for plain paper (default) 1: setting for recycled paper 2: setting for tracing paper
TR-SP-C2	Use it to set the transfer/separation output setting when the left deck is used, thereby preventing faults otherwise occurring.
Setting	0: setting for plain paper (default) 1: setting for recycled paper 2: setting for tracing paper

COPIER>OPTION>BODY

<p>TR-SP-C3</p> <p>Setting</p>	<p>Use it to set the transfer/separation output setting when the cassette 3 is used, thereby preventing faults otherwise occurring.</p> <p>0: setting for plain paper (default) 1: setting for recycled paper 2: setting for tracing paper</p>
<p>TR-SP-C4</p> <p>Setting</p>	<p>Use it to set the transfer/separation output setting when the cassette 4 is used, thereby preventing faults otherwise occurring.</p> <p>0: setting for plain paper (default) 1: setting for recycled paper 2: setting for tracing paper</p>
<p>TR-SP-MF</p> <p>Setting</p>	<p>Use it to set the transfer/separation output setting when the manual feed tray is used, thereby preventing faults otherwise occurring.</p> <p>0: setting for plain paper (default) 1: setting for recycled paper 2: setting for tracing paper</p>
<p>TR-SP-DK</p> <p>Setting</p>	<p>Use it to set the transfer/separation output setting when the side paper deck is used.</p> <p>0: setting for plain power (default) 1: setting for recycled paper 2: setting for tracing paper</p>
<p>DF-BLINE</p> <p>Setting</p>	<p>Use it to turn ON/OFF the dust detection mechanism for ADF stream reading mode.</p> <p>0: ON (default) 1: OFF</p>
<p>THICK-PR</p> <p>Setting</p>	<p>Use it to set the potential control mechanism for thick paper mode.</p> <p>0: use value determined by potential control in plain paper mode (default) 1: use value determined by potential control in transparency mode</p>
<p>DEV-SLOW</p> <p>Setting</p>	<p>Use it to set the speed of the developing sleeve.</p> <p>0: in relation to environment 1: fixed to high speed 2: fixed to low speed (default)</p>

TEMP-TBL	Use it to select a fixing temperature.
Setting	<p>200V 208V/230V</p> <p>0: 183°C 0: 193°C</p> <p>1: 193°C 1: 198°C</p> <p>2: 178°C 2: 188°C</p> <p>3: 173°C 3: 183°C</p> <p>4: 168°C 4: 178°C</p>
DRM-H-SW	Use it to set the night drum heater OFF mode.
Setting	<p>0: night drum heater ON (default)</p> <p>1: monitor ambient humidity every 2 hr; turn off drum heater if absolute water content is 9 g or less</p>
DEV-IDLR	Use it to set black band developing forced idle rotation mode used at time of power-on.
Setting	<p>0: execute black band developing idle rotation sequence at power-on if 2000 copies or more were made on previous day and, in addition, absolute water content is 16 g or more (default)</p> <p>1: execute black band developing idle rotation sequence at power-on at all times</p>
BK-BD-1	Use it to set black band monthly remedial mode (for January).
Setting	<p>0: do not execute if absolute water content is less than 9 g execute every 200 copies if absolute water content is 9 g or more (default)</p> <p>1: execute black band sequence every 60 copies</p> <p>2: execute black band sequence every 20 copies</p> <p>3: execute black band sequence every 6 copies</p>
BK-BD-2	Use it to set black band monthly remedial mode (for February).
Setting	Same as for January.
BK-BD-3	Use it to set black band monthly remedial mode (for March).
Setting	Same as for January.
BK-BD-4	Use it to set black band monthly remedial mode (for April).
Setting	Same as for January.

COPIER>OPTION>BODY

BK-BD-5	Use it to set black band monthly remedial mode (for May). Setting Same as for January.
BK-BD-6	Use it to set black band monthly remedial mode (for June). Setting Same as for January.
BK-BD-7	Use it to set black band monthly remedial mode (for July). Setting Same as for January.
BK-BD-8	Use it to set black band monthly remedial mode (for August). Setting Same as for January.
BK-BD-9	Use it to set black band monthly remedial mode (for September). Setting Same as for January.
BK-BD-10	Use it to set black band monthly remedial mode (for October). Setting Same as for January.
BK-BD-11	Use it to set black band monthly remedial mode (for November). Setting Same as for January.
BK-BD-12	Use it to set black band monthly remedial mode (for December). Setting Same as for January.
PAPER-TY	Use it to switch paper types. Setting 0 to 2 0: destination (as set at time of shipment; default) 1: for 200V model 2: for 208/230V model



VBR-M-SW	Use it to set vibration motor mode.
Setting	<p>0 to 4</p> <p>0: ON only if water content is 9 g/kg (after multiple rotation) and during pre-transfer/separation charging assembly wire cleaning.</p> <p>1: OFF regardless of water content (stop interval of stop sequence set at 1.5 sec)</p> <p>2: ON after multiple rotation and during STOP sequence regardless of water content</p> <p>3: ON after multiple rotation and during STOP sequence only if water content is less than 9 g/kg</p> <p>4: ON after multiple rotation and during STOP sequence and for transfer/separation charging assembly wire cleaning (default)</p> <p> During initial multiple rotation (at first power-on), the mode is turned ON 5 times; for others, it is turned ON once.</p>

<USER>

Use it to make user-related machine settings.

COPY-LIM	Use it to change the upper limit imposed on the number of copies to make.
Setting	1 to 999 copies (default: 999)
SLEEP	Use it to turn ON/OFF sleep mode.
Setting	<p>0: OFF</p> <p>1: ON (default)</p>
WEB-DISP	Use it to turn ON/OFF the fixing web length message.
Setting	<p> 0: OFF (do not issue; but issued only when in service mode)</p> <p>1: ON (issue)</p>
SIZE-DET	Use it to turn ON/OFF the original size detection mechanism.
Setting	<p>0: OFF (default)</p> <p>1: ON</p>

COPIER>OPTION>USER

W-TONER	<p>Use it to turn ON/OFF the waste toner case full warning message.</p>  0: OFF (do not issue; but issue only when in service mode)
Setting	<p>0: OFF (do not issue; default) 1: ON (issue)</p>
COUNTER1	<p>Use it to set the soft counter 1 in the control panel.</p> <p>101: total 1 (default: fixed to 101; T00-205-01)</p>  You cannot change the type of the soft counter 1.
COUNTER2	<p>Use it to change the type of the counter 2 to suit the user's or the dealer's needs.</p> <p>Setting 000 to 804 (T00-205-01; default: 000 for 100V mode, 103 for 208/230V model)</p>
COUNTER3	<p>Use it to change the type of the counter 3 to suit the user's or the dealer's needs.</p> <p>Setting 000 to 804 (T00-205-01; default: 00 for 100V model, 201 for 208/230V model)</p>
COUNTER4	<p>Use it to change the type of the counter 4 to suit the user's or the dealer's needs.</p> <p>Setting 000 to 804 (T00-205-01; default: 000 for 100V model, 203 for 208/230V model)</p>
COUNTER5	<p>Use it to change the type of the soft counter 5 to suit the user's or the dealer's needs.</p> <p>Setting 00 to 804 (T00-205-01; default: 000)</p>
COUNTER6	<p>Use it to change the type of the soft counter 6 to suit the user's or the dealer's needs.</p> <p>Setting 00 to 804 (T00-205-01; default: 000)</p>

DATE-DSP	<p>Use it to change the mode of notation for the 208V model.  For the 208V model, the default is '1'.</p>
Setting	<p>0: YYYY MM/DD (default) 1: DD/MM YYYY 2: MM/DD/YYYY</p>
MB-CCV	<p>Use it to impose restrictions on the Box function (not used for the copier in question; by Control Card IV).</p> <p>0: for remote, enable operation and printing regardless of presence/absence of card and do not charge 1: for remote, enable operation regardless of presence/absence of card. A print job may be sent, but printing will not occur in the absence of a card; if a card is used, printing is enabled but is changed. (default) 2: for remote, disable operation. No print job may be sent.</p>
PR-D-SEL	<p>Use it to set the density for printing (PDL input).</p> <p>0 (light) ⇔ 4 (standard (default)) ⇔ 8 (dark)</p>
CONTROL	<p>Use it to enable/disable the PDL count function. (not used in the copier in question)</p> <p>0: do not count PDL output 1: count PDL output if control card is connected</p>
B4-L-CNT	<p>Use it to specify whether soft counter 1 through 6 should count B4 as large-size or small-size.</p> <p>0: small-size (default) 1: large-size</p>
TRY-STP	<p>Use it to prohibit suspension of printing in relation to the number of sheets in a stack to staple or a stack of different size sheets in the finisher.</p> <p>0: normal mode (suspend printing for number of sheets/mix of different size sheets; default) 1: suspend printing if height sensor is ON (full of paper)</p>

COPIER>OPTION>USER

MF-LG-ST Setting	Use it to display the Extra Length key for paper up to 630 mm in manual feed, or up to 630 mm in ADF feed. 0: normal mode (default) 1: extra length mode (display key)
SPECK-DP Setting	Use it to enable/disable the warning for the result of dust detection for stream reading. 0: disable 1: enable (default)
CNT-DISP Setting	Use it to enable/disable the indication of the serial number in response to a press on the Counter Check key. 0: enable (default) 1: disable
PH-D-SEL Setting	Use it to see the number of lines in photo mode printing. 0: 141 lines (default) 1: 134 lines
COPY-JOB Setting	Use it to disable copy job auto start when a card reader and the coin robot is used. 0: enable copy job auto start (default) 1: disable copy job auto start
NW-SCAN Setting	Use it to enable/disable the network scan function.  • You cannot make a change in the 100V model. • You can make a change in the 208/230V model; however, for the PS/PCL model, it is fixed to '1'. 0: disable (default) 1: enable
INS-C/S Setting	Use it to expand the inserter function. 0: cover mode (default) 1: Not used (for future expansion)
TBIC-RNK Setting	Use it to reduce uneven density occurring at specific intervals. 1 to 5 (default: 2)

ORG-ODR

Use it to set the sequence in which double-sided originals are read when the original orientation detection mechanism is enabled.

Setting**0: back → face (default)****1: face → back**

COPIER>OPTION>USER

<Soft counter Specifications>

The soft counters are grouped into the following in reference to input numbers:

- | | |
|--------------------|-----------------------|
| 100s: total | 500s: scan |
| 200s: copy | 600s: box |
| 300s: print | 700s: reception print |
| 400s: copy + print | 800s: report print |

- Guide to Symbols Used in the Table -

- ○: counter enabled in copier
- 4C: full color
- Mono: mono color (Y, M, C; R, G, B; aged mono)
- Bk: black mono
- L: large size (larger than B4)
- S: small size (B4 or smaller)
- Number in Counters
 - 1: up by 1 for large-size sheet
 - 2: up by 2 for large-size sheet

You can set the machine in service mode so that B4 and larger may be counted as B4:

COPIER>OPTION>USER>B4-L-CNT.

Support No.	Counter	Support No.	Counter
○	000 not indicated	○	204 copy (S)
○	101 total 1	○	205 copy A (total 1)
○	102 total 2	○	206 copy A (total 2)
○	103 total (L)	○	207 copy A (L)
○	104 total (S)	○	208 copy A (S)
	105 total (4C1)	○	209 local copy (total 1)
	106 total (4C2)	○	210 local copy (total 2)
	107 total (Mono)	○	211 local copy (L)
	108 total (Bk1)	○	212 local copy (S)
	109 total (Bk2)	○	213 remote copy (total 1)
	110 total (Mono/S)	○	214 remote copy (total 2)
	111 total (Mono/S)	○	215 remote copy (L)
	112 total (Bk/L)	○	216 remote copy (S)
	113 total (Bk/S)	○	217 copy (4C1)
○	114 total		218 copy (4C2)
	(4C + Mono + Bk/double-sided)		219 copy (Mono1)
	total 1 (double-sided)		220 copy (Mono2)
○	115 total 2 (double-sided)		221 copy (Bk1)
○	116 L (double-sided)		222 copy (Bk2)
○	117 S (double-sided)		223 copy (4C/L)
○	201 copy (total 1)		224 copy (4C/S)
○	202 copy (total 2)		225 copy (Mono/L)
○	203 copy (L)		226 copy (Mono/S)

T00-205-01

			COPIER>OPTION>USER		
Support No.	Counter		Support No.	Counter	
	227	copy (Bk/L)	<input type="radio"/>	331	PDL print (total 1)
	228	copy (Bk/S)	<input type="radio"/>	332	PDL print (total 2)
	229	copy (4C + Mono/L)	<input type="radio"/>	333	PDL print (L)
	230	copy (4C + Mono/S)	<input type="radio"/>	334	PDL print (S)
	231	copy (4C + Mono/2)		401	copy + print (4C/L)
	232	copy (4C + Mono/1)		402	copy + print (4C/S)
	233	copy (4C/L/double-sided)		403	copy + print (Bk/L)
	234	copy (4C/S/double-sided)		404	copy + print (Bk/S)
	235	copy (Mono/L/double-sided)		405	copy + print (Bk2)
	236	copy (Mono/S/double-sided)		406	copy + print (Bk1)
	237	copy (Bk/L/double-sided)		407	copy + print (4C + Mono/L)
	238	copy (sided/S/double-sided)		408	copy + print (4C + Mono/S)
<input type="radio"/>	301	print (total 1)		409	copy + print (4C + Mono/2)
<input type="radio"/>	302	print (total 2)		410	copy + print (4C + Mono/1)
<input type="radio"/>	303	print (L)		411	copy + print (L)
<input type="radio"/>	304	print (S)		412	copy + print (S)
<input type="radio"/>	305	print A (total 1)		413	copy + print (2)
<input type="radio"/>	306	print A (total 2)		414	copy + print (1)
<input type="radio"/>	307	print A (L)		501	scan (total 1)
<input type="radio"/>	308	print A (S)			copy scan (total/4)
	309	print (4C1)		502	scan (total 2)
	310	print (4C2)		503	scan (L)
	311	print (Mono1)			copy scan (L/4)
	312	print (Mono2)		504	scan (S)
	313	print (Bk1)			copy scan (S/4)
	314	print (Bk2)	<input type="radio"/>	505	Bk scan (total 1)
	315	print (4C/L)			copy scan (Bk)
	316	print (4C/S)	<input type="radio"/>	506	Bk scan (total 2)
	317	print (Mono/L)	<input type="radio"/>	507	Bk scan (L)
	318	print (Mono/S)			copy scan (Bk/L)
	319	print (Bk/L)	<input type="radio"/>	508	Bk scan (S)
	320	print (Bk/S)			copy scan (Bk/S)
	321	print (4C + Mono/L)		509	color scan (total 1)
	322	print (4C + Mono/S)			copy scan (4C)
	323	print (4C + Mono/2)		510	color scan (total 2)
	324	print (4C + Mono/1)		511	color scan (L)
	325	print (4C/L/double-sided)			copy scan (4C/L)
	326	print (4C/S/double-sided)		512	color scan (S)
	327	print (Mono/L/double-sided)			copy scan (4C/S)
	328	print (Mono/S/double-sided)		513	copy scan (L)
	329	print (Bk/L/double-sided)		514	copy scan (S)
	330	print (Bk/S/double-sided)		515	copy scan (total)

T00-205-02

SERVICE MODE

COPIER>OPTION>USER

Support No.	Counter	Support No.	Counter
<input type="radio"/> 601	box print (total 1)	<input type="radio"/> 703	reception print (L)
<input type="radio"/> 602	box print (total 2)	<input type="radio"/> 704	reception print (S)
<input type="radio"/> 603	box print (L)	<input type="radio"/> 801	report print (total 1)
<input type="radio"/> 604	box print (S)	<input type="radio"/> 802	report print (total 2)
<input type="radio"/> 701	reception print (total 1)	<input type="radio"/> 803	report print (L)
<input type="radio"/> 702	reception print (total 2)	<input type="radio"/> 804	report print (S)

T00-205-03

<CST>

Use it to make cassette-related settings.

U1-NAME U2-NAME U3-NAME U4-NAME	Use it to enable/disable paper name indications in relation to the detection of paper size groups (U1 through U4).
Setting	0: OFF ('U1' through 'U4' indicated on touch panel; default) 1: ON (paper name selected under CST-U1 through CST-U4 indicated)
CST-U1	Use it to select a paper name to be used for paper size group U1.
Setting	22: K-LGL 31: G-LTR (default)
CST-U2	Use it to select a paper name to be used for paper size group U2.
Setting	24: FOOLSCAP (default) 26: OFFICIO 27: E-OFFI 28: B-OFI 33: A-LGL 36: A-OFI 37: M-OFI
CST-U3	Use it to select a paper name to be used for paper size group U3.
Setting	25: A-FLS 34: G-LGL (default) 35: FOLIO
CST-U4	Use it to select a paper name to be used for paper size group U4.
Setting	18: LTR (default) 29: A-LTR

COPIER>OPTION>CST

P-SZ-C1

P-SZ-C2

Use it to select a paper size to be used for the front deck (C1: right deck, C2: left deck).



Select a paper size, and turn off and then on the main power switch.

Setting

6: A4 (default)**15: B5****18: LTR**

<Codes and Paper Notations>

Code	Notation	Name	Code	Notation	Name
01	A1	A1	22	K-LGL	Korean Government
02	A2	A2	23	K-LGLR	Korean Government R
03	A3R	A3R	24	FLSC	FOOLSCAP
04	A3	A3	25	A-FLS	Australian FOOLSCAP
05	A4R	A4R	26	OFI	OFFICIO
06	A4	A4	27	E-OFI	Ecuadorian OFFICIO
07	A5	A5	28	B-OFI	Bolivian OFFICIO
08	A5R	A5R	29	A-LTR	Argentine LETTER
09	B1	B1	30	A-LTRR	Argentine LETTERR
10	B2	B2	31	G-LTR	Government LETTER
11	B3	B3	32	G-LTRR	Government LETTERR
12	B4R	B4R	33	A-LGL	Argentine LEGAL
13	B4	B4	34	G-LGL	Government LEGAL
14	B5R	B5R	35	FOLI	FOLIO
15	B5	B5	36	A-OFI	Argentine OFFICIO
16	11x17	11x17	37	M-OFI	Mexican OFFICIO
17	LTRR	LETTERR	38		
18	LTR	LETTER	39		
19	STMT	STATEMENT	40	ALL	
20	STMTR	STATEMENTR			
21	LGL	LEGAL			

T00-205-04

<ACC>

Use it to make accessory-related settings.

<p>COIN</p> <p>Setting</p>	<p>Use it to turn ON/OFF the coin vendor notation. (not used in copier in question)</p> <p> The 'Control Card Set' notation indicated in the control panel will be replaced with the 'Coin Vendor' notation.</p> <p>0: OFF (default) 1: ON (for coin vendor)</p>
<p>DK-P</p> <p>Setting</p>	<p>Use it to select a paper size to be used for the side paper deck.</p> <p>0: A4 (default) 1: B5 2: LTR</p>

<INT-FACE>

Use it to make settings if an external controller is connected.

<p>IMG-CONT</p> <p>Setting</p>	<p>Use it to enable/disable the external controller detection switch.</p> <p>0: external controller absent (default) 1: external controller present</p>
---------------------------------------	---

2.6 TEST

The following shows the Test screen (COPIER>TEST).

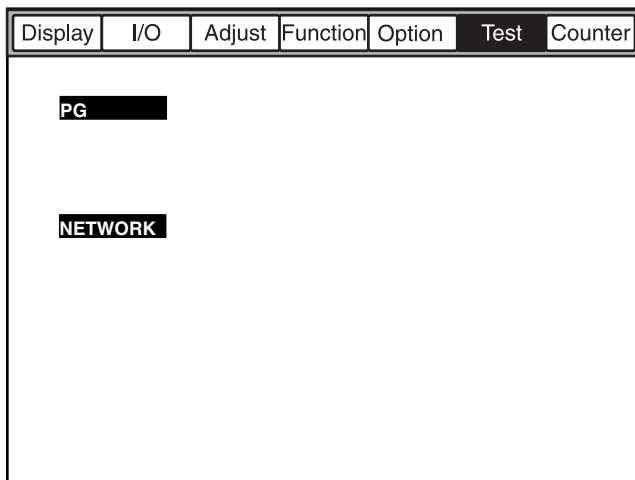

F00-206-01

<PG>

Use it to select a type of test printing and generate it.

TYPE	Select the item, enter the type No. of the test print, and press the Start key to print it out.
Setting	0: normal print, 1 to 9: T00-206-01
TXPH	Use it to switch between text mode and photo mode for test printing.
Setting	0: text mode, 1: photo mode
PG_PICK	Use it to select the source of paper for test printing.
Setting	1: right deck (default), 2: left deck, 3: cassette 3, 4: cassette 4, 5: side paper deck, 6 to 8: not used

<TYPE Input No./Test Print Type>

Input No.	Description	Input No.	Description
0	image from CCD (normal printing)	4	blank
1	grid	5	halftone
2	17 gradations (with image correction)	6	solid black
3	17-gradation (without image correction)	7	vertical straight lines
		8	horizontal straight lines
		9	halftone (for laser delay check)

T00-206-01

1 Grid (PG-TYPE1)

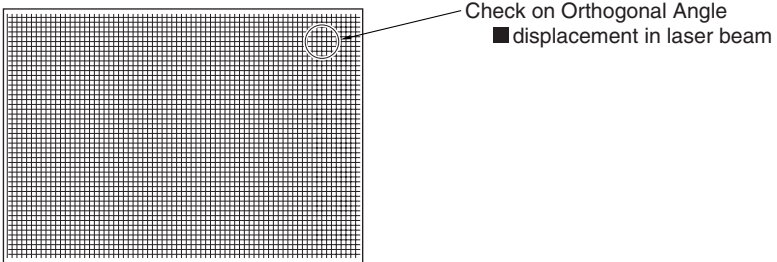

F00-206-02

2 17-Gradation (with image correction; PG-TYPE2)

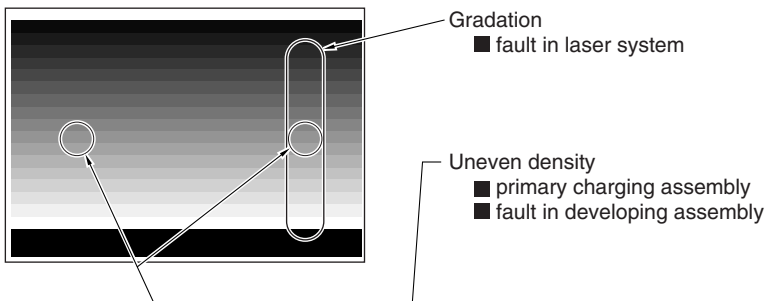

F00-206-03

COPIER>TEST>PG

3 17-Gradation (without image correction; PG-TYPE3)

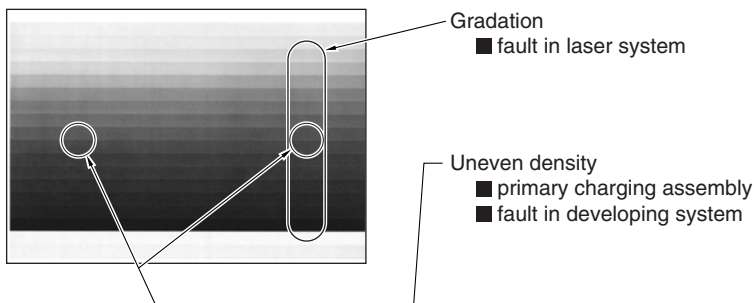

F00-206-04

4 Blank (PG-TYPE4)

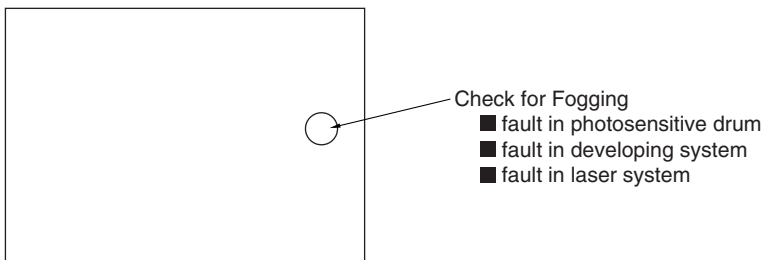

F00-206-05

5 Halftone (PG-TYPE5)

- Halftone Subjected to Density Correction Block (image processing)

In addition to the performance of the image formation system, such density correction mechanisms as AE affect the result.

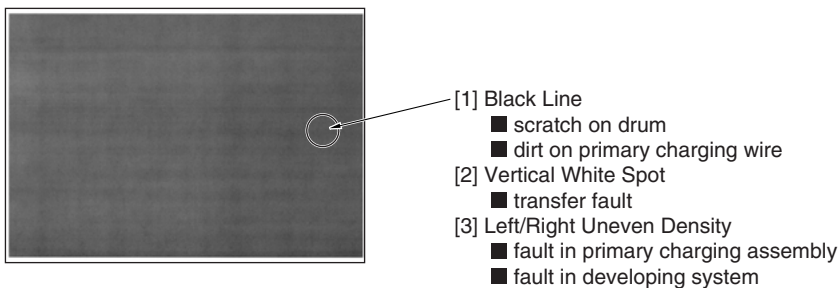

F00-206-06

6 Solid Black (PG-TYPE6)



- [1] White Spot
■ transfer fault
- [2] White Line
■ shading fault
(e.g., dirt on standard white plate)

F00-206-07

7 Vertical Lines (PG-TYPE7)

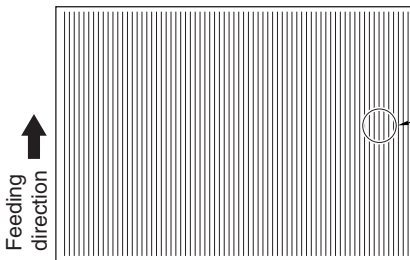

- Straight lines
(sub scanning direction)
■ BD fault

F00-206-08

8 Horizontal Lines (PG-TYPE8)

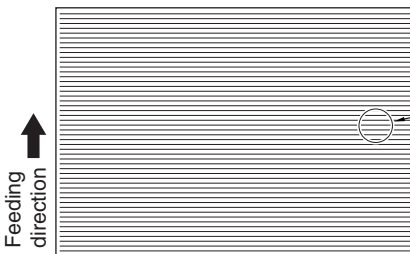

- Straight lines
(main scanning direction)
■ displacement in laser beam

F00-206-09

COPIER>TEST>PG

9 Halftone (for laser delay check; PG-TYPE9)

[A] Laser A scanning Line

[B] Laser B scanning Line

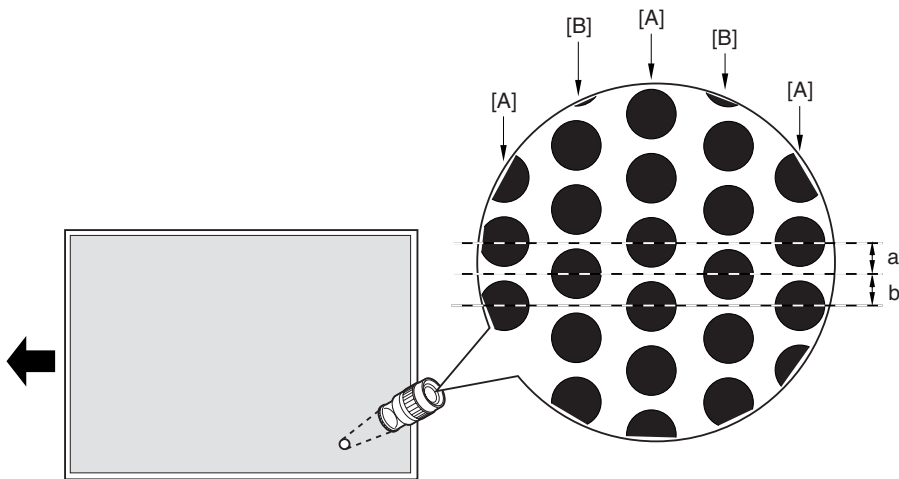

F00-206-10



Laser Delay Check

Use a magnifying glass (CK-0056-000) to make sure that the intervals between a and b in the figure are even; otherwise, adjust the setting using the following: COPIER>ADJUST>LASER>DLY-FINE.

- COPIER.>ADJUST>LASER>DLY-FINE

Range of adjustment: -16 to 16

(in 1/16 pixel; 1 pixel equals to sum of a and b)

<NETWORK>

Use it to check the network-related connections.

PING

Use it to check the connection between the copier and the network (TCP/IP only).



Use to check the connection to the network at time of installation and when a fault occurs when a connection is made to the network.

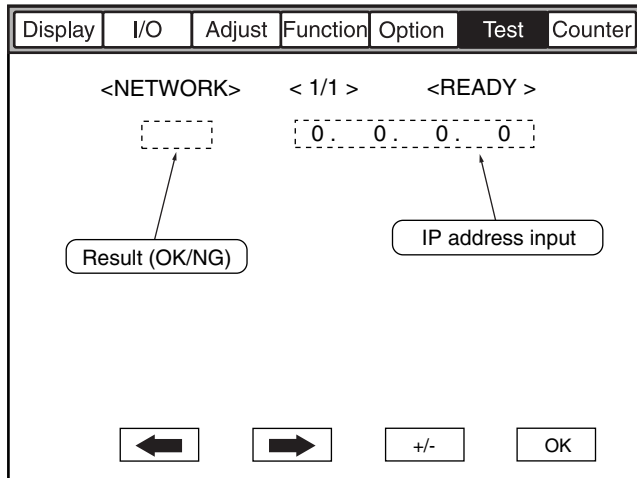

F00-206-11

<Using the Mode>

(at time of installation and connection fault)

- 1) Turn off the main power switch.
- 2) Connect the network cable, and turn on the main power switch.
- 3) Inform the user's system administrator that the copier has been installed, and ask him/her to set up the network.
- 4) Inform the system administrator that you are going to check the network connection, and obtain the remote address (IP address of a PC terminal note user network) from which PING is entered.

COPIER>TEST>NETWORK

- 5) Make the following selections in service mode:
COPIER>TEST>NETWORK>PING. Enter the IP address obtained in step 4); then, press the OK key and then the Start key.
 - If the connection to the network is normal, 'OK' will be indicated. (end of work)
 - If 'NG' is indicated, check the physical connection of the network cable; if normal, go to step 6).
If a fault is found in the network cable connection, correct it, and go to step 5).
- 6) Make the following selections in service mode:
COPIER>TEST>NETWORK>PING. Then, enter the loop-back address* (127.0.0.1); press the OK key and then the Start key.
 - If 'NG' is indicated, suspect a fault in the TCP/IP setting; go back to step 3).
 - If 'OK' is indicated, assume that the sender's TCP/IP is free of a fault. Instead, suspect a fault in the connection of the network interface board (NIC) or on the NIC itself; go to step 7).

* The signal returns without reaching the NIC, enabling a check on the sender's TCP/IP setting.
- 7) Make the following selections in service mode:
COPIER>TEST>NETWORK>PING. Then, enter the load host address (IP address of the sender), and press the OK key.
 - If 'NG' is indicated, suspect a fault in the NIC connector or on the NIC itself; check the connection of the NIC, or replace it.
 - If 'OK' is indicated, assume that the network settings of the sender or the NIC is free of a fault.
In this case, suspect a fault in the network environment: communicate to the system administrator for correction.

2.7 COUNTER

The following shows the Counter screen (COPIER>COUNTER).

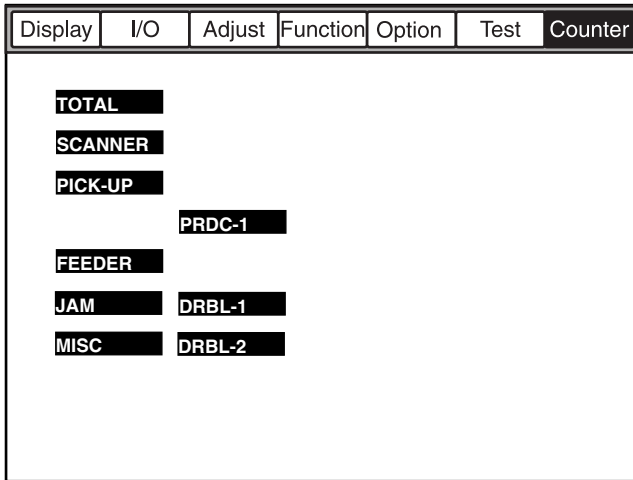

F00-207-01

<Clearing the Counter Reading>

- 1) Select to highlight the item to clear.
- 2) Press the Clear key in the control panel.
 - The counter will be initialized to '00000000'.

<Distinguishing Between Small-Size and Large-Size in the Mode>

Large (L) size: larger than A4, LTR
Small (S) size: A4, LTR or smaller

COPIER>COUNTER

<Guide to the Periodically Replaced Parts and Durables Counters>

The copier is equipped with periodically replaced parts/durables counters (PRDC-1/DRBL-1/DRBL-2), providing estimates for parts replacement.

<EX.>

PRM-WIRE / 00000027 / 00500000 / 0% **!!** 000082
 [1] [2] [3] [4] [5] [6]

- [1] indicates a part name; in the example, the primary charging wire.
- [2] indicates the counter reading (actual number of sheets handled); be sure to press the Clear key to reset the reading.
- [3] indicates the limit (timing of replacement in terms of the number of sheets); use the keypad to change; after making a change, press the OK key.
- [4] indicates the ratio of a counter reading in relation to the limit.
- [5] indicates an exclamation mark (!) if the ratio is between 90% and 100%; 2 marks if 100% or higher; in the example, no mark will be indicated.
- [6] indicates the number of days to the time of replacement; in the example, 82 days.

List of COUNTER Items

Level 1: COUNTER

Mode

Level 2: TOTAL

- Level 3: SERVICE1 total counter 1 for service
- SERVICE2 total counter 2 for service
- COPY copy counter
- PDL-PRT PDL print counter
- RMT-PRT remote copy/print counter
- BOX-PRT Box print counter
- RPT-PRT report print counter
- 2-SIDE double-sided print counter
- SCAN scan counter

Level 2: SCANNER

- Level 3: SC-TTL scanner total scan counter
- SC-STRM scanner stream reading counter
- SC-NRM scanner fixed reading counter

Level 2: PICK-UP

- Level 3: C1 right deck pickup counter
- C2 left deck pick counter
- C3 cassette 3 pickup counter
- C4 cassette 4 pickup counter
- MF manual feed tray pickup counter
- DK side paper deck pickup counter
- 2-SIDE double-sided 2nd side pickup counter

Level 2: FEEDER	
Level 3: FEED	feeder pickup total counter
L-FEED	large size original feeder pickup total counter
S-FEED	small-size original feeder pickup total counter
TTL-MF	manual feed pickup total counter
Level 2: JAM	
Level 3: TOTAL	copier total jam counter
FEEDER	feeder (ADF) jam counter
SORTER	sorter (finisher) jam counter
2-SIDE	duplex jam counter
MF	manual feed tray jam counter
C1	right deck jam counter
C2	left deck jam counter
C3	cassette 3 jam counter
C4	cassette 4 jam counter
DK	side paper deck jam counter
Level 2: MISC	
Level 3: FIX-WEB	fixing web counter (Be sure to clear the reading after replacing the fixing web.)
WST-TNR	waste toner counter (Be sure to clear the reading after disposing of the waste toner.)
R-PD-SEN	right deck pickup sensor
L-PD-SEN	left deck pickup sensor
C3-SEN	cassette 3 pickup sensor
C4-SEN	cassette 4 pickup sensor
SDPD-SEN	deck pickup sensor
RK-F-SEN	right deck draw sensor
LK-F-SEN	left deck draw sensor
VPT3-SEN	vertical path 3 sensor
VPT4-SEN	vertical path 4 sensor
SP-F-SEN	deck feed sensor
Level 2: PRDC-1	
Level 3: PRM-WIRE	primary charging wire counter
PRM-GRID	primary grid wire counter
PO-WIRE	pre-transfer charging wire counter
TR-WIRE	transfer charging wire counter
PRM-CLN	primary charging wire cleaner counter
TR-CLN	transfer charging wire cleaner counter
PO-CLN	pre-transfer charging wire cleaner counter
FIX-TH1	fixing main thermistor (TH1) counter
FIX-TH2	fixing sub thermistor (TH2) counter
FX-TSW	fixing thermal switch (TP1) counter
OZ-FIL1	ozone filter counter
AR-FIL1	air filter counter

COPIER>COUNTER

Level 2: DRBL-1

Level 3: SCN-LMP	scanning lamp activation counter (in sec)
PRE-LMP	pre-exposure lamp activation counter
LSR-DRV	laser drive counter
LSR-MTR	laser scanner motor counter
LSR-FAN	laser motor cooling fan counter
LSR-FAN	laser cooling fan 1 counter
SC-M-FAN	scanner motor cooling fan counter
STRM-FAN	stream reading fan counter
LSR-FAN2	laser cooling fan 2 counter
SCN-MTR	scanner motor counter
PRM-UNIT	primary charging assembly counter
PO-UNIT	pre-transfer charging assembly counter
POST-FAN	pre-transfer charging assembly fan counter
PO-SCRPR	pre-transfer charging assembly scraper counter
TR-UNIT	transfer charging assembly counter
SP-FAN	separation fan counter
P-TR-EXP	pre-transfer exposure lamp counter
SP-FAN	separation heat discharge fan counter
DRM-MTR	drum motor counter
DRM-FAN	drum fan counter
CLN-BLD	cleaner blade counter
SP-CLAW	cleaner separation claw counter
DVG-CYL	developing cylinder counter
DVG-ROLL	developing assembly roll counter
TNR-F-CL	developing assembly magnet roller clutch counter
DEV-1CL	developing cylinder clutch counter
DEV-2CL	developing assembly cylinder clutch counter
TNR-FD-M	toner feed motor counter
VBR-MTR	vibration motor counter
C3-PU-RL	cassette 3 pickup roller counter
C3-SP-RL	cassette 3 separation roller counter
C3-PU-CL	cassette 3 pickup clutch counter
C4-PU-RL	cassette 4 pickup roller counter
C4-SP-RL	cassette 4 separation roller counter
C4-PU-CL	cassette 4 pickup clutch counter
LD-PU-RL	left deck pickup roller counter
LD-SP-RL	left deck separation roller counter
LD-PU-CL	left deck pickup clutch counter
RD-SP-RL	right deck separation roller counter
RD-PU-CL	right deck pickup clutch counter
RD-PU-RL	right deck feed roller counter
M-PU-RL	manual feed tray pickup roller counter
M-SP-RL	manual feed tray separation roller counter

COPIER>COUNTER

M-PU-CL	manual feed tray pickup clutch counter
PICK-MTR	pickup motor counter
REG-CL	registration clutch counter
VP1-CL	vertical path 1 clutch counter
VP2-CL	vertical path 2 clutch count
LD-PL-CL	left deck feed clutch counter
RD-PL-CL	right deck feed clutch counter
C3-PL-CL	cassette 3 feed clutch counter
C4-PL-CL	cassette 4 fee clutch counter
M-PL-CL	manual feed tray pickup clutch counter
FEED-MTR	feed motor counter
REG-B-CL	pre-registration clutch counter
P-R-B-CL	pre-registration brake clutch counter
DL-SW-CL	delivery speed switch-over clutch counter
C3-PU-SL	cassette 3 pickup solenoid counter
C4-PU-CL	cassette 4 pickup solenoid counter
LD-PU-SL	left deck pickup solenoid counter
RD-PU-SL	right deck pickup solenoid counter
M-PU-SL	manual feed tray pickup solenoid counter
RV-FP-SL	reversing flapper solenoid counter
DUP-R-CL	lower feed right clutch counter
DUP-C-CL	lower feed middle clutch counter
DUP-RV-M	duplex reversal motor counter
DUP-FD-M	duplex feed motor counter
DP-FAN	duplex feed fan counter
FX-UP-RL	fixing upper roller counter
FX-LW-RL	fixing lower roller counter
FX-MTR	fixing motor counter
FHTR-M	fixing main heater counter
FHTR-S	fixing sub heater counter
FX-IN-BS	fixing insulating bush counter
FX-FAN	fixing fan counter
FIX-WEB	fixing web counter
FX-BRG-U	fixing upper separation counter
FX-BRG-L	fixing lower bearing counter
DLV-UCLW	delivery upper separation claw counter
DLV-LCLW	delivery lower separation claw counter
CURL-FAN	curl-reducing fan counter
DEV-FAN	developing fan counter
DV-FP-SL	delivery flapper solenoid counter
DLV-FAN	delivery adhesion prevention fan counter
PWS-FAN	power supply fan counter
INV-FAN	inverter cooling fan counter

COPIER>COUNTER

Level 2: DRBL-2

Level 3: DF-PU-RL	ADF pickup roller counter
DF-FD-RL	ADF feed roller counter
PD-PU-RL	side paper deck pickup roller counter
PD-SP-RL	side paper deck separation roller counter
PD-PU-CL	side paper deck pickup clutch counter
PD-PL-CL	side paper deck feed clutch counter
PD-PU-MR	side paper deck pickup motor counter
PD-PU-SL	side paper deck pickup solenoid counter
NON-SORT	non-sort path counter
SORT	sort path counter
FIN-STPR	finisher staple counter
SADDLE	saddle counter
FOLD	folder fold path counter
SDL-STPL	saddle staple counter
PUNCH	punch counter
INSERTER	inserter counter
U-L-PTH1	finisher upper/lower path counter 1
U-L-PTH2	finisher upper/lower path counter 2
SORT-2	finisher lower path counter
INSRTR2	finisher inserter 2 counter
STCK	finisher stack processing counter
SDL-STCK	finisher saddle stack processing counter

3 FEEDER

3.1 DISPLAY

FEEDSIZE

Use it to indicate the size of an original detected by the ADF.

3.2 ADJUST

DOCST

Use it to adjust the original stop position when the ADF is used (original tray pickup).



- A higher value decreases the leading edge margin.
- The data is retained by the ADF controller PCB.

Range of adjustment

-30 to 30 (unit: 0.5 mm)

<Using the Mode>

- 1) Place an original in the original tray.
- 2) Select the item, check the setting, and press the OK key.
- 3) Press the OK key. The original will be picked up.
- 4) Open the ADF, and check the original stop position.
- 5) Press the OK key. The original will be delivered.

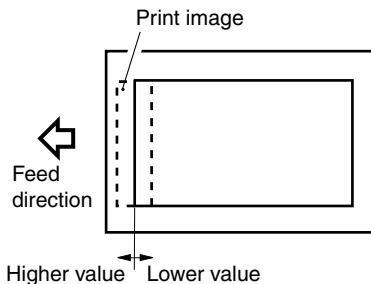

F00-302-01

DOCST-M

Use it to adjust the original stop position when the ADF is used (manual feed tray).

Range of adjustment

-30 to 30 (unit: 0.5 mm)

Using the Mode

Same as in FEEDER>ADJUST>DOCST.

FEEDER>DISPLAY/ADJUST

LA-SPEED

Use it to adjust the original feed speed in ADF stream reading mode.



- A higher value increases the speed.
- The data is retained by the ADF controller PCB.

Range of adjustment

-30 to 30 (unit: 0.1%)

STRD-S

Use it to adjust the scanner stop position for stream reading mode (small-size).

Range of adjustment

-25 to 25 (unit: 0.1 mm)

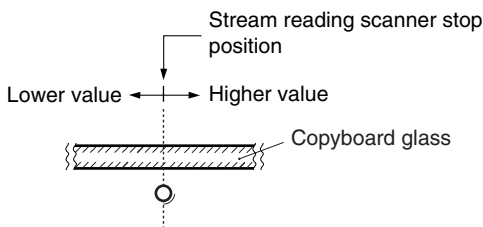

F00-302-02

STRD-L

Use it to adjust the scanner stop position for stream reading mode (large-size).

Range of adjustment

-25 to 25 (unit: 0.1 mm)

<Using the Mode>

Same as in FEEDER>ADJUST>STRD-S.

RVM-SPD

Use it to adjust the speed of the reversal motor.



- A higher value increases the speed.

Range of adjustment

-30 to 30 (unit: 0.1%)

3.3 FUNCTION

SENS-IN	<p>Use it to adjust the sensitivity of each sensor of the ADF.</p> <p> Be sure to clean the sensor first.</p> <p><Using the Mode></p> <ol style="list-style-type: none"> 1) Select the item, and press the OK key. 2) Set that the machine stops automatically after adjustment.
BLT-CLN	<p>Use it to clean the separation belt of the ADF.</p> <p><Using the Mode></p> <ol style="list-style-type: none"> 1) Select the item, and press the OK key. 2) Set that the machine drives the separation belt. Press the Stop key to stop the operation.
REG-CLN	<p>Use it to clean the registration roller of the ADF.</p> <p><Using the Mode></p> <ol style="list-style-type: none"> 1) Select the mode, and press the OK key. 2) Set that the machine rotates the registration roller. Press the Stop key to stop the operation.

FEEDER>OPTION

3.4 OPTION

DOC-F-SW	<p>Use it to turn ON/OFF stream reading mode.</p> <p>0: enable stream reading (default) 1: enable stream reading for small-size only 2: disable stream reading</p>
SIZE-SW	<p>Use to turn ON/OFF detection of a mix of AB and Inch paper sizes.</p> <p>0: disable detection (default) 1: enable detection</p> <p> Detection is enabled only when '3: AB/INCH' is selected under COPIER>OPTION>BODY>MODEL-SZ.</p>
SLW-SPRT	<p>Use it to decelerate the separation speed for original pickup.</p> <p>0: normal mode (default) 1: deceleration mode</p>

4 SORTER

4.1 ADJUST

PNCH-HLE

Use it to adjust the punch hole position (paper feed direction) when the puncher unit is used.



A higher value moves the punch hole toward the leading edge of paper (middle of paper).

Range of adjustment

-23 to 23 (unit: about 0.5 mm)

<Using the Mode>

- 1) Make a print of the Test Chart, and check the position of the holes.
- 2) Select the item, and change the setting to adjust.
- 3) Press the OK key.
- 4) Make a print of the Test Chart once again, and check to see if the position of the holes is as indicated.

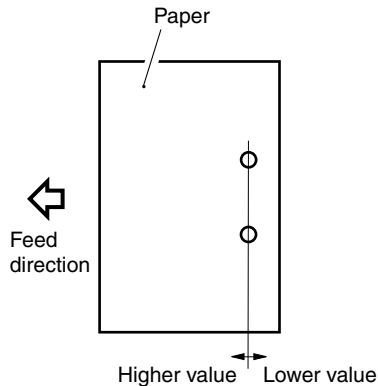

F00-401-01

SORTER>OPTION

4.2 OPTION

BLNK-SW

Use it to set the margin width (W) for both sides of the folding line when the saddle stitcher is used.

Setting

0: normal width (5 mm; default)

1: larger width (10 mm)

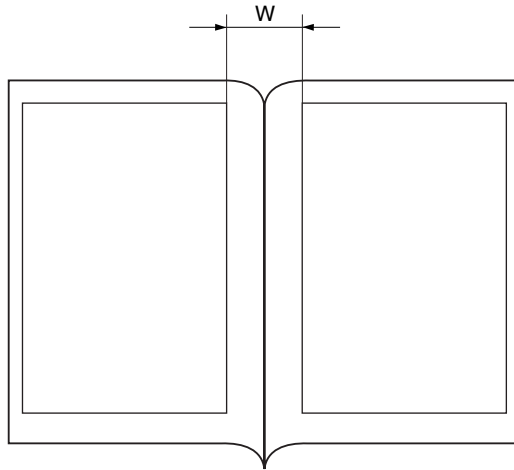

F00-402-01

5 BOARD

5.1 OPTION

MENUE-1	Use it to display Level 1 of the Printer Settings menu. Setting 0: disable display (default) 1: enable display
MENUE-2	Use it to display Level 2 of the Printer Settings menu. Setting 0: disable display (default) 1: enable display
MENUE-3	Use it to display Level 3 of the Printer Settings menu. Setting 0: disable display (default) 1: enable display
MENUE-4	Use it to display Level 4 of the Printer Settings menu. Setting 0: disable display (default) 1: enable display
PCI1-OFF	Use it to turn OFF the function of the slot 1 (PCI) when the board fitted to it goes out of order. Setting 0: normal (default) 1: OFF (do not use board function)
PCI2-OFF	Use it to turn OFF the function of the slot 2 (PCI) when the board fitted to it goes out of order. Setting 0: normal (default) 1: OFF (do not use board function)
PCI3-OFF	Use it to turn OFF the function of the slot 3 (PCI) when the board fitted to it goes out of order. Setting 0: normal (default) 1: OFF (do not use the board function)

Error Code

1 Error Codes

1.1 Outline of Error Codes

The CPU on the machine's main controller PCB and DC controller PCB is equipped with a self diagnostic mechanism that monitors the condition of the machine (especially of the sensors); upon detection of a fault, it indicates the fact in the control panel using an error code.

A description of each code and the timing of its detection are as discussed hereafter; the suffix that may follow each code is a detail code, which may be checked in service mode (COPIER>DISPLAY>JAM/ERR).

The error codes are grouped as follows according to the items they refer to:

E000 to E399	error code related to the copier
E400 to E499	error code related to the ADF
E500 to E514	error code related to the finisher
E515	error code related to the inserter
E518	error code related to the paper folding unit
E530 to E595	error code related to the finisher
E5F0 to E5F9	error code related to the saddle stitch assembly
E601 to E830	error code related to the copier



When the self diagnostic mechanism has gone ON, the machine may be reset by turning its power switch. This, however, does not apply to E000, E001, E002, E003, E004, E005, E013, E020, or E717, indicating a fault which can lead to serious consequences if the machine is reset without removing the cause (i.e., melting thermistor, which will overheat the fixing roller, or overflowing of toner from the hoper).

If the code is from E000 to E003, the power switch will go OFF in about 30 sec if it is turned ON without resetting; in the case of E004, the power switch will go OFF in about 3 sec after indicting E000 if the power switch is turned ON without resetting.

You will have to clear the data in the RAM on the DC controller PCB for the following: E000, E001, E002, E003, E004, E005, E013, E020, and E717.

<Clearing Errors>

- 1) Execute the following in service mode: COPIER>FUNCTION>CLEAR>ERR.
- 2) Press the Reset key twice to return to the Copy Mode screen.
- 3) Turn off and the on the main power switch.

- Copier (from E000 to E399)

E000

Main cause	The main thermistor (TH1) has poor contact or an open circuit. The thermal switch (TP1) has an open circuit. The fixing heater has an open circuit. The SSR is faulty. The DC controller PCB is faulty.
Condition	<p>0000 When the main power switch is turned on, the reading of the main thermistor does not reach 70°C within 3 min 30 sec.</p> <p>0010 The power is turned off and then on without clearing the error.</p>
Caution	You must clear the error in service mode (COPIER>FUNCTION>CLEAR>ERR).

E001

Main cause	The main thermistor (TH1) has a short circuit. The sub thermistor (TH2) detects overheating. The SSR is faulty. The DC controller PCB is faulty.
Condition	<p>0001 The hardware port detects a fault.</p> <p>0002 Either the main thermistor or the sub thermistor detects 230°C or higher for 2 sec.</p> <p>0003 The reading of the main thermistor is higher than that of the sub thermistor by 50°C or more for 1 sec.</p> <p>0004 The reading of the main thermistor is lower than that of the sub thermistor by 50°C or more for 1 sec.</p> <p>0010 The power is turned off and then on without clearing the error.</p>
Caution	You must clear the error in service mode (COPIER>FUNCTION>CLEAR>ERR).

E002	
Main cause	The main thermistor (TH1) has poor contact or an open circuit. The thermal switch (TP1) has an open circuit. The fixing heater has an open circuit. The SSR is faulty. The DC controller PCB is faulty.
Condition	<p>0000 The reading of the main thermistor (TH1) does not reach 100°C 2 min 30 sec after it has exceeded 70°C.</p> <p>0001 The reading of the main thermistor does not reach 150°C within 2 min 30 sec after it has exceeded 100°C.</p> <p>0010 The power has been turned off and then on without clearing the error.</p>
Caution	You will have to clear the error in service mode (COPIER>FUNCTION>CLEAR>ERR).
E003	
Main cause	The main thermistor (TH1) has poor contact or an open circuit. The thermal switch (TP1) has an open circuit. The fixing heater has an open circuit. The SSR is faulty. The DC controller PCB is faulty.
Condition	<p>0000 The reading of the main thermistor is 70°C or lower for 2 sec or more after it has reached 100°C.</p> <p>0010 The power has been turned off and then on without clearing the error.</p>
Caution	You will have to clear the error in service mode (COPIER>FUNCTION>CLEAR>ERR).
E004	
Main cause	The SSR has a short circuit. The DC controller PCB is faulty.
Condition	<p>0000 The SSR used to drive the fixing heater has a short circuit (detection by hardware circuitry).</p>
Caution	You will have to clear the error in service mode (COPIER>FUNCTION>CLEAR>ERR).

<p>E005</p> <p>Main cause</p> <p>Condition</p> <p>Caution</p>	<p>The fixing web has been taken up. The fixing web length sensor (PS7) is faulty. The DC controller PCB is faulty.</p> <p>0000 The length of the fixing web that has been taken up is more than a specific value and the fixing web length sensor (PS7) has detected the absence of the web for 5 sec or more.</p> <p>0010 The power is turned off and then on without clearing the error.</p> <p>After replacing the fixing web, you will have to clear the two web counters in service mode (COPIER>COUNTER>MISC>FIX-WEB and COPIER>COUNTER>DRBL-1>FIX-WEB).</p>
<p>E010</p> <p>Main cause</p> <p>Condition</p>	<p>The main motor (M1) is faulty. The DC controller PCB is faulty.</p> <p>0000 No clock pulse arrive for 2 sec or more after the main motor drive signal (MMFG) has been generated.</p>
<p>E012</p> <p>Main cause</p> <p>Condition</p>	<p>The drum motor (M0) is faulty. The DC controller PCB is faulty.</p> <p>0000 No clock pulse arrives for 2 sec or more after the drum motor drive signal (DMFG) has been generated.</p>
<p>E013</p> <p>Main cause</p> <p>Condition</p>	<p>The waste toner feedscrew is faulty. The waste toner clog detecting switch (MSW2) is faulty. The DC controller PCB is faulty.</p> <p>0000 The waste toner feedscrew fails to rotate normally, and the switch MSW2 is pressed multiple times within a specific period of time.</p> <p>0010 The power is tuned off and then on without clearing the error.</p>
<p>E014</p> <p>Main cause</p> <p>Condition</p>	<p>The fixing motor (M3) is faulty. The DC controller PCB is faulty.</p> <p>0000 The motor clock signal is not detected for 2 sec or more after the fixing motor drive signal has been generated.</p>

<p>E015</p> <p>Main cause Condition</p>	<p>The pickup motor (M2) is faulty. The DC controller PCB is faulty.</p> <p>0000 The motor lock signal is not detected for 2 sec or more after the pickup motor drive signal has been generated.</p>
<p>E019</p> <p>Main cause Condition</p>	<p>The waste toner case is full. The waste toner case full sensor (PS19) is faulty. The DC controller PCB is faulty.</p> <p>0000 More than a specific number of pages are printed without disposing of the waste toner after the waste toner case has been found to be full.</p>
<p>E020</p> <p>Main cause Condition</p>	<p>The hopper connector is disconnected. The toner feed motor (M18) inside the hopper is faulty. The magnet roller drive clutch (CL1) inside the hopper is faulty. The toner sensor (TS3) inside the developing assembly is faulty. The DC controller PCB is faulty.</p> <p>0000 Although the developing assembly is supplied with toner, the absence of toner inside it is detected for 3 sec or more.</p> <p>0010 The power is turned off and then on without clearing the error.</p>
<p>E025</p> <p>Main cause Condition</p>	<p>The toner feed motor (M6) inside the cartridge is faulty. The DC controller PCB is faulty.</p> <p>0000 The DC controller PCB detects an overcurrent flowing to the toner feed motor (M6) inside the cartridge for 10 sec or more twice. (In response to the first detection, it indicates the message "Shake the Toner Case, and Set.")</p>

E032	
Main cause	The copy data controller or the NE controller is faulty. The main controller PCB is faulty.
Condition	0000 The copy data controller or the NE controller are disconnected after they have once been connected.
E043	
Main cause	The side paper deck main motor (M101) is faulty. The side deck driver PCB is faulty. The DC controller PCB is faulty.
Condition	0000 The PLL lock signal (DMPLK) does not arrive for 2 sec or more after the side paper deck main motor drive signal has been generated.
E051	
Main cause	The horizontal registration sensor (PS18) is faulty. The horizontal registration motor (M15) is faulty. The DC controller PCB is faulty.
Condition	0001 Departure from home position is not detected within 5 sec during a horizontal registration home position search. 0002 Home position is not detected within 5 sec during a horizontal registration home position search. 0003 The horizontal registration detection movement for the preceding sheet does not end within 5 sec at the start of a horizontal registration search during printing.
E065	
Main cause	The primary charging assembly is faulty. The HV-DC PCB is faulty. The wiring is faulty (short circuit, open circuit).
Condition	0000 An error (leakage) is detected in the high-voltage output to the primary charging assembly.

E067	
Main cause	The HV-DC PCB is faulty. The HV-AC PCB is faulty. The wiring is faulty (short circuit, open circuit).
Condition	0000 An error is detected in two or more of the following at the same time: the primary high voltage, pre-transfer high voltage, transfer high voltage, and separation high voltage. Or, an error (leakage) in the high-voltage output to the separation charging assembly is detected.
E068	
Main cause	The HV-DC PCB is faulty. The HV-AC PCB is faulty. The separation charging assembly is faulty. The wiring is faulty (short circuit, open circuit).
Condition	0000 An error (leakage) to the high-voltage output to the separation charging assembly is detected.
E069	
Main cause	The HV-DC PCB is faulty. The HV-AC PCB is faulty. The transfer charging assembly is faulty. The wiring is faulty (short circuit, open circuit).
Condition	0000 An error (leakage) is detected in the high-voltage output to the transfer charging assembly.
E100	
Main cause	The BD PCB is faulty. The DC controller PCB is faulty. The laser unit is faulty. The laser driver PCB 1 is faulty. The laser driver PCB 2 is faulty. The wiring is faulty (short circuit, open circuit).
Condition	0000 The BD signal does not arrive within 1 sec after the laser drive signal has been generated. Or, the BD signal does not arrive for 1 sec or more while the laser remains ON.

E110	
Main cause	The laser scanner motor (M4) is faulty. The laser scanner drive PCB is faulty. The wiring is faulty (short circuit, open circuit). The DC controller PCB is faulty.
Condition	0000 The constant speed rotation signal (LM-RDY) does not arrive for 20 sec or more after the laser scanner motor (M4) drive signal has been generated.
E111	
Main cause	The laser motor cooling fan (FM1) is faulty. The DC controller PCB is faulty. The wiring is faulty (short circuit, open circuit).
Condition	0000 The lock signal arrives for 5 sec or more although the laser motor cooling fan (FM1) is being driven.
E121	
Main cause	The laser cooling fan 1 (FM3) or the laser cooling fan 2 (FM5) is faulty. The DC controller PCB is faulty. The wiring is faulty (short circuit, open circuit).
Condition	0001 The lock signal arrives for 5 sec or more although the laser cooling fan 1 (FM3) is being driven. 0002 The lock signal arrives for 5 sec or more although the laser cooling fan 2 (FM5) is being driven.
E202	
Main cause	The scanner HP sensor (PS1) is faulty. The scanner motor (M5) is faulty. The reader controller PCB is faulty. The copyboard glass is displaced.
Condition	0000 Scanner home position cannot be detected within a specific period of time after the power switch is turned on or the Start key is pressed.
Caution	No code will be indicated. The keys will be locked. You can check the code in service mode (COPIER>DISPLAY>ERR).

E204	
Main cause	The scanner motor (M5) is faulty. The image leading edge sensor (PS3) is faulty. The ADF controller PCB is faulty. The reader controller PCB is faulty.
Condition	0000 During forward movement in fixed reading mode or during a home position search, the image leading signal does not occur; or, in stream reading mode, the image leading edge signal does not arrive from the ADF controller PCB.
Caution	No code will be indicated. The keys will be locked. You can check the code in service mode (COPIER>DISPLAY>ERR).
E211	
Main cause	The thermistor (TH3) inside the fluorescent lamp heater is faulty. The light adjustment control PCB is faulty. The reader controller PCB is faulty. The wiring is faulty (short circuit, open circuit).
Condition	0000 While the power is ON, the ambient temperature of the fluorescent lamp does not exceed 10°C 2 min after the florescent heater has gone ON; or, after the power is turned on, the reading of the ambient temperature of the fluorescent lamp is 0°C or lower.
E215	
Main cause	The thermistor (TH3) inside the fluorescent heater has a short circuit. The light adjustment control circuit is faulty. The reader controller PCB is faulty. The wiring is faulty (short circuit, open circuit).
Condition	0000 While the fluorescent lamp is OFF, the reading of the ambient temperature is 170°C or higher.
E218	
Main cause	The fluorescent lamp is not mounted properly.
Condition	0000 When the power is turned on, the absence of the fluorescent lamp is detected.

E219	
Main cause	The fluorescent lamp has reached the end of its life. The thermistor (TH3) inside the fluorescent lamp is faulty.
Condition	0000 While the fluorescent lamp is ON, the reading of the ambient temperature is 170°C or higher.
E220	
Main cause	The fluorescent lamp is faulty. The light adjustment sensor is faulty. The light adjustment control PCB is faulty. The inverter PCB is faulty. The reader controller PCB is faulty.
Condition	0000 The fluorescent lamp does not reach a specific intensity within 10 sec after it is tuned on (if the room temperature is 10°C or lower, within 60 sec). Or, the ON detection signal (FL-DTCT) does not go OFF within 5 sec after the fluorescent lamp is turned off; during shading adjustment, the ON detection signal (FL-DTCT) does not go ON within 60 sec after the fluorescent lamp is turned on.
E222	
Main cause	The lamp heater (H5) is faulty. The light adjustment control PCB is faulty. The reader controller PCB is faulty. The wiring is faulty (short circuit, open circuit).
Condition	0000 During the initial activation after power-on, the reading does not reach 70°C within 5 min after the heater is turned on. Or, during standby or reading operation, the reading does not reach 75°C within 3 min after the heater is tuned on.
E226	
Main cause	The scanner cooling fan is faulty.
Condition	0000 The scanner cooling fan stop signal is detected for 5 sec or more although the scanner cooling fan is being driven.

<p>E240</p> <p>Main cause</p> <p>Condition</p>	<p>The main controller PCB is faulty. The DC controller PCB is faulty. The wiring is faulty (short circuit, open circuit).</p> <p>0000 A communication fault exists between the CPUs of the main controller PCB and the DC controller PCB.</p>
<p>E241</p> <p>Main cause</p> <p>Condition</p>	<p>The original orientation detection PCB is faulty. The wiring is faulty (short circuit, open circuit). The reader controller PCB is faulty.</p> <p>0000 The initial communication between the CPUs of the original orientation detection PCB and the reader controller PCB fails.</p> <p>0001 When the orientation of an original is detected, the result of detection is not communicated by the original orientation detection PCB until the next original is read.</p> <p>0002 The result of detection of the last original is not communicated 5 sec after the end of reading the last original.</p>
<p>E243</p> <p>Main cause</p> <p>Condition</p>	<p>The control panel CPU PCB is faulty. The main controller PCB is faulty.</p> <p>0000 A communication fault exists between the CPUs of the control panel CPU PCB and the main controller PCB.</p>
<p>E251</p> <p>Main cause</p> <p>Condition</p>	<p>The inverter cooling fan (FM9) is faulty. The wiring is faulty (short circuit, open circuit). The read controller PCB is faulty.</p> <p>0000 The lock signal (FM9LCK) arrives for 5 sec or more although the inverter cooling fan (FM9) is being driven.</p>
<p>E302</p> <p>Main cause</p> <p>Condition</p>	<p>The CCD/AP PCB is faulty. The wiring is faulty (short circuit, open circuit). The reader controller PCB is faulty.</p> <p>0000 During shading operation, the reader controller PCB fails to end shading processing.</p>

E315

Main cause
Condition

The reader controller PCB is faulty. The main controller PCB is faulty.

0000 During image rotation, the encoding/decoding has a fault.

E320

Main cause
Condition

The CCD/AP PCB is faulty. The wiring is faulty (short circuit, open circuit). The reader controller PCB is faulty.

0000 While an image is being read, the image read end notice does not arrive at the reader controller PCB within 60 sec from the CCD/AP PCB.

- ADF (from E400 to E420)

E400	
Main cause	The communication cable between ADF and copier is faulty. The ADF controller PCB is faulty.
Condition	0000 While the ADF is in standby, the communication between ADF and copier is interrupted for 5 sec or more. Or, when the ADF is in operation, the communication between ADF and copier is disrupted for 0.5 sec or more.
E402	
Main cause	The belt motor (M2) inside the ADF is faulty. The belt motor clock sensor (PI1) is faulty. The ADF controller PCB is faulty.
Condition	0000 The clock signal does not occur for 100 msec when the belt motor drive signal is generated.
E404	
Main cause	The delivery motor (M5) is faulty. The delivery motor clock sensor (PI11) is faulty. The ADF controller PCB is faulty.
Condition	0000 The clock signal does not occur for 200 msec when the delivery motor drive signal is generated.
E405	
Main cause	The separation motor (M4) is faulty. The separation motor clock sensor (PI2) is faulty. The ADF controller PCB is faulty.
Condition	0000 The clock signal does not occur for 200 msec when the separation motor drive signal is generated.

E410	
Main cause	The pickup motor (M3) is faulty. The pickup roller height sensor 1 (PI8) is faulty. The pickup roller height sensor 2 (PI9) is faulty. The pickup roller home position sensor (PI7) is faulty. The ADF controller PCB is faulty.
Condition	0000 The pickup roller height sensor 1 (PI8) or 2 (PI9) does not generate a signal within 2 sec after the pickup motor is driven. Or, the pickup roller home position sensor (PI7) does not generate a signal within 2 sec after the pickup motor is driven.
E412	
Main cause	The cooling fan (FM1) is faulty. The ADF controller PCB is faulty.
Condition	0000 The lock signal arrives for 100 msec or more although the cooling fan is being driven.
E420	
Main cause	The EEPROM is faulty. The ADF controller PCB is faulty.
Condition	0000 The backup data of the EEPROM cannot be read when the connected device is tuned on. Or, the data that has been read has a fault.
Caution	If the self diagnostic mechanism of the ADF has gone ON, the error may be cleared by turning off and then on the connected device. While the ADF remains out of order, printing may be continued by disconnecting the lattice connector of the ADF, opening the ADF, and placing the original on the copyboard glass.

- Finisher (from E500 to E514)

E500

Main cause	The finisher controller PCB is faulty (data communication with the copier). The DC controller PCB is faulty.
Condition	0000 The communication between copier and finisher is disrupted and, in addition, is not recovered despite retransmission for 5 sec. The disruption and the recovery have been repeated three times in 5 sec. (This error is detected by the finisher.)

E501

Main cause	The finisher controller PCB is faulty (data communication with the slave CPU).
Condition	0000 The communication between the master CPU (IC106) and the slave CPU (IC125) is disrupted.

E503

Main cause	The saddle sticher controller PCB is faulty. The finisher controller PCB is faulty (data communication with the saddle).
Condition	0000 The communication between saddle sticher controller PCB and the finisher controller PCB is disrupted.

E505

Main cause	The EEPROM is faulty. The finisher controller PCB is faulty. The punch driver PCB is faulty.
Condition	0001 The checksum of the EEPROM is faulty (offset value error of the aligning plate). 0002 The checksum of the EEPROM is faulty (D/A conversion value error of the motor drive or sensor adjustment value).

E506	<p>Downloading to the built-in flash of the slave CPU (IC125) is faulty.</p>
<p>Main cause Condition</p>	<p>0001 error in serial communication for data transfer 0002 error in flash memory write operation (write not possible) 0003 error in transfer of user program (checksum mismatch) 0004 error in transfer of slave program (checksum mismatch) 0005 As long as 3 min has passed without operation after a shift to download mode, or start-up is executed without finishing downloading.</p>
E510	<p>The inlet motor (M1) is faulty. The finisher controller PCB is faulty.</p>
<p>Main cause Condition</p>	<p>00FF A condition is detected for 1 sec or more in which the clocks from the inlet motor are 50 mm/sec or less while the motor is in operation.</p>
E514	<p>The stack delivery motor (M7) is faulty. The stack delivery motor clock sensor (PI12) is faulty. The finisher controller PCB is faulty.</p>
<p>Main cause Condition</p>	<p>00FF A condition is detected for 1 sec or more in which the clocks from the stack delivery motor clock sensor is 50 mm/sec or less while the motor is in operation.</p>
<p>• Inserter (E515)</p>	
E515	<p>The inserter motor clock sensor (PI42) is faulty. The inserter motor (M15) is faulty. The inserter drive PCB is faulty.</p>
<p>Main cause Condition</p>	<p>00FF The clocks from the inserter motor drop below a specific value while the motor is in operation.</p>

• Paper Deck Folding Unit (E518)

E518

Main cause
Condition

The folder motor (M14) is faulty. The folder driver PCB is faulty.

00FF The clocks from the folder motor drop below a specific value while the motor is in operation.

• Finisher (from E530 to E595)

E530

Main cause
Condition

The rear aligning plate home position sensor (PI9) is faulty. The rear alignment motor (M5) is faulty. The finisher controller PCB is faulty.

0001 The aligning plate does not return to home position when the rear aligning plate motor is driven for a specific period of time.
0002 The aligning plate does not leave home position when the rear aligning plate motor is driven for a specific period of time.

E531

Main cause
Condition

The stapling home position sensor (inside the stapler) is faulty. The stapler motor (M11) is faulty. The swing guide safety switch (MSW2) is faulty. The stapler safety switch (front; MSW6) is faulty. The stapler safety switch (rear; MSW7) is faulty. The finisher controller PCB is faulty.

0001 The stapler does not return to stapling home position when the stapler motor is driven for 0.5 sec.
0002 The stapler does not leave stapling home position when the stapler motor is driven for 0.5 sec.

E532

Main cause
Condition

The stapler shift home position sensor (PI16) is faulty. The stapler shift motor (M10) is faulty. The swing guide safety switch (MSW2) is faulty. The stapler safety switch (front; MSW6) is faulty. The stapler safety switch (rear; MSW7) is faulty. The finisher controller PCB is faulty.

0001 The stapler does not return to stapler shift home position when the stapler shift motor is driven for 4 sec.
0002 The stapler does not leave stapler shift home position when the stapler shift motor is driven for 4 sec.

E535

Main cause The swing guide open sensor (PI15) is faulty. The swing guide closed sensor (P14) is faulty. The swing motor (M8) is faulty. The finisher controller PCB is faulty.

Condition

- 0001 The swing guide closed sensor does not go ON when the swing motor is driven for 2 sec.
- 0002 The swing guide open sensor does not go ON when the swing motor is driven for 1 sec.

E537

Main cause The front aligning plate home position sensor (PI7) is faulty. The front aligning plate motor (M4) is faulty. The finisher controller PCB is faulty.

Condition

- 0001 The aligning plate does not return to home position when the front aligning plate motor is driven for 4 sec.
- 0002 The aligning plate does not leave home position when the front aligning plate motor is driven for 4 sec.

E540

Main cause The tray A lift motor (M13) is faulty. The tray A idle rotation sensor (PI19) is faulty. The tray A paper sensor (PI 20) is faulty. The tray approach switch (MSW3) is faulty.

Condition

- 0001 clock error (The click from the tray A idle rotation sensor is disrupted for 250 msec when the motor is rotating.)
- 0002 area error (The position of the tray A is found to be below the area of the tray B.)
- 0003 safety switch error
- 0004 time-out (The ascent/decent operation does not end within 25 sec when the tray A lift motor is driven.)

E542

Main cause	The tray B lift motor (M12) is faulty. The tray B idle rotation sensor (PI18) is faulty. The tray B lower limit sensor (PI24) is faulty. The tray B paper sensor (PI17) is faulty.
Condition	<p>0001 clock error (The clock from the tray B idle rotation sensor is disrupted for 250 msec whether motor is rotating.)</p> <p>0002 area error (The position of the tray B is found to be above the area of the tray A.)</p> <p>0003 safety switch error</p> <p>0004 time-out (The ascent/descent operation does not end within 25 sec when the tray B lift motor is driven.)</p>

E551

Main cause	Power supply fan (FM1) is faulty. The feeder cooling fan (FM2) is faulty.
Condition	<p>0001 The power supply fan is at rest for 2 sec or more.</p> <p>0002 The feeder cooling fan is at rest for 2 sec or more.</p>

E577

Main cause	The paddle motor (M9) is faulty. The paddle home position sensor (PI14) is faulty.
Condition	0001 The paddle home position sensor does not detect the paddle within 5 sec after the motor is driven.

E578

Main cause	The knurled belt motor (M20) is faulty. The knurled belt home position sensor (PI34) is faulty.
Condition	<p>0001 The knurled belt motor does not return to home position when the knurled belt motor is driven for 1 sec or more.</p> <p>0002 The knurled belt does not leave home position when the knurled belt motor is driven for 1 sec or more.</p>

E583	
Main cause	The tray sub plate motor (M6) is faulty. The tray retraction sensor (PI11) is faulty.
Condition	<p>0001 The tray sub plate retraction sensor does not go ON a specific period of time after the tray sub plate motor is driven.</p> <p>0002 The tray sub plate retract sensor does not go OFF a specific period of time after the tray sub plate motor is driven.</p>
E584	
Main cause	The paddle motor (for driving the shutter; M9) is faulty. The shutter home position sensor (PI12) is faulty.
Condition	<p>0001 The shutter does not return to home position when the paddle motor is driven for 1 sec or more.</p> <p>0002 The shutter does not leave home position when the paddle motor is driven for 1 sec or more.</p>
E590	
Main cause	The punch home position sensor (PI24) is faulty. The punch 2/3-home sheet sensor (PI33) is faulty. The punch motor clock sensors (PI34) is faulty. The punch motor (M18) is faulty. The punch driver PCB is faulty.
Condition	<p>0001 The puncher does not return to home position when the punch motor is driven for a specific period of time.</p> <p>0002 The puncher does not leave home position when the punch motor is driven for a specific period of time.</p> <p>0003 The braking start position of the punch motor is faulty.</p> <p>0004 The puncher is not at home position at the time of a 5-hole sheet switch-over (2/3-hole sheet puncher only).</p>

<p>E593</p> <p>Main cause</p> <p>Condition</p>	<p>The slider home position sensor (PI22) is faulty. The punch registration motor (M17) is faulty. The punch driver PCB is faulty.</p> <p>0001 The puncher does not return to horizontal registration home position when the punch registration motor is driven for a specific period of time.</p> <p>0002 The puncher does not leave horizontal registration home position when the punch registration motor is driven for a specific period of time.</p>
<p>E594</p> <p>Main cause</p> <p>Condition</p>	<p>The punch sensor home position sensor (PI23) is faulty. The punch sensor slide motor (M19) is faulty. The punch driver PCB is faulty.</p> <p>0001 The punch paper edge sensor (PI21) does not return to home position when the punch sensor slide motor is driven for a specific period of time.</p> <p>0002 The punch paper edge sensor (PI21) does not leave home position when the punch sensor slide motor is driven for a specific period of time.</p>
<p>E595</p> <p>Main cause</p> <p>Condition</p>	<p>The punch waste paper feed motor (M16) is faulty. The punch waste paper feed sensor (PI27) is faulty. The punch driver PCB is faulty.</p> <p>0000 The input from the punch waste paper feed sensor does not change when the punch waste paper feed motor is driven.</p>

- Saddle Stitcher (from E5F0 to E5F9)

E5F0

Main cause

The paper positioning plate home position sensor (PI49) is faulty. The paper positioning plate motor (M44) is faulty. The saddle stitcher controller PCB is faulty.

Condition

- 0001 The paper position plate home position sensor does not go ON when the paper position plate motor is driven for 1.25 sec or more.
- 0002 The paper positioning plate home position sensor does not go OFF when the paper position plate motor is driven for 1 sec or more.

E5F1

Main cause

The fold motor clock sensor (PI47) is faulty. The paper fold motor (M42) is faulty. The saddle stitcher controller PCB is faulty.

Condition

- 0001 The number of detection pulses of the fold motor clock sensor drops below a specific value.

E5F2

Main cause

The guide home position sensor (PI54) is faulty. The guide motor (M43) is faulty. The saddle stitcher controller PCB is faulty.

Condition

- 0001 The guide home position sensor does not go ON when the guide motor is driven for 0.4 sec or more.
- 0002 The guide home position sensor does not go OFF when the guide motor is driven for 1 sec or more.

E5F3

Main cause

The aligning plate home position sensor (PI48) is faulty. The alignment motor (M45) is faulty. The saddle stitcher controller PCB is faulty.

Condition

- 0001 The aligning plate home position sensor does not go ON when the alignment motor is driven for 0.5 sec or more.
- 0002 The alignment plate home position sensor does not go OFF when the alignment motor is driven for 1 sec or more.

E5F4	
Main cause	The saddle rear stapler home position switch (MS32) is faulty. The saddle rear stapler motor (M46) is faulty. The saddle stitcher controller PCB is faulty.
Condition	<p>0001 The saddle rear stapler home position switch does not go ON when the saddle rear stapler motor is driven clockwise for 0.5 sec or more.</p> <p>0002 The saddle rear stapler home position switch does not go OFF when the saddle rear stapler motor is driven counterclockwise for 0.5 sec or more.</p>
E5F5	
Main cause	The saddle front home position switch (MS34) is faulty. The saddle front motor (M47) is faulty. The saddle stitcher controller PCB is faulty.
Condition	<p>0001 The saddle front home position switch does not go ON when the saddle front motor is driven clockwise for 0.5 sec or more.</p> <p>0002 The saddle front home position switch does not go OFF when the saddle front motor is driven counterclockwise for 0.5 sec or more.</p>
E5F6	
Main cause	The paper pushing plate motor clock sensor (PI45) is faulty. The paper pushing plate leading edge sensors (PI56) is faulty. The paper pushing plate home position sensor (PI55) is faulty. The paper pushing plate motor (M48) is faulty. The saddle stitcher controller PCB is faulty.
Condition	<p>0001 The paper pushing plate home position sensor does not go ON when the paper pushing plate motor is driven for 0.3 sec or more.</p> <p>0002 The paper pushing plate home position sensor does not go OFF when the paper pushing plate motor is driven for 0.3 sec or more.</p> <p>0003 The paper pushing plate leading edge sensor does not go OFF when the paper pushing plate motor is driven for 0.3 sec or more.</p> <p>0004 The number of detection pulses of the paper pushing plate motor drops below a specific value.</p>

E5F7	
Main cause	The saddle tray motor (M49) is faulty. The saddle tray home position sensor (PI41) is faulty. The saddle stitcher controller PCB is faulty.
Condition	<p>0001 The saddle tray home position sensor does not go ON when the saddle motor is driven for 8 sec or more.</p> <p>0002 The saddle tray home position sensor does not go OFF when the saddle tray motor is driven for 1 sec or more.</p>
E5F8	
Main cause	The guide home position sensor (PI54) is faulty. The paper pushing plate home position sensor (PI55) is faulty. The paper pushing plate leading edge position sensor (PI56) is faulty. The saddle stitcher controller PCB is faulty.
Condition	<p>0001 The connector of the guide home position sensor is disconnected.</p> <p>0002 The connector for the paper pushing plate home position sensor is disconnected.</p> <p>0003 The connector of the paper pushing plate lading edge sensor is disconnected.</p>
E5F9	
Main cause	The inlet cover open/closed sensor (PI51) is faulty. The outlet cover open sensor (PI46) is faulty. The saddle stitcher controller PCB is faulty.
Condition	<p>0001 The inlet cover is found to be open for 1 sec or more from the start of initial rotation of the connected device with the inlet cover, front cover, and delivery cover closed.</p> <p>0002 The exit cover is found to be open for 1 sec or more from the start of printing or from the start of initial rotation of the connected device with the inlet cover, front cover, and delivery cover closed.</p>

- Copier (from E601 to E830)

E601	
Main cause	The wiring is faulty (short circuit, open circuit). The hard disk drive is faulty. The DC controller PCB is faulty. The main controller PCB is faulty.
Condition	0000 The main controller PCB detects a fault in control information for image transfer between the main controller PCB and the hard disk drive. Or, the DC controller PCB detects a fault in control information for image transfer between main controller PCB and DC controller PCB.
E602	
Main cause	The wiring is faulty (short circuit, open circuit, connector disconnection). The installed system file is faulty. The hard disk drive is faulty. The main controller PCB is faulty.
Condition	0001 A fault in the mounting of the hard disk is detected when the boot ROM starts up the system on the hard disk. 0002 No appropriate system is found on the hard disk when the boot ROM tries to start up the system on the hard disk. 0003 A sector error occurs on the hard disk when the boot ROM starts up the system on the hard disk.
E604	
Main cause	The image memory is faulty. The main controller PCB is faulty.
Condition	0000 A fault exists in the image memory.
E605	
Main cause	The battery for image memory is faulty. The main controller PCB is faulty.
Condition	0000 A fault is detected in the voltage of the battery for the image memory.
E674	
Main cause	The fax board is faulty.
Condition	0000 An error exists on the FAX board.

E676	Any of the various printer boards (accessories) is faulty.
Main cause Condition	0000 A fault exists in any of the printer boards (accessories).
E677	Any of the various printer boards (accessories) is faulty. The main controller PCB is faulty.
Condition	0000 A communication fault exists between the main controller PCB and any of the various printer boards (accessories).
Caution	<p>In the case of E677,</p> <ul style="list-style-type: none"> • If it occurs when the main power supply is turned on, Suspect a hardware fault. Keep in mind that switching off and then on the power switch too fast can cause E677 to be indicated because of a specific timing interval needed to initialize the copier and the printer board. Be sure to wait for 5 sec or more before turning the main power switch back on. • If it occurs during normal use, If it occurs during printing and can be corrected after canceling the print job and turning off and then on the power switch, suspect an overload on the CPU. If an overload was imposed on the CPU of the printer board for some time (as when processing a large volume print data while receiving a large volume data from the network), E677 can be indicated at times. If so, cancel all print jobs, and turn off and then on the main power switch of the copier; advise the user to send print data on a job-by-job basis.
Main cause	Machine types are not compatible between Boot ROM and System. (e.g., Boot ROM for the iR8500 Copy model is mounted on the system for the iR8500 PS/PCL model.)
Condition	5802

<p>E710</p> <p>Main cause</p> <p>Condition</p>	<p>The DC controller PCB is faulty. The reader controller PCB is faulty. The main controller PCB is faulty.</p> <p>0001 The IPC (IC5) on the reader controller PCB cannot be initialized when the main power supply is turned on.</p> <p>0002 The IPC (IC40) on the DC controller PCB cannot be initialized when the main power supply is turned on.</p> <p>0003 The IPC (IC1003) on the machine controller PCB cannot be initialized when the main power is turned on.</p>
<p>E711</p> <p>Main cause</p> <p>Condition</p>	<p>The connector is not connected properly. The NE controller PCB is faulty. The copy data controller PCB is faulty. The ADF controller PCB is faulty. The finisher controller PCB is faulty.</p> <p>0001 Data has been written to the error register of the IPC (IC5) on the reader controller PCB 4 times or more within 1.5 sec.</p> <p>0002 Data has been written to the error register of the IPC (IC40) on the DC controller PCB 4 times or more within 2 sec.</p> <p>0003 Data has been written to the error register of the IPC (IC1003) on the main controller PCB 4 times or more within 2 sec.</p>
<p>E712</p> <p>Main cause</p> <p>Condition</p>	<p>The connector is not connected properly. The 24V power supply for the ADF is faulty. The ADF controller PCB is faulty. The reader controller PCB is faulty.</p> <p>0000 The communication IC (IPC) on the ADF controller PCB goes out of order.</p>
<p>E713</p> <p>Main cause</p> <p>Condition</p>	<p>The connector is not connected properly. The accessories power supply PCB for the finisher is faulty. The finisher controller PCB is faulty. The DC controller PCB is faulty.</p> <p>0000 The communications IC (IPC) on the finisher controller PCB goes out of order.</p>

E717	
Main cause	The wiring is faulty. (short circuit, open circuit). The copy data controller or the NE controller is faulty. The main controller PCB is faulty.
Condition	0001 The copy data controller or the NE controller is out of order or the wiring has an open circuit.
Caution	You must clear the error in service mode (COPIER>FUNCTION>CLEAR>ERR).
E719	
Main cause	The wiring is faulty (short circuit, open circuit). The coin vendor is faulty. The main controller PCB is faulty.
Condition	0002 The communication between coin vendor and controller PCB is disrupted.
Caution	You must clear the error in service mode (COPIER>FUNCTION>CLEAR>ERR).
E732	
Main cause	The cable connector is not connected properly. The reader controller PCB is faulty.
Condition	0001 The main controller PCB detects a fault in the communication between rear controller PCB and main controller PCB.
E733	
Main cause	The connector is not connected properly. The DC controller PCB is faulty.
Condition	0000 The machine controller PCB detects a fault in the communication between DC controller PCB and main controller PCB.
E737	
Main cause	The SDRAM is faulty. The main controller PCB is faulty.
Condition	0000 A fault exists in the SDRAM.

<p>E740</p> <p>Main cause Condition</p>	<p>The Ethernet card is faulty. The main controller PCB is faulty.</p> <p>0000 An Ethernet card fault is detected.</p>
<p>E741</p> <p>Main cause Condition</p>	<p>The PCI bus is not connected properly. The main controller PCB is faulty.</p> <p>0000 A fault exists in the PCI bus.</p>
<p>E744</p> <p>Main cause Condition Condition Caution Main cause Condition Main cause Condition</p>	<p>A mismatch of versions exists between the language module (Language) and the system installed to the hard disk; or, no language that can be used exist.</p> <p>0001 The version of the system installed to the hard disk and the version of the language module selected in user mode do not match.</p> <p>0002 The size of the downloaded language module exceeds a specific size.</p> <p>0003 The display language module selected in user mode does not exist; or, it is not an appropriate language module.</p> <p>0004 Downloading of the language module fails.</p> <p>In response to the error, the machine will automatically cancel the language selection of user mode; as such, when the machine is turned off and then on next time, it will use the language module (Japanese or English) that is built into the system.</p> <p>Machine models are not identical between Boot ROM and System. (e.g., Boot ROM for the iR5000 Copy model is mounted on the System for the iR8500 Copy model)</p> <p>1000</p> <p>HDD stored the system for another machine model is connected. (e.g., HDD for the iR8500 Copy model is changed the HDD for the iR105 Copy model)</p> <p>2000</p>

E745	
Main cause	Token Ring Board related error (e.g. faulty board, poor connection, wrong setting)
Condition	<p>0001 Token Ring PCI initialization error</p> <p>0002 MAC address is out of the specified range (The upper 3 bytes of the MAC address are other than 000085)</p> <p>0003 Token Ring board access error</p>
E800	
Main cause	The auto power-off circuit has an open circuit. The DC controller PCB is faulty.
Condition	<p>0000 An open circuit is detected in the auto power-off circuit for 3 sec or more.</p>
E804	
Main cause	The system fan (FM16) is faulty. The power supply cooling fan 1 (FM11) is faulty. The power cooling fan 2 (FM12) is faulty. The DC controller PCB is faulty. The main controller PCB is faulty.
Condition	<p>0000 The lock signal is detected for 5 sec or more although the power supply cooling fan (1 and 2) is being driven.</p> <p>0004 The reading of the ambient temperature of the main controller is 80°C or higher.</p>
Caution	In the case of a fault in the system fan, the data will be indicated in the form of an alarm (0008040004; alarm-2).
E805	
Main cause	The wiring is faulty (short circuit, open circuit). The fixing assembly heat discharge fan (FM2) is faulty. The DC controller PCB is faulty. The separation heat discharge fan is faulty.
Condition	<p>0001 The lock signal is detected for 5 sec or more although the fixing assembly heat discharging fan is being driven.</p> <p>0002 The lock signal is detected for 5 sec or more although the separation heat discharging fan is being driven.</p>

E820	
Main cause	The wiring is faulty (short circuit, open circuit). The drum fan (FM8) is faulty. The DC controller PCB is faulty.
Condition	0000 The lock signal is detected for 5 sec or more although the drum fan is being driven.
E823	
Main cause	The wiring is faulty (short circuit, open circuit). The pre-transfer charging assembly fan (FM10) is faulty. The deck controller PCB is faulty.
Condition	0000 The lock signal is detected for 5 sec or more although the pre-transfer charging assembly fan is being driven.
E830	
Main cause	The wiring is faulty (short circuit, open circuit). The separation fan (FM13) is faulty. The DC controller PCB is faulty.
Condition	0000 The lock signal is detected for 5 sec or more although the separation cooling fan is being driven.

**Prepared by
Office Imaging Products Quality Assurance Center
CANON INC.
Printed in U.S.A.**

REVISION 0 (JULY 2001) (21767, 32205, 23715)

5-1, Hakusan 7-chome, Toride-shi, Ibaraki 302-8501 Japan



This publication is
printed on 100%
recycled paper.

Canon

IR105

PARTS CATALOG

REVISION 0

200V 50/60Hz	F14-1611	MHP00001 -
230V 50Hz	F14-1621	QSH00001 -
208V 60Hz	F14-1631	MPT00001 -
230V 50Hz	F14-1641	QSJ00001 -
230V 50Hz	F14-1651	QEL00001 -
230V 50Hz	F14-1661	REL00001 -
230V 50Hz	F14-1671	SDL00001 -
230V 50Hz	F14-1681	TEB00001 -
230V 50Hz	F14-1691	UHQ00001 -

Canon

AUG. 2001

FY8-31FJ-000

PREFACE

This Parts Catalog contains listings of parts used in the iR105. Diagrams are provided with the listings to aid the service technician in identifying clearly, the item to be ordered.

Whenever ordering parts, consult this Parts Catalog for all of the information pertaining to each item. Be sure to include, in the Parts Request, the full item description, the item part number and the quantity.

Canon Inc.

Office Imaging Products Quality Assurance Center
5-1, Hakusan 7-chome,
Toride-city, Ibaraki 302-8501, Japan

COPYRIGHT © 2001 CANON INC.

Printed in U.S.A.

Imprimé au U.S.A.

Use of this manual should be strictly supervised to avoid disclosure of confidential information.

CONTENTS

A.	ASSEMBLY LOCATION DIAGRAM	350.	INTERNAL DELIVERY UPPER ASSEMBLY
		351.	EXTERNAL DELIVERY UPPER ASSEMBLY
020.	SPECIAL TOOLS	360.	DUPLEXING FEEDER ASSEMBLY
100.	EXTERNAL COVERS, PANELS, ETC.	420.	MIRROR ASSEMBLY 1
101.	MACHINE FRONT PLATE	430.	MIRROR ASSEMBLY 2
102.	INTERNAL COMPONENTS 1	460.	SCANNER ASSEMBLY
103.	INTERNAL COMPONENTS 2		
104.	INTERNAL COMPONENTS 3	510.	PHOTO-SENSITIVE DRUM ASSEMBLY
105.	INTERNAL COMPONENTS 4	550.	PRIMARY CORONA ASSEMBLY
106.	MACHINE REAR PLATE 1	570.	PRE-TRANSFER CORONA ASSEMBLY
107.	MACHINE REAR PLATE 2	580.	TRANSFER/SEPARATE CORONA ASSEMBLY
108.	MACHINE BOTTOM PLATE		
110.	POWER CORD TERMINAL ASSEMBLY (200V)	600.	AP KIT ASSEMBLY
		640.	DEVELOPING ASSEMBLY
111.	POWER CORD TERMINAL ASSEMBLY (208/220/240V)	645.	BUFFER ASSEMBLY
120.	DOOR SWITCH MOUNT ASSEMBLY	720.	SEPARATION CLAW DRIVE ASSEMBLY
130.	CONTROL PANEL ASSEMBLY	770.	WASTE TONER ASSEMBLY
190.	SEPARATION FIXING FAN ASSEMBLY	775.	WASTE TONER PIPE ASSEMBLY
194.	PRIMARY POLYGON LASER FAN ASSEMBLY		
195.	DRUM INTAKE FAN ASSEMBLY	810.	FIXING ASSEMBLY
210.	LENS MOUNT ASSEMBLY	900.	CONTROLLER BOX ASSEMBLY
215.	SCANNER MOUNT ASSEMBLY	910.	DC POWER SUPPLY PCB ASSEMBLY
230.	VERTICAL PATH DRIVE ASSEMBLY	920.	CONTROL PANEL CPU PCB ASSEMBLY
231.	LIFTER DRIVE ASSEMBLY	925.	CONTROL PANEL INVERTER PCB ASSEMBLY
250.	MAIN DRIVE ASSEMBLY	926.	CONTROL PANEL PCB ASSEMBLY
251.	DRUM DRIVE ASSEMBLY	930.	DC CONTROLLER PCB ASSEMBLY
260.	PAPER PICK-UP DRIVE ASSEMBLY	935.	READER CONTROL PCB ASSEMBLY
261.	CASSETTE PICK-UP DRIVE ASSEMBLY	940.	POTENTIAL MEASURING PCB ASSEMBLY
263.	LEFT PICK-UP DRIVE ASSEMBLY	945.	INVERTER PCB ASSEMBLY
264.	MULTI FEED DRIVE ASSEMBLY	960.	AC DRIVER PCB ASSEMBLY
270.	DEVELOPING DRIVE ASSEMBLY	970.	DOCUMENT DETECT PCB ASSEMBLY
275.	TONER CARTRIDGE DRIVE ASSEMBLY	980.	H.V. AC TRANSFORMER PCB ASSEMBLY
280.	WASTE TONER DRIVE ASSEMBLY	985.	H.V. DC TRANSFORMER PCB ASSEMBLY
300.	CASSETTE	B.	LIST OF CONNECTORS
302.	1.5K RIGHT PAPER STOCK ASSEMBLY	C.	LIST OF STANDARD FASTENERS
303.	1.5K LEFT PAPER STOCK ASSEMBLY		
305.	CASSETTE HEATER ASSEMBLY	D.	NUMERICAL INDEX
311.	CASSETTE PICK-UP ASSEMBLY		
312.	FRONT DECK (RIGHT) PICK-UP ASSEMBLY		
313.	FRONT DECK (LEFT) PICK-UP ASSEMBLY		
315.	MULTI FEED ASSEMBLY		
316.	MULTI FEED TRAY ASSEMBLY		
320.	FIXING/FEEDER FRAME ASSEMBLY		
325.	REGISTRATION/TRANSFER ASSEMBLY		
330.	FEEDER ASSEMBLY		

HOW TO USE PART LISTS

Assembly Location Diagrams. These diagrams show the locations of major assemblies of the copier. Their names are identified in rectangular boxes. Below each box is the number of the Figure which shows an exploded view of the assembly.

Finding a Parts Number. Refer to the Assembly Location Diagrams and find the Figure Number of the assembly of interest. Turn to the page(s), locate the part on the exploded view, and find its Key Number. Refer to the Parts List on the page facing the exploded view and find the Key Number, Part Number and quantity required for your type of machine.

Note : While looking for a Part Number, pay particular attention to the voltage listed in the SERIAL NUMBER/REMARKS column to ensure that the Part Number selected is for your type of machine.

Immediate shipping or action regarding the part depends on using its correct Part Number.

Parts List pages. The Parts List pages contain the following columns and information.

(1) Figure and Key Number column. The first column shows the Figure Number of the illustration corresponding to the Parts List, and the Key Number that identifies the part on the illustration.

(2) Part Number. The second column shows the Part Number for the part. This Number must be used when ordering replacement parts. The parts and assemblies identified as "NPN" do not have parts numbers or are not in stock, i.e., they are not available

for ordering.

Note : The last three digits (suffix) of the Parts Number are called the Revision Number.

The Revision Number is changed if the part is modified. Information regarding such changes will be provided by Service Information Bulletins. These Bulletins should be read carefully.

(3) Rank N. Parts marked "N" are service parts, but are not stock items. They are produced on a special-order basis.

(4) Quantity column. The quantity shown in this column is the number of parts used in the Figure. However, the quantity listed for an assembly indicates the number of that assembly per machine.

The letters in this column indicate that the quantity of a part is not specified, allowing the use of the number of parts needed for assembly and that the quantity cannot be mentioned clearly.

R F...listed for reference only.

AR...quantity not specified or cannot be specified; used in quantities as necessary at time of assembly.

(5) Description column. The Description column lists the description that should be used when ordering the part.

(6) Serial Number/Remarks. When there are differences in the specifications of power supply voltage, frequency, etc., the differences are described in words or indicated by one, two or three letters in front of the serial number.

(Example)

Serial number ABC00001
↑ These are the
descriptive indicator.

(2) Figure and Key Number column. The second column lists the Figure and Key Number for each occurrence of the part in the illustrations.

If a modified model and a part are no longer interchangeable, the serial number of copiers for which the part can be used is shown in this column. If there is no indication the part can be used with all models.

Connectors list. Part numbers of connectors used in copiers and designated as Service Parts are listed in numerical order by connector number.

For connectors of which the housing and contacts are a single unit, there are no part numbers for the contact.

Connectors that are mounted on PCBs are indicated as "PCB" in the connector column. The part numbers for these connectors should be looked for in the PCB parts list.

List of Standard Fasteners. This specifications list incorporates screws, nuts, washers and shim washers, retaining rings, pins, and spacers that are used in all copiers (including optional equipment).

Numerical Index. There is a Numerical Index at the end of this catalog; it lists in numerical order every Part Number contained in the Parts Lists. The Numerical Index contains the following columns and information.

(1) Part Number. The first column shows the Part Number.

FIGURE A ASSEMBLY LOCATION DIAGRAM(1/5)
 主要部品配置図(1/5)

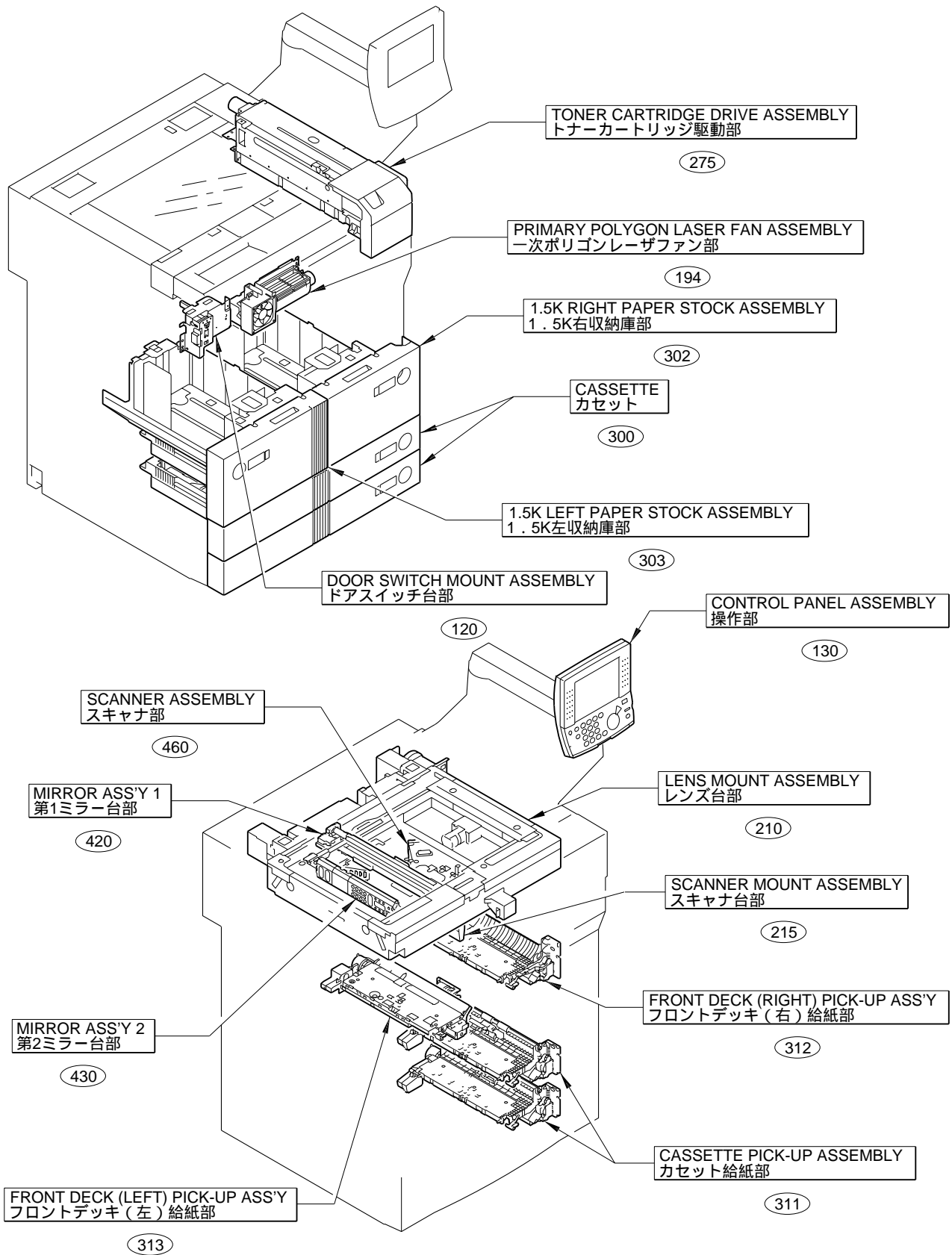

FIGURE A ASSEMBLY LOCATION DIAGRAM(2/5)
 主要部品配置図(2/5)

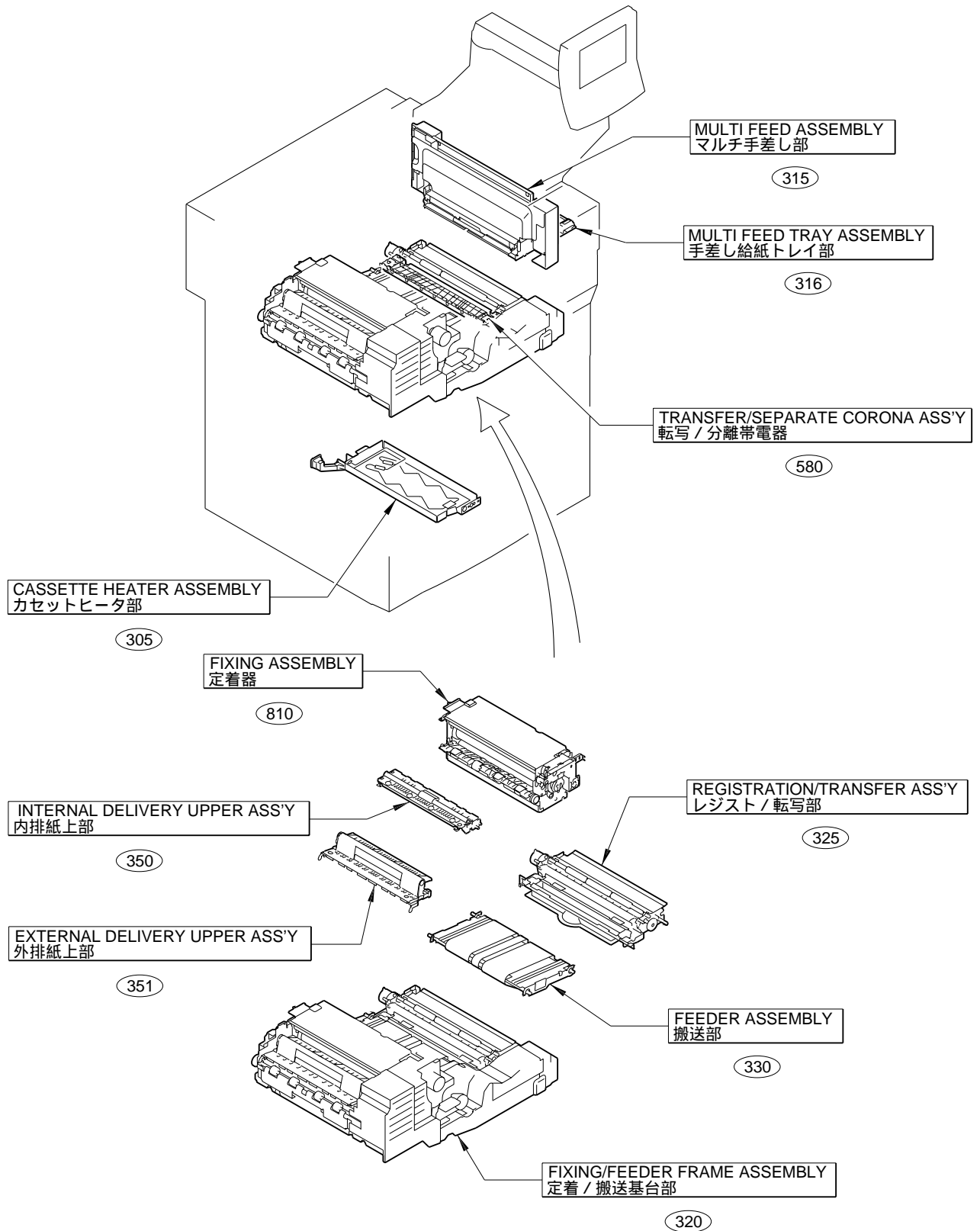

FIGURE A ASSEMBLY LOCATION DIAGRAM(3/5)
 主要部品配置図(3/5)

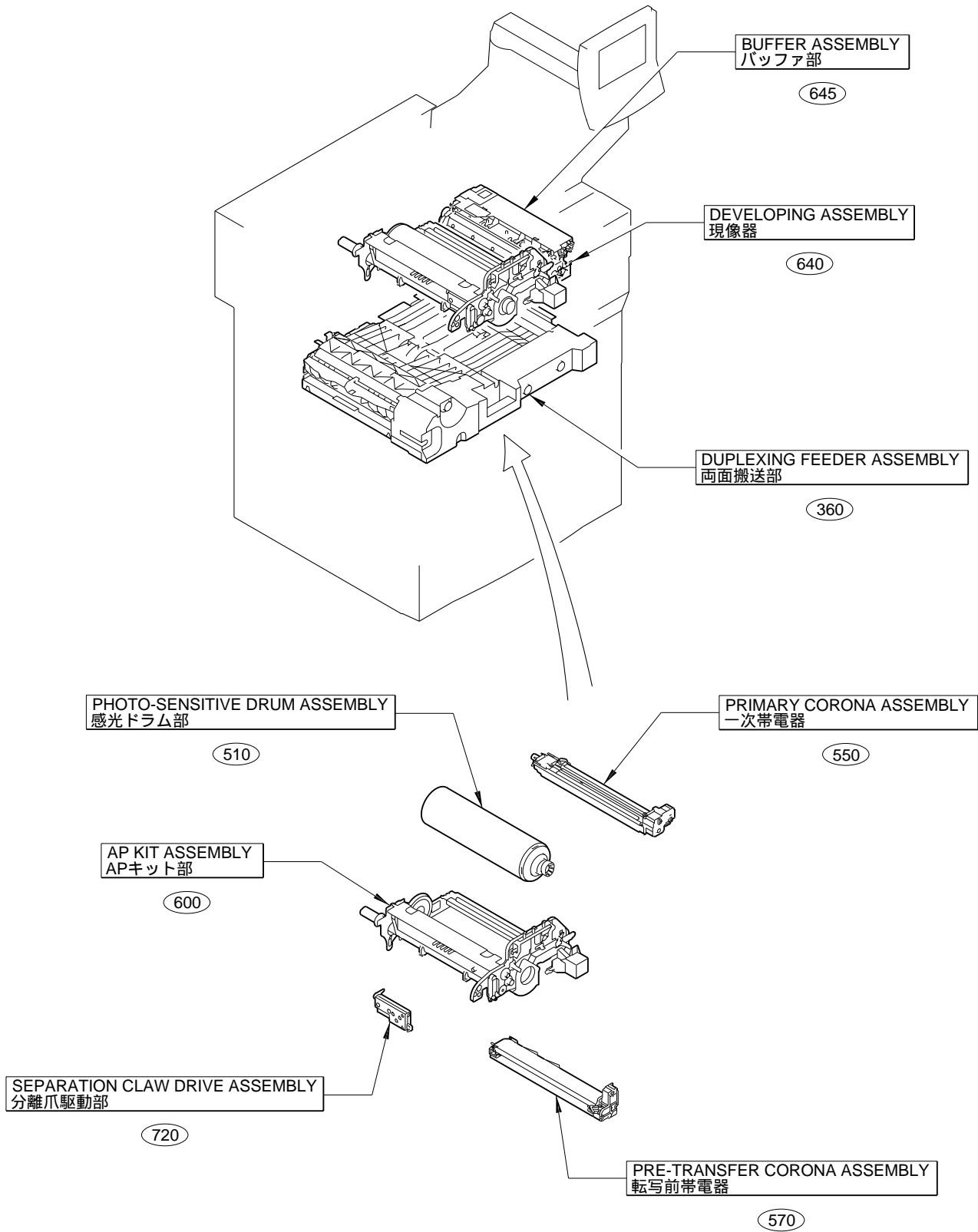

FIGURE A ASSEMBLY LOCATION DIAGRAM(4/5)
 主要部品配置図(4/5)

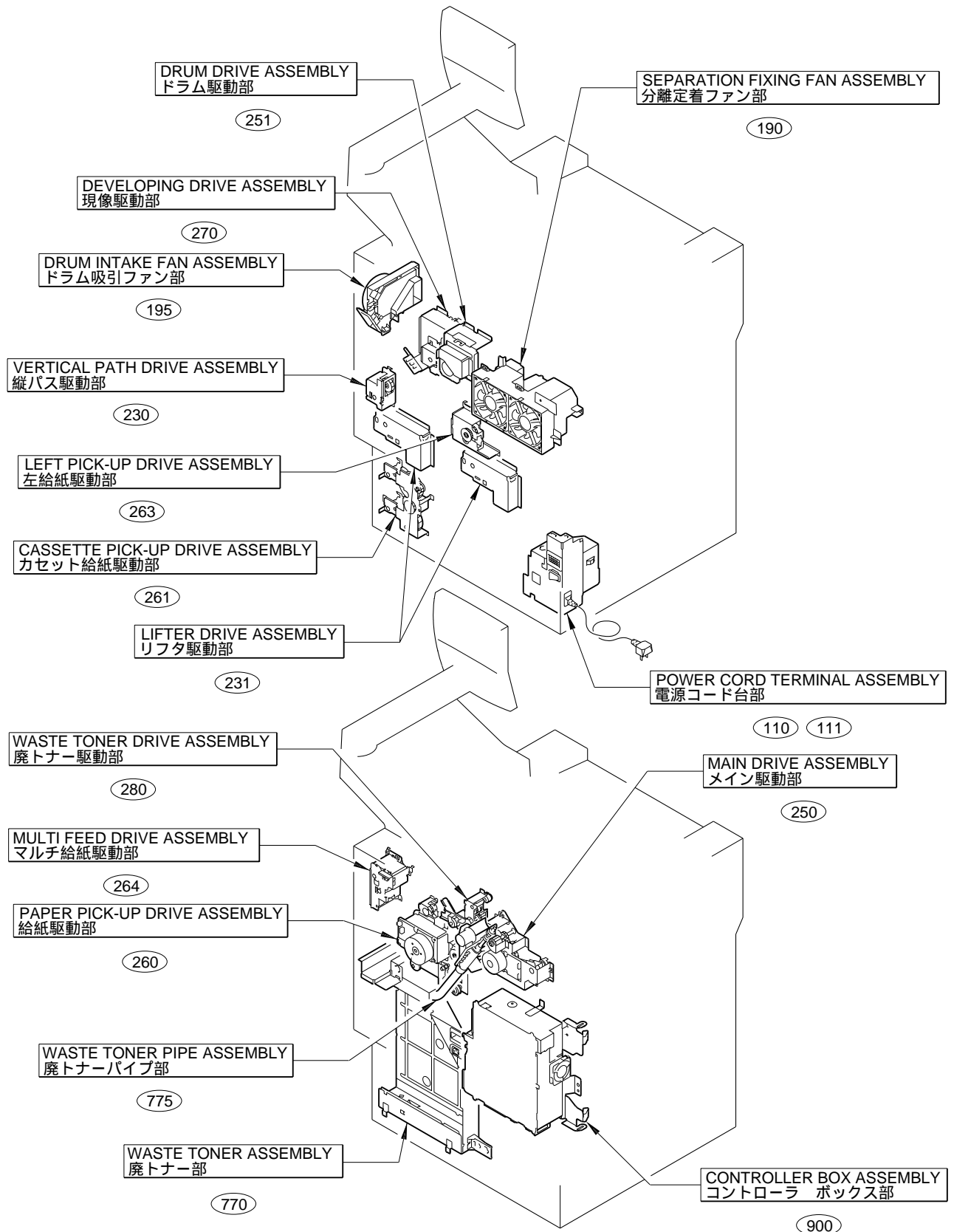

FIGURE A ASSEMBLY LOCATION DIAGRAM(5/5)
 主要部品配置図(5/5)

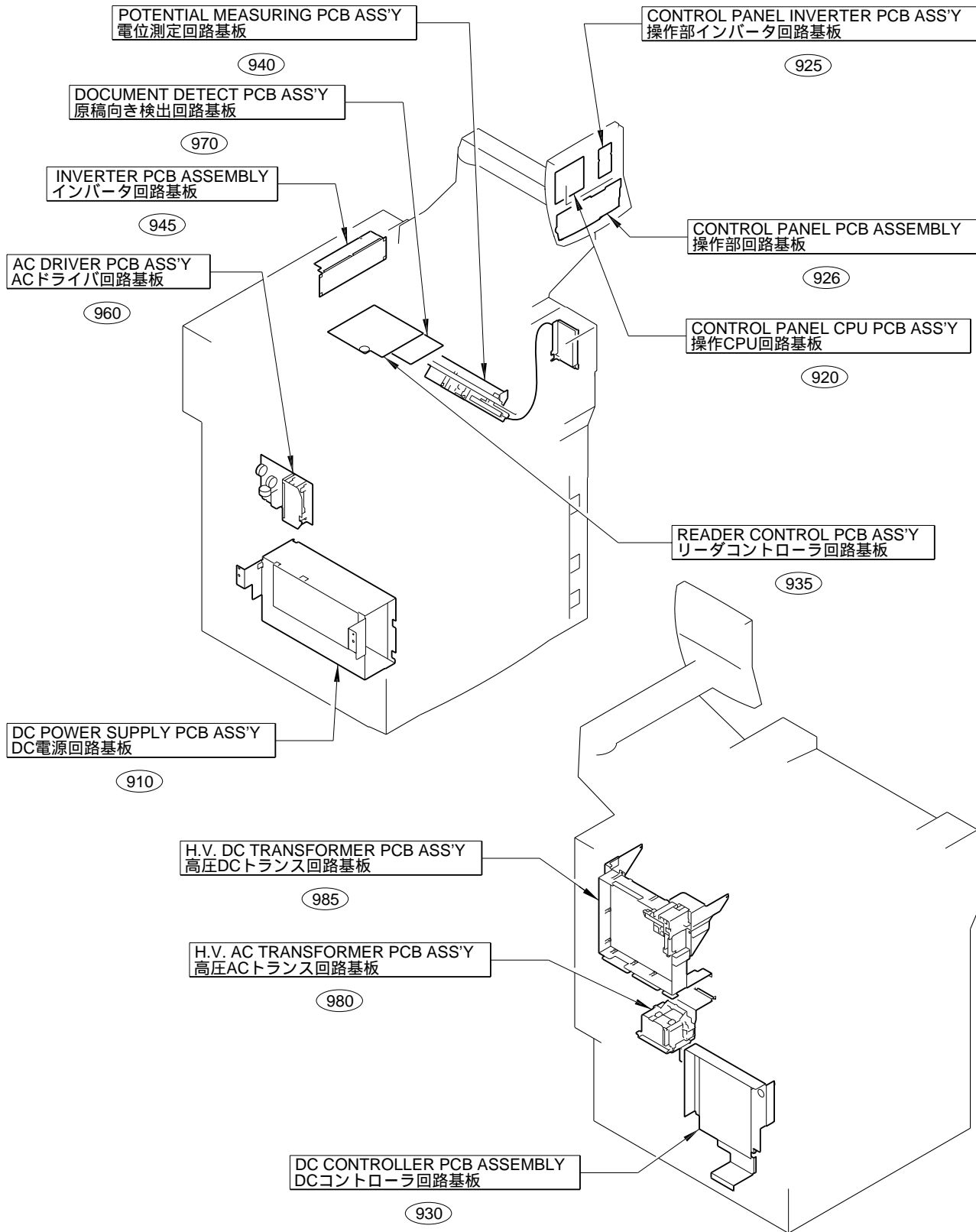

FIGURE 020 SPECIAL TOOLS 特殊工具

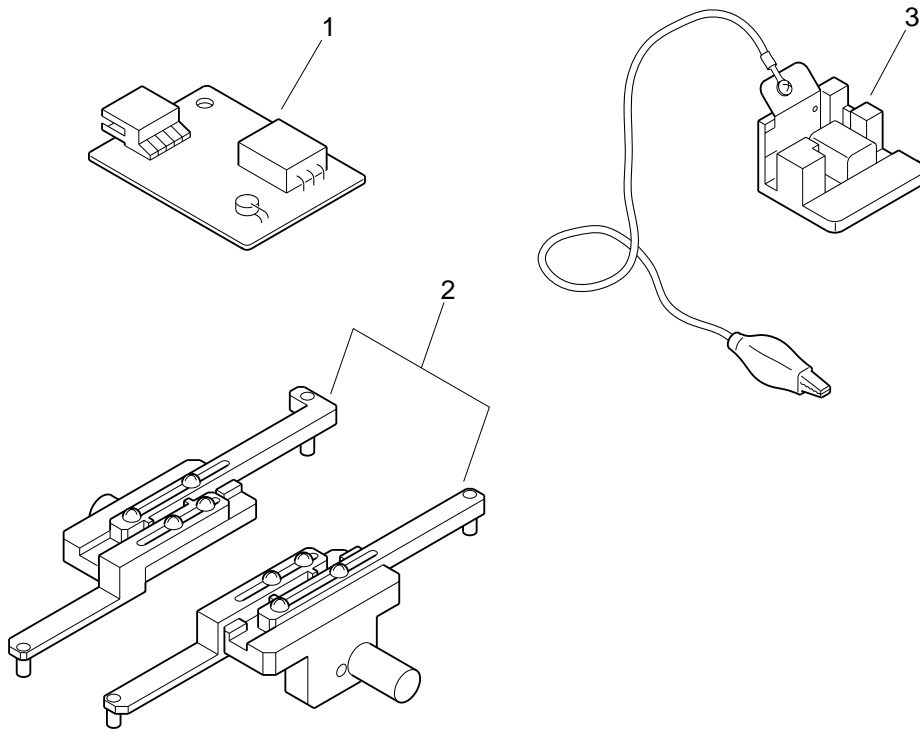

FIGURE & KEY NO.	PART NUMBER	RANK	QTY	DESCRIPTION	SERIAL NUMBER / REMARKS
020 -	NPN		RF	SPECIAL TOOLS 特殊工具	
1	FY9 - 3014 - 000		1	ENVIRONMENT SENSOR TOOL 環境センサ チェック工具	
2	FY9 - 3040 - 020		1	MIRROR POSITIONING TOOLS ミラー位置決め工具	
3	FY9 - 3041 - 000		1	TERMINAL, POTENTIAL SENSOR 電位センサ チェック電極	

FIGURE 100 EXTERNAL COVERS, PANELS, ETC.
外装カバー

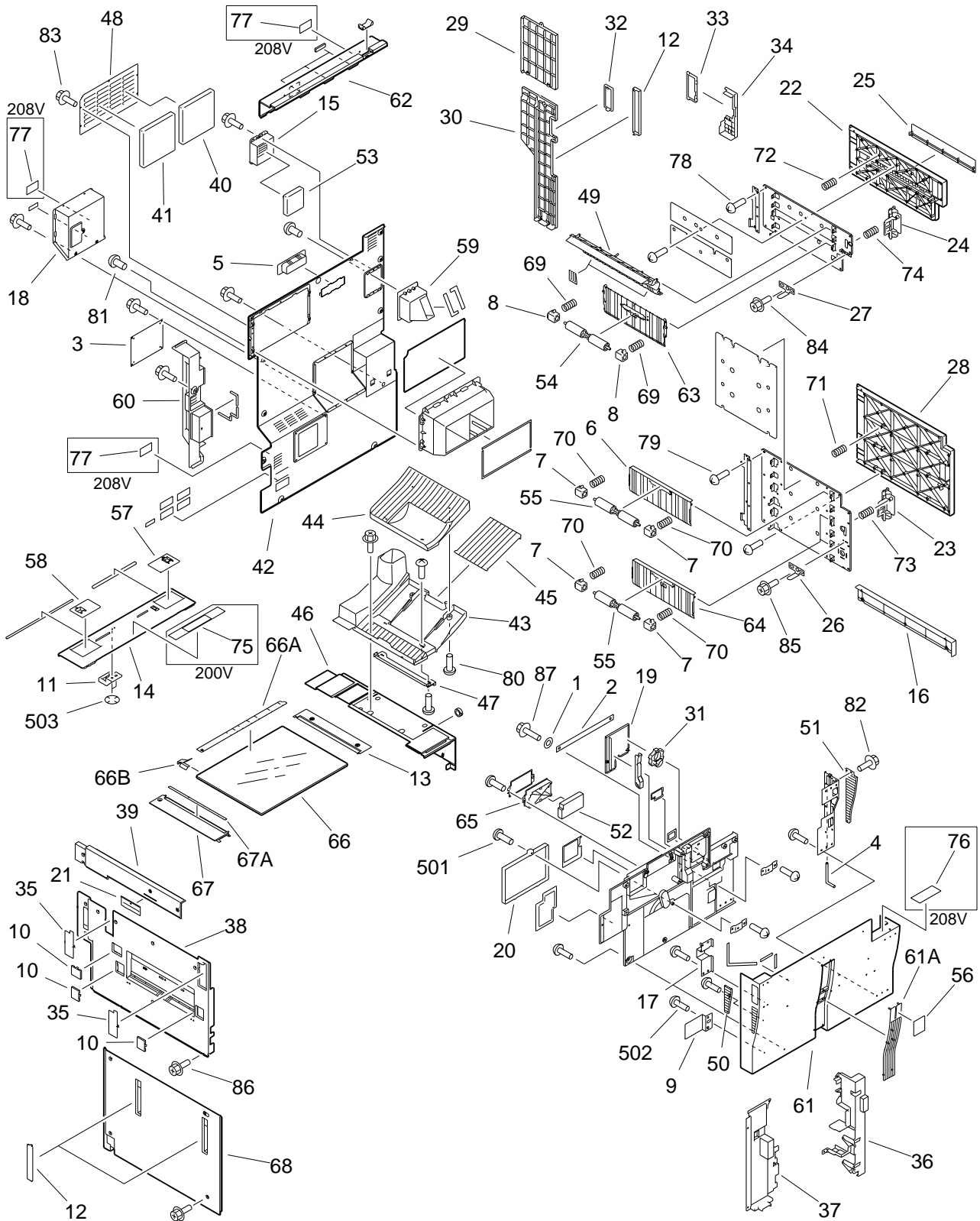

FIGURE & KEY NO.	PART NUMBER	RANK	QTY	DESCRIPTION	SERIAL NUMBER / REMARKS
100 -	NPN		RF	EXTERNAL COVERS, PANELS, ETC. 外装カバー	
1	FA2 - 7162 - 000		1	WASHER, PLAIN バンド ワッシャ	
2	FA6 - 0745 - 000		1	TAPE, DOOR ドア テープ	
3	FB1 - 7157 - 000		1	COVER カバー	
4	FB2 - 0037 - 000		1	PIN, HINGE ヒンジ ピン	
5	FB2 - 1492 - 000		1	HANDLE 把手	
6	FB2 - 7750 - 000		1	GUIDE, VERTICAL PATH SWING 縦パス揺動ガイド	
7	FB2 - 7755 - 000		6	BUSHING ブッシング	
8	FB2 - 7755 - 000		2	BUSHING ブッシング	
9	FB2 - 7864 - 000		1	PLATE, MAGNET マグネット受け板	
10	FB2 - 8021 - 000		3	COVER, CAP, LEFT キャップ カバー(左)	
11	FB2 - 8043 - 000		1	SUPPORT, REAR COVER, UPPER 後カバー支台(上)	
12	FB2 - 8102 - 000		3	COVER, HANDLE, 1 把手カバー(1)	
13	FB2 - 8226 - 000		1	SUPPORT, GLASS, RIGHT 右ガラス押え	
14	FB4 - 1359 - 000		1	COVER, REAR UPPER 後上カバー	
15	FB4 - 1391 - 000		1	CASE, OZONE FILTER, DRUM オゾン フィルタ ケース(ドラム)	
16	FB4 - 1423 - 000		1	COVER, RIGHT LOWER 右下カバー	
17	FB4 - 1437 - 000		1	ACTUATOR アクチュエータ	
18	FB4 - 1558 - 000		1	COVER, CONNECTOR コネクタ カバー	
19	FB4 - 1717 - 000		1	COVER, TOOL 工具カバー	
20	FB4 - 1727 - 000		1	COVER, SERVICE BOOK サービス ブック カバー	
21	FB4 - 1735 - 000		1	PLATE, MIRROR MOUNT STOP ミラー台ストップ	
22	FB4 - 1960 - 000		1	RIGHT DOOR, UPPER 右扉(上)	
23	FB4 - 1965 - 000		1	HANDLE, RIGHT DOOR 右扉把手	
24	FB4 - 1965 - 000		1	HANDLE, RIGHT DOOR 右扉把手	
25	FB4 - 1967 - 000		1	PLATE, BLANKING 目隠し板	
26	FB4 - 1969 - 000		1	FLAG, RIGHT DOOR SENSOR 右扉センサ フラグ	
27	FB4 - 1969 - 000		1	FLAG, RIGHT DOOR SENSOR 右扉センサ フラグ	
28	FB4 - 1970 - 000		1	RIGHT DOOR, LOWER 右扉(下)	
29	FB4 - 5297 - 000		1	COVER, RIGHT REAR 右後カバー	

FIGURE & KEY NO.	PART NUMBER	RANK	QTY	DESCRIPTION	SERIAL NUMBER / REMARKS
100 - 30	FB4 - 5298 - 000		1	COVER, WASTE TONER 廃トナー カバー	
31	FB4 - 5311 - 000		1	KNOB, DRUM ドラム ツマミ	
32	FB4 - 7478 - 000		1	COVER, LATCH, RIGHT ラッチ板カバー (右)	
33	FB4 - 7882 - 000		1	COVER, LATCH BLANKING ラッチ目隠しカバー	
34	FB4 - 7883 - 000		1	COVER, HANDLE 把手カバー	
35	FB5 - 6916 - 000		2	COVER, BLANKING 目隠し板	
36	FB5 - 6988 - 000		1	COVER, RIGHT LOWER, INSIDE 右下内カバー	
37	FB5 - 6989 - 000		1	COVER, LEFT LOWER, INSIDE 左下内カバー	
38	FB5 - 6992 - 000		1	COVER, LEFT UPPER 左上カバー	
39	FB5 - 7001 - 000		1	COVER, LEFT UPPER, SMALL 左上カバー (小)	
40	FB6 - 0397 - 000		1	FILTER, OZONE, SEPARATION オゾン フィルタ (分離)	
41	FB6 - 0403 - 000		1	FILTER, OZONE, FIXING オゾン フィルタ (定着)	
42	FB6 - 0404 - 000		1	PANEL, REAR 後カバー	
43	FB6 - 0442 - 000		1	TRAY, ADF DELIVERY ADF排紙トレイ	
44	FB6 - 0443 - 000		1	TRAY, DELIVERY, 1 排紙トレイ (1)	
45	FB6 - 0444 - 000		1	TRAY, DELIVERY, 3 排紙トレイ (3)	
46	FB6 - 0446 - 000		1	COVER, RIGHT UPPER 右上カバー	
47	FB6 - 0448 - 000		1	TRAY, DELIVERY, 2 排紙トレイ (2)	
48	FB6 - 0500 - 000		1	COVER, FILTER フィルタ カバー	
49	FB6 - 0528 - 000		1	GUIDE, REGISTRATION, SWING レジスト前揺動ガイド	
50	FB6 - 0589 - 000		1	GUIDE, AIR, 1 エア ガイド (1)	
51	FB6 - 0590 - 000		1	GUIDE, AIR, 2 エア ガイド (2)	
52	FB6 - 0603 - 000		1	FILTER, AIR, PRIMARY エア フィルタ (1次)	
53	FB6 - 0776 - 000		1	FILTER, OZONE, DRUM オゾン フィルタ (ドラム)	
54	FB6 - 2397 - 000		1	ROLLER コロ	
55	FB6 - 2397 - 000		3	ROLLER コロ	
56	FB6 - 2415 - 000		1	EMBLEM エンブレム	200/220/240V
	FB6 - 2416 - 000		1	EMBLEM エンブレム	208V
57	FF5 - 5593 - 030		1	PLATE, POCKET, RIGHT ポケット板 (右)	
58	FF5 - 5594 - 030		1	PLATE, POCKET, LEFT 2 ポケット板金 (左2)	

FIGURE & KEY NO.	PART NUMBER	RANK	QTY	DESCRIPTION	SERIAL NUMBER / REMARKS
100 - 59	FF5 - 7942 - 000		1	DUCT, DRUM, 3 ドラム ダクト(3)	
60	FF6 - 1067 - 000		1	PANEL, SYSTEM CONNECTOR システム コネクタ カバー	
61	FF6 - 1524 - 000		1	PANEL, FRONT 前カバー	
61 A	FB5 - 6996 - 000		1	PLATE, FRONT COVER 前カバー プレート	
62	FF6 - 1526 - 000		1	COVER, REAR UPPER 後上カバー	
63	FF6 - 1531 - 000		1	GUIDE, VERTICAL PATH SWING, U 縦パス揺動ガイド(上)	
64	FF6 - 1532 - 000		2	GUIDE, VERTICAL PATH SWING, L 縦パス揺動ガイド(下)	
65	FF6 - 1541 - 000		1	CASE, AIR FILTER, 1 エア フィルタ ケース(1)	
66	FF6 - 1849 - 000		1	GLASS, COPYBOARD 原稿台ガラス	AB SIZE
	FF6 - 1998 - 000		1	GLASS, COPYBOARD 原稿台ガラス	A/INCH SIZE
	FF6 - 1997 - 000		1	GLASS, COPYBOARD 原稿台ガラス	A SIZE
	FF6 - 1999 - 000		1	GLASS, COPYBOARD 原稿台ガラス	AB/INCH SIZE
66 A	FS7 - 8291 - 000		1	PLATE, LENGTH INDEX 横サイズ プレート	AB SIZE
	FS7 - 8319 - 000		1	PLATE, LENGTH INDEX 横サイズ プレート	A/INCH SIZE
	FS7 - 8318 - 000		1	PLATE, LENGTH INDEX 横サイズ プレート	A SIZE
66 B	FS7 - 8320 - 000		1	PLATE, LENGTH INDEX 横サイズ プレート	AB/INCH SIZE
	FB3 - 9907 - 000		1	PLATE, GROUNDING アース板	
67	FF6 - 1850 - 000		1	SUPPORT, GLASS, LEFT ガラス押え(左)	AB SIZE
	FF6 - 2002 - 000		1	SUPPORT, GLASS, LEFT ガラス押え(左)	A/INCH SIZE
	FF6 - 2001 - 000		1	SUPPORT, GLASS, LEFT ガラス押え(左)	A SIZE
67 A	FF6 - 2003 - 000		1	SUPPORT, GLASS, LEFT ガラス押え(左)	AB/INCH SIZE
	FS7 - 8290 - 000		1	PLATE, SIZE INDEX 縦サイズ プレート	AB SIZE
	FS7 - 8323 - 000		1	PLATE, SIZE INDEX 縦サイズ プレート	A/INCH SIZE
	FS7 - 8322 - 000		1	PLATE, SIZE INDEX 縦サイズ プレート	A SIZE
	FS7 - 8324 - 000		1	PLATE, SIZE INDEX 縦サイズ プレート	AB/INCH SIZE
68	FF9 - 1901 - 000		1	LEFT PANEL, LOWER 左カバー(下)	
69	FS5 - 2921 - 000		2	SPRING, COMPRESSION アッシュク バネ	
70	FS5 - 2921 - 000		6	SPRING, COMPRESSION アッシュク バネ	
71	FS5 - 2922 - 000		4	SPRING, COMPRESSION アッシュク バネ	
72	FS5 - 2922 - 000		6	SPRING, COMPRESSION アッシュク バネ	

FIGURE & KEY NO.	PART NUMBER	RANK	QTY	DESCRIPTION	SERIAL NUMBER / REMARKS
100 - 73	FS6 - 2826 - 000		1	SPRING, COMPRESSION アッシュク バネ	
74	FS6 - 2826 - 000		1	SPRING, COMPRESSION アッシュク バネ	
75	FS6 - 8823 - 000		1	LABEL, CLEANING INDICATE 清掃指示ラベル	200V
76	FS6 - 8992 - 000		1	LABEL, TONER トナー ラベル	208V
77	FS8 - 8194 - 000		3	LABEL, "WARNING CONNECTOR" コネクタ注意ラベル	208V
78	XA9 - 0605 - 000		7	SCREW, M4X8 タイト ネジ	
79	XA9 - 0605 - 000		15	SCREW, M4X8 タイト ネジ	
80	XA9 - 0606 - 000		6	SCREW, P, M4X10 P タイト ネジ	
81	XA9 - 0615 - 000		8	SCREW, M4X8 タイト ネジ	
82	XA9 - 0628 - 000		2	SCREW, RS, M4X8 RS タイト ネジ	
83	XA9 - 0629 - 000		11	SCREW, RS, M4X8 RS タイト ネジ	
84	XA9 - 0629 - 000		1	SCREW, RS, M4X8 RS タイト ネジ	
85	XA9 - 0629 - 000		1	SCREW, RS, M4X8 RS タイト ネジ	
86	XA9 - 0643 - 000		AR	SCREW, RS, M4X10 RS タイト ネジ	
87	XA9 - 0721 - 000		2	SCREW, RS, M4X10 RS タイト ネジ	
501	XB1 - 2400 - 606		3	SCREW, MACH., TRUSS HEAD, M4X6 バインド ネジ	
502	XB4 - 5401 - 006		21	SCREW, P, M4X10 P タイト ネジ	
503	XD2 - 2300 - 402		2	RING, TOOTHED LOCK ハツキ トメワ	

FIGURE 101 MACHINE FRONT PLATE

本体前側板

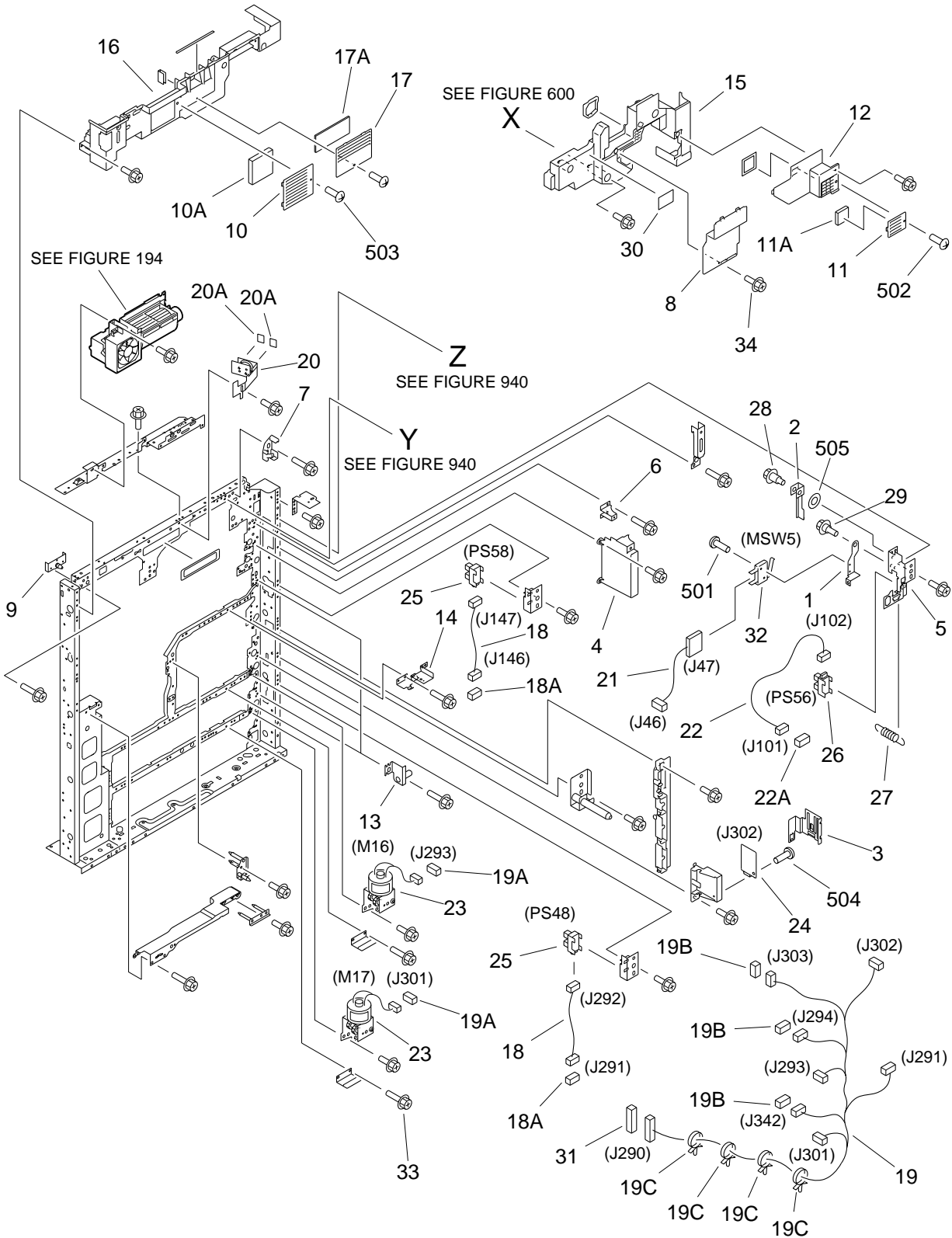

FIGURE & KEY NO.	PART NUMBER	RANK	QTY	DESCRIPTION	SERIAL NUMBER / REMARKS
101 -	NPN		RF	MACHINE FRONT PLATE 本体前側板	
1	FB2 - 7559 - 000		1	MOUNT, SWITCH スイッチ台	
2	FB2 - 7560 - 000		1	COVER, SWITCH スイッチ カバ-	
3	FB2 - 8345 - 000		1	PLATE, GROUNDING ア-ス板	
4	FB4 - 1386 - 000		1	COVER, INTERNAL, RIGHT LOWER 内カバー (右下)	
5	FB4 - 1430 - 000		1	HOLDER, DOOR SENSOR ドア センサ ホルダ	
6	FB4 - 5257 - 000		1	PLATE, TAPE テープ板	
7	FB5 - 0532 - 000		1	GUIDE, POTENTIAL CONTROL CABLE 電位制御束線ガイド	
8	FB6 - 0405 - 000		1	COVER, INTERNAL, PRIMARY 内カバー (一次)	
9	FF5 - 7658 - 000		1	PLATE, POSITIONING, FIXING 定着位置決め板	
10	FF5 - 7662 - 000		1	COVER, FILTER フィルタ カバー	
10 A	FB4 - 1409 - 000		1	FILTER, AIR エア フィルタ	
11	FF5 - 7664 - 000		1	COVER, FILTER フィルタ カバー	
11 A	FB4 - 1407 - 000		1	FILTER, AIR エア フィルタ	
12	FF5 - 7882 - 020		1	COVER, INTERNAL, PRE-TRANSFER 内カバー (転写前)	
13	FF5 - 8139 - 000		3	PLATE, POSITIONING, FRONT 給紙位置決め板 (前)	
14	FF5 - 8152 - 000		1	PLATE, LOCK, RIGHT 右ロック板	
15	FF6 - 1336 - 000		1	COVER, INTERNAL, AP KIT 内カバー (APキット)	
16	FF6 - 1501 - 000		1	COVER, INTERNAL, UPPER 内カバー (上)	
17	FF6 - 1529 - 000		1	COVER, FILTER フィルタ カバー	
17 A	FB6 - 0582 - 000		1	FILTER, PRIMARY FAN 1次ファン フィルタ	
18	FG6 - 1892 - 000		2	CABLE, RIGHT DOOR OPEN/CLOSE 右扉開閉束線	J146,147 J291,292
18 A	VS1 - 5057 - 004		2	CONNECTOR, SNAP TIGHT チュウケイ コネクタ	J146,291
19	FG6 - 1901 - 000		1	CABLE, MACHINE FRONT LOWER 本体前下束線	J290,291,293,294 J301,302,303,342
19 A	VS1 - 5057 - 002		2	CONNECTOR, SNAP TIGHT チュウケイ コネクタ	J293,301
19 B	VS1 - 5057 - 003		3	CONNECTOR, SNAP TIGHT チュウケイ コネクタ	J294,303,342
19 C	WT2 - 5565 - 000		4	CLAMP, CABLE ソクセン オサエ	
20	FG6 - 2023 - 000		1	BEAM DETECT SENSOR PCB ASS'Y ビーム ディテクタ センサ回路基板	
20 A	FB4 - 3118 - 000		2	SHEET, LIGHT BLOCKING 遮光シート	
21	FG6 - 2328 - 000		1	CABLE, MULTI DOOR INTERLOCK マルチ扉インターロック束線	J46,47

FIGURE & KEY NO.	PART NUMBER	RANK	QTY	DESCRIPTION	SERIAL NUMBER / REMARKS
101 - 22	FG6 - 2330 - 000		1	CABLE, MULTI DOOR, CONNECTING マルチ扉中継束線	J101,102
22A	VS1 - 5057 - 003		1	CONNECTOR, SNAP TIGHT チュウケイ コネクタ	J101
23	FH6 - 1960 - 000		2	MOTOR, DC DCモータ	M16,17 J293,301
24	FH7 - 7342 - 000		1	SENSOR UNIT, HUMIDITY 湿度センサ	J302
25	FH7 - 7462 - 000		2	PHOTO-INTERRUPTER フォトインタラプタ	PS48,58 J292,147
26	FH7 - 7462 - 000		1	PHOTO-INTERRUPTER フォトインタラプタ	PS56 J102
27	FS5 - 2958 - 000		1	SPRING, TENSION ヒツパリ バネ	
28	FS5 - 9166 - 000		1	SCREW, STEPPED, M4 ダン ビス	
29	FS5 - 9216 - 000		1	SCREW, RS STEPPED, M4 RS タイト 段ビス	
30	FS6 - 8821 - 000		1	LABEL, "WARNING LASER" レーザ注意ラベル	200/208V
	FS6 - 8822 - 000		1	LABEL, "WARNING LASER" レーザ注意ラベル	220/240V
31	VS1 - 6319 - 022		1	CONNECTOR, SNAP TIGHT チュウケイ コネクタ	J290
32	WC4 - 5153 - 000		1	MICRO SWITCH マイクロ スイッチ	MSW5 J47
33	XA9 - 0630 - 000		18	SCREW, RS, M4X10 RS タイト ネジ	
34	XA9 - 0643 - 000		AR	SCREW, RS, M4X10 RS タイト ネジ	
501	XB1 - 2230 - 809		2	SCREW, MACH., TRUSS HEAD, M2.3X8 バインド ネジ	
502	XB1 - 2400 - 606		1	SCREW, MACH., TRUSS HEAD, M4X6 バインド ネジ	
503	XB1 - 2400 - 806		2	SCREW, MACH., TRUSS HEAD, M4X8 バインド ネジ	
504	XB4 - 7300 - 609		1	SCREW, TAPPING, TRUSS HEAD, M3X6 バインド タッピン ネジ	
505	XD1 - 1104 - 135		1	SHIM ヒョウジュン ワッシャ	

FIGURE 102 INTERNAL COMPONENTS 1

本体機械内部 (1)

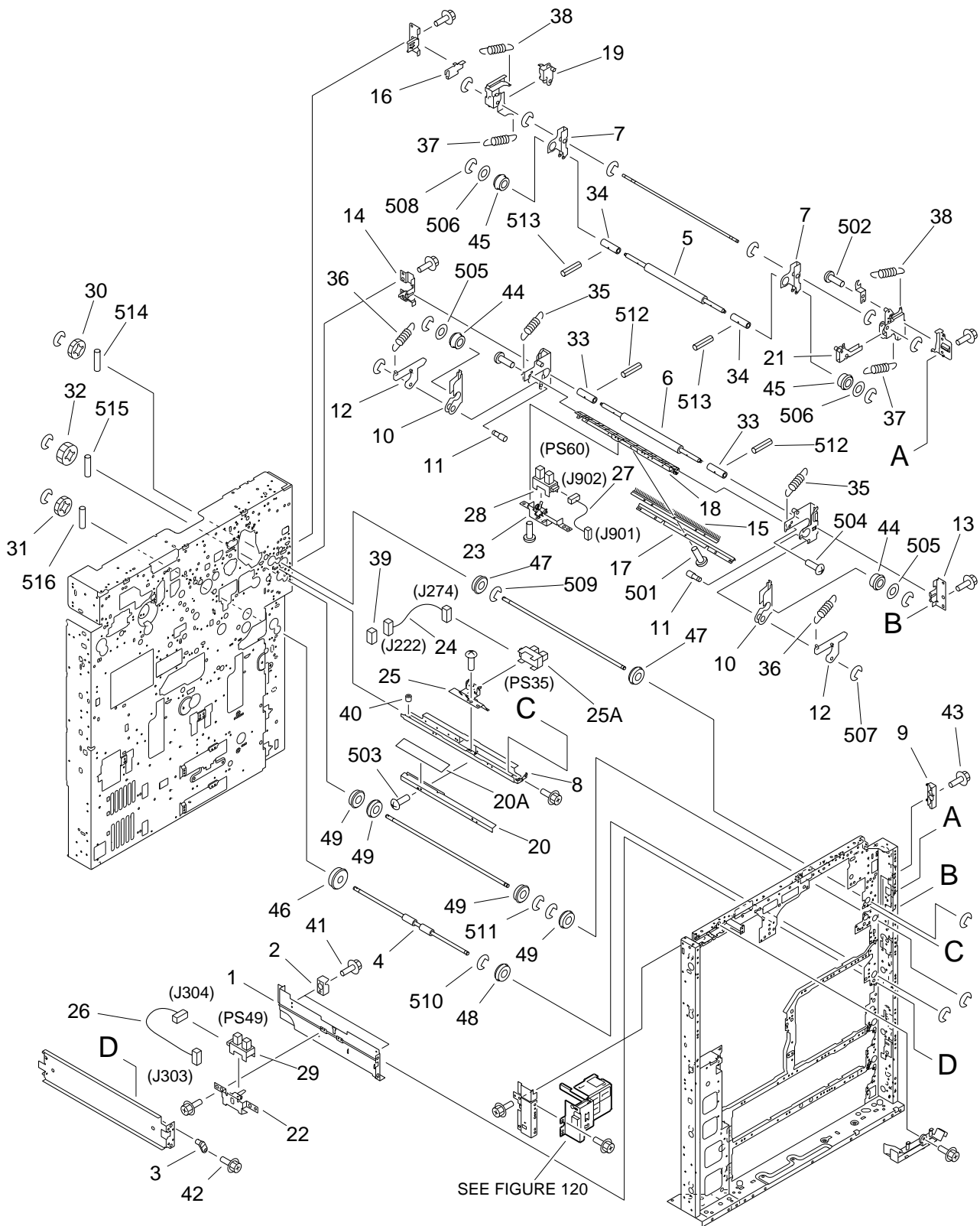

FIGURE & KEY NO.	PART NUMBER	RANK	QTY	DESCRIPTION	SERIAL NUMBER / REMARKS
102 -	NPN		RF	INTERNAL COMPONENTS 1 本体機械内部 (1)	
1	FB2 - 8002 - 030		1	GUIDE, VERTICAL PATH, MIDDLE 中縦パス ガイド	
2	FB2 - 8003 - 000		2	GUIDE, SWING 揺動ガイド	
3	FB2 - 8010 - 000		1	PLATE, PIN フロート ピン	
4	FB4 - 1350 - 000		1	ROLLER, VERTICAL PATH 縦パス ローラ	
5	FB4 - 3731 - 000		1	ROLLER, FOAM RUBBER スポンジ ローラ	
6	FB4 - 3731 - 000		1	ROLLER, FOAM RUBBER スポンジ ローラ	
7	FB4 - 3732 - 000		2	ARM, PRESSURE 加圧アーム	
8	FB4 - 3741 - 020		1	GUIDE, CURL カール付けガイド	
9	FB4 - 3773 - 000		1	HOOK, MULTI DOOR マルチ扉フック	
10	FB4 - 3814 - 000		2	ARM, PRESSURE 加圧アーム	
11	FB4 - 3816 - 000		2	SHAFT, PRESSURE 加圧軸	
12	FB4 - 3817 - 000		2	ARM, PRESSURE RELEASE 圧解除アーム	
13	FB4 - 3822 - 000		1	PLATE, HOLDER, FRONT 固定板 (前)	
14	FB4 - 3823 - 000		1	PLATE, HOLDER, REAR 固定板 (後)	
15	FB4 - 5093 - 020		1	PLATE, HORIZON. PATH GROUNDING 横パス アース板	
16	FB4 - 7839 - 000		1	PLATE, SHAFT STOP 軸止め板	
17	FB5 - 8723 - 000		1	GUIDE, VERTICAL PASS 縦パス ガイド	
18	FB6 - 0529 - 000		1	GUIDE, VERTICAL PATH, 2 縦パス ガイド (2)	
19	FF5 - 7667 - 000		1	ARM, RELEASE, REAR 解除アーム (後)	
20	FF5 - 8141 - 000		1	GUIDE, DELIVERY 排紙ガイド	
20 A	FB4 - 3743 - 000		1	SHEET, GUIDE ガイド シート	
21	FF5 - 8147 - 000		1	ARM, RELEASE, FRONT 解除アーム (前)	
22	FF5 - 8194 - 000		1	MOUNT, PAPER SENSOR 紙検知台	
23	FF6 - 1516 - 000		1	MOUNT, VERTICAL PATH 縦パス センサ台	
24	FG6 - 1867 - 000		1	CABLE, MULTI CURL INLET SENSOR マルチ カール付け入口センサ束線	J222,274
25	FG6 - 2305 - 000		1	CURL SENSOR UNIT カール付けセンサ ユニット	
25 A	FH7 - 7462 - 000		1	PHOTO-INTERRUPTER フォトインタラプタ	PS35 J274
26	FG6 - 2331 - 000		1	CABLE, PATH SENSOR CONNECTING 縦パス センサ中継束線	J303,304
27	FG6 - 8620 - 000		1	CABLE, WRITING SENSOR 書き込みセンサ束線	J901,902

FIGURE & KEY NO.	PART NUMBER	RANK	QTY	DESCRIPTION	SERIAL NUMBER / REMARKS
102 - 28	FH7 - 7394 - 000		1	PHOTO-INTERRUPTER フォトインタラプタ	PS60 J902
29	FH7 - 7462 - 000		1	PHOTO-INTERRUPTER フォトインタラプタ	PS49 J304
30	FS2 - 0566 - 000		1	GEAR, 18T 18T ギア	
31	FS2 - 0566 - 000		1	GEAR, 18T 18T ギア	
32	FS5 - 0514 - 000		1	GEAR, 20T 20T ギア	
33	FS5 - 6582 - 000		2	COLLAR カラー	
34	FS5 - 6582 - 000		2	COLLAR カラー	
35	FS6 - 2825 - 000		2	SPRING, TENSION ヒツバリ バネ	
36	FS6 - 2828 - 000		2	SPRING, TENSION ヒツバリ バネ	
37	FS6 - 2888 - 000		2	SPRING, TENSION ヒツバリ バネ	
38	FS6 - 2889 - 000		2	SPRING, TENSION ヒツバリ バネ	
39	VS1 - 5057 - 003		1	CONNECTOR, SNAP TIGHT チュウケイ コネクタ	J222
40	WT2 - 0184 - 000		1	BUSHING ブッシング	
41	XA9 - 0628 - 000		4	SCREW,RS,M4X8 RS タイト ネジ	
42	XA9 - 0628 - 000		1	SCREW,RS,M4X8 RS タイト ネジ	
43	XA9 - 0643 - 000		AR	SCREW,RS,M4X10 RS タイト ネジ	
44	XG3 - 6012 - 405		2	BEARING, BALL ボール ベアリング	
45	XG3 - 6012 - 405		2	BEARING, BALL ボール ベアリング	
46	XG9 - 0249 - 000		1	BEARING, BALL ボール ベアリング	
47	XG9 - 0250 - 000		2	BEARING, BALL ボール ベアリング	
48	XG9 - 0250 - 000		1	BEARING, BALL ボール ベアリング	
49	XG9 - 0250 - 000		4	BEARING, BALL ボール ベアリング	
501	XB1 - 2300 - 609		1	SCREW,MACH.,TRUSS HEAD,M3X6 バインド ネジ	
502	XB1 - 2300 - 609		3	SCREW,MACH.,TRUSS HEAD,M3X6 バインド ネジ	
503	XB1 - 2300 - 609		5	SCREW,MACH.,TRUSS HEAD,M3X6 バインド ネジ	
504	XB1 - 2400 - 609		4	SCREW,MACH.,TRUSS HEAD,M4X6 バインド ネジ	
505	XD1 - 1106 - 218		2	SHIM ヒョウジュン ワッシャ	
506	XD1 - 1106 - 223		2	SHIM ヒョウジュン ワッシャ	
507	XD2 - 1100 - 502		8	RING,E E リング	
508	XD2 - 1100 - 502		4	RING,E E リング	

FIGURE & KEY NO.	PART NUMBER	R A N K	Q' T Y	DESCRIPTION	SERIAL NUMBER / REMARKS
102 - 509	XD2 - 1100 - 642		3	RING,E E リング	
510	XD2 - 1100 - 642		3	RING,E E リング	
511	XD2 - 1100 - 642		4	RING,E E リング	
512	XD3 - 1200 - 142		2	PIN,SPRING スプリング ピン	
513	XD3 - 1200 - 142		2	PIN,SPRING スプリング ピン	
514	XD3 - 2200 - 122		1	PIN,DOWEL ヘイコウ ピン	
515	XD3 - 2200 - 122		1	PIN,DOWEL ヘイコウ ピン	
516	XD3 - 2200 - 122		1	PIN,DOWEL ヘイコウ ピン	

FIGURE 103 INTERNAL COMPONENTS 2

本体機械内部 (2)

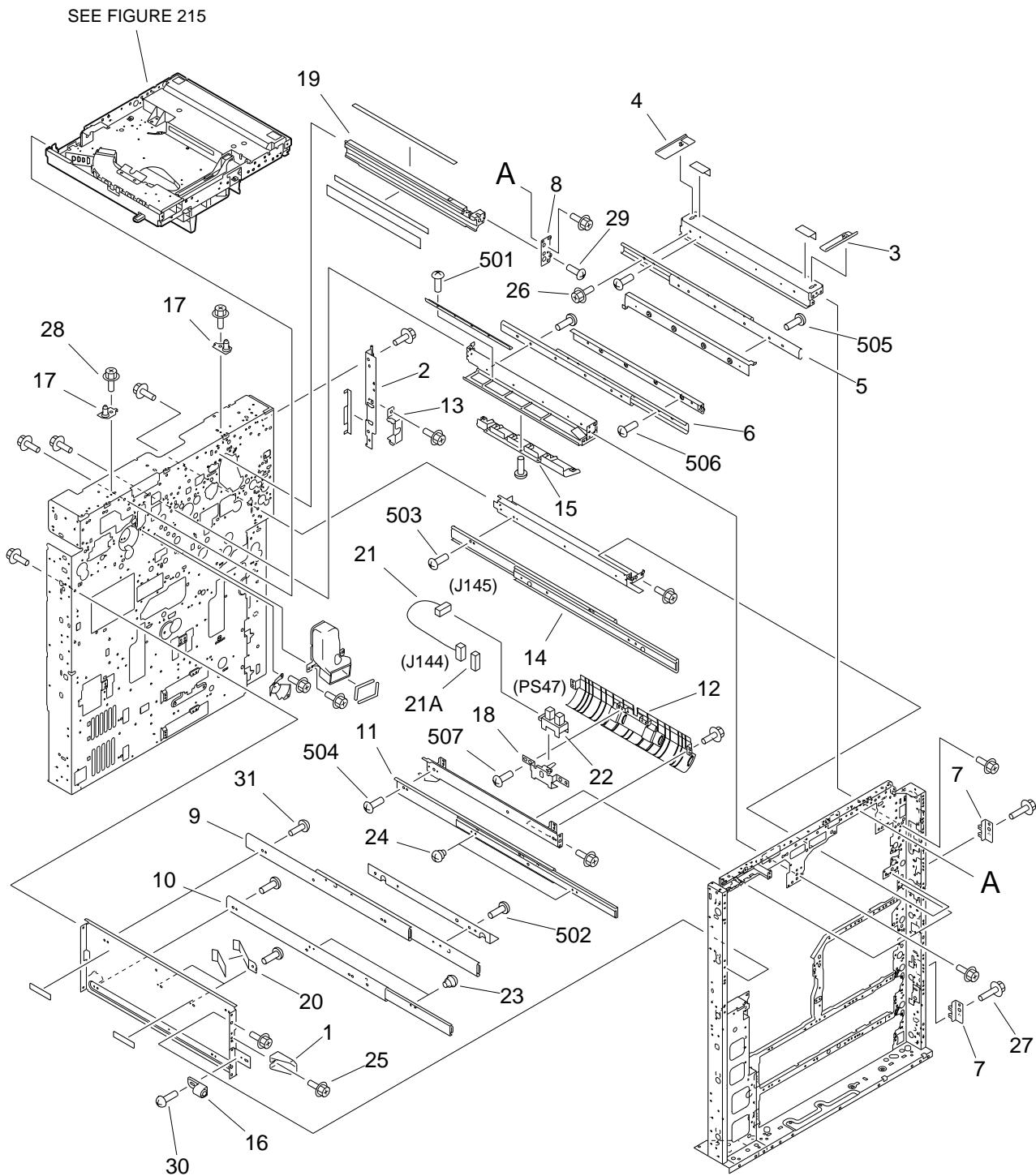

FIGURE & KEY NO.	PART NUMBER	RANK	QTY	DESCRIPTION	SERIAL NUMBER / REMARKS
103 -	NPN		RF	INTERNAL COMPONENTS 2 本体機械内部 (2)	
1	FB2 - 8041 - 000		1	BLOCK, CLOSE クロ - ズ ブロック	
2	FB4 - 1333 - 000		1	HINGE, MULTI DOOR マルチ扉ヒンジ	
3	FB4 - 1410 - 000		1	RAIL, SLIDE, FRONT スライド レール (前)	
4	FB4 - 1411 - 000		1	RAIL, SLIDE, REAR スライド レール (後)	
5	FB4 - 1418 - 000		1	RAIL, SLIDE スライド レール	
6	FB4 - 1418 - 000		1	RAIL, SLIDE スライド レール	
7	FB4 - 1421 - 000		2	MOUNT, LATCH ラッチ台	
8	FB4 - 1957 - 000		1	PLATE, RAIL POSITIONING レール位置決め板	
9	FB4 - 2041 - 000		1	RAIL, SLIDE, FIXING/FEEDER スライド レール (定着 / 搬送)	
10	FB4 - 2042 - 000		1	RAIL, SLIDE, DUPLEXING スライド レール (両面)	
11	FB4 - 2042 - 000		1	RAIL, SLIDE, DUPLEXING スライド レール (両面)	
12	FB4 - 3811 - 000		1	GUIDE, VERTICAL PATH レジ前縦バス ガイド	
13	FB4 - 7833 - 000		1	COVER, CONNECTOR, MULTI コネクタ カバー (マルチ)	
14	FB4 - 7845 - 000		1	RAIL, SLIDE, FIXING/FEEDER スライド レール (定着 / 搬送)	
15	FB5 - 6862 - 000		1	DUCT, AIR BLOW エア吹き付けダクト	
16	FF5 - 2930 - 000		1	MOUNT, MAGNET マグネット台	
17	FF5 - 7655 - 000		2	PLATE, LENS MOUNT POSITIONING レンズ台位置決め板	
18	FF5 - 8194 - 000		1	MOUNT, PAPER SENSOR 紙検知台	
19	FF5 - 8661 - 000		1	RAIL, PRIMARY, RIGHT 一次レール (右)	
20	FF5 - 8895 - 030		2	SPRING, LEAF イタ バネ	
21	FG6 - 1896 - 000		1	CABLE, PATH SENSOR CONNECTING 縦バス センサ中継束線	J144,145
21 A	VS1 - 5057 - 003		1	CONNECTOR, SNAP TIGHT チュウケイ コネクタ	J144
22	FH7 - 7462 - 000		1	PHOTO-INTERRUPTER フォトインタラプタ	PS47 J145
23	FS2 - 9343 - 000		2	SCREW, STEPPED, M4 段ビス	
24	FS2 - 9343 - 000		2	SCREW, STEPPED, M4 段ビス	
25	XA9 - 0628 - 000		2	SCREW, RS, M4X8 RS タイト ネジ	
26	XA9 - 0628 - 000		2	SCREW, RS, M4X8 RS タイト ネジ	
27	XA9 - 0630 - 000		2	SCREW, RS, M4X10 RS タイト ネジ	
28	XA9 - 0643 - 000		AR	SCREW, RS, M4X10 RS タイト ネジ	

FIGURE & KEY NO.	PART NUMBER	RANK	QTY	DESCRIPTION	SERIAL NUMBER / REMARKS
103 - 29	XA9 - 0915 - 000		1	SCREW,M3X6 タイト ネジ	
30	XA9 - 0924 - 000		1	SCREW,W/WASHER,M3X8 パネツキ バインド ネジ	
31	XA9 - 1331 - 000		3	SCREW,MACH.,TRUSS HEAD,M4X4 バインド ネジ	
501	XB1 - 2300 - 609		5	SCREW,MACH.,TRUSS HEAD,M3X6 バインド ネジ	
502	XB1 - 2400 - 409		6	SCREW,MACH.,TRUSS HEAD,M4X4 バインド ネジ	
503	XB1 - 2400 - 409		3	SCREW,MACH.,TRUSS HEAD,M4X4 バインド ネジ	
504	XB1 - 2400 - 409		3	SCREW,MACH.,TRUSS HEAD,M4X4 バインド ネジ	
505	XB1 - 2400 - 609		8	SCREW,MACH.,TRUSS HEAD,M4X6 バインド ネジ	
506	XB1 - 2400 - 609		8	SCREW,MACH.,TRUSS HEAD,M4X6 バインド ネジ	
507	XB1 - 2400 - 609		2	SCREW,MACH.,TRUSS HEAD,M4X6 バインド ネジ	

FIGURE 104 INTERNAL COMPONENTS 3
 本体機械内部 (3)

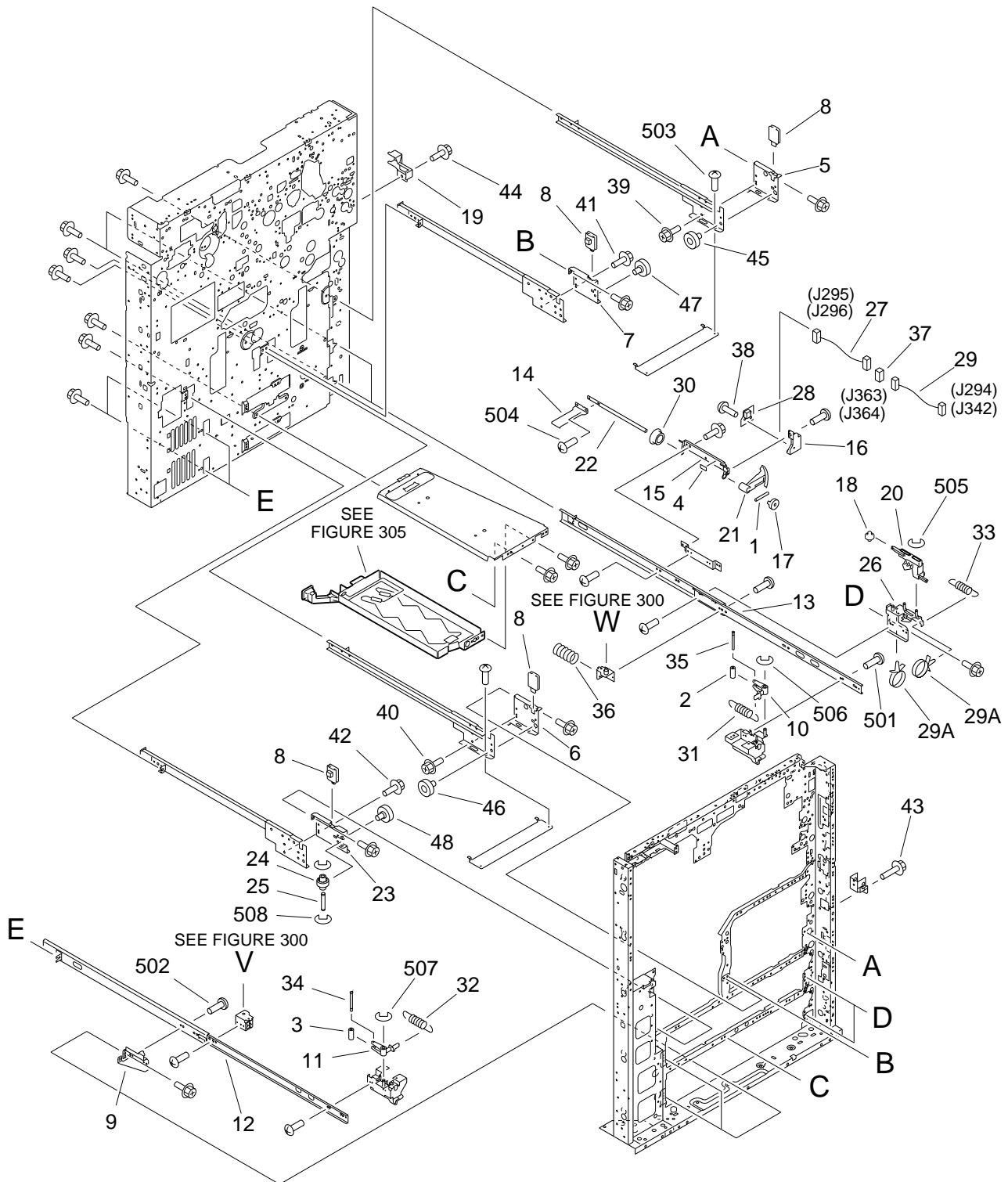

FIGURE & KEY NO.	PART NUMBER	RANK	QTY	DESCRIPTION	SERIAL NUMBER / REMARKS
104 -	NPN		RF	INTERNAL COMPONENTS 3 本体機械内部 (3)	
1	FA5 - 2924 - 000		1	PIN,DOWEL ヘイコウ ピン	
2	FA9 - 1969 - 000		1	ROLLER, TRANSFER テンシヤ コロ	
3	FA9 - 1969 - 000		2	ROLLER, TRANSFER テンシヤ コロ	
4	FA9 - 3822 - 000		1	LABEL, DISCRIMINATE 識別ラベル	
5	FB2 - 7887 - 040		1	SUPPORT, RIGHT RAIL 右レール支持板	
6	FB2 - 7887 - 040		1	SUPPORT, RIGHT RAIL 右レール支持板	
7	FB2 - 7888 - 030		1	SUPPORT, LEFT RAIL 左レール支持板	
8	FB2 - 8033 - 020		4	BLOCK, DECK RAIL STOP デッキ レール ストップ	
9	FB3 - 9345 - 000		2	SUPPORT, RAIL, LEFT FRONT レール支板 (左前)	
10	FB3 - 9356 - 000		1	LEVER, CASSETTE, RIGHT カセット レバー (右)	
11	FB4 - 0650 - 000		2	LEVER, CASSETTE, LEFT カセット レバー (左)	
12	FB4 - 1341 - 000		2	RAIL, SLIDE, LEFT スライド レール (左)	
13	FB4 - 1342 - 000		1	RAIL, SLIDE, RIGHT スライド レール (右)	
14	FB4 - 1355 - 000		1	PLATE, LIFTING リフタ板	
15	FB4 - 2019 - 000		1	PLATE, GEAR SUPPORT 扇ギア支板	
16	FB4 - 2023 - 000		1	HOLDER, PAPER SENSOR PCB 残量検知基板ホルダ	
17	FB4 - 2024 - 000		1	COUPLING カップリング	
18	FB4 - 5335 - 000		2	ROLLER, CAM カム コロ	
19	FB4 - 7834 - 000		1	COVER, CONNECTOR, CURL コネクタ カバー (カール付け)	
20	FB5 - 3351 - 000		1	BUTTON カセット解除ボタン	
21	FB5 - 8735 - 000		1	GEAR, 16T 16T ギア	
22	FB6 - 2369 - 000		1	SHAFT, CASSETTE LIFT カセット リフタ軸	
23	FB6 - 2726 - 000		1	SUPPORT, LEFT RAIL 左レール支持板	
24	FB6 - 2727 - 000		1	ROLLER, DECK デッキ コロ	
25	FB6 - 2728 - 000		1	SHAFT, ROLLER コロ軸	
26	FF5 - 9892 - 000		1	SUPPORT, RAIL, RIGHT FRONT レール取付板 (右前)	
27	FG6 - 1906 - 000		2	CABLE, CASSETTE PAPER SENSOR カセット残量検知束線	J295,363 J296,364
28	FG6 - 1941 - 000		2	PAPER SENSOR PCB ASSEMBLY 紙残量検知回路基板	
29	FG6 - 2334 - 000		1	CABLE, CASSETTE PAPER SENSOR カセット残量検知束線	J294,363 J342,364

FIGURE & KEY NO.	PART NUMBER	RANK	QTY	DESCRIPTION	SERIAL NUMBER / REMARKS
104 - 29A	WT2 - 5178 - 000		2	CLIP, CABLE ロッキング ワイヤ サドル	
30	FS5 - 1787 - 000		1	BUSHING ブッシング	
31	FS6 - 2667 - 000		1	SPRING, TENSION ヒツバリ バネ	
32	FS6 - 2667 - 000		2	SPRING, TENSION ヒツバリ バネ	
33	FS6 - 2847 - 000		1	SPRING, TENSION ヒツバリ バネ	
34	FS6 - 4243 - 000		1	SHAFT, ROLLER コ口軸	
35	FS6 - 4243 - 000		2	SHAFT, ROLLER コ口軸	
36	FS7 - 2532 - 000		1	SPRING, COMPRESSION アッシュク バネ	
37	VS1 - 5057 - 003		2	CONNECTOR, SNAP TIGHT チュウケイ コネクタ	J363,364
38	XA9 - 0596 - 000		1	SCREW,P,M3X6 P タイト ネジ	
39	XA9 - 0628 - 000		1	SCREW,RS,M4X8 RS タイト ネジ	
40	XA9 - 0628 - 000		1	SCREW,RS,M4X8 RS タイト ネジ	
41	XA9 - 0628 - 000		1	SCREW,RS,M4X8 RS タイト ネジ	
42	XA9 - 0628 - 000		1	SCREW,RS,M4X8 RS タイト ネジ	
43	XA9 - 0630 - 000		1	SCREW,RS,M4X10 RS タイト ネジ	
44	XA9 - 0643 - 000		AR	SCREW,RS,M4X10 RS タイト ネジ	
45	XG9 - 0224 - 000		1	BEARING ベアリング	
46	XG9 - 0224 - 000		1	BEARING ベアリング	
47	XG9 - 0302 - 000		1	BEARING ベアリング	
48	XG9 - 0302 - 000		1	BEARING ベアリング	
501	XB1 - 2400 - 409		7	SCREW,MACH.,TRUSS HEAD,M4X4 バインド ネジ	
502	XB1 - 2400 - 409		10	SCREW,MACH.,TRUSS HEAD,M4X4 バインド ネジ	
503	XB1 - 2400 - 409		4	SCREW,MACH.,TRUSS HEAD,M4X4 バインド ネジ	
504	XB1 - 2400 - 609		3	SCREW,MACH.,TRUSS HEAD,M4X6 バインド ネジ	
505	XD2 - 1100 - 402		2	RING,E E リング	
506	XD2 - 1100 - 502		2	RING,E E リング	
507	XD2 - 1100 - 502		2	RING,E E リング	
508	XD2 - 1100 - 502		2	RING,E E リング	

FIGURE 105 INTERNAL COMPONENTS 4
 本体機械内部 (4)

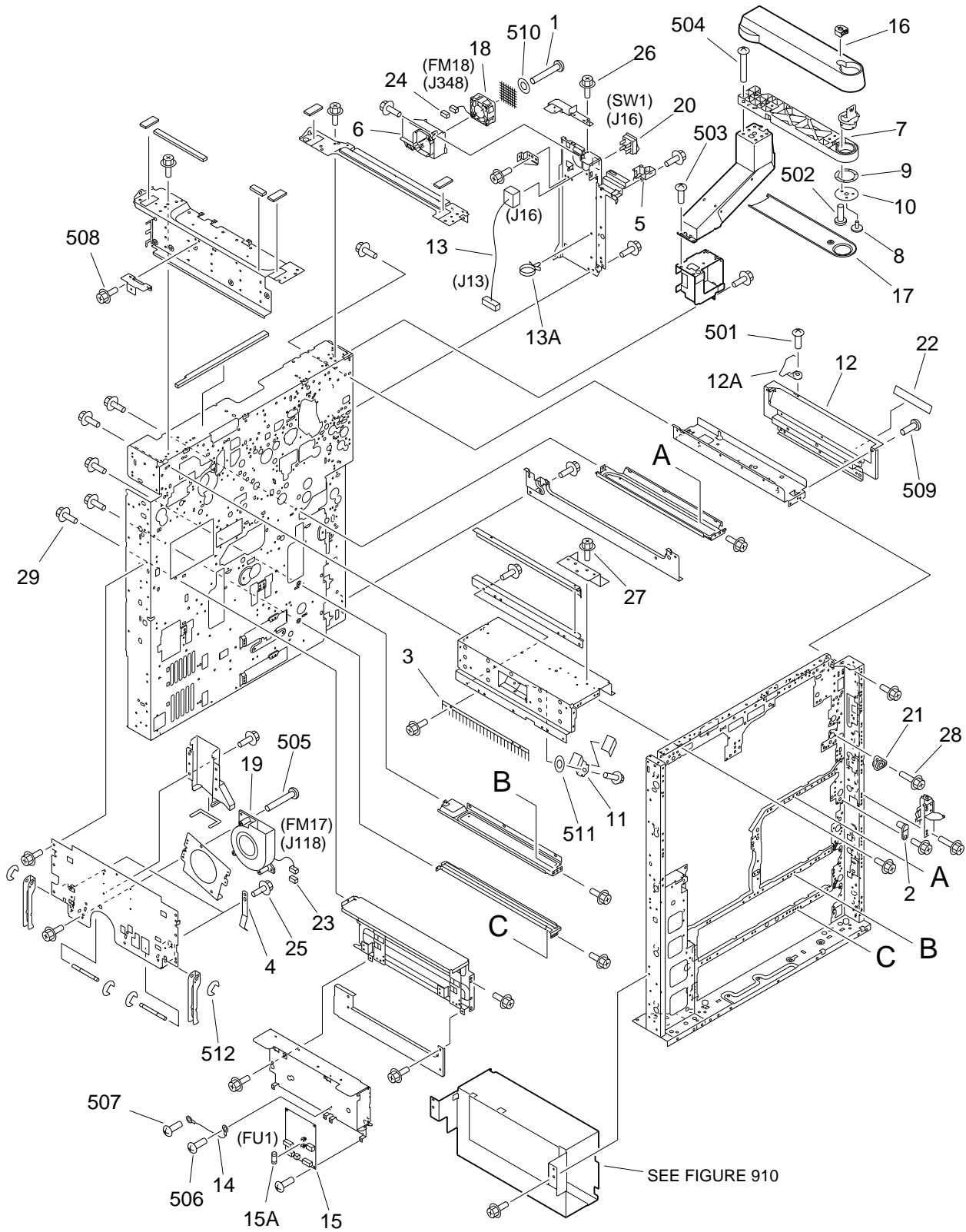

FIGURE & KEY NO.	PART NUMBER	RANK	QTY	DESCRIPTION	SERIAL NUMBER / REMARKS
105 -	NPN		RF	INTERNAL COMPONENTS 4 本体機械内部 (4)	
1	FA9 - 3622 - 000		2	SCREW, TAPPING, PAN HEAD, M4X35 ナベ タッピン ネジ	
2	FB2 - 8010 - 000		1	PLATE, PIN フロート ピン	
3	FB2 - 8248 - 020		1	ELIMINATOR, STATIC CHARGE 除電ブラシ	
4	FB4 - 9034 - 000		2	SPRING, LEAF 板バネ	
5	FB5 - 1840 - 000		1	COVER, CARTRIDGE CONNECTOR カートリッジ コネクタ カバー	
6	FB5 - 7048 - 000		1	DUCT, SCANNER MOTOR FAN 光学モータ ファン ダクト	
7	FB6 - 0433 - 000		1	ARM アーム	
8	FB6 - 0439 - 000		1	SCREW, M4 ネジ	
9	FB6 - 0449 - 000		1	WASHER, WAVE 波形座金	
10	FB6 - 0450 - 000		1	WASHER 座金	
11	FF5 - 7726 - 000		1	SPRING, LEAF 排紙ガイド加圧板	
12	FG6 - 1971 - 000		1	DEVELOPING SUPPORT PLATE 現像加圧板	
12 A	FB4 - 1869 - 000		1	BLOCK, SHUTTER SLIDE シャッター スライド	
13	FG6 - 7208 - 000		1	CABLE, MAIN SWITCH メイン スイッチ束線	J13,16
13 A	WT2 - 5565 - 000		5	CLAMP, CABLE ソクセン オサエ	
14	FG6 - 7221 - 000		1	CABLE, GROUNDING アース線	
15	FG6 - 7268 - 000		1	ALL DAY POWER PCB ASSEMBLY 常夜電源回路基板	
15 A	VD7 - 0642 - 001		1	FUSE, 250V 2A ヒューズ	FU1
16	FG9 - 3878 - 000		1	COVER, ARM アーム カバー	
17	FG9 - 3879 - 000		1	PANEL, ARM LOWER アーム下カバー	
18	FH6 - 1740 - 000		1	FAN ファン モータ	FM18 J348
19	FH6 - 1877 - 000		1	FAN ファン モータ	FM17 J118
20	FH7 - 6327 - 000		1	SWITCH, POWER SUPPLY 電源スイッチ	SW1 J16
21	FS5 - 1798 - 000		1	BUSHING ブッシング	
22	FS6 - 8820 - 000		1	LABEL, "WARNING LASER" レーザ注意ラベル	200/208V
	FS5 - 8623 - 000		1	LABEL, "WARNING LASER" レーザ注意ラベル	220/240V
23	VS1 - 5057 - 003		1	CONNECTOR, SNAP TIGHT チュウケイ コネクタ	J118
24	VS1 - 5057 - 004		1	CONNECTOR, SNAP TIGHT チュウケイ コネクタ	J348
25	XA9 - 0628 - 000		5	SCREW, RS, M4X8 RS タイト ネジ	

FIGURE & KEY NO.	PART NUMBER	RANK	QTY	DESCRIPTION	SERIAL NUMBER / REMARKS
105 - 26	XA9 - 0628 - 000		5	SCREW,RS,M4X8 RS タイト ネジ	
27	XA9 - 0628 - 000		9	SCREW,RS,M4X8 RS タイト ネジ	
28	XA9 - 0630 - 000		6	SCREW,RS,M4X10 RS タイト ネジ	
29	XA9 - 0643 - 000		AR	SCREW,RS,M4X10 RS タイト ネジ	
501	XB1 - 2300 - 609		1	SCREW,MACH.,TRUSS HEAD,M3X6 バインド ネジ	
502	XB1 - 2400 - 805		3	SCREW, MACHINE M4X8 (S) バインドビス (M4x8)	
503	XB1 - 2401 - 009		6	SCREW,MACH.,TRUSS HEAD,M4X10 バインド ネジ	
504	XB1 - 2401 - 409		5	SCREW,MACH.,TRUSS HEAD,M4X14 バインド ネジ	
505	XB1 - 2403 - 509		2	SCREW,MACH.,TRUSS HEAD,M4X35 バインド ネジ	
506	XB2 - 8401 - 007		4	SCREW,W/WASHER,M4X10 パネツキ バインド ネジ	
507	XB2 - 8401 - 007		5	SCREW,W/WASHER,M4X10 パネツキ バインド ネジ	
508	XB3 - 6400 - 805		2	SCREW,RS,M4X8 RS タイト ネジ	
509	XB6 - 7400 - 609		6	SCREW,TP,M4X6 TP ネジ	
510	XD1 - 1105 - 235		2	SHIM ヒョウジュン ワッシャ	
511	XD1 - 1105 - 239		1	SHIM ヒョウジュン ワッシャ	
512	XD2 - 1100 - 642		4	RING,E E リング	

FIGURE 106 MACHINE REAR PLATE 1

本体後側板(1)

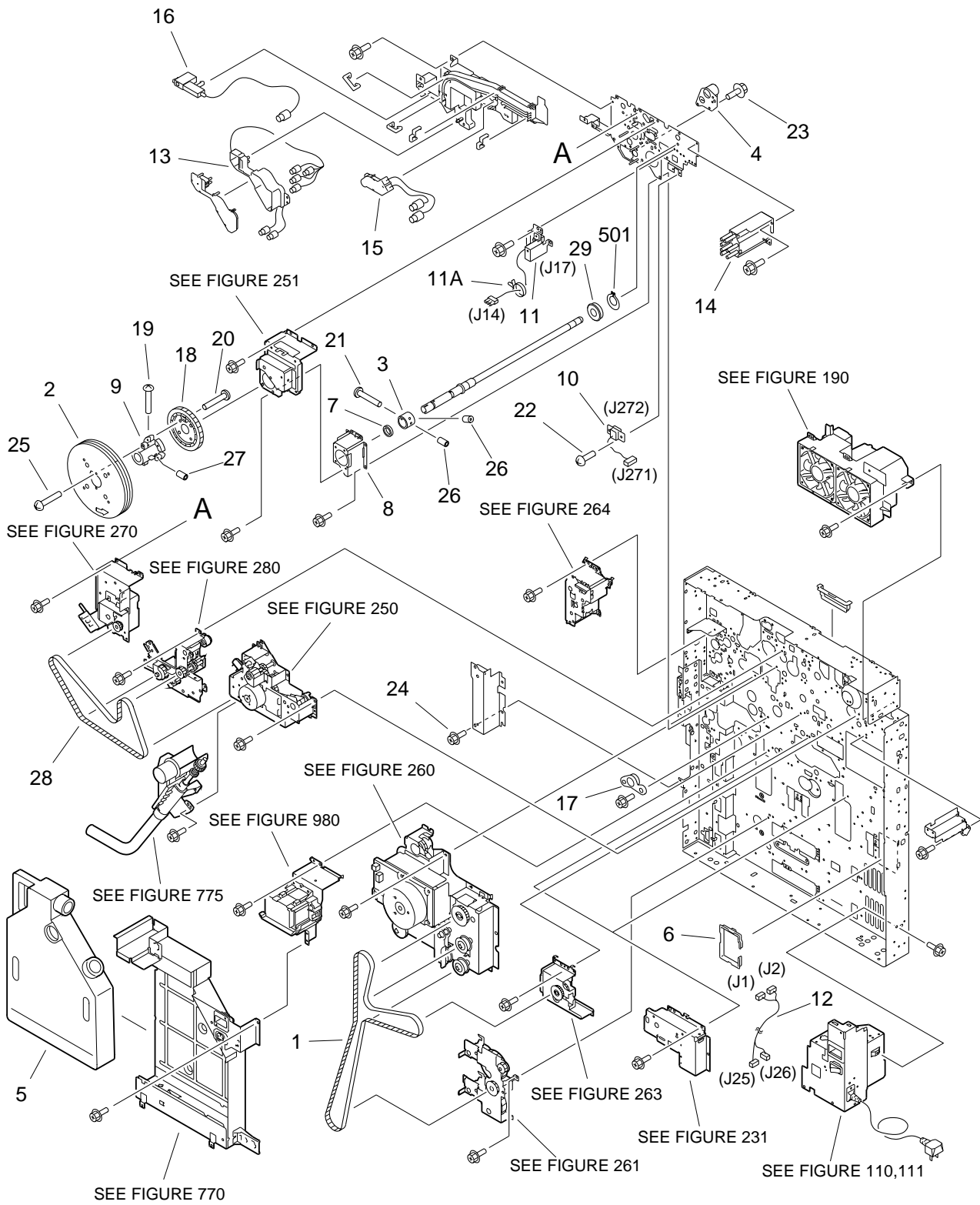

FIGURE & KEY NO.	PART NUMBER	RANK	QTY	DESCRIPTION	SERIAL NUMBER / REMARKS
106 -	NPN		RF	MACHINE REAR PLATE 1 本体後側板 (1)	
1	FB4 - 1354 - 000		1	BELT, DRIVE, PAPER PICK-UP 給紙駆動ベルト	
2	FB4 - 1750 - 000		1	FLYWHEEL フライホイール	
3	FB4 - 1753 - 000		1	COLLAR, THRUST STOP スラスト ストップ	
4	FB4 - 1781 - 000		1	HOLDER, POSITIONING, REAR 位置決めホルダ (後)	
5	FB4 - 1953 - 000		1	BOTTLE, WASTE TONER 廃トナー ボトル	
6	FB4 - 9032 - 000		1	COVER, EDGE エッジ カバー	
7	FB5 - 2596 - 000		1	SPACER, DRUM SHAFT ドラム軸スパーサ	
8	FB5 - 6882 - 000		1	SUPPORT, BEARING, REAR ベアリング支持板 (後)	
9	FB5 - 6884 - 000		1	SUPPORT, FLYWHEEL フライホイール支持台	
10	FG6 - 3569 - 000		1	CABLE, BIAS SEPARATION CLAW 分離爪バイアス束線	J271,272
11	FG6 - 7201 - 000		1	CABLE, DRUM HEATER CONNECTING ドラム ヒータ中継束線	J14,17
11 A	WT2 - 5565 - 000		4	CLAMP, CABLE ソクセン オサエ	
12	FG6 - 7211 - 000		1	CABLE, AC INPUT AC入力束線	J1,2,25,26
13	FH2 - 6807 - 000		1	HOLDER, CONNECTOR コネクタ ホルダ	
14	FH2 - 9232 - 000		1	JOINT CONNECTOR UNIT, 1 連結コネクタ (1)	
15	FH2 - 9233 - 000		1	JOINT CONNECTOR UNIT, 2 連結コネクタ (2)	
16	FH2 - 9235 - 000		1	JOINT CONNECTOR UNIT, 4 連結コネクタ (4)	
17	FS5 - 1467 - 020		1	BUSHING, 3 ブッシング (3)	
18	FS7 - 0011 - 000		1	GEAR, 90T 90T ギア	
19	XA9 - 0207 - 000		1	SCREW,M4X12 セムス ネジ	
20	XA9 - 0207 - 000		2	SCREW,M4X12 セムス ネジ	
21	XA9 - 0207 - 000		1	SCREW,M4X12 セムス ネジ	
22	XA9 - 0384 - 000		2	SCREW,TP,M3X8 TP ネジ	
23	XA9 - 0628 - 000		5	SCREW,RS,M4X8 RS タイト ネジ	
24	XA9 - 0643 - 000		AR	SCREW,RS,M4X10 RS タイト ネジ	
25	XA9 - 1090 - 000		3	SCREW,W/WASHER,M5X25 セムス ネジ	
26	XA9 - 1091 - 000		2	SETSCREW,M4X8 ロック アナツキ トメネジ	
27	XA9 - 1278 - 000		2	SETSCREW,M6X10 ロック アナツキ トメネジ	
28	XF9 - 0533 - 000		1	BELT, TIMING タイミング ベルト	

FIGURE & KEY NO.	PART NUMBER	R A N K	Q' T Y	DESCRIPTION	SERIAL NUMBER / REMARKS
106 - 29	XG9 - 0248 - 000		1	BEARING, BALL, 6004ZZNR*C3 ボール ベアリング	
501	XD2 - 3100 - 202		1	RING,C,EXTERNAL C リング(ジクヨウ)	

FIGURE 107 MACHINE REAR PLATE 2

本体後側板(2)

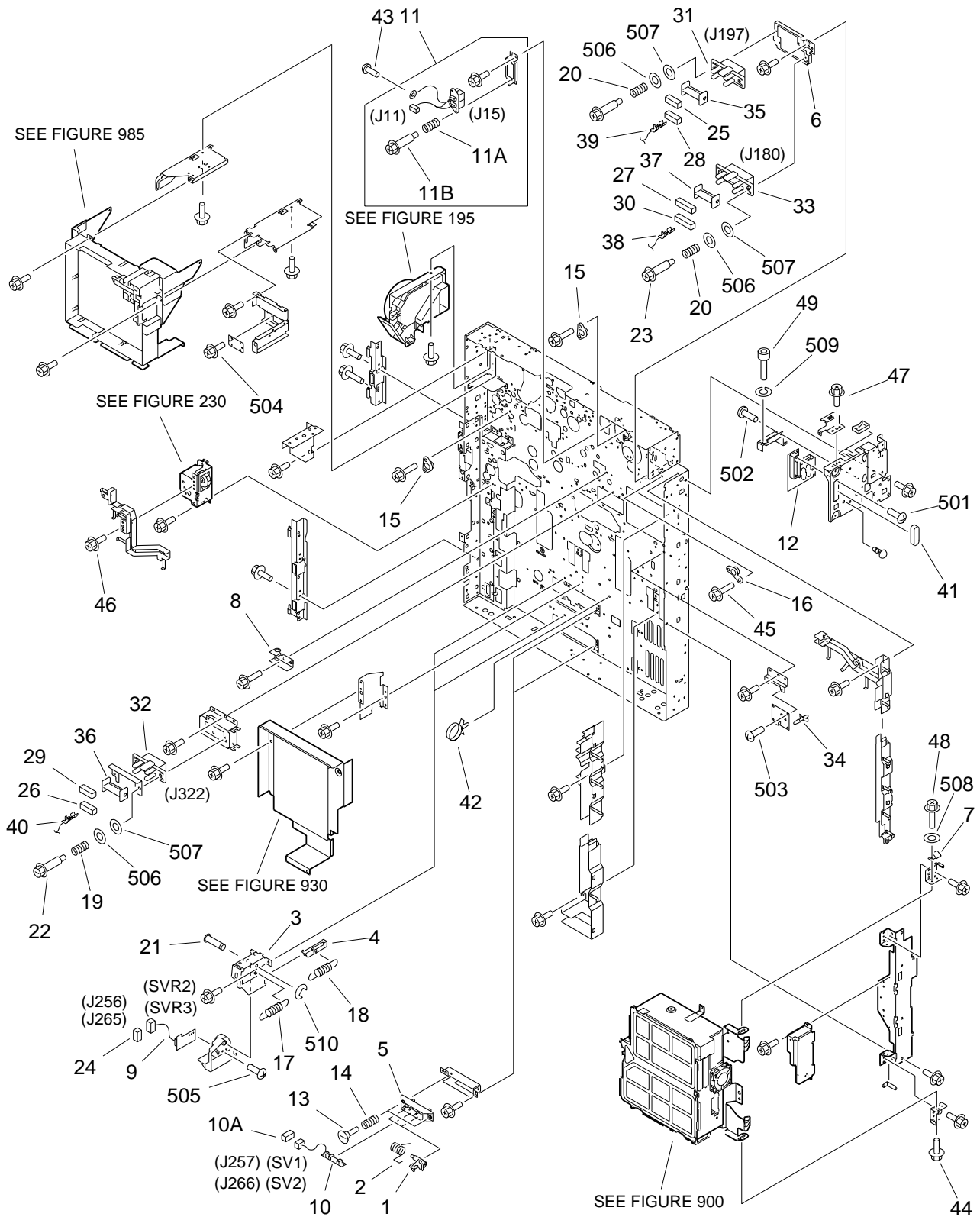

FIGURE & KEY NO.	PART NUMBER	RANK	QTY	DESCRIPTION	SERIAL NUMBER / REMARKS
107 -	NPN		RF	MACHINE REAR PLATE 2 本体後側板 (2)	
1	FB1 - 8735 - 000		4	ARM, SENSOR センサ アーム	
2	FB1 - 8737 - 000		4	SPRING, TORSION ネジリ パネ	
3	FB3 - 9362 - 000		2	MOUNT, VR HOLDER ボリューム ホルダ基台	
4	FB3 - 9363 - 000		2	SHAFT, SLIDE スライド シャフト	
5	FB3 - 9364 - 000		2	HOLDER, SWITCH スイッチ ホルダ	
6	FB4 - 1447 - 000		1	MOUNT, DC CONNECTOR, 2 DCコネクタ台 (2)	
7	FB6 - 0784 - 000		1	SPRING, LEAF, GROUNDING アース板パネ	
8	FF5 - 7665 - 000		1	HOLDER, STOP ストップ ホルダ	
9	FG5 - 1957 - 000		1	CASSETTE VR PCB ASSEMBLY カセット ボリューム回路基板	SVR2,3 J256,265
10	FG5 - 8221 - 000		1	CASSETTE SENSOR PCB ASSEMBLY カセット紙検知回路基板	SV1,2 J257,266
10 A	VS1 - 5057 - 004		2	CONNECTOR, SNAP TIGHT チュウケイ コネクタ	J257,266
11	FG6 - 1904 - 000		1	CABLE, FIXING DRAWER CONNECT 定着ドロア中継束線	J11,15
11 A	FS5 - 2964 - 000		2	SPRING, COMPRESSION アッシュク パネ	
11 B	FS5 - 9282 - 000		2	SCREW, STEPPED 段ビス	
12	FG6 - 8604 - 000		1	BICENTRO/DISPLAY PCB ASSEMBLY バイセントロ/ディスプレイ回路基板	
13	FS2 - 9327 - 000		4	SCREW, STEPPED, M4 ダン ビス	
14	FS3 - 2044 - 000		4	SPRING, COMPRESSION アッシュク パネ	
15	FS5 - 1468 - 020		2	BUSHING, 2 ブッシング (2)	
16	FS5 - 1804 - 000		1	BUSHING ブッシング	
17	FS5 - 2322 - 000		2	SPRING, TENSION ヒツパリ パネ	
18	FS5 - 2323 - 020		2	SPRING, TENSION ヒツパリ パネ	
19	FS5 - 2965 - 000		2	SPRING, COMPRESSION アッシュク パネ	
20	FS5 - 2965 - 000		4	SPRING, COMPRESSION アッシュク パネ	
21	FS5 - 7128 - 000		2	SHAFT 支持軸	
22	FS5 - 9282 - 000		2	SCREW, STEPPED 段ビス	
23	FS5 - 9282 - 000		4	SCREW, STEPPED 段ビス	
24	VS1 - 5057 - 003		2	CONNECTOR, SNAP TIGHT チュウケイ コネクタ	J256,265
25	VS1 - 6313 - 013		4	CONNECTOR, 13P, FEMALE コネクタ (メス)	J197
26	VS1 - 6313 - 016		3	CONNECTOR, 16P, FEMALE コネクタ (メス)	J322

FIGURE & KEY NO.	PART NUMBER	RANK	QTY	DESCRIPTION	SERIAL NUMBER / REMARKS
107 - 27	VS1 - 6313 - 020		2	CONNECTOR, 20P, FEMALE コネクタ (メス)	J180
28	VS1 - 6314 - 013		6	CONNECTOR, 13P, FEMALE コネクタ (メス)	J197
29	VS1 - 6314 - 016		1	CONNECTOR, 16P, FEMALE コネクタ (メス)	J322
30	VS1 - 6314 - 020		2	CONNECTOR, 20P, FEMALE コネクタ (メス)	J180
31	VS1 - 6328 - 026		1	CONNECTOR, 26P, FEMALE コネクタ (メス)	J197
32	VS1 - 6328 - 032		1	CONNECTOR, 32P, FEMALE コネクタ (メス)	J322
33	VS1 - 6328 - 040		1	CONNECTOR, 40P, FEMALE コネクタ (メス)	J180
34	VT2 - 0001 - 006		2	SUPPORT, PCB ロッキング サポート	
35	VT2 - 5161 - 026		4	HOLDER, CONNECTOR, 26P コネクタ ホルダ	J197
36	VT2 - 5161 - 032		1	HOLDER, CONNECTOR, 32P コネクタ ホルダ	J322
37	VT2 - 5161 - 040		2	HOLDER, CONNECTOR, 40P コネクタ ホルダ	J180
38	WS3 - 5607 - 000		2	SOCKET CONTACT, 20-24AWG コンタクト	J180
39	WS3 - 5607 - 000		4	SOCKET CONTACT, 20-24AWG コンタクト	J197
40	WS3 - 5607 - 000		4	SOCKET CONTACT, 20-24AWG コンタクト	J322
41	WT2 - 5546 - 000		1	COVER, DUST ダストカバー	
42	WT2 - 5565 - 000		3	CLAMP, CABLE ソクセン オサエ	
43	XA9 - 0265 - 000		1	SCREW,W/WASHER,TRUSS HEAD ザツキ バインド ネジ	
44	XA9 - 0629 - 000		3	SCREW,RS,M4X8 RS タイト ネジ	
45	XA9 - 0630 - 000		10	SCREW,RS,M4X10 RS タイト ネジ	
46	XA9 - 0643 - 000		AR	SCREW,RS,M4X10 RS タイト ネジ	
47	XA9 - 0643 - 000		1	SCREW,RS,M4X10 RS タイト ネジ	
48	XA9 - 0774 - 000		1	SCREW,RS,M4X16 RS タイト ネジ	
49	XA9 - 1131 - 000		2	SCREW,M2.6X4 DDI - Sコネクタ用六角ねじ	
501	XB1 - 2300 - 506		2	SCREW,MACH.,TRUSS HEAD,M3X5 バインド ネジ	
502	XB1 - 2400 - 606		4	SCREW,MACH.,TRUSS HEAD,M4X6 バインド ネジ	
503	XB1 - 2400 - 607		2	SCREW,MACH.,TRUSS HEAD,M4X6 バインド ネジ	
504	XB3 - 6300 - 800		2	SCREW,RS,M3X8 RS タイト ネジ	
505	XB4 - 7400 - 809		2	SCREW,TAPPING,TRUSS HEAD,M4X8 バインド タッピン ネジ	
506	XD1 - 1103 - 633		4	SHIM ヒョウジュン ワッシャ	
507	XD1 - 1104 - 133		4	SHIM ヒョウジュン ワッシャ	

FIGURE & KEY NO.	PART NUMBER	R A N K	Q' T Y	DESCRIPTION	SERIAL NUMBER / REMARKS
107 - 508	XD1 - 1106 - 235		1	SHIM ヒヨウジュン ワッシャ	
509	XD1 - 3100 - 307		2	WASHER,SPRING パネ ザガネ	
510	XD2 - 1100 - 502		2	RINGE E リング	

FIGURE 108 MACHINE BOTTOM PLATE

本体底板

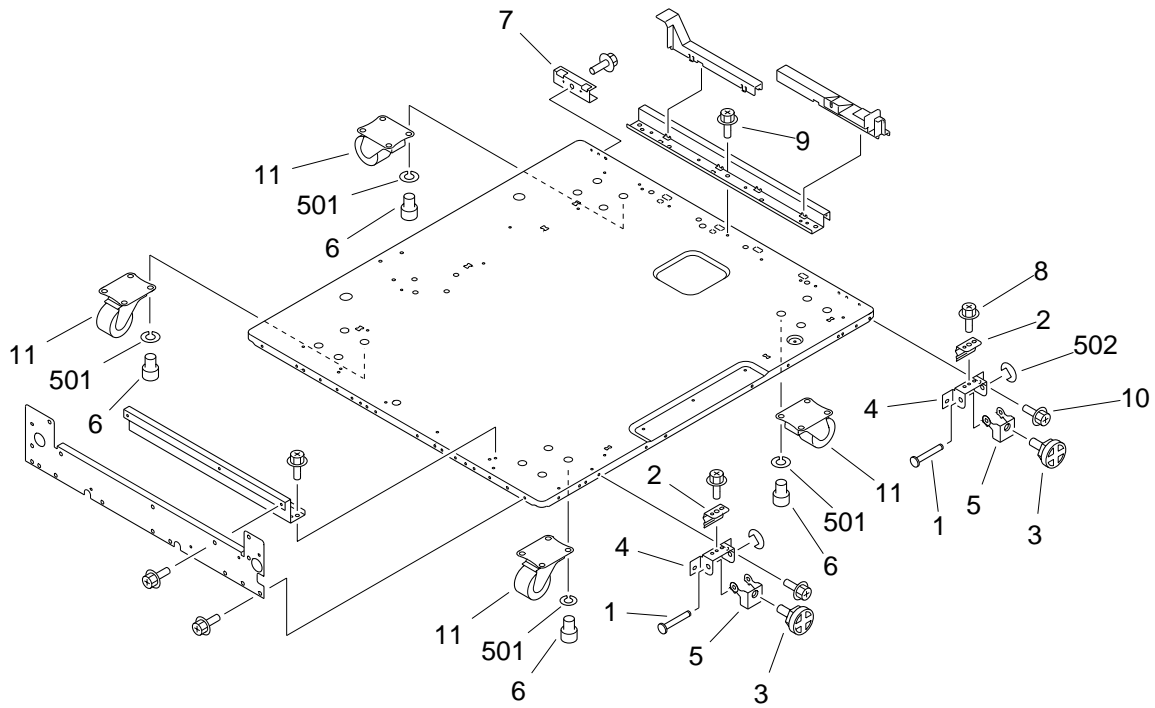
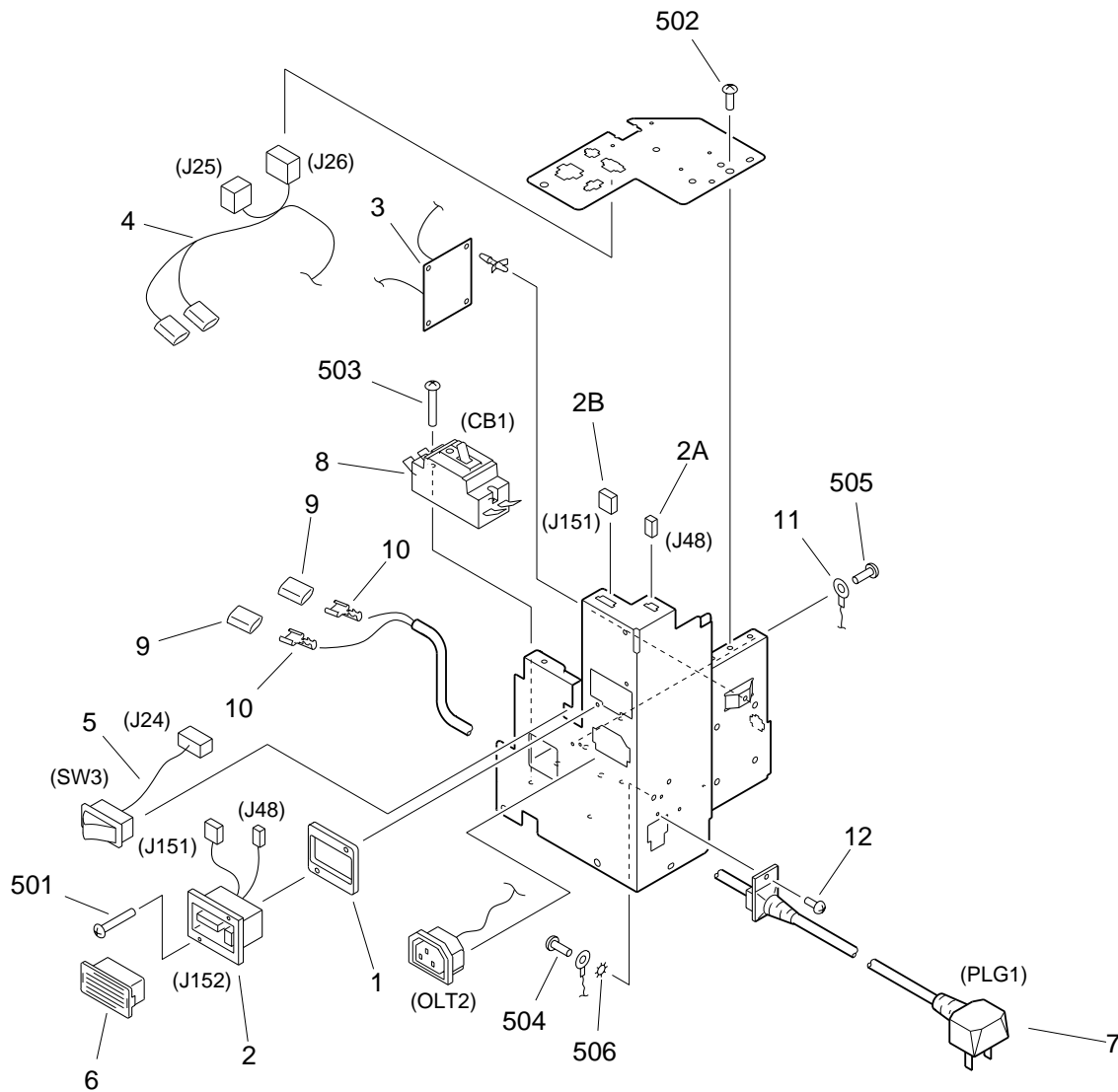

FIGURE & KEY NO.	PART NUMBER	RANK	QTY	DESCRIPTION	SERIAL NUMBER / REMARKS
108 -	NPN		RF	MACHINE BOTTOM PLATE 本体底板	
1	FB2 - 7899 - 000		2	SHAFT, PIVOT, FRONT アジャスタ揺動軸 (前)	
2	FB2 - 7900 - 000		2	SPRING, LEAF 板バネ	
3	FB2 - 8506 - 000		2	ADJUSTER アジャスタ	
4	FB4 - 1334 - 000		2	PLATE, ADJUSTING, FRONT アジャスタ固定板	
5	FB4 - 1339 - 000		2	PLATE, PIVOT アジャスタ揺動板	
6	FB4 - 1340 - 000		16	SCREW, ALLEN HEAD, M8X10 ロックナット アナツキ ボルト	
7	FB4 - 7846 - 000		1	PLATE, WASTE TONER FIXED 廃トナー固定板	
8	XA9 - 0628 - 000		2	SCREW, RS, M4X8 RS タイト ネジ	
9	XA9 - 0628 - 000		10	SCREW, RS, M4X8 RS タイト ネジ	
10	XA9 - 0643 - 000		AR	SCREW, RS, M4X10 RS タイト ネジ	
11	XZ9 - 0367 - 000		4	CASTER キャスタ	
501	XD1 - 3100 - 805		16	WASHER, SPRING バネ ザガネ	
502	XD2 - 1100 - 502		2	RING, E E リング	

POWER CORD TERMINAL ASSEMBLY
 (200V)
 電源コード台部
 (200V)



NOTE: This assembly does not include the part shown with key No. 6.
 注: このユニットにKey No. 6の部品は含まれません。

FIGURE & KEY NO.	PART NUMBER	RANK	QTY	DESCRIPTION	SERIAL NUMBER / REMARKS
110 -	FG6 - 8005 - 000		1	POWER CORD TERMINAL ASSEMBLY 電源コード台部	200V
1	FB4 - 1542 - 000		1	SPACER, LATTICE CABLE ラティス束線スペーサ	
2	FG6 - 1813 - 000		1	CABLE, LATTICE, FINISHER フィニッシャ ラティス束線	J48,151,152
2A	VS1 - 5057 - 002		1	CONNECTOR, SNAP TIGHT チュウケイ コネクタ	J48
2B	VS1 - 5057 - 005		1	CONNECTOR, SNAP TIGHT チュウケイ コネクタ	J151
3	FG6 - 6512 - 000		1	CAPACITOR PCB ASSEMBLY コンデンサ回路基板	
4	FG6 - 7206 - 000		1	CABLE, OUTLET アウトレット束線	OLT2 J25,26
5	FG6 - 7207 - 000		1	CABLE, ENVIRONMENT SWITCH 環境スイッチ束線	SW3 J24
6	FH2 - 6552 - 000		1	COVER, CONNECTOR コネクタ カバー	SEE NOTE
7	FH2 - 6877 - 000		1	CORD, POWER 電源コード	PLG1
8	FH7 - 7574 - 000		1	BREAKER, ELECTRIC LEAKAGE 漏電ブレーカ	CB1
9	WS3 - 5610 - 000		2	CONNECTOR, 1P, FEMALE コネクタ (メス)	
10	WS3 - 5613 - 000		2	SOCKET CONTACT, 10-14AWG ソケット コンタクト	
11	WT1 - 0580 - 000		1	TERMINAL, RING マルガタ タンシ	
12	XA9 - 0739 - 000		1	SCREW,TP,M4X8 タッピン ネジ	
501	XB1 - 2301 - 407		2	SCREW,MACH.,TRUSS HEAD,M3X14 バインド ネジ	
502	XB1 - 2400 - 606		2	SCREW,MACH.,TRUSS HEAD,M4X6 バインド ネジ	
503	XB1 - 2402 - 009		2	SCREW,MACH.,TRUSS HEAD,M4X20 バインド ネジ	
504	XB1 - 2500 - 606		1	SCREW,MACH.,TRUSS HEAD,M5X6 バインド ネジ	
505	XB2 - 7400 - 606		1	SCREW,W/WASHER,M4X6 バネツキ バインド ネジ	
506	XD1 - 4200 - 502		1	WASHER,TOOTHED LOCK ハツキ ザガネ	

POWER CORD TERMINAL ASSEMBLY
 (208/220/240V)
 電源コード台部
 (208 / 220 / 240V)

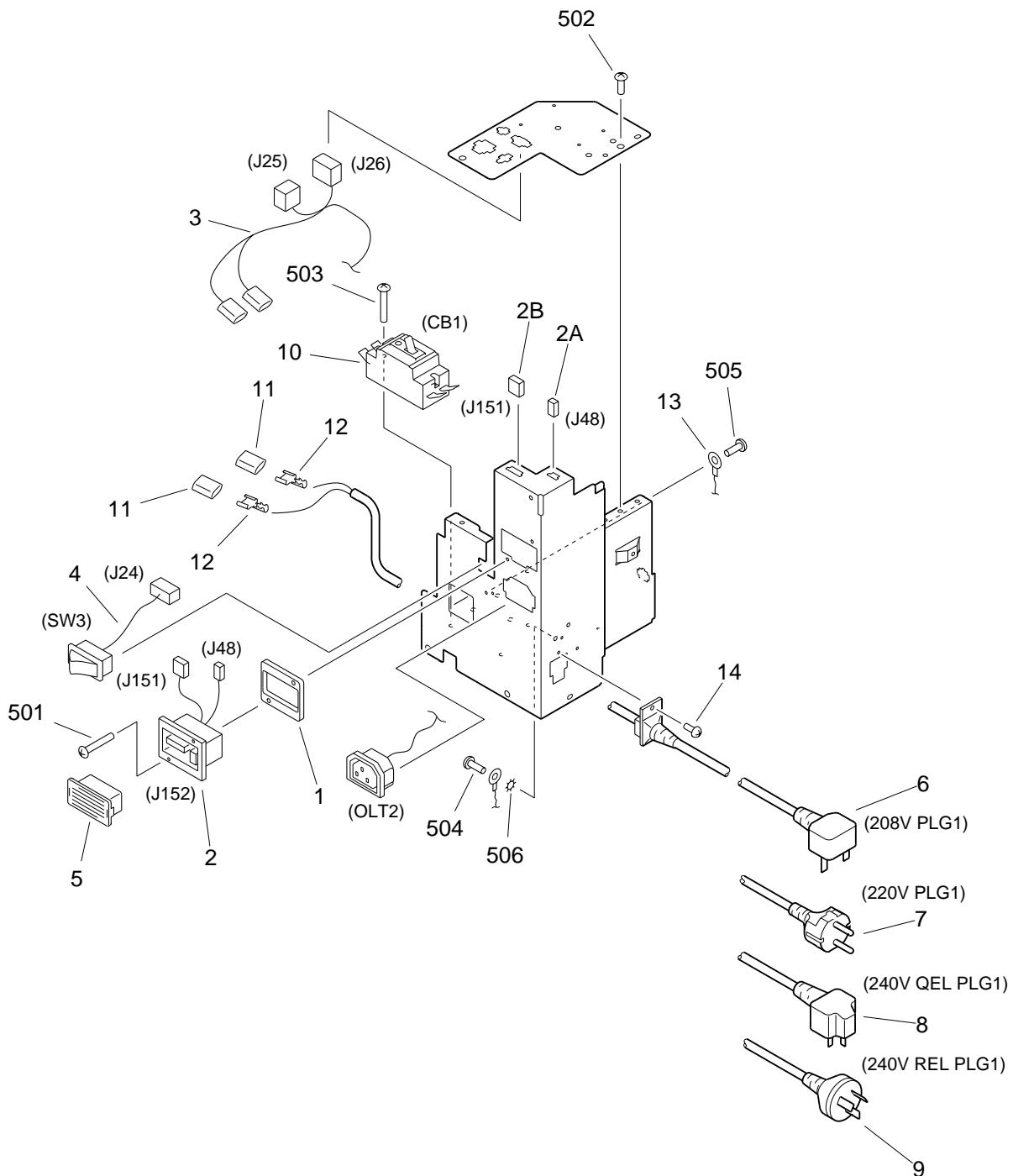

NOTE: This assembly does not include the part shown with key No.5.
 注：このユニットにKey No. 5の部品は含まれません。

FIGURE & KEY NO.	PART NUMBER	RANK	QTY	DESCRIPTION	SERIAL NUMBER / REMARKS
111 -	FG6 - 7270 - 000		1	POWER CORD TERMINAL ASSEMBLY 電源コード台部	208V
	FG6 - 7271 - 000		1	POWER CORD TERMINAL ASSEMBLY 電源コード台部	220V
	FG6 - 7319 - 000		1	POWER CORD TERMINAL ASSEMBLY 電源コード台部	240V QEL
	FG6 - 7320 - 000		1	POWER CORD TERMINAL ASSEMBLY 電源コード台部	240V REL
	1	FB4 - 1542 - 000		1	SPACER, LATTICE CABLE ラティス束線スペーサ
2	FG6 - 1813 - 000		1	CABLE, LATTICE, FINISHER フィニッシャ ラティス束線	J48,151,152
2 A	VS1 - 5057 - 002		1	CONNECTOR, SNAP TIGHT チュウケイ コネクタ	J48
2 B	VS1 - 5057 - 005		1	CONNECTOR, SNAP TIGHT チュウケイ コネクタ	J151
3	FG6 - 7206 - 000		1	CABLE, OUTLET アウトレット束線	OLT2 J25,26
4	FG6 - 7207 - 000		1	CABLE, ENVIRONMENT SWITCH 環境スイッチ束線	SW3 J24
5	FH2 - 6552 - 000		1	COVER, CONNECTOR コネクタ カバー	SEE NOTE
6	FH2 - 6901 - 000		1	CORD, POWER, 250V 15A 電源コード	208V PLG1
7	FH2 - 6919 - 000		1	CORD, POWER, 250V 16A 電源コード	220V PLG1
8	FH2 - 6920 - 000		1	CORD, POWER, 250V 13A 電源コード	240V QEL PLG1
9	FH2 - 6921 - 000		1	CORD, POWER, 250V 15A 電源コード	240V REL PLG1
10	FH7 - 7574 - 000		1	BREAKER, ELECTRIC LEAKAGE 漏電ブレーカ	CB1
11	WS3 - 5610 - 000		2	CONNECTOR, 1P, FEMALE コネクタ (メス)	
12	WS3 - 5613 - 000		2	SOCKET CONTACT, 10-14AWG ソケット コンタクト	208V
	WS3 - 5612 - 000		2	SOCKET CONTACT ソケット コンタクト	220/240V
13	WT1 - 0580 - 000		1	TERMINAL, RING マルガタ タンシ	
14	XA9 - 0739 - 000		1	SCREW, TP, M4X8 タッピン ネジ	
501	XB1 - 2301 - 407		2	SCREW, MACH., TRUSS HEAD, M3X14 バインド ネジ	
502	XB1 - 2400 - 606		2	SCREW, MACH., TRUSS HEAD, M4X6 バインド ネジ	
503	XB1 - 2402 - 009		2	SCREW, MACH., TRUSS HEAD, M4X20 バインド ネジ	
504	XB1 - 2500 - 606		1	SCREW, MACH., TRUSS HEAD, M5X6 バインド ネジ	
505	XB2 - 7400 - 606		1	SCREW, W/WASHER, M4X6 パネツキ バインド ネジ	
506	XD1 - 4200 - 502		1	WASHER, TOOTHED LOCK ハツキ ザガネ	

FIGURE 120 DOOR SWITCH MOUNT ASSEMBLY ドアスイッチ台部

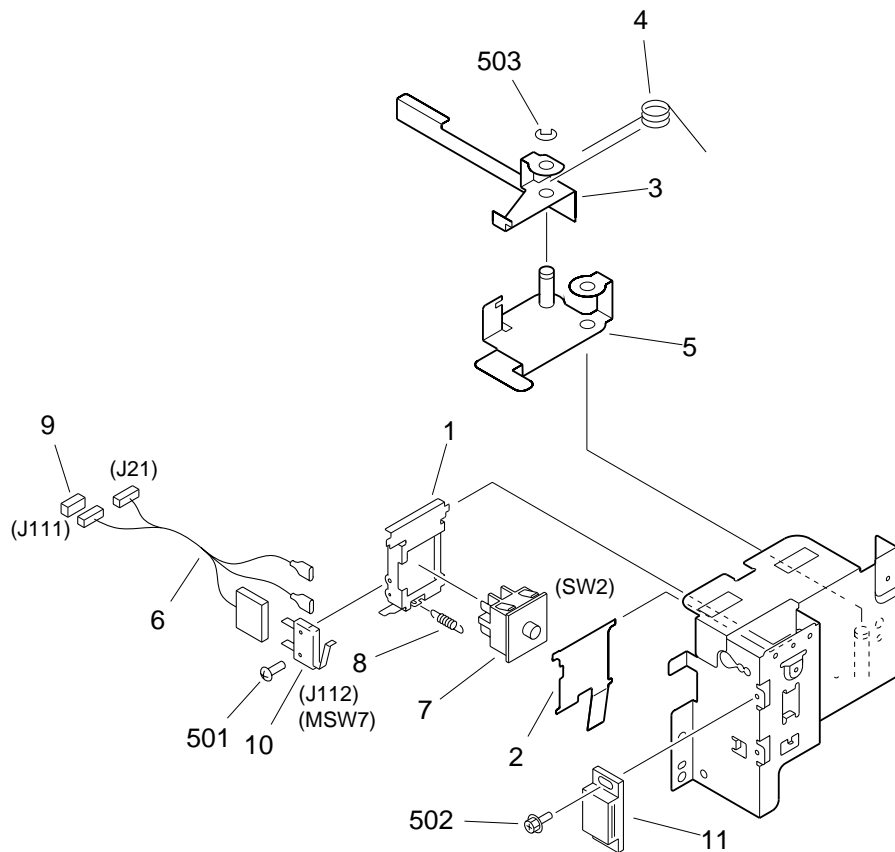

NOTE: This assembly does not include the part shown with key No.9.
注：このユニットにKey No. 9の部品は含まれません。

FIGURE & KEY NO.	PART NUMBER	R A N K	Q' T Y	DESCRIPTION	SERIAL NUMBER / REMARKS
120 -	FG6 - 7294 - 000		1	DOOR SWITCH MOUNT ASSEMBLY ドア スイッチ台部	
1	FB4 - 1432 - 000		1	HOLDER, DOOR SWITCH ドア スイッチ ホルダ	
2	FB4 - 1433 - 000		1	PLATE, DOOR SWITCH ドア スイッチ板	
3	FB4 - 1436 - 000		1	LEVER, ABSORPTION 吸収レバー	
4	FB4 - 1557 - 020		1	SPRING, TORSION ネジリ バネ	
5	FF5 - 7884 - 000		1	LEVER, CRANK クランク レバー	
6	FG6 - 1817 - 000		1	CABLE, FRONT DOOR SWITCH, DC 前ドア スイッチ束線 (DC)	J21,111,112
7	FH7 - 6253 - 000		1	SWITCH, DOOR ドア スイッチ	SW2
8	FS5 - 2928 - 000		1	SPRING, TENSION ヒツパリ バネ	
9	VS1 - 5057 - 002		1	CONNECTOR, SNAP TIGHT チュウケイ コネクタ	SEE NOTE J111
10	WC4 - 0153 - 000		1	MICRO SWITCH マイクロ スイッチ	MSW7 J112
11	XZ9 - 0251 - 000		1	CATCH, MAGNET マグネット キャッチ	
501	XB1 - 2230 - 809		1	SCREW,MACH.,TRUSS HEAD,M2.3X8 バインド ネジ	
502	XB3 - 6300 - 800		2	SCREW,RS,M3X8 RS タイト ネジ	
503	XD2 - 1100 - 642		1	RING,E E リング	

FIGURE 130 CONTROL PANEL ASSEMBLY 操作部

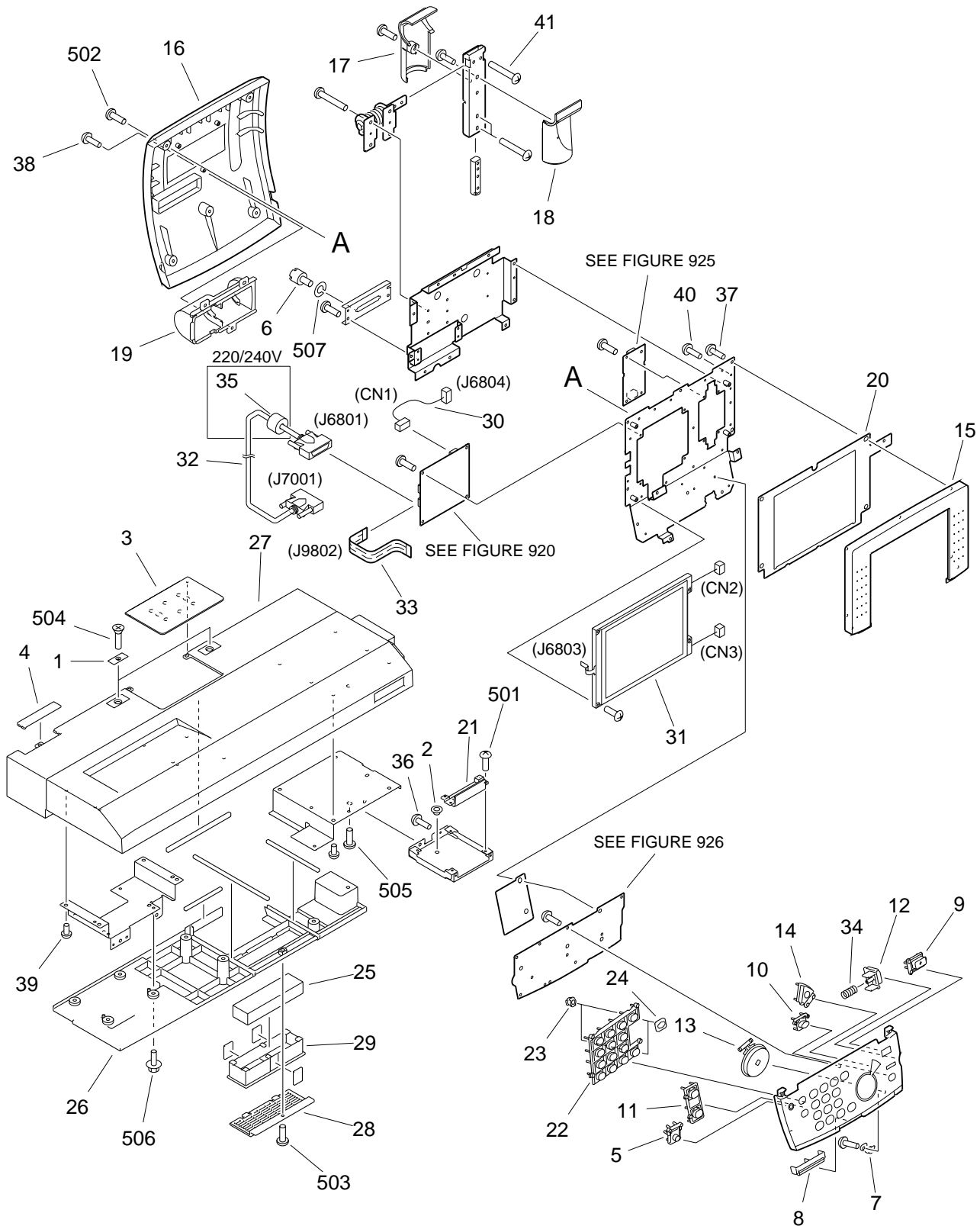

NOTE1: This assembly includes the assemblies shown in Figure 920, 925 and 926.

NOTE: This assembly does not include the parts shown with key No. 2, 3, 4, 21, 25, 26, 27, 28, 29, 32, 36, 39, 501, 503, 504, 505 and 506.

注1: このユニットはFigure 920, 925, 926のユニットを含みます。

注: このユニットにKey No. 2, 3, 4, 21, 25, 26, 27, 28, 29, 32, 36, 39, 501, 503, 504, 505, 506の部品は含まれません。

FIGURE & KEY NO.	PART NUMBER	RANK	QTY	DESCRIPTION	SERIAL NUMBER / REMARKS
130 -	FG6 - 8025 - 000		1	CONTROL PANEL ASSEMBLY 操作部	JAPANESE SEE NOTE 1
	FG6 - 8026 - 000		1	CONTROL PANEL ASSEMBLY 操作部	ENGLISH SEE NOTE 1
	FG6 - 8027 - 000		1	CONTROL PANEL ASSEMBLY 操作部	ILLUSTRATION SEE NOTE 1
	1 FA3 - 9315 - 000		2	PLATE, COVER 穴ふさぎ	
	2 FA9 - 3684 - 000		1	CUP カップ	SEE NOTE 2
3	FB4 - 2333 - 000		1	COVER, CHANGE 交換カバー	SEE NOTE 2
4	FB4 - 2343 - 000		1	PANEL, SERVICE サービス パネル	SEE NOTE 2
5	FB4 - 5005 - 000		1	KEY TOP, COUNTER カウンタ キー	
6	FB5 - 2131 - 000		2	SCREW, M2.6X4.2 コネクタ ビス	
7	FB5 - 2164 - 000		1	COVER, POWER LAMP 電源ランプ カバー	
8	FB5 - 2165 - 000		1	COVER, INDICATOR LAMP タリールランプ カバー	
9	FB5 - 2168 - 000		1	KEY TOP, RESET リセット キー	
10	FB5 - 2169 - 000		1	KEY TOP, ENERGY SAVING 節電キー	
11	FB5 - 2170 - 000		1	KEY TOP, MODE モード キー	
12	FB5 - 2171 - 000		1	KEY TOP, POWER 電源キー	
13	FB5 - 2172 - 000		1	KEY TOP, COPY コピー キー	
14	FB5 - 2173 - 000		1	KEY TOP, STOP ストップ キー	
15	FB5 - 2176 - 000		1	PANEL, FRONT 前カバー	
16	FB5 - 2177 - 000		1	PANEL, REAR 後カバー	
17	FB5 - 2178 - 000		1	PANEL, ARM, REAR アーム カバー(後)	
18	FB5 - 2179 - 000		1	PANEL, ARM, FRONT アーム カバー(前)	
19	FB5 - 2180 - 000		1	COVER, LOCK HINGE ロック ヒンジ カバー	
20	FB6 - 0454 - 000		1	SHEET, LCD ELECTROSTATIC LCD静電シート	
21	FB6 - 0598 - 000		1	COVER, INLET 入口カバー	SEE NOTE 2
22	FB6 - 0605 - 000		1	KEY TOP, NUMBERS テン キー	
23	FB6 - 0606 - 000		2	SPACER, KEY キー スペーサ	
24	FB6 - 0610 - 000		2	SPACER, KEY, UPPER キー スペーサ(上)	
25	FB6 - 0617 - 000		1	FILTER, AIR エア フィルタ	SEE NOTE 2
26	FF6 - 1498 - 000		1	PANEL, FRONT UPPER, LOWER 前上カバー(下)	SEE NOTE 2
27	FF6 - 1499 - 000		1	PANEL, FRONT UPPER 前上カバー	SEE NOTE 2

FIGURE & KEY NO.	PART NUMBER	RANK	QTY	DESCRIPTION	SERIAL NUMBER / REMARKS
130 - 28	FF6 - 1530 - 000		1	MOUNT, PRIMARY FILTER, 2 1次フィルタ台 (2)	SEE NOTE 2
29	FF6 - 1542 - 000		1	CASE, AIR FILTER, 2 エア フィルタ ケース (2)	SEE NOTE 2
30	FG3 - 2146 - 000		1	CABLE, INVERTER インバータ束線	CN1,6804
31	FG3 - 2147 - 000		1	LCD CONTROL PANEL UNIT 液晶パネル	J6803,CN2,3
32	FH2 - 6791 - 000		1	CABLE, CONTROL 操作部束線	SEE NOTE 2 J6801,7001
33	FH2 - 6842 - 000		1	CABLE, FLAT フラット ケーブル	J9802
34	FS6 - 2098 - 000		1	SPRING, COMPRESSION アッシュク バネ	
35	WE8 - 5951 - 000		1	CORE, FERRITE フェライト コア	220/240V
36	XA9 - 0266 - 000		1	SCREW,W/WASHER,M4X8 キクザツキ バインド ネジ	SEE NOTE 2
37	XA9 - 0591 - 000		26	SCREW,M3X8 タイト ネジ	
38	XA9 - 0596 - 000		3	SCREW,P,M3X6 P タイト ネジ	
39	XA9 - 0615 - 000		10	SCREW,M4X8 タイト ネジ	SEE NOTE 2
40	XA9 - 0670 - 000		1	SCREW,M3X6 セムス ネジ	
41	XA9 - 0940 - 000		8	SCREW,W/WASHER,M4X12 パネツキ バインド ネジ	
501	XB1 - 2300 - 605		6	SCREW,MACH.,TRUSS HEAD,M3X6 バインド ネジ	SEE NOTE 2
502	XB1 - 2300 - 607		29	SCREW,MACH.,TRUSS HEAD,M3X6 バインド ネジ	
503	XB1 - 2400 - 806		1	SCREW,MACH.,TRUSS HEAD,M4X8 バインド ネジ	SEE NOTE 2
504	XB1 - 3400 - 606		2	SCREW,MACH.,C.S.HEAD,M4X6 サラ ネジ	SEE NOTE 2
505	XB2 - 7400 - 606		1	SCREW,W/WASHER,M4X6 パネツキ バインド ネジ	SEE NOTE 2
506	XB3 - 6401 - 000		6	SCREW,RS,M4X10 RS タイト ネジ	SEE NOTE 2
507	XD1 - 3100 - 307		2	WASHER, SPRING バネ ザガネ	

FIGURE 190 SEPARATION FIXING FAN ASSEMBLY
 分離定着ファン部

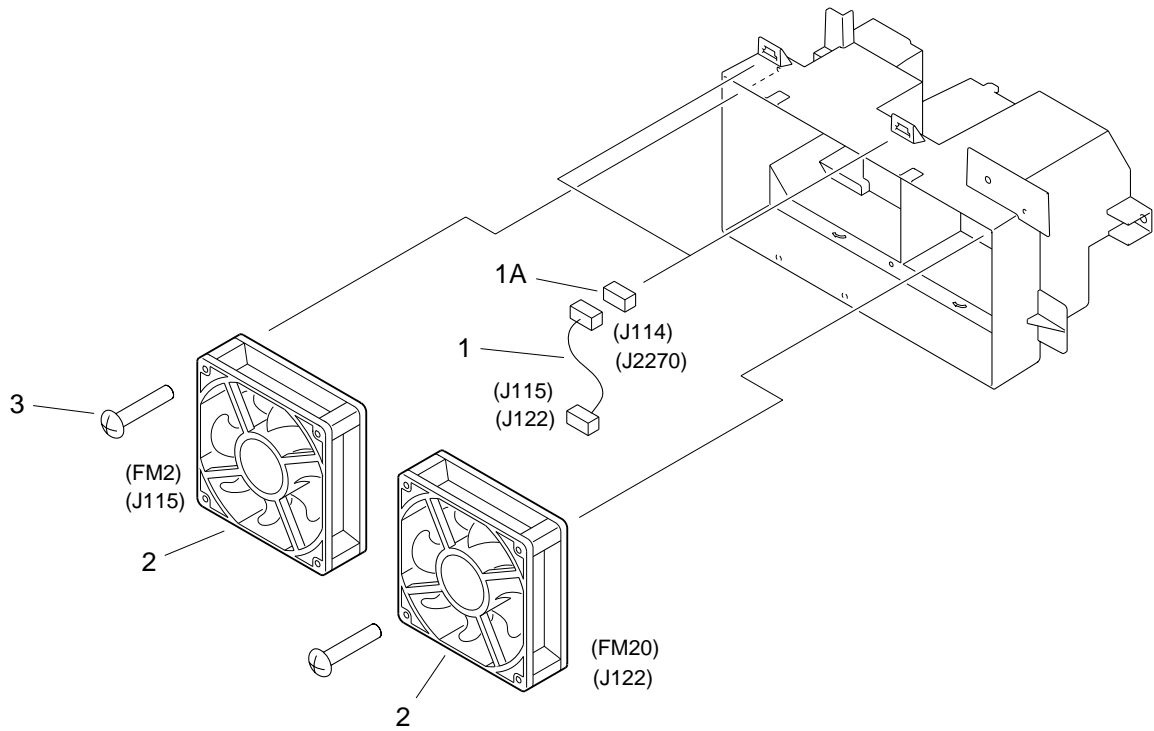

FIGURE & KEY NO.	PART NUMBER	RANK	QTY	DESCRIPTION	SERIAL NUMBER / REMARKS
190 -	FG6 - 8576 - 000		1	SEPARATION FIXING FAN ASS'Y 分離定着ファン部	
1	FG6 - 1898 - 000		2	CABLE, EXHAUST FAN CONNECTING 定着排熱ファン中継束線	J114,115 J122,2270
1A	VS1 - 5057 - 003		2	CONNECTOR, SNAP TIGHT チュウケイ コネクタ	J114,2270
2	FH6 - 1545 - 000		2	FAN, COOLING 冷却ファン	FM2,20 J115,122
3	XA9 - 0189 - 000		4	SCREW,M4X50 タッピン ネジ	

FIGURE 194 PRIMARY POLYGON LASER FAN ASSEMBLY 一次ポリゴンレーザファン部

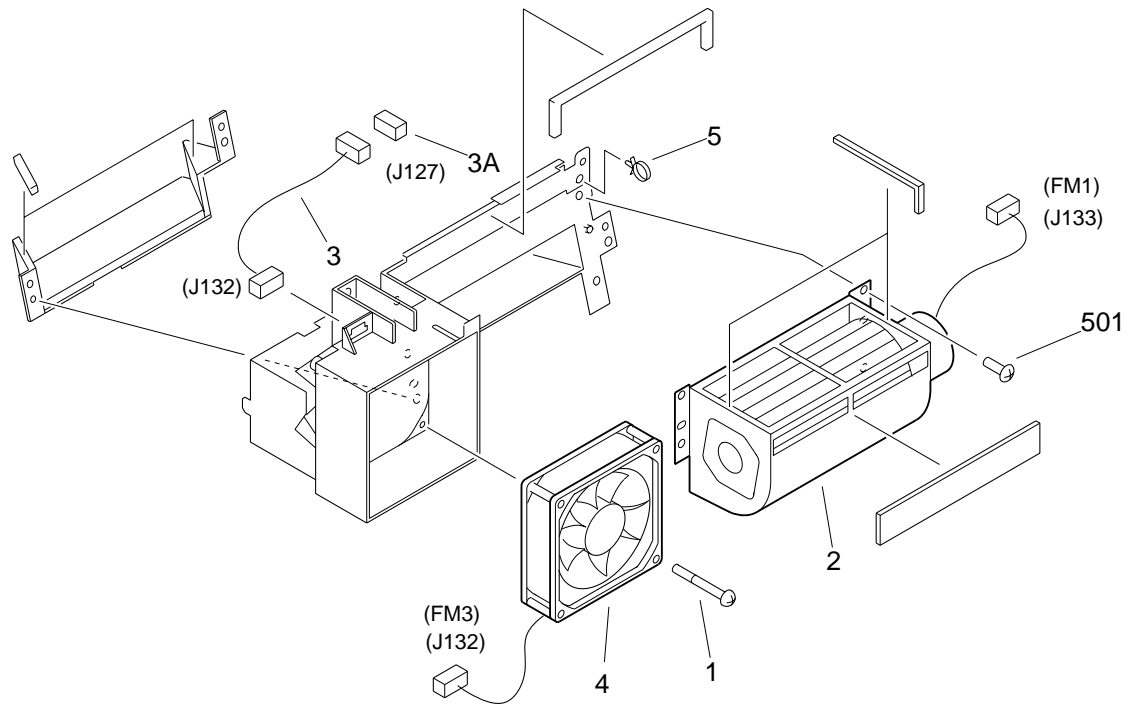

FIGURE & KEY NO.	PART NUMBER	RANK	QTY	DESCRIPTION	SERIAL NUMBER / REMARKS
194 -	FG6 - 7999 - 000		1	PRI. POLYGON LASER FAN ASS'Y 一次ポリゴン レーザ ファン部	
1	FC1 - 6853 - 000		2	SCREW, M4X35 タイト ネジ	
2	FF6 - 1502 - 000		1	FAN, PRIMARY POLYGON 1次ポリゴン ファン	FM1 J133
3	FG6 - 8622 - 000		1	CABLE, PRI. CORONA FAN CONNECT 一次帯電ファン中継束線	J127,132
3A	VS1 - 5057 - 003		1	CONNECTOR, SNAP TIGHT チュウケイ コネクタ	J127
4	FH6 - 1546 - 000		1	FAN, COOLING 冷却ファン	FM3 J132
5	WT2 - 5565 - 000		1	CLAMP, CABLE ソクセン オサエ	
501	XB4 - 5400 - 805		6	SCREW,P,M4X8 P タイト ネジ	

FIGURE 195 DRUM INTAKE FAN ASSEMBLY

ドラム吸引ファン部

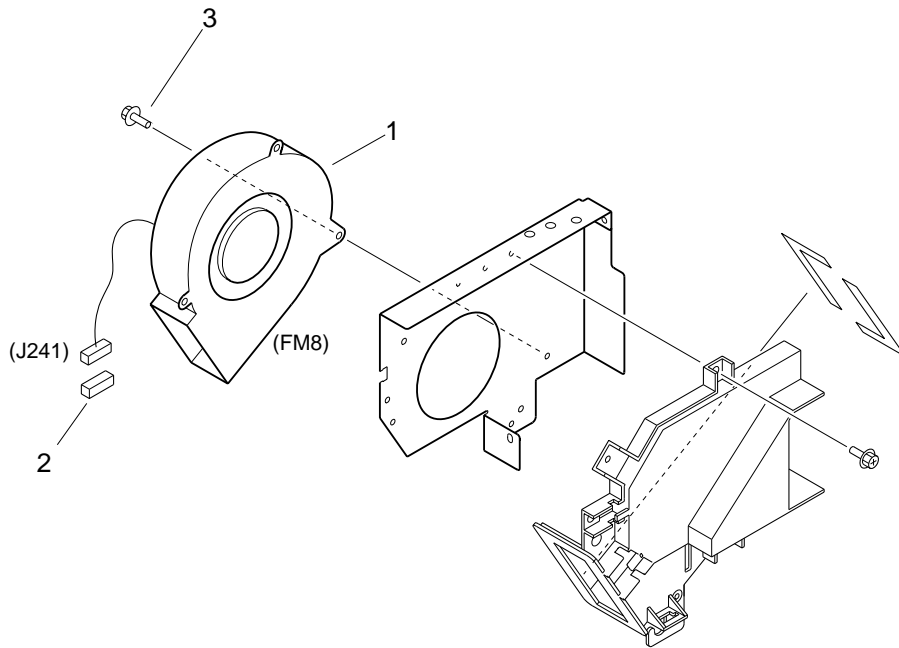

FIGURE & KEY NO.	PART NUMBER	RANK	QTY	DESCRIPTION	SERIAL NUMBER / REMARKS
195 -	FG6 - 1987 - 000		1	DRUM INTAKE FAN ASSEMBLY ドラム吸引ファン部	
1	FH6 - 1550 - 000		1	FAN, INTAKE 吸引ファン	FM8 J241
2	VS1 - 5057 - 003		1	CONNECTOR, SNAP TIGHT チュウケイ コネクタ	J241
3	XA9 - 0628 - 000		6	SCREW,RS,M4X8 RS タイト ネジ	

FIGURE 210 LENS MOUNT ASSEMBLY(1/2)

レンズ台部(1/2)

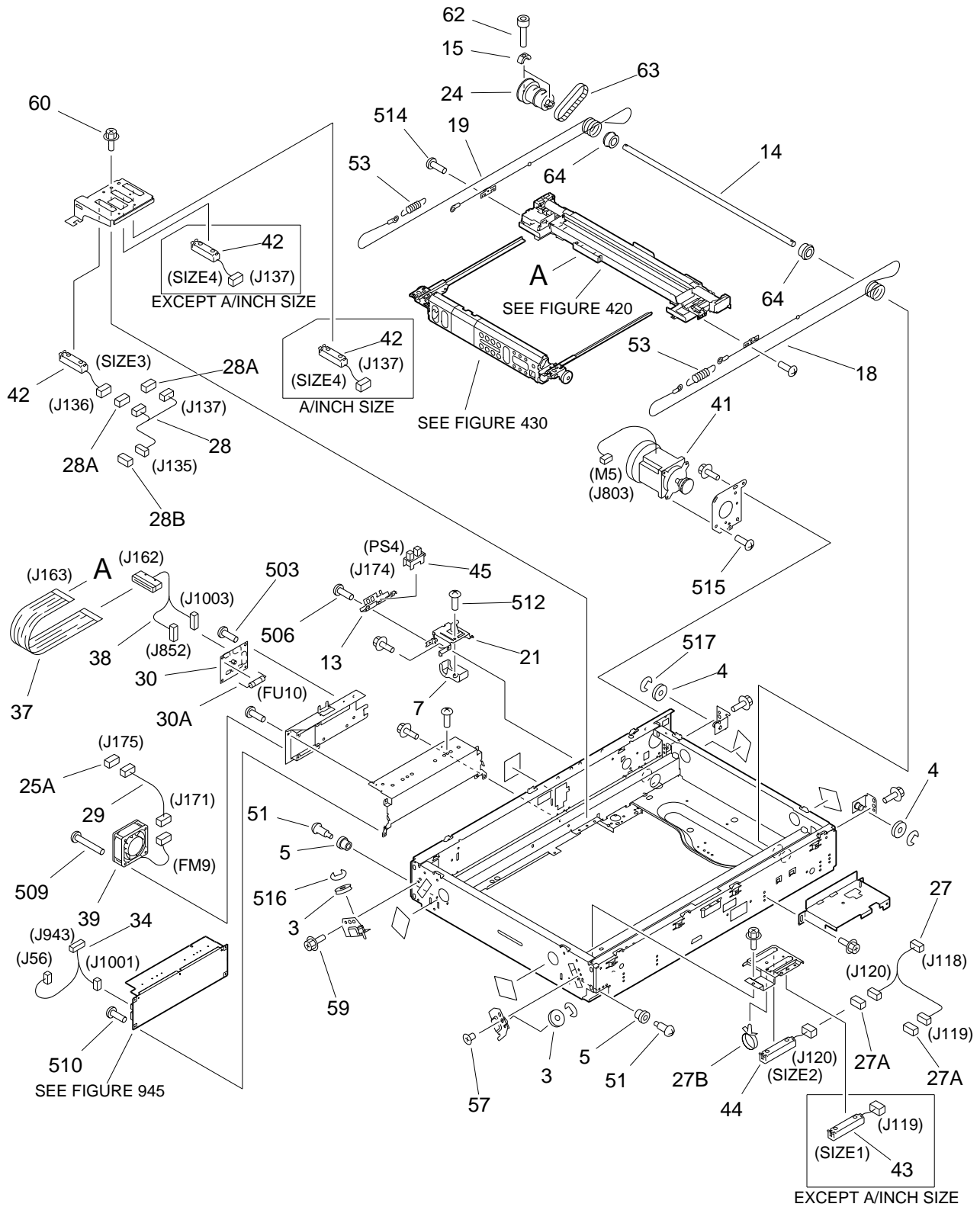

FIGURE 210 LENS MOUNT ASSEMBLY(2/2)

レンズ台部(2/2)

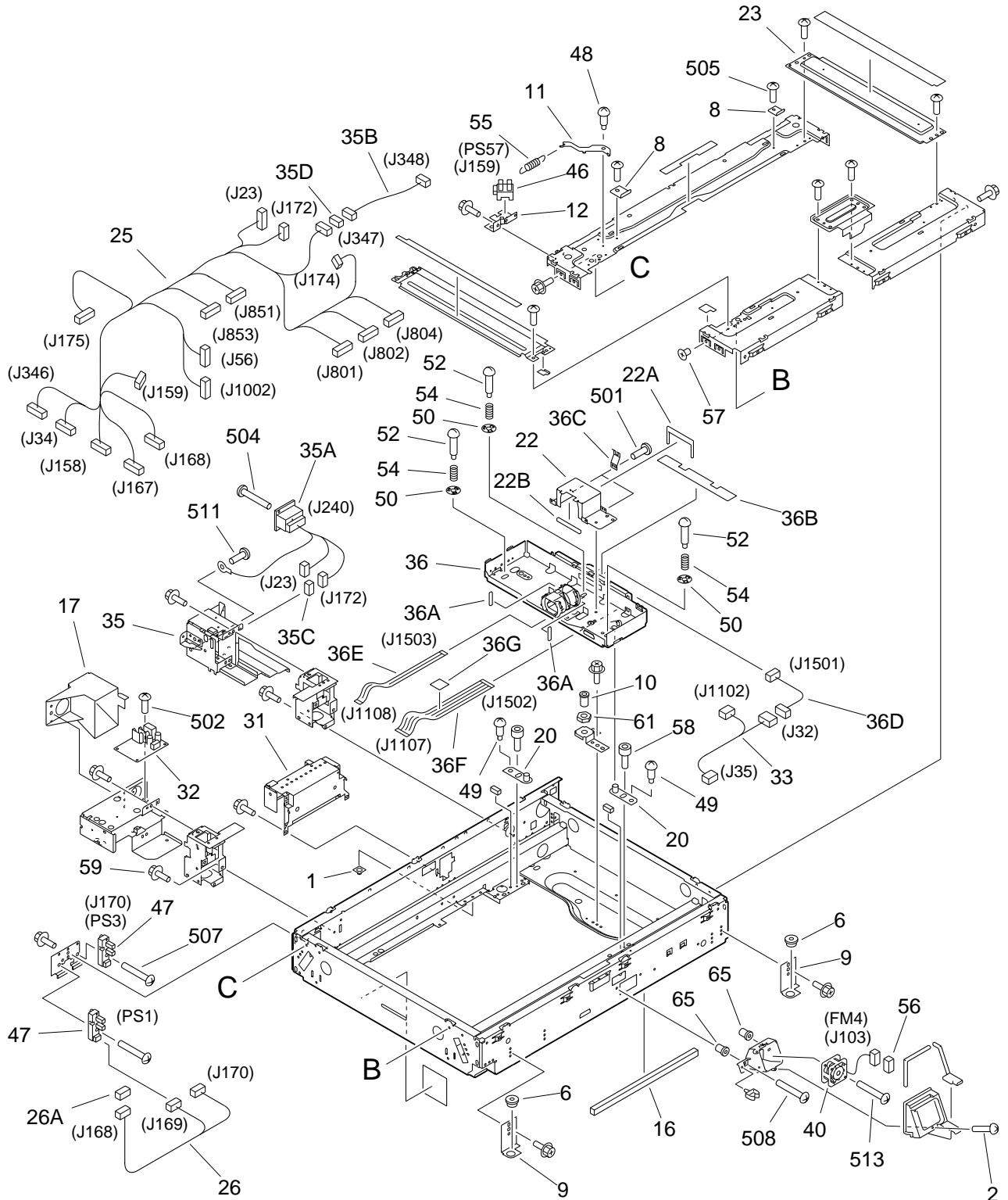

FIGURE & KEY NO.	PART NUMBER	RANK	QTY	DESCRIPTION	SERIAL NUMBER / REMARKS
210 -	NPN		RF	LENS MOUNT ASSEMBLY レンズ台部	
1	FA9 - 1800 - 000		1	CUP カップ	
2	FA9 - 2469 - 000		2	SCREW,M3X10 タイト ネジ	
3	FB1 - 7109 - 000		2	PULLEY プーリ	
4	FB1 - 7109 - 000		2	PULLEY プーリ	
5	FB1 - 7112 - 000		2	ROLLER, WIRE ワイヤ コロ	
6	FB2 - 6310 - 000		2	BUSHING, RUBBER ゴム ブッシュ	
7	FB2 - 8167 - 000		1	COVER, SENSOR センサ カバ-	
8	FB4 - 0715 - 000		2	PLATE, GLASS RETAINING ガラス押し板	
9	FB4 - 1428 - 000		2	PLATE, FIXING 固定板	
10	FB4 - 1734 - 000		1	SCREW, ADJUSTING 調整ネジ	
11	FB4 - 2358 - 000		1	LEVER, GLASS SENSOR ガラス検知レバー	
12	FB4 - 2360 - 000		1	HOLDER, SENSOR センサ ホルダ	
13	FB4 - 2366 - 000		1	HOLDER, SENSOR センサ ホルダ	
14	FB4 - 2376 - 000		1	SHAFT, SCANNER DRIVE 光学駆動軸	
15	FB4 - 2384 - 000		2	LOCK, PULLEY プーリ ロック	
16	FB5 - 7054 - 000		1	SEAL, DUST-PROOF, FRONT 防塵シール (前)	
17	FB6 - 0591 - 000		1	DUCT, INVERTER COOLING インバータ冷却ダクト	
18	FB6 - 2724 - 000		1	WIRE, SCANNER, FRONT 光学ワイヤ (前)	
19	FB6 - 2725 - 000		1	WIRE, SCANNER, REAR 光学ワイヤ (後)	
20	FF5 - 2173 - 000		2	PLATE, POSITIONING 位置決め板	
21	FF5 - 7883 - 000		1	PLATE, SENSOR ARM SUPPORT 検知アーム支板	
22	FF5 - 7938 - 000		1	COVER, CCD CCDカバー	
22A	FB4 - 1712 - 000		1	SEAL, CCD COVER, CCD CCDカバー シール (CCD)	
22B	FB4 - 1714 - 000		1	SEAL, CCD COVER, UPPER CCDカバー シール (上)	
23	FF5 - 8892 - 000	N	1	UPPER CROSSMEMBER, RIGHT 上ステイ (右)	
24	FF9 - 1909 - 000		1	PULLEY, DRIVE 駆動プーリ	
25	FG6 - 1823 - 000		1	CABLE, REAR UPPER 後上束線	J23,34,56,158,159 J167,168,172,174,175 J346,347,801,802 J804,851,853,1002
25A	VS1 - 5057 - 003		1	CONNECTOR, SNAP TIGHT チュウケイ コネクタ	J175

FIGURE & KEY NO.	PART NUMBER	RANK	QTY	DESCRIPTION	SERIAL NUMBER / REMARKS
210 - 26	FG6 - 1824 - 000		1	CABLE, HOME POSITION SENSOR ホーム センサ束線	J168-170
26 A	VS1 - 5057 - 006		1	CONNECTOR, SNAP TIGHT チュウケイ コネクタ	J168
27	FG6 - 1827 - 000		1	CABLE, SIZE SENSOR 1/2 原稿サイズ検知 (1/2) 束線	J118-120
27 A	VS1 - 5057 - 003		2	CONNECTOR, SNAP TIGHT チュウケイ コネクタ	J119,120
27 B	WT2 - 5178 - 000		1	CLIP, CABLE ロッキング ワイヤ サドル	
28	FG6 - 1828 - 000		1	CABLE, SIZE SENSOR 3/4 原稿サイズ検知 (3/4) 束線	J135-137
28 A	VS1 - 5057 - 003		2	CONNECTOR, SNAP TIGHT チュウケイ コネクタ	J136,137
28 B	VS1 - 6318 - 006		1	CONNECTOR, SNAP TIGHT チュウケイ コネクタ	J135
29	FG6 - 1893 - 000		1	CABLE, INVERTER FAN CONNECTING インバータ ファン中継束線	J171,175
30	FG6 - 1942 - 000		1	EXPOSURE CONTROL PCB ASSEMBLY 調光制御回路基板	
30 A	VD7 - 1622 - 001		1	FUSE, 2A, 60V ヒューズ	FU10
31	FG6 - 2033 - 000		1	SCANNER MOTOR DRIVER PCB ASS'Y 光学モータ ドライバ回路基板	
32	FG6 - 2512 - 000		1	TRANSFORMER PCB ASSEMBLY 高圧回路基板	
33	FG6 - 7213 - 000		1	CABLE, CCD POWER CONNECTING CCD電源中継束線	J32,35,1102
34	FG6 - 7260 - 000		1	CABLE, INV. POWER CONNECTING インバータ電源中継束線	J56,943,1001
35	FG6 - 7332 - 000		1	DF CONNECTOR MOUNT UNIT DFコネクタ台ユニット	
35 A	FG6 - 6902 - 000		1	CABLE, LATTICE, RF ラティス束線 (RF)	J23,172,240
35 B	FG6 - 7223 - 000		1	CABLE, OPT. MOTOR CONNECTING 光学モータ中継束線	J347,348
35 C	VS1 - 5057 - 007		1	CONNECTOR, SNAP TIGHT チュウケイ コネクタ	J172
35 D	VS1 - 6318 - 003		1	CONNECTOR, SNAP TIGHT チュウケイ コネクタ	J347
36	FG6 - 7401 - 000		1	CCD UNIT CCDユニット	
36 A	FB4 - 1713 - 000		2	SEAL, CCD COVER, SIDE CCDカバー シール (サイド)	
36 B	FB4 - 1715 - 000		1	SHEET, LIGHT-BLOCKING 遮光シート	
36 C	FB4 - 1740 - 000		2	SPRING, LEAF イタ パネ	
36 D	FG6 - 1822 - 000		1	CABLE, CCD CONNECTING CCD中継束線	J32,1501
36 E	FH2 - 6898 - 000		1	CABLE, FLAT フラット ケーブル	J1108,1503
36 F	FH2 - 6899 - 000		1	CABLE, FLAT フラット ケーブル	J1107,1502
36 G	FS7 - 8109 - 000		1	LABEL, CABLE CONNECTOR ケーブル コネクタ ラベル	
37	FH2 - 6452 - 000		1	CABLE, FLUORESCENT LAMP 蛍光灯フレキ束線	J162,163
38	FH2 - 6574 - 000		1	CABLE, FLUORESCENT 蛍光灯束線	J162,852,1003

FIGURE & KEY NO.	PART NUMBER	RANK	QTY	DESCRIPTION	SERIAL NUMBER / REMARKS
210 - 39	FH6 - 1544 - 000		1	FAN, COOLING 冷却ファン	FM9 J171
40	FH6 - 1547 - 000		1	FAN, COOLING 冷却ファン	FM4 J103
41	FH6 - 1886 - 000		1	MOTOR, STEPPING ステッピング モータ	M5 J803
42	FH7 - 7423 - 000		2	SENSOR, DOCUMENT, REAR 原稿検知センサ (後)	SIZE3,4 J136,137
43	FH7 - 7424 - 000		1	SENSOR, DOCUMENT, FRONT 原稿検知センサ (前)	EXCEPT A/INCH SIZE SIZE1 J119
44	FH7 - 7424 - 000		1	SENSOR, DOCUMENT, FRONT 原稿検知センサ (前)	SIZE2 J120
45	FH7 - 7462 - 000		1	PHOTO-INTERRUPTER フォトインタラプタ	PS4 J174
46	FH7 - 7462 - 000		1	PHOTO-INTERRUPTER フォトインタラプタ	PS57 J159
47	FH7 - 7485 - 000		2	PHOTO-INTERRUPTER フォトインタラプタ	PS1,3 J169,170
48	FS1 - 9002 - 000		1	SCREW, STEPPED, M4 段ビス	
49	FS2 - 9267 - 000		1	SCREW, STEPPED, M4 ダンビス	
50	FS5 - 6684 - 000		3	PLATE, CCD SPRING CCDバネ受け	
51	FS5 - 9219 - 000		2	SCREW, STEPPED, M4 段ビス	
52	FS5 - 9491 - 000		3	SCREW, STEPPED, M4 段ビス	
53	FS6 - 2737 - 000		2	SPRING, TENSION ヒツパリ バネ	
54	FS6 - 2761 - 000		3	SPRING, COMPRESSION アッシュク バネ	
55	FS6 - 2894 - 000		1	SPRING, TENSION ヒツパリ バネ	
56	VS1 - 5057 - 003		1	CONNECTOR, SNAP TIGHT チュウケイ コネクタ	J103
57	XA9 - 0271 - 000		6	SCREW, M4X6 ネジ	
58	XA9 - 0520 - 000		2	BOLT, HEX SKT, M4X8 六角穴付ボルト ダブルセムス (M4x8)	
59	XA9 - 0628 - 000		34	SCREW, RS, M4X8 RS タイト ネジ	
60	XA9 - 0643 - 000	AR		SCREW, RS, M4X10 RS タイト ネジ	
61	XA9 - 0965 - 000		1	NUT, HEX, M10X5 ロツカク ナット	
62	XA9 - 1092 - 000		2	SCREW, ALLEN HEAD, M4X20 ロツカク アナツキ ボルト	
63	XF9 - 0680 - 000		1	BELT, DRIVE 駆動ベルト	
64	XG9 - 0018 - 000		2	BEARING, BALL, 6000ZZNRC3 ボール ベアリング	
65	XH9 - 0006 - 000		2	BUSHING, RUBBER, (WITH M4 NUT) クワイタイト	
501	XB1 - 2300 - 409		2	SCREW, MACH., TRUSS HEAD, M3X4 バインド ネジ	
502	XB1 - 2300 - 607		4	SCREW, MACH., TRUSS HEAD, M3X6 バインド ネジ	
503	XB1 - 2300 - 609		4	SCREW, MACH., TRUSS HEAD, M3X6 バインド ネジ	

FIGURE & KEY NO.	PART NUMBER	R A N K	Q' T Y	DESCRIPTION	SERIAL NUMBER / REMARKS
210 - 504	XB1 - 2301 - 207		2	SCREW,MACH.,TRUSS HEAD,M3X12 バインド ネジ	
505	XB1 - 2400 - 609		2	SCREW,MACH.,TRUSS HEAD,M4X6 バインド ネジ	
506	XB1 - 2400 - 609		6	SCREW,MACH.,TRUSS HEAD,M4X6 バインド ネジ	
507	XB1 - 2401 - 209		2	SCREW,MACH.,TRUSS HEAD,M4X12 バインド ネジ	
508	XB1 - 2401 - 409		2	SCREW,MACH.,TRUSS HEAD,M4X14 バインド ネジ	
509	XB1 - 2403 - 009		2	SCREW,MACH.,TRUSS HEAD,M4X30 バインド ネジ	
510	XB2 - 4300 - 607		6	SCREW,W/WASHER,M3X6 パネツキ ナベ ネジ	
511	XB2 - 7400 - 607		1	SCREW,W/WASHER,M4X6 パネツキ バインド ネジ	
512	XB4 - 7300 - 809		1	SCREW,TAPPING,TRUSS HEAD,M3X8 バインド タッピン ネジ	
513	XB4 - 7303 - 009		2	SCREW,TAPPING,TRUSS HEAD,M3X30 バインド タッピン ネジ	
514	XB6 - 7300 - 609		4	SCREW,TP,M3X6 TP ネジ	
515	XB6 - 7400 - 609		2	SCREW,TP,M4X6 TP ネジ	
516	XD2 - 1100 - 642		2	RING,E E リング	
517	XD2 - 1100 - 642		2	RING,E E リング	

FIGURE 215 SCANNER MOUNT ASSEMBLY
 スキャナ台部

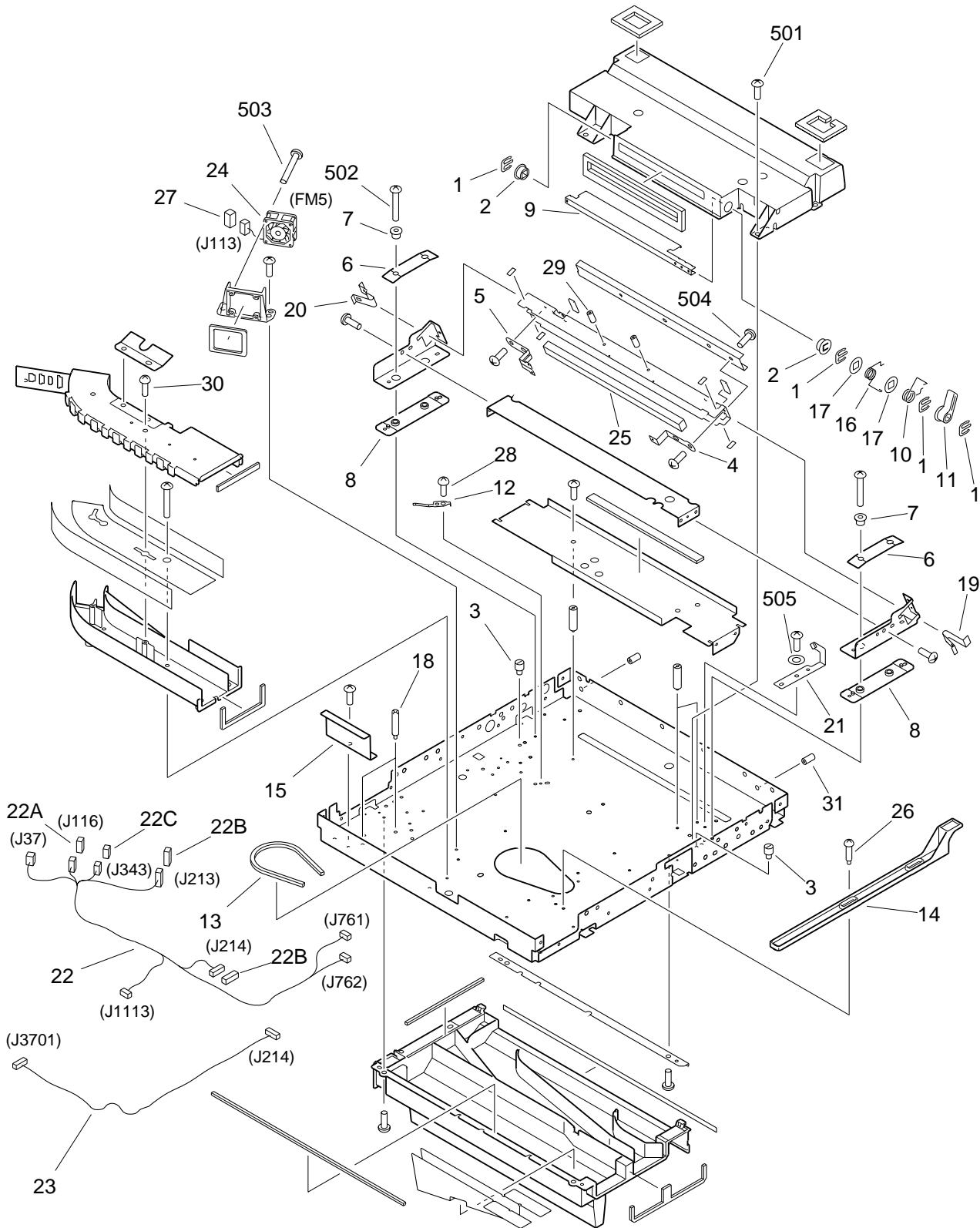
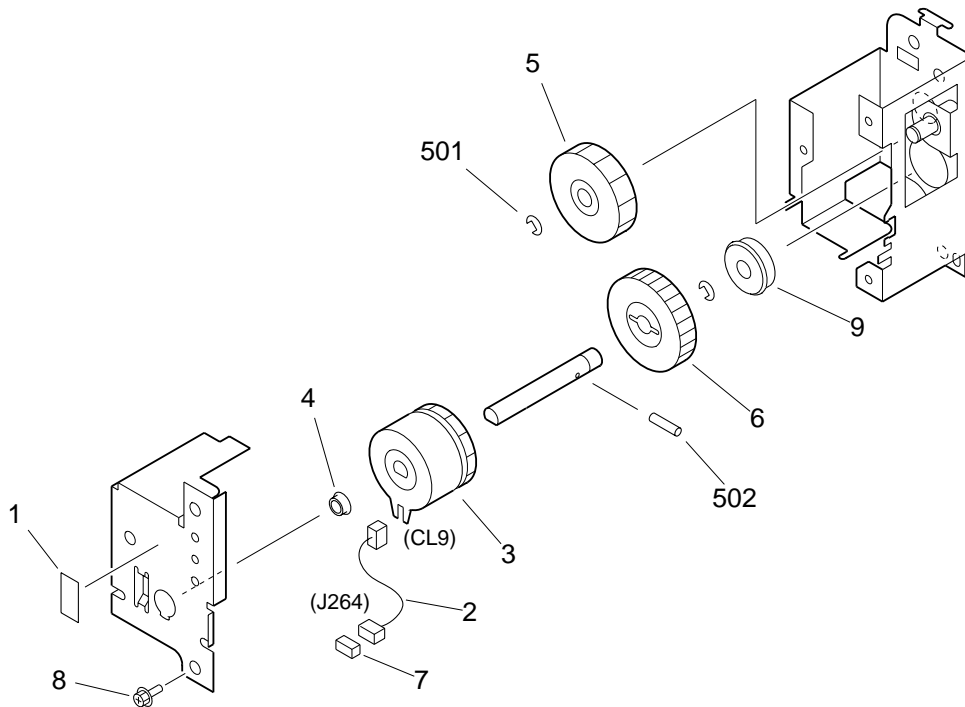

FIGURE & KEY NO.	PART NUMBER	RANK	QTY	DESCRIPTION	SERIAL NUMBER / REMARKS
215 -	NPN		RF	SCANNER MOUNT ASSEMBLY スキャナ台部	
1	FA2 - 8361 - 000		4	RETAINER キンテイ	
2	FB2 - 1382 - 000		2	COLLAR カラ	
3	FB4 - 1512 - 000		2	PIN, MIRROR SUPPORT ミラー支板ピン	
4	FB4 - 1521 - 000		1	SPRING, LEAF, FRONT 板バネ (前)	
5	FB4 - 1522 - 000		1	SPRING, LEAF, REAR 板バネ (後)	
6	FB4 - 1532 - 000		2	SPRING, LEAF 板バネ	
7	FB4 - 1533 - 000		4	SPACER スペーサ	
8	FB4 - 1534 - 000		2	PLATE, SUPPORT 支板プレート	
9	FB4 - 1538 - 000		1	PLATE, SHUTTER シャッター板	
10	FB4 - 1539 - 020		1	SPRING, TORSION ネジリ バネ	
11	FB4 - 1540 - 000		1	ARM, SHUTTER シャッター アーム	
12	FB4 - 1546 - 000		1	PLATE, GROUNDING アース板	
13	FB4 - 1550 - 000		1	CUSHION, RUBBER クッション ゴム	
14	FB4 - 1554 - 000		1	PLATE, SHUTTER SLIDE シャッター スライド板	
15	FB4 - 1564 - 000		1	COVER, IMAGE PROCESSOR CABLE イメージ プロセッサ束線カバー	
16	FB5 - 4346 - 000		1	SPRING, TORSION ネジリ バネ	
17	FB5 - 4347 - 000		2	WASHER, SHUTTER シャッター ワッシャ	
18	FB5 - 7042 - 000		2	SPACER, CABLE SUPPORT ケーブル サポート スペーサ	
19	FB5 - 8809 - 000		1	SPRING, LEAF, FRONT 板バネ (前)	
20	FB5 - 8810 - 000		1	SPRING, LEAF, REAR 板バネ (後)	
21	FF5 - 7717 - 000		1	MIRROR, BEAM DETECTOR ビーム デテクタ ミラー	
22	FG6 - 1826 - 000		1	CABLE, LENS MOUNT INTERNAL レンズ台内部中継束線	J37,116,213,214,343 J761,762,1113
22 A	VS1 - 5057 - 004		1	CONNECTOR, SNAP TIGHT チュウケイ コネクタ	J116
22 B	VS1 - 5057 - 006		2	CONNECTOR, SNAP TIGHT チュウケイ コネクタ	J213,214
22 C	VS1 - 6318 - 004		1	CONNECTOR, SNAP TIGHT チュウケイ コネクタ	J343
23	FG6 - 7202 - 000		1	CABLE, BEAM DETECT ビーム デテクタ束線	J214,3701
24	FH6 - 1547 - 000		1	FAN, COOLING 冷却ファン	FM5 J113
25	FN5 - 4009 - 000		1	MIRROR, DIGITAL デジタル ミラー	
26	FS2 - 9001 - 000		2	SCREW, STEPPED, M4 ダン ビス	

FIGURE & KEY NO.	PART NUMBER	RANK	QTY	DESCRIPTION	SERIAL NUMBER / REMARKS
215 - 27	VS1 - 5057 - 003		1	CONNECTOR, SNAP TIGHT チュウケイ コネクタ	J113
28	XA9 - 0265 - 000		1	SCREW,W/WASHER,TRUSS HEAD ザツキ バインド ネジ	
29	XA9 - 0427 - 000		2	SETSCREW,M4X8 ロッカク アナツキ トメネジ	
30	XA9 - 0870 - 000		2	SCREW,M4X10 タイト ネジ	
31	XA9 - 1091 - 000		2	SETSCREW,M4X8 ロッカク アナツキ トメネジ	
501	XB1 - 2400 - 609		17	SCREW,MACH.,TRUSS HEAD,M4X6 バインド ネジ	
502	XB1 - 2401 - 409		6	SCREW,MACH.,TRUSS HEAD,M4X14 バインド ネジ	
503	XB4 - 7303 - 007		2	SCREW,TAPPING,TRUSS HEAD,M3X30 バインド タッピン ネジ	
504	XB6 - 7400 - 609		4	SCREW,TP,M4X6 TP ネジ	
505	XD1 - 1108 - 221		1	SHIM ヒョウジュン ワッシャ	

FIGURE 230 VERTICAL PATH DRIVE ASSEMBLY

縦パス駆動部



NOTE: This assembly does not include the part shown with key No.7.
 注: このユニットにKey No. 7の部品は含まれません。

FIGURE & KEY NO.	PART NUMBER	RANK	QTY	DESCRIPTION	SERIAL NUMBER / REMARKS
230 -	FG6 - 8577 - 000		1	VERTICAL PATH DRIVE ASSEMBLY 縦パス駆動部	
1	FA9 - 3822 - 000		1	LABEL, DISCRIMINATE 識別ラベル	
2	FG6 - 8623 - 000		1	CABLE, CLUTCH クラッチ束線	J264
3	FH6 - 5043 - 000		1	CLUTCH, ELECTROMAGNETIC 電磁クラッチ	CL9
4	FS1 - 1189 - 000		1	BUSHING ブッシング	
5	FS3 - 0165 - 000		1	GEAR, 40T 40T ギア	
6	FS5 - 0398 - 000		1	GEAR, 40T 40T ギア	
7	VS1 - 5057 - 002		1	CONNECTOR, SNAP TIGHT チュウケイ コネクタ	SEE NOTE J264
8	XA9 - 0628 - 000		3	SCREW, RS, M4X8 RS タイト ネジ	
9	XG9 - 0249 - 000		1	BEARING, BALL ボール ベアリング	
501	XD2 - 1100 - 642		2	RING, E E リング	
502	XD3 - 2200 - 162		1	PIN, DOWEL ヘイコウ ピン	

FIGURE 231 LIFTER DRIVE ASSEMBLY

リフタ駆動部

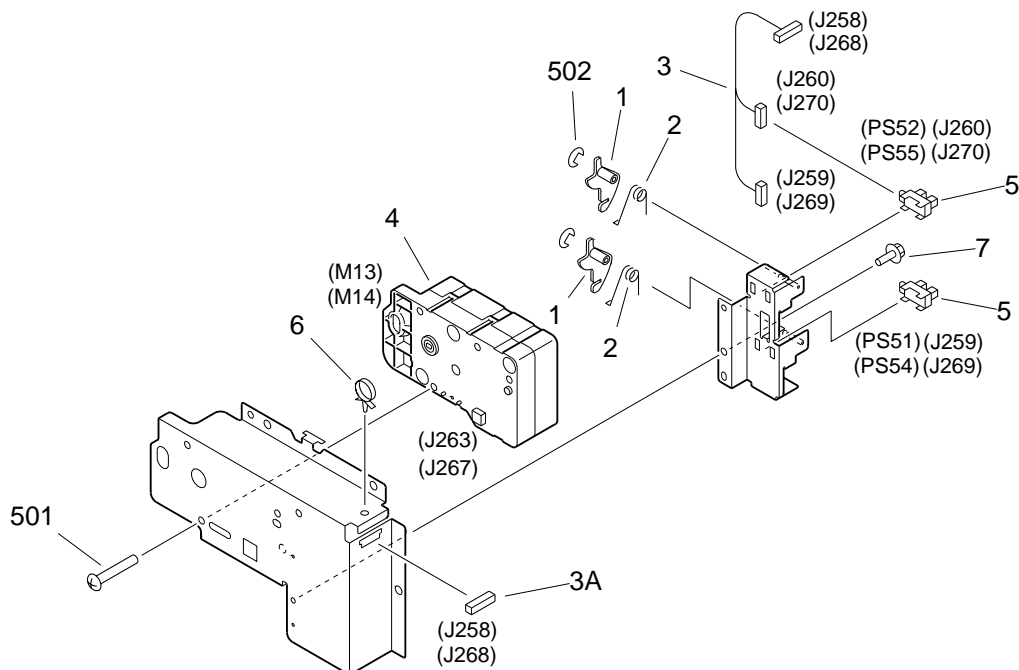

NOTE: This assembly does not include the part shown with key No.6.

注：このユニットにKey No. 6の部品は含まれません。

FIGURE & KEY NO.	PART NUMBER	RANK	QTY	DESCRIPTION	SERIAL NUMBER / REMARKS
231 -	FG6 - 2243 - 000		2	LIFTER DRIVE ASSEMBLY リフタ駆動部	
1	FB2 - 9248 - 000		2	ARM, PAPER SENSOR 紙検知アーム	
2	FB5 - 0553 - 000		2	SPRING, TORSION ネジリ バネ	
3	FG6 - 1888 - 000		1	CABLE, DECK SENSOR デッキ残量検知束線	J258-260 J268-270
3A	VS1 - 5057 - 006		1	CONNECTOR, SNAP TIGHT チュウケイ コネクタ	J258,268
4	FH6 - 1541 - 000		1	MOTOR, DC 19.2W DCモータ	M13,14 J263,267
5	FH7 - 7462 - 000		2	PHOTO-INTERRUPTER フォトインタラプタ	PS51,52,54,55 J259,260,269,270
6	WT2 - 5565 - 000		1	CLAMP, CABLE ソクセン オサエ	SEE NOTE
7	XA9 - 0628 - 000		1	SCREW,RS,M4X8 RS タイト ネジ	
501	XB5 - 6401 - 609		3	SCREW,CT,M4X16 CT ネジ	
502	XD2 - 1100 - 242		2	RING, E E リング	

FIGURE 250 MAIN DRIVE ASSEMBLY メイン駆動部

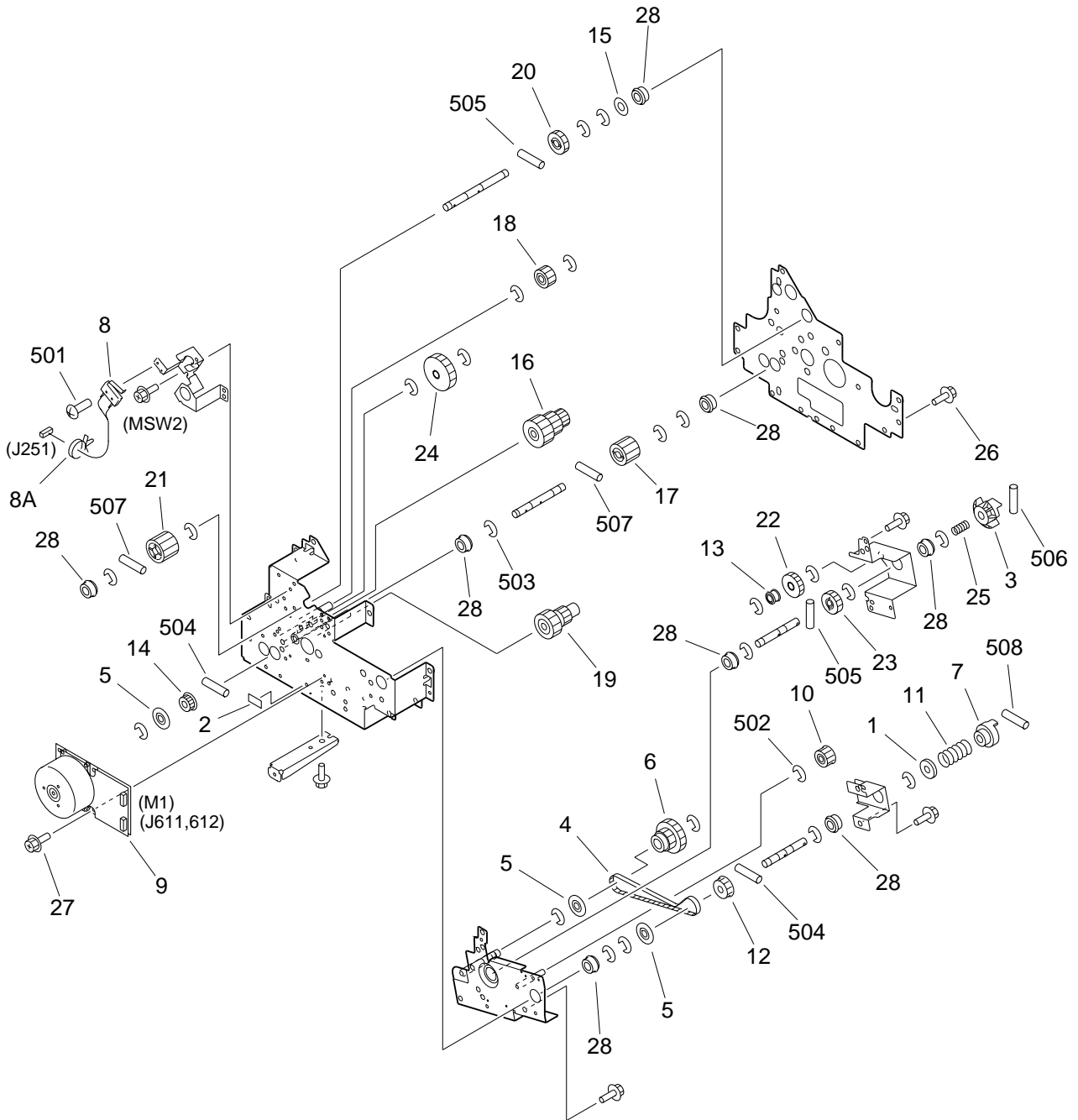

FIGURE & KEY NO.	PART NUMBER	R A N K	Q' T Y	DESCRIPTION	SERIAL NUMBER / REMARKS
250 -	FG6 - 8009 - 000		1	MAIN DRIVE ASSEMBLY メイン駆動部	
1	FA6 - 8304 - 000		1	WASHER, SPRING バネ ザガネ	
2	FA9 - 3822 - 000		1	LABEL, DISCRIMINATE 識別ラベル	
3	FB2 - 1047 - 000		1	COUPLING, INPUT 入力カップリング	
4	FB4 - 1766 - 000		1	BELT, TIMING タイミング ベルト	
5	FB4 - 1806 - 000		2	FLANGE フランジ	
6	FB5 - 6895 - 000		1	GEAR, 38T/36T/PULLY, 22T 38T/36T ギア/22T プーリ	
7	FB6 - 0581 - 000		1	COUPLING カップリング	
8	FG6 - 6903 - 000		1	CABLE, WASTE TONER SWITCH 廃トナー スイッチ束線	MSW2 J251
8A	WT2 - 5565 - 000		1	CLAMP, CABLE ソクセン オサエ	
9	FH6 - 1935 - 000		1	MOTOR, BRUSHLESS ブラシレス モータ	M1 J611,612
10	FS2 - 3495 - 000		1	PULLEY プーリ	
11	FS5 - 2978 - 000		1	SPRING, COMPRESSION アッシュク バネ	
12	FS5 - 3609 - 000		1	PULLEY, 22T 22T プーリ	
13	FS5 - 3612 - 000		1	PULLEY プーリ	
14	FS5 - 3890 - 000		1	PULLT, 18T 18T プーリ	
15	FS5 - 6487 - 000		1	SHIM ワッシャ	
16	FS7 - 0012 - 000		1	GEAR, 50T/24T/18T 50T/24T/18T ギア	
17	FS7 - 0014 - 000		1	GEAR, 24T 24T ギア	
18	FS7 - 0016 - 000		1	GEAR, 20T 20T ギア	
19	FS7 - 0017 - 000		1	GEAR, 18T/27T 18T/27T ギア	
20	FS7 - 0018 - 000		1	GEAR, 24T 24T ギア	
21	FS7 - 0019 - 000		1	GEAR, 26T 26T ギア	
22	FS7 - 0896 - 000		1	GEAR, 44T 44T ギア	
23	FS7 - 0897 - 000		1	GEAR, 40T 40T ギア	
24	FS7 - 0898 - 000		1	GEAR, 39T 39T ギア	
25	FS7 - 2531 - 000		1	SPRING, COMPRESSION アッシュク バネ	
26	XA9 - 0628 - 000		12	SCREW, RS, M4X8 RS タイト ネジ	
27	XA9 - 1030 - 000		4	SCREW, RS, M4X12 RS タイト ネジ	
28	XG9 - 0250 - 000		10	BEARING, BALL ボール ベアリング	

FIGURE & KEY NO.	PART NUMBER	R A N K	Q' T Y	DESCRIPTION	SERIAL NUMBER / REMARKS
250 - 501	XB1 - 2231 - 009		1	SCREW,MACH.,TRUSS HEAD,M2.3X10 バインド ネジ	
502	XD2 - 1100 - 502		1	RING,E E リング	
503	XD2 - 1100 - 642		18	RING,E E リング	
504	XD3 - 2200 - 122		2	PIN,DOWEL ヘイコウ ピン	
505	XD3 - 2200 - 142		2	PIN,DOWEL ヘイコウ ピン	
506	XD3 - 2200 - 162		2	PIN,DOWEL ヘイコウ ピン	
507	XD3 - 2200 - 182		2	PIN,DOWEL ヘイコウ ピン	
508	XD3 - 2300 - 142		1	PIN,DOWEL ヘイコウ ピン	

FIGURE 251 DRUM DRIVE ASSEMBLY

ドラム駆動部

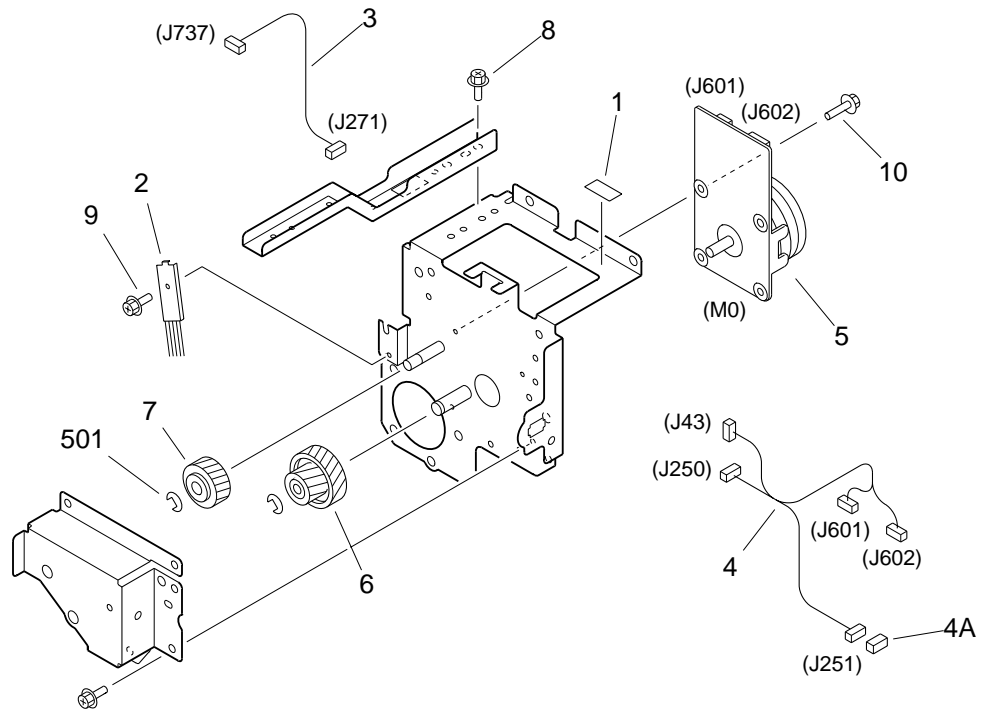

FIGURE & KEY NO.	PART NUMBER	RANK	QTY	DESCRIPTION	SERIAL NUMBER / REMARKS
251 -	FG6 - 8008 - 000		1	DRUM DRIVE ASSEMBLY ドラム駆動部	
1	FA9 - 3822 - 000		1	LABEL, DISCRIMINATE 識別ラベル	
2	FC1 - 1117 - 000		1	ELIMINATOR, STATIC CHARGE 除電針	
3	FG6 - 3570 - 000		1	CABLE, SEPARATION CLAW CONNECT 分離爪中継束線	J271,737
4	FG6 - 6885 - 000		1	CABLE, DRUM MOTOR DRIVE ドラムモータ駆動中継束線	J43,250,251,601,602
4A	VS1 - 5057 - 002		1	CONNECTOR, SNAP TIGHT チュウケイ コネクタ	J251
5	FH6 - 1934 - 000		1	MOTOR, BRUSHLESS ブラシレス モータ	M0 J601,602
6	FS7 - 0010 - 000		1	GEAR, 19T/63T 19T/63T ギア	
7	RS6 - 0057 - 000		1	GEAR, 49T 49T ギア	
8	XA9 - 0628 - 000		7	SCREW,RS,M4X8 RS タイト ネジ	
9	XA9 - 0813 - 000		1	SCREW,RS,M3X8 RS タイト ネジ	
10	XA9 - 0962 - 000		4	SCREW,RS,M3X10 RS タイト ネジ	
501	XD2 - 1100 - 642		2	RING,E E リング	

FIGURE 260 PAPER PICK-UP DRIVE ASSEMBLY
給紙駆動部

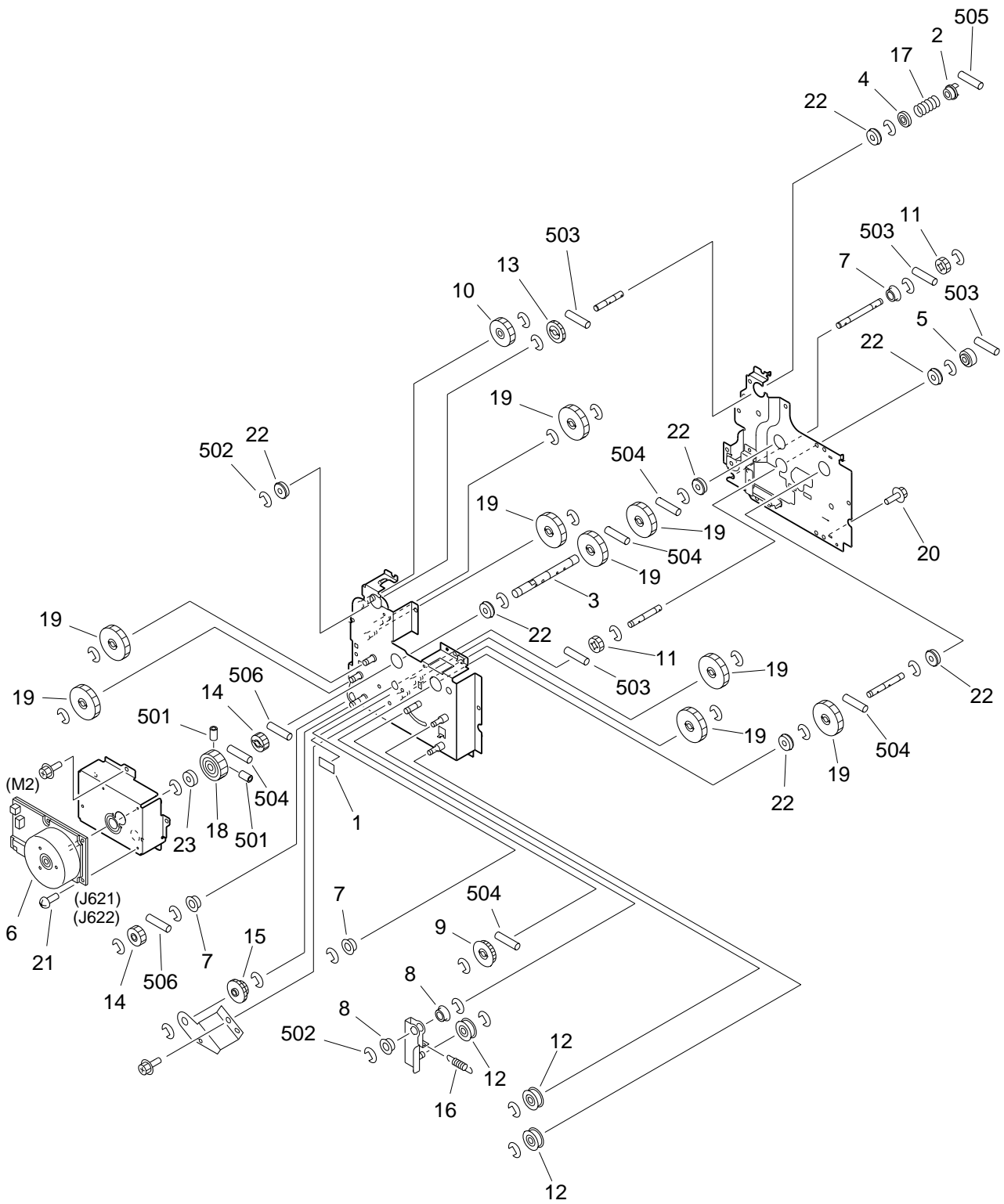

FIGURE & KEY NO.	PART NUMBER	RANK	QTY	DESCRIPTION	SERIAL NUMBER / REMARKS
260 -	FG6 - 8010 - 000		1	PAPER PICK-UP DRIVE ASSEMBLY 給紙駆動部	
1	FA9 - 3822 - 000		1	LABEL, DISCRIMINATE 識別ラベル	
2	FB2 - 7841 - 000		1	COUPLING, REGISTRATION レジスト カップリング	
3	FB4 - 3723 - 020		1	SHAFT, INPUT 入力軸	
4	FB4 - 3728 - 000		1	SUPPORT, COUPLING カップリング受け	
5	FB4 - 3729 - 000		1	COUPLING カップリング	
6	FH6 - 1936 - 000		1	MOTOR, BRUSHLESS ブラシレス モータ	M2 J621,622
7	FS1 - 1189 - 000		3	BUSHING ブッシング	
8	FS1 - 1449 - 000		2	BUSHING ブッシング	
9	FS2 - 3494 - 020		1	PULLEY, 39T 39T プーリ	
10	FS3 - 0165 - 000		1	GEAR, 40T 40T ギア	
11	FS4 - 0145 - 000		2	GEAR, 20T 20T ギア	
12	FS5 - 3337 - 020		3	PULLEY, IDLER アイドラ プーリ	
13	FS6 - 0056 - 000		1	GEAR, 32T 32T ギア	
14	FS6 - 0062 - 000		2	GEAR, 25T 25T ギア	
15	FS6 - 0096 - 000		1	GEAR, 20T/32T 20T/32T ギア	
16	FS6 - 2776 - 000		1	SPRING, TENSION ヒツパリ バネ	
17	FS6 - 2999 - 000		1	SPRING, COMPRESSION アッシュク バネ	
18	FS7 - 0035 - 020		1	GEAR, 68T 68T ギア	
19	FS7 - 0036 - 000		9	GEAR, 50T 50T ギア	
20	XA9 - 0628 - 000		12	SCREW, RS, M4X8 RS タイト ネジ	
21	XA9 - 1030 - 000		4	SCREW, RS, M4X12 RS タイト ネジ	
22	XG9 - 0249 - 000		7	BEARING, BALL ボール ベアリング	
23	XG9 - 0250 - 000		1	BEARING, BALL ボール ベアリング	
501	XB6 - 2401 - 008		2	SETSCREW, M4X10 ロツカク アナツキ トメネジ	
502	XD2 - 1100 - 642		31	RING, E E リング	
503	XD3 - 2200 - 142		4	PIN, DOWEL ヘイコウ ピン	
504	XD3 - 2200 - 162		5	PIN, DOWEL ヘイコウ ピン	
505	XD3 - 2300 - 142		1	PIN, DOWEL ヘイコウ ピン	
506	XD3 - 2300 - 182		2	PIN, DOWEL ヘイコウ ピン	

FIGURE 261 CASSETTE PICK-UP DRIVE ASSEMBLY
カセット給紙駆動部

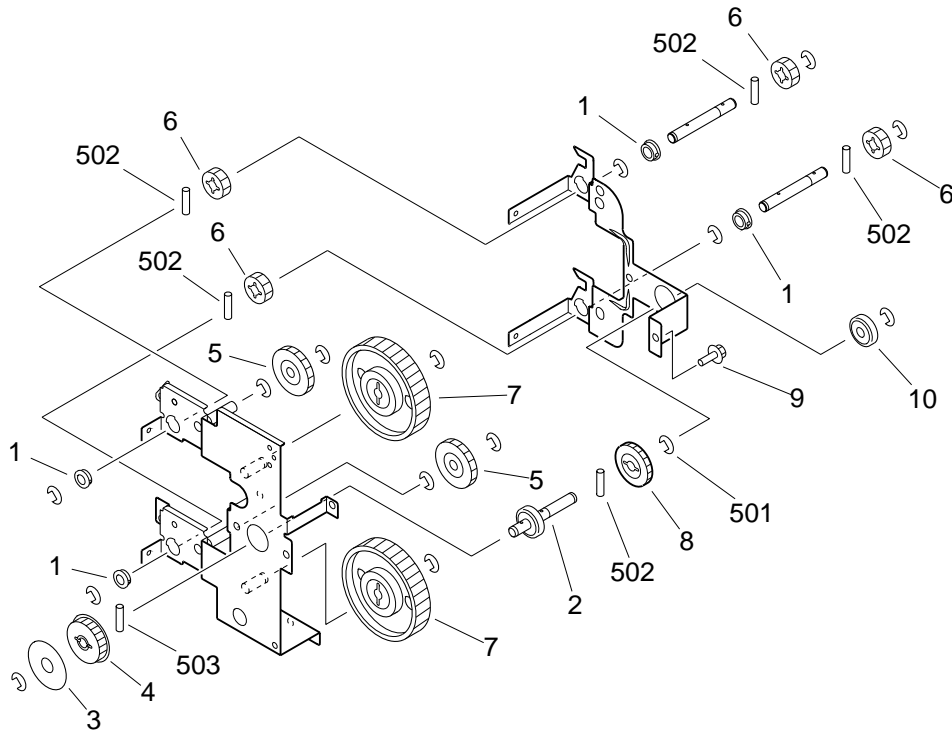

FIGURE & KEY NO.	PART NUMBER	RANK	QTY	DESCRIPTION	SERIAL NUMBER / REMARKS
261 -	FG5 - 4449 - 050		1	CASSETTE PICK-UP DRIVE ASS'Y カセット給紙駆動部	
1	FA9 - 2112 - 000		4	BUSHING ブッシング	
2	FB3 - 8615 - 000		1	SHAFT, PICK-UP PULLEY 給紙プーリ軸	
3	FB3 - 8616 - 000		1	FLANGE フランジ	
4	FS2 - 3494 - 020		1	PULLEY, 39T 39T プーリ	
5	FS4 - 0014 - 000		2	GEAR, 36T 36T ギア	
6	FS4 - 0145 - 000		4	GEAR, 20T 20T ギア	
7	FS6 - 0055 - 000		2	GEAR, 76T 76T ギア	
8	FS6 - 0056 - 000		1	GEAR, 32T 32T ギア	
9	XA9 - 0628 - 000		3	SCREW,RS,M4X8 RS タイト ネジ	
10	XG9 - 0208 - 000		1	BEARING, BALL ボール ベアリング	
501	XD2 - 1100 - 642		15	RING,E E リング	
502	XD3 - 2200 - 142		5	PIN,DOWEL ヘイコウ ピン	
503	XD3 - 2200 - 162		1	PIN,DOWEL ヘイコウ ピン	

FIGURE 263 LEFT PICK-UP DRIVE ASSEMBLY 左給紙駆動部

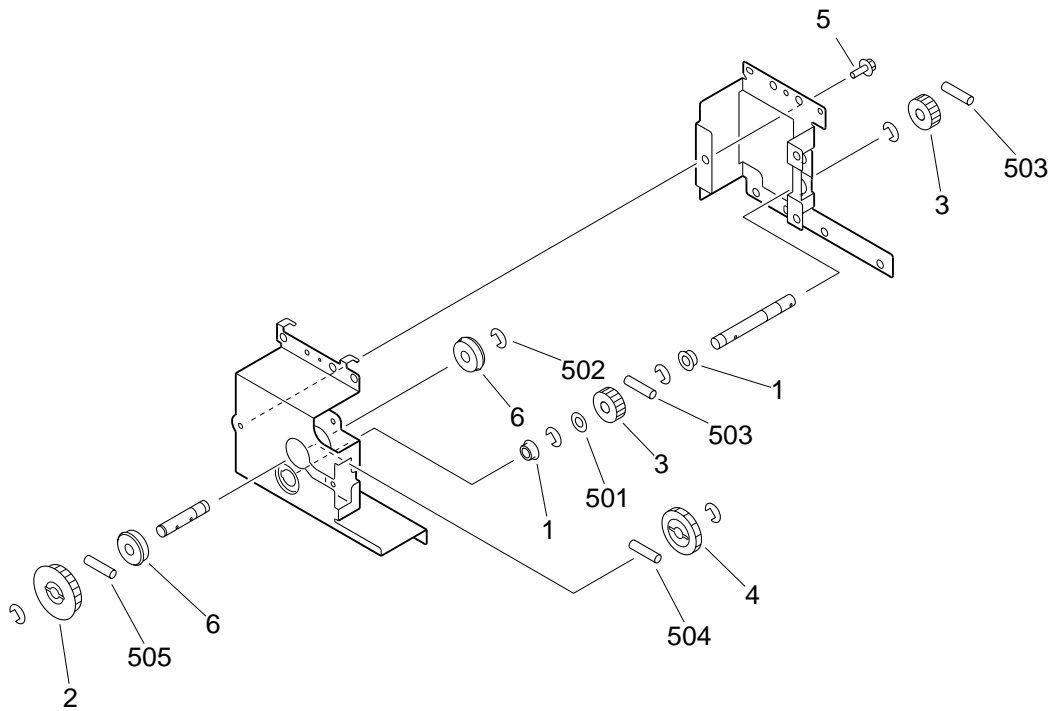
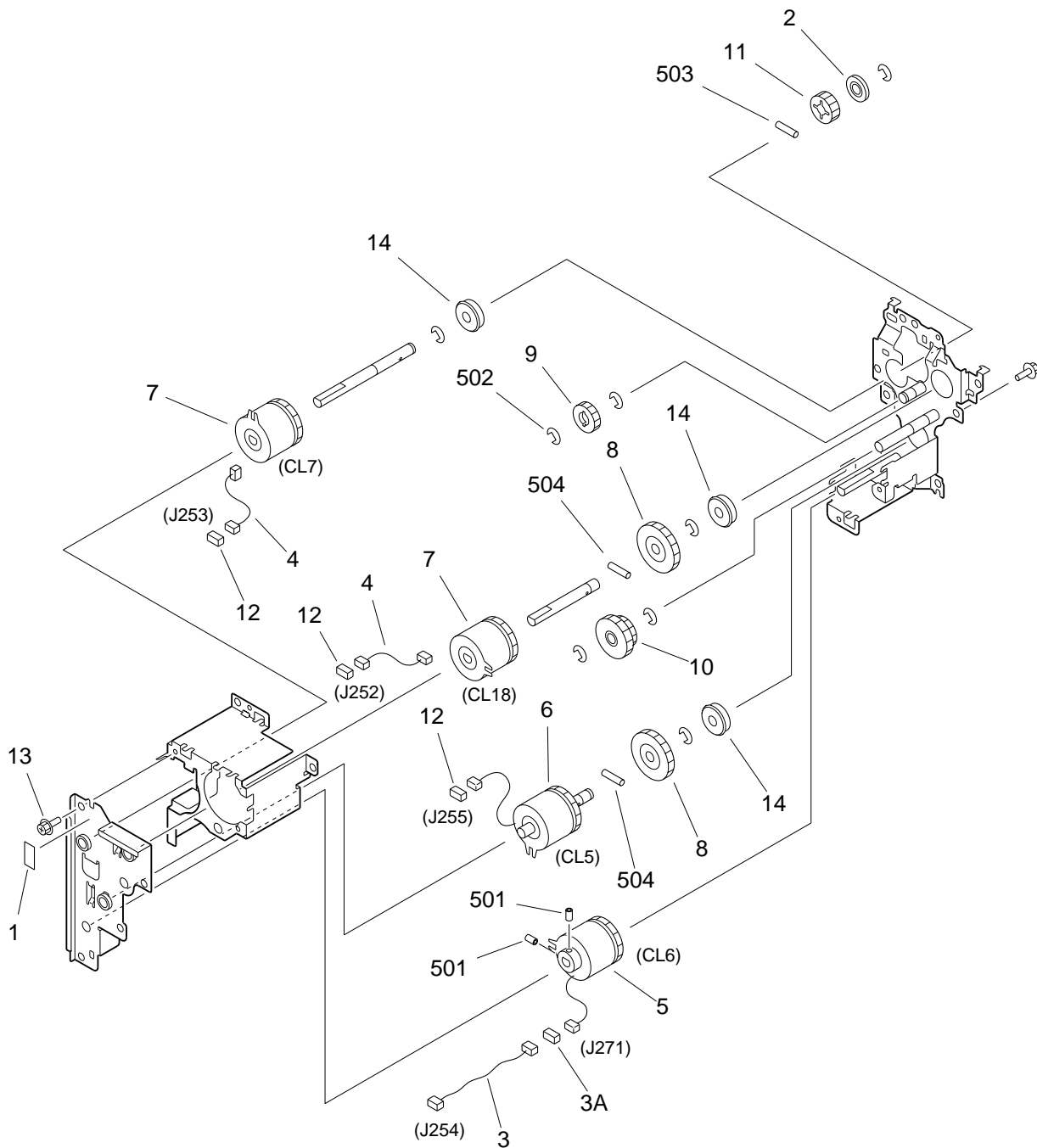

FIGURE & KEY NO.	PART NUMBER	RANK	Q'TY	DESCRIPTION	SERIAL NUMBER / REMARKS
263 -	FG6 - 1996 - 000		1	LEFT PICK-UP DRIVE ASSEMBLY 左給紙駆動部	
1	FS1 - 1189 - 000		2	BUSHING ブッシング	
2	FS2 - 3494 - 020		1	PULLEY, 39T 39T プーリ	
3	FS5 - 0514 - 000		2	GEAR, 20T 20T ギア	
4	FS6 - 0056 - 000		1	GEAR, 32T 32T ギア	
5	XA9 - 0628 - 000		5	SCREW,RS,M4X8 RS タイト ネジ	
6	XG9 - 0249 - 000		2	BEARING, BALL ボール ベアリング	
501	XD1 - 1108 - 219		1	SHIM ヒョウジュン ワッシャ	
502	XD2 - 1100 - 642		6	RING,E E リング	
503	XD3 - 2200 - 122		2	PIN,DOWEL ヘイコウ ピン	
504	XD3 - 2200 - 142		1	PIN,DOWEL ヘイコウ ピン	
505	XD3 - 2200 - 162		1	PIN,DOWEL ヘイコウ ピン	

FIGURE 264 MULTI FEED DRIVE ASSEMBLY マルチ給紙駆動部



NOTE: This assembly does not include the part shown with key No.12.
注：このユニットにKey No. 12の部品は含まれません。

FIGURE & KEY NO.	PART NUMBER	RANK	QTY	DESCRIPTION	SERIAL NUMBER / REMARKS
264 -	FG6 - 8580 - 000		1	MULTI FEED DRIVE ASSEMBLY マルチ給紙駆動部	
1	FA9 - 3822 - 000		1	LABEL, DISCRIMINATE 識別ラベル	
2	FB4 - 3767 - 000		1	COLLAR, PUSH-ON 突き当てコロ	
3	FG6 - 3572 - 000		1	CABLE, MULTI FEED DRIVE マルチ給紙駆動中継束線	J254,271
3 A	VS1 - 5057 - 002		1	CONNECTOR, SNAP TIGHT チュウケイ コネクタ	J271
4	FG6 - 8623 - 000		2	CABLE, CLUTCH クラッチ束線	J252,253
5	FH6 - 5014 - 000		1	CLUTCH, ELECTROMAGNETIC 電磁クラッチ	CL6 J271
6	FH6 - 5016 - 000		1	CLUTCH, ELECTROMAGNETIC 電磁クラッチ	CL5 J255
7	FH6 - 5043 - 000		2	CLUTCH, ELECTROMAGNETIC 電磁クラッチ	CL7,18
8	FS4 - 0014 - 000		2	GEAR, 36T 36T ギア	
9	FS6 - 0053 - 020		1	GEAR, 20T 20T ギア	
10	FS7 - 0033 - 000		1	GEAR, 24T/30T 24T / 30T ギア	
11	FS7 - 0034 - 000		1	GEAR, 20T 20T ギア	
12	VS1 - 5057 - 002		3	CONNECTOR, SNAP TIGHT チュウケイ コネクタ	SEE NOTE J252,253,255
13	XA9 - 0628 - 000		7	SCREW,RS,M4X8 RS タイト ネジ	
14	XG9 - 0249 - 000		3	BEARING, BALL ボール ベアリング	
501	XB6 - 2400 - 608		2	SETSCREW,M4X6 ロックワッシャー トメネジ	
502	XD2 - 1100 - 642		9	RING,E E リング	
503	XD3 - 2200 - 122		1	PIN,DOWEL ヘイコウ ピン	
504	XD3 - 2200 - 162		2	PIN,DOWEL ヘイコウ ピン	

FIGURE 270 DEVELOPING DRIVE ASSEMBLY
 現像驅動部

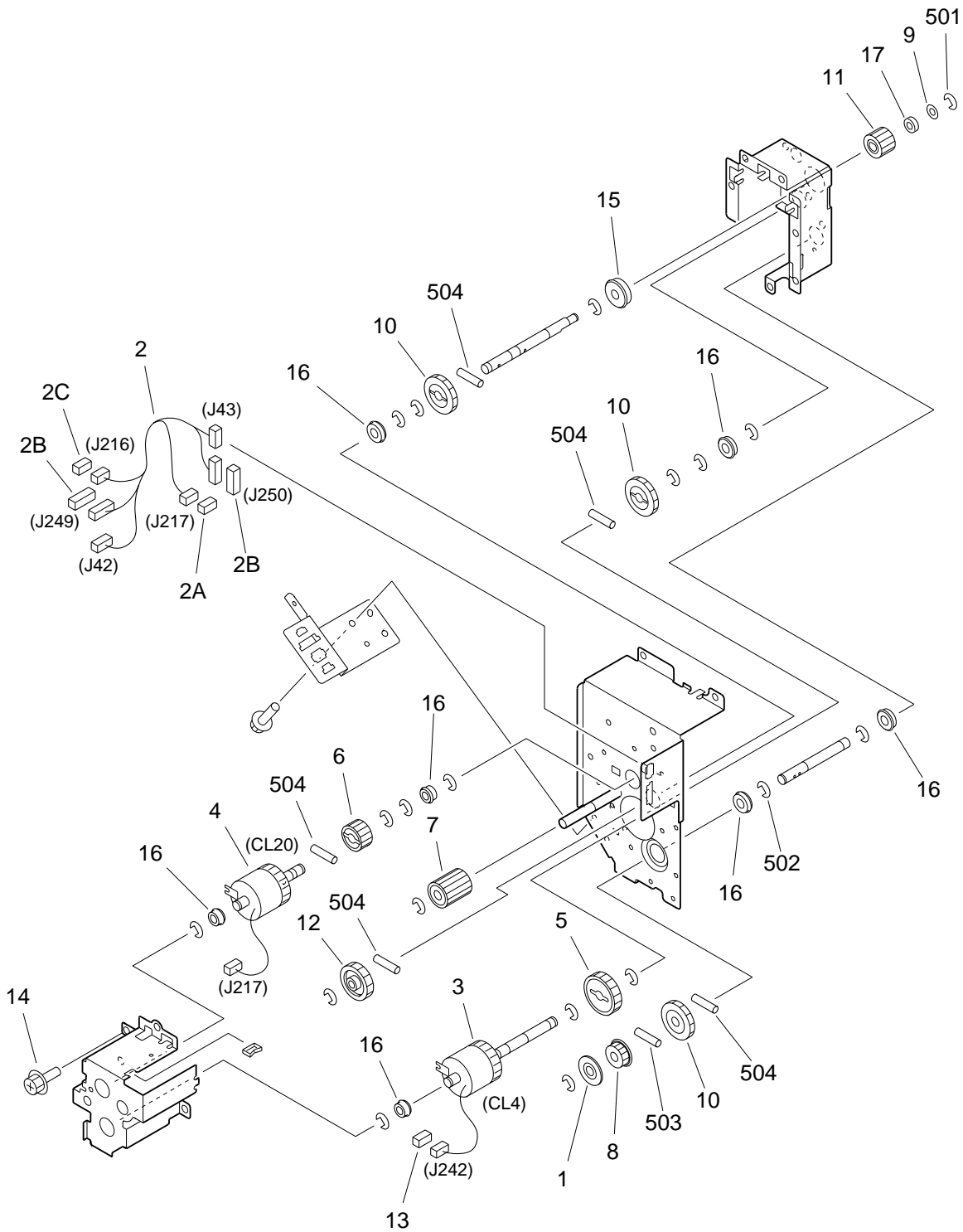
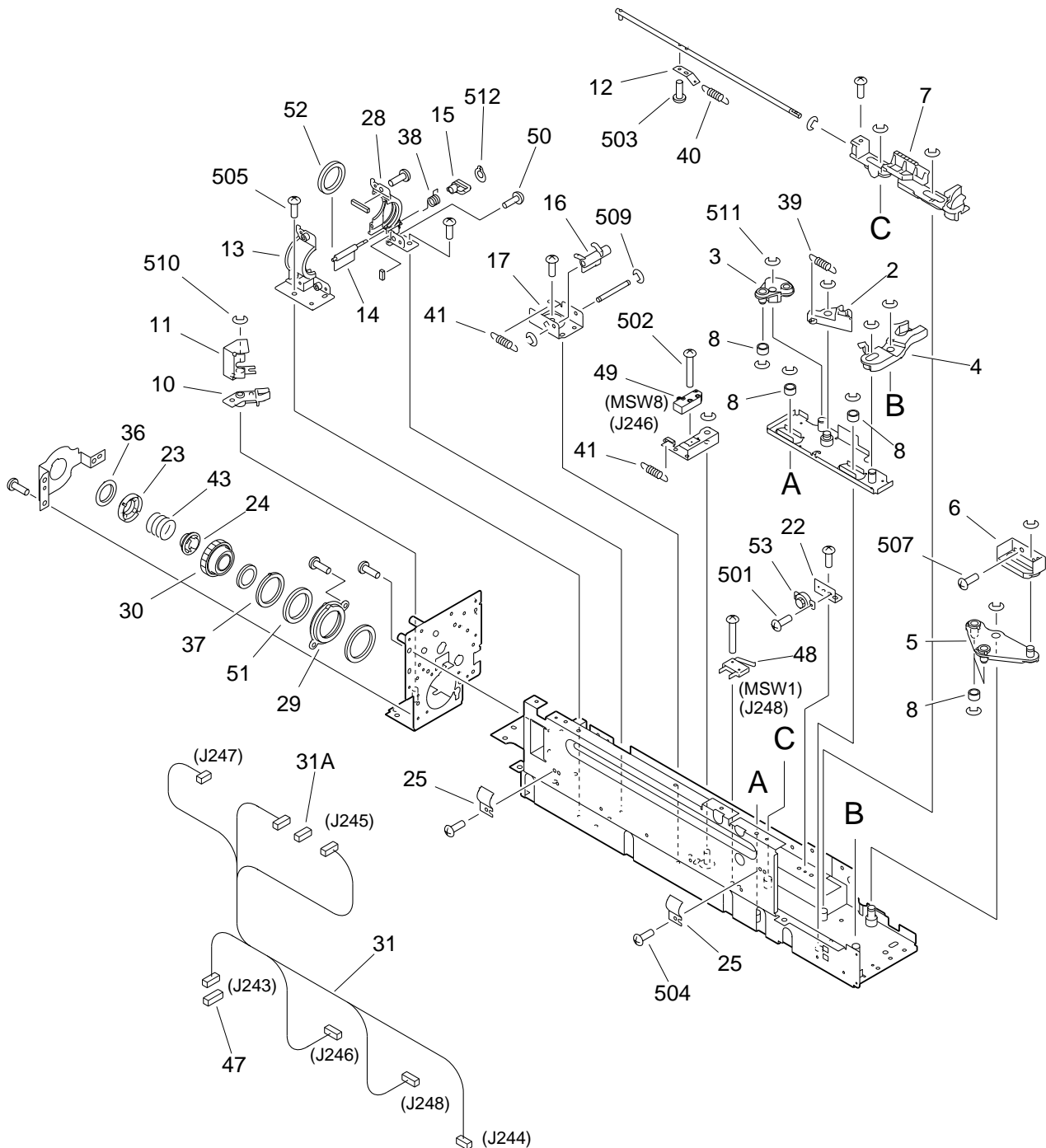

FIGURE & KEY NO.	PART NUMBER	RANK	QTY	DESCRIPTION	SERIAL NUMBER / REMARKS
270 -	FG6 - 7327 - 000		1	DEVELOPING DRIVE ASSEMBLY 現像駆動部	
1	FB4 - 1806 - 000		1	FLANGE フランジ	
2	FG6 - 7214 - 000		1	CABLE, MAIN DRIVE メイン駆動束線	J42,43,216,217,249 J250
2A	VS1 - 5057 - 002		1	CONNECTOR, SNAP TIGHT チュウケイ コネクタ	J217
2B	VS1 - 5057 - 007		2	CONNECTOR, SNAP TIGHT チュウケイ コネクタ	J249,250
2C	VS1 - 6318 - 002		1	CONNECTOR, SNAP TIGHT 中継コネクタ	J216
3	FH6 - 5015 - 000		1	CLUTCH, ELECTROMAGNETIC 電磁クラッチ	CL4 J242
4	FH6 - 5017 - 000		1	CLUTCH, ELECTROMAGNETIC 電磁クラッチ	CL20 J217
5	FS2 - 0485 - 000		1	GEAR, 32T 32T ギア	
6	FS3 - 0046 - 000		1	GEAR, 20T 20T ギア	
7	FS4 - 0157 - 000		1	GEAR, 20T 20T ギア	
8	FS5 - 3889 - 000		1	PULLEY, 20T 20T プーリ	
9	FS5 - 6488 - 000		1	WASHER ワッシャ	
10	FS6 - 0056 - 000		3	GEAR, 32T 32T ギア	
11	FS7 - 0015 - 000		1	GEAR, 23T 23T ギア	
12	FS7 - 0072 - 000		1	GEAR, 27T 27T ギア	
13	VS1 - 5057 - 002		1	CONNECTOR, SNAP TIGHT チュウケイ コネクタ	J242
14	XA9 - 0628 - 000		11	SCREW,RS,M4X8 RS タイト ネジ	
15	XG9 - 0249 - 000		1	BEARING, BALL ボール ベアリング	
16	XG9 - 0250 - 000		7	BEARING, BALL ボール ベアリング	
17	XG9 - 0395 - 000		1	BEARING, BALL ボール ベアリング	
501	XD2 - 1100 - 502		1	RING,E E リング	
502	XD2 - 1100 - 642		13	RING,E E リング	
503	XD3 - 2200 - 122		1	PIN,DOWEL ヘイコウ ピン	
504	XD3 - 2200 - 142		5	PIN,DOWEL ヘイコウ ピン	

FIGURE 275 TONER CARTRIDGE DRIVE ASSEMBLY(1/2)
トナーカートリッジ駆動部(1/2)



NOTE: This assembly does not include the part shown with key No. 47.
注: このユニットにKey No. 47の部品は含まれません。

FIGURE 275 TONER CARTRIDGE DRIVE ASSEMBLY(2/2)
 トナーカートリッジ駆動部(2/2)

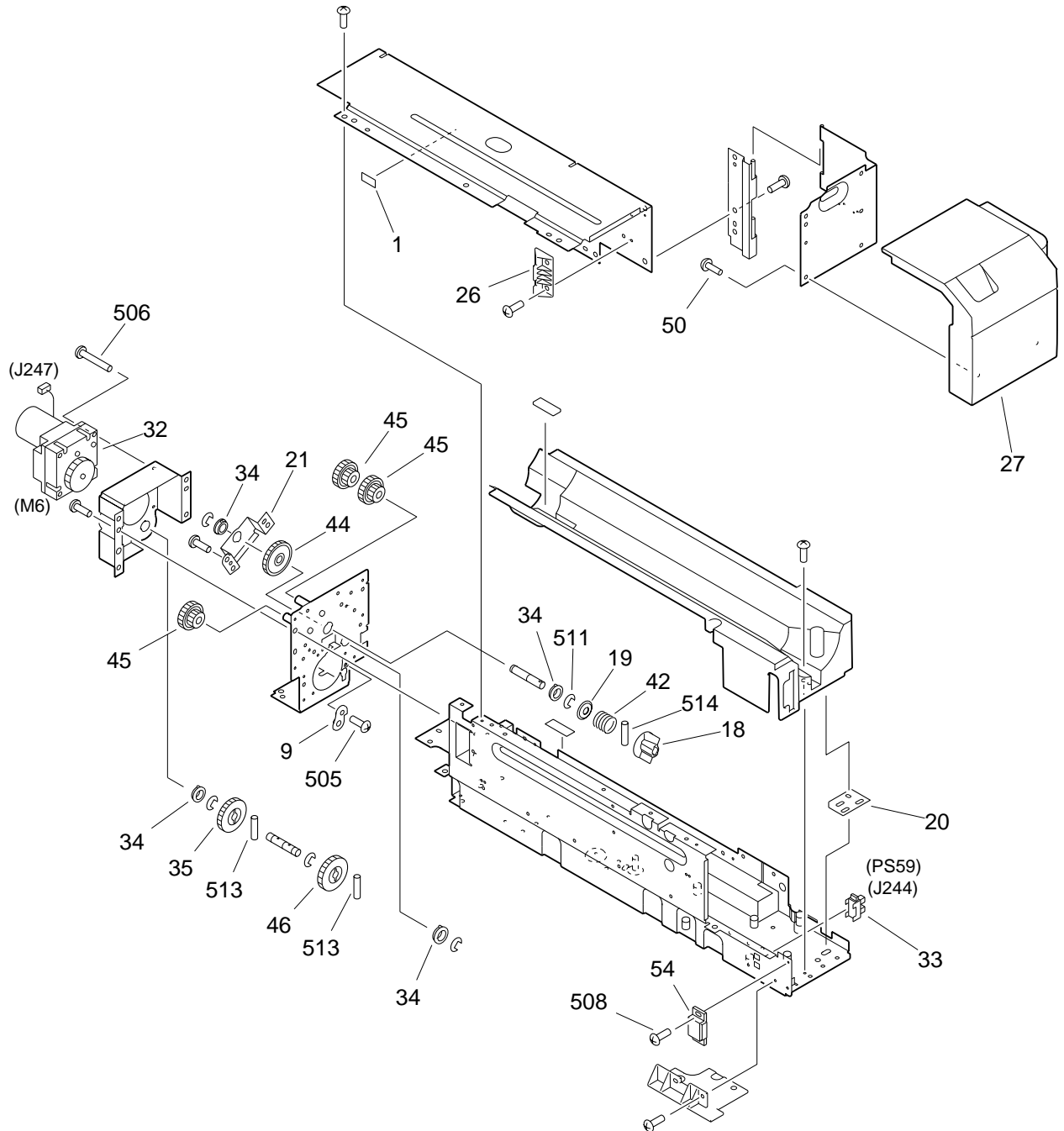

FIGURE & KEY NO.	PART NUMBER	R A N K	Q' T Y	DESCRIPTION	SERIAL NUMBER / REMARKS
275 -	FG6 - 8024 - 000		1	TONER CARTRIDGE DRIVE ASSEMBLY トナー カートリッジ駆動部	
1	FA9 - 3822 - 000		1	LABEL, DISCRIMINATE 識別ラベル	
2	FB4 - 1892 - 000		1	ARM, SEPARATION 分離アーム	
3	FB4 - 1893 - 000		1	HOLDER, BUSHING 軸受けホルダ	
4	FB4 - 1894 - 000		1	LINK, CHUCK チャック リンク	
5	FB4 - 1895 - 000		1	LEVER, CAM カム レバー	
6	FB4 - 1896 - 000		1	COVER, RAIL レール カバー	
7	FB4 - 1899 - 000		1	MOUNT, SLIDE スライド台	
8	FB4 - 1900 - 000		5	ROLLER コロ	
9	FB4 - 1901 - 000		1	BUSHING ブッシング	
10	FB4 - 1902 - 000		1	MOUNT, CAP キャップ台	
11	FB4 - 1903 - 000		1	PLATE, CHUCK CAP チャック キャップ	
12	FB4 - 1904 - 000		1	PLATE, SHAFT SUPPORT 軸支え板	
13	FB4 - 1913 - 000		1	MOUNT, RUBBER, LEFT ゴム台 (左)	
14	FB4 - 1915 - 000		1	SHUTTER シャッター	
15	FB4 - 1916 - 000		1	LEVER, SHUTTER シャッター レバー	
16	FB4 - 1924 - 000		1	LEVER, SENSOR 検知レバー	
17	FB4 - 1925 - 000		1	MOUNT, LEVER レバー支持台	
18	FB4 - 1926 - 000		1	COUPLING カップリング	
19	FB4 - 1927 - 000		1	SUPPORT, SPRING ばね押さえ	
20	FB4 - 5309 - 000		1	PLATE, HINGE ADJUSTING ヒンジ調整板	
21	FB4 - 5310 - 000		1	MOUNT, SHAFT 軸支え板	
22	FB4 - 9026 - 000		1	PLATE, DAMPER SUPPORT ダンパ支持板	
23	FB4 - 9027 - 000		1	GEAR, CAP, REAR キャップ ギア (後)	
24	FB4 - 9028 - 000		1	CLAW, DRIVE 駆動爪	
25	FB4 - 9514 - 000		2	PLATE, GROUNDING アース板	
26	FB5 - 6877 - 000		1	GUIDE ガイド	
27	FB6 - 0445 - 000		1	COVER, CARTRIDGE, FRONT カートリッジ カバー (前)	
28	FF5 - 7715 - 000		1	MOUNT, RUBBER, RIGHT ゴム台 (右)	
29	FF5 - 8655 - 000		1	CASE, GEAR HOLDER ギア軸受ケース	

FIGURE & KEY NO.	PART NUMBER	RANK	QTY	DESCRIPTION	SERIAL NUMBER / REMARKS
275 - 30	FF5 - 8732 - 000		1	GEAR, CAP, FRONT キャップ ギア(前)	
31	FG6 - 1889 - 000		1	CABLE, CARTRIDGE カートリッジ束線	J243-248
31 A	VS1 - 5057 - 002		1	CONNECTOR, SNAP TIGHT チュウケイ コネクタ	J245
32	FH6 - 1538 - 000		1	MOTOR, DC 9.6W DCモ - タ	M6 J247
33	FH7 - 7462 - 000		1	PHOTO-INTERRUPTER フォトインタラプタ	PS59 J244
34	FS1 - 1510 - 000		4	BUSHING ブッシング	
35	FS3 - 0098 - 000		1	GEAR, 35T 35T ギア	
36	FS5 - 1796 - 000		1	SUPPORT, CAP GEAR, REAR キャップ ギア受け(後)	
37	FS5 - 1802 - 000		1	SUPPORT, CAP GEAR, FRONT キャップ ギア受け(前)	
38	FS5 - 2901 - 000		1	SPRING, TORSION ネジリ バネ	
39	FS6 - 2763 - 000		1	SPRING, TENSION ヒツパリ バネ	
40	FS6 - 2764 - 000		1	SPRING, TENSION ヒツパリ バネ	
41	FS6 - 2774 - 000		2	SPRING, TENSION ヒツパリ バネ	
42	FS6 - 2887 - 000		1	SPRING, COMPRESSION アッシュク バネ	
43	FS6 - 2998 - 000		1	SPRING, COMPRESSION アッシュク バネ	
44	FS7 - 0043 - 000		1	GEAR, 36T 36T ギア	
45	FS7 - 0044 - 000		3	GEAR, 16T/28T 16T / 28T ギア	
46	FS7 - 0051 - 000		1	GEAR, 36T 36T ギア	
47	VS1 - 5057 - 007		1	CONNECTOR, SNAP TIGHT チュウケイ コネクタ	SEE NOTE J243
48	WC4 - 5153 - 000		1	MICRO SWITCH マイクロ スイッチ	MSW1 J248
49	WC4 - 5157 - 000		1	MICRO SWITCH マイクロ スイッチ	MSW8 J246
50	XA9 - 0605 - 000		6	SCREW, M4X8 タイト ネジ	
51	XG9 - 0175 - 000		1	SEAL, OIL オイル シール	
52	XG9 - 0385 - 000		1	PACKING パッキン	
53	XH9 - 0090 - 000		1	OIL DAMPER UNIT オイル ダンパ ユニット	
54	XZ9 - 0472 - 000		1	CATCH, MAGNET マグネット キャッチ	
501	XB1 - 1200 - 405		2	SCREW, MACH., PAN HEAD, M2X4 ナベ ネジ	
502	XB1 - 2231 - 009		2	SCREW, MACH., TRUSS HEAD, M2.3X10 バインド ネジ	
503	XB1 - 2300 - 609		3	SCREW, MACH., TRUSS HEAD, M3X6 バインド ネジ	
504	XB1 - 2400 - 607		2	SCREW, MACH., TRUSS HEAD, M4X6 バインド ネジ	

FIGURE & KEY NO.	PART NUMBER	RANK	QTY	DESCRIPTION	SERIAL NUMBER / REMARKS
275 - 505	XB1 - 2400 - 609		33	SCREW,MACH.,TRUSS HEAD,M4X6 バインド ネジ	
506	XB1 - 2402 - 509		3	SCREW,MACH.,TRUSS HEAD,M4X25 バインド ネジ	
507	XB2 - 8400 - 809		2	SCREW,W/WASHER,M4X8 パネツキ バインド ネジ	
508	XB6 - 7300 - 809		2	SCREW,TP,M3X8 TP ネジ	
509	XD2 - 1100 - 322		2	RING,E E リング	
510	XD2 - 1100 - 502		6	RING,E E リング	
511	XD2 - 1100 - 642		15	RING,E E リング	
512	XD2 - 2100 - 302		1	RING,GRIP グリップ リング	
513	XD3 - 2200 - 142		2	PIN,DOWEL ヘイコウ ピン	
514	XD3 - 2300 - 122		1	PIN,DOWEL ヘイコウ ピン	

FIGURE 280 WASTE TONER DRIVE ASSEMBLY
廃トナー駆動部

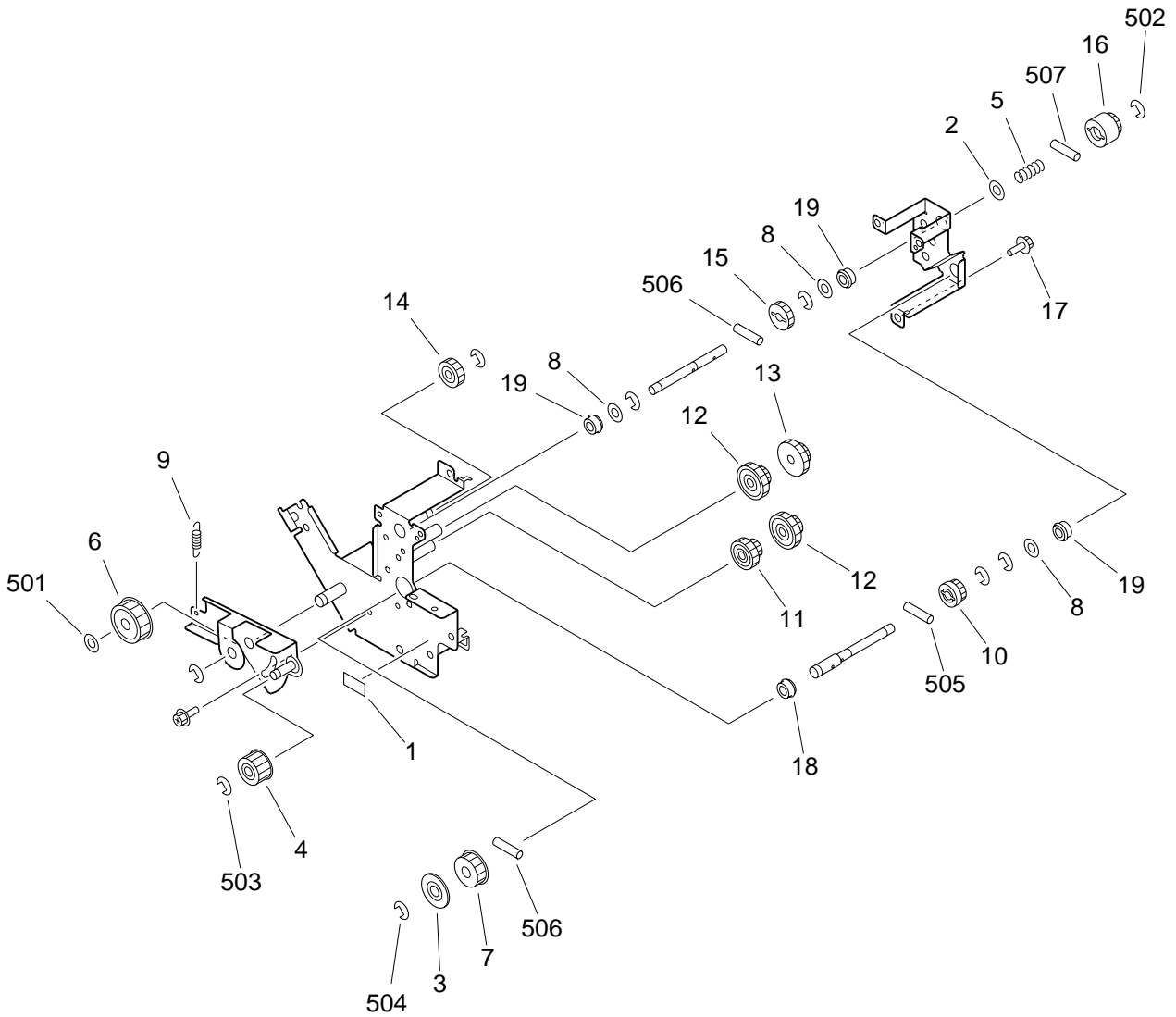

FIGURE & KEY NO.	PART NUMBER	R A N K	Q' T Y	DESCRIPTION	SERIAL NUMBER / REMARKS
280 -	FG6 - 7328 - 000		1	WASTE TONER DRIVE ASSEMBLY 廃トナー駆動部	
1	FA9 - 3805 - 000		1	LABEL, DISCRIMINATE 識別ラベル	
2	FB4 - 1762 - 000		1	RING, SPRING SUPPORT バネ座	
3	FB4 - 1806 - 000		1	FLANGE フランジ	
4	FS2 - 3495 - 000		1	PULLEY プーリ	
5	FS5 - 2959 - 000		1	SPRING, COMPRESSION アッシュク バネ	
6	FS5 - 3610 - 000		1	PULLEY, 30T 30T プーリ	
7	FS5 - 3890 - 000		1	PULLT, 18T 18T プーリ	
8	FS5 - 6488 - 000		3	WASHER ワッシャ	
9	FS6 - 2752 - 000		1	SPRING, TENSION ヒツパリ バネ	
10	FS7 - 0020 - 000		1	GEAR, 29T 29T ギア	
11	FS7 - 0021 - 000		1	GEAR, 24T/40T 24T / 40T ギア	
12	FS7 - 0022 - 000		2	GEAR, 24T/48T 24T / 48T ギア	
13	FS7 - 0023 - 000		1	GEAR, 28T/48T 28T / 48T ギア	
14	FS7 - 0024 - 000		1	GEAR, 36T 36T ギア	
15	FS7 - 0025 - 000		1	GEAR, 36T 36T ギア	
16	FS7 - 0026 - 000		1	GEAR, 18T 18T ギア	
17	XA9 - 0628 - 000		4	SCREW,RS,M4X8 RS タイト ネジ	
18	XG9 - 0250 - 000		1	BEARING, BALL ボール ベアリング	
19	XG9 - 0350 - 000		3	BALL BEARING, MF106ZZ1MC3 ボール ベアリング	
501	XD1 - 1108 - 222		1	SHIM ヒョウジュン ワッシャ	
502	XD2 - 1100 - 322		1	RING,E E リング	
503	XD2 - 1100 - 502		6	RING,E E リング	
504	XD2 - 1100 - 642		2	RING,E E リング	
505	XD3 - 2200 - 102		1	PIN,DOWEL ヘイコウ ピン	
506	XD3 - 2200 - 122		2	PIN,DOWEL ヘイコウ ピン	
507	XD3 - 2200 - 142		1	PIN,DOWEL ヘイコウ ピン	

FIGURE 300 CASSETTE カセット

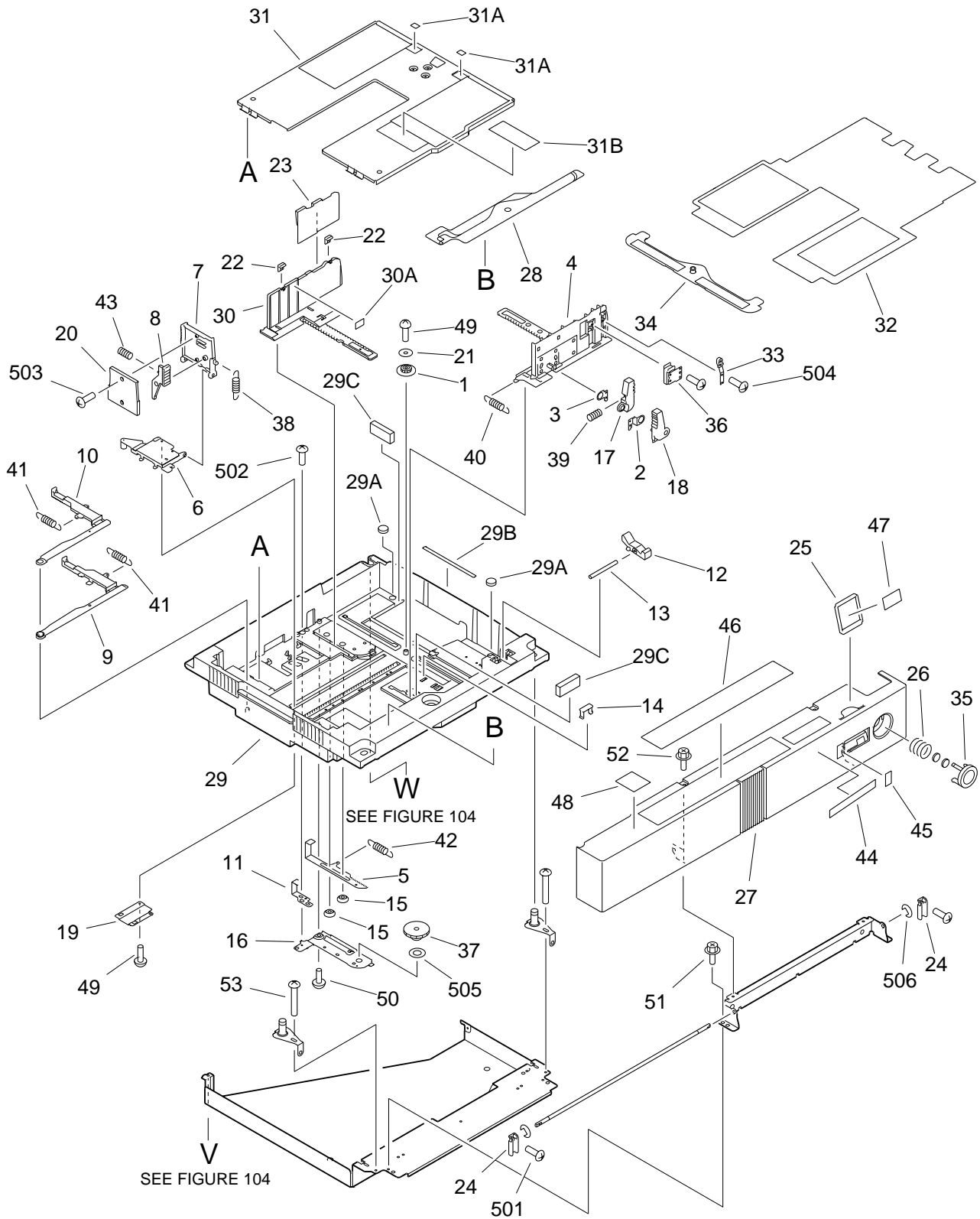
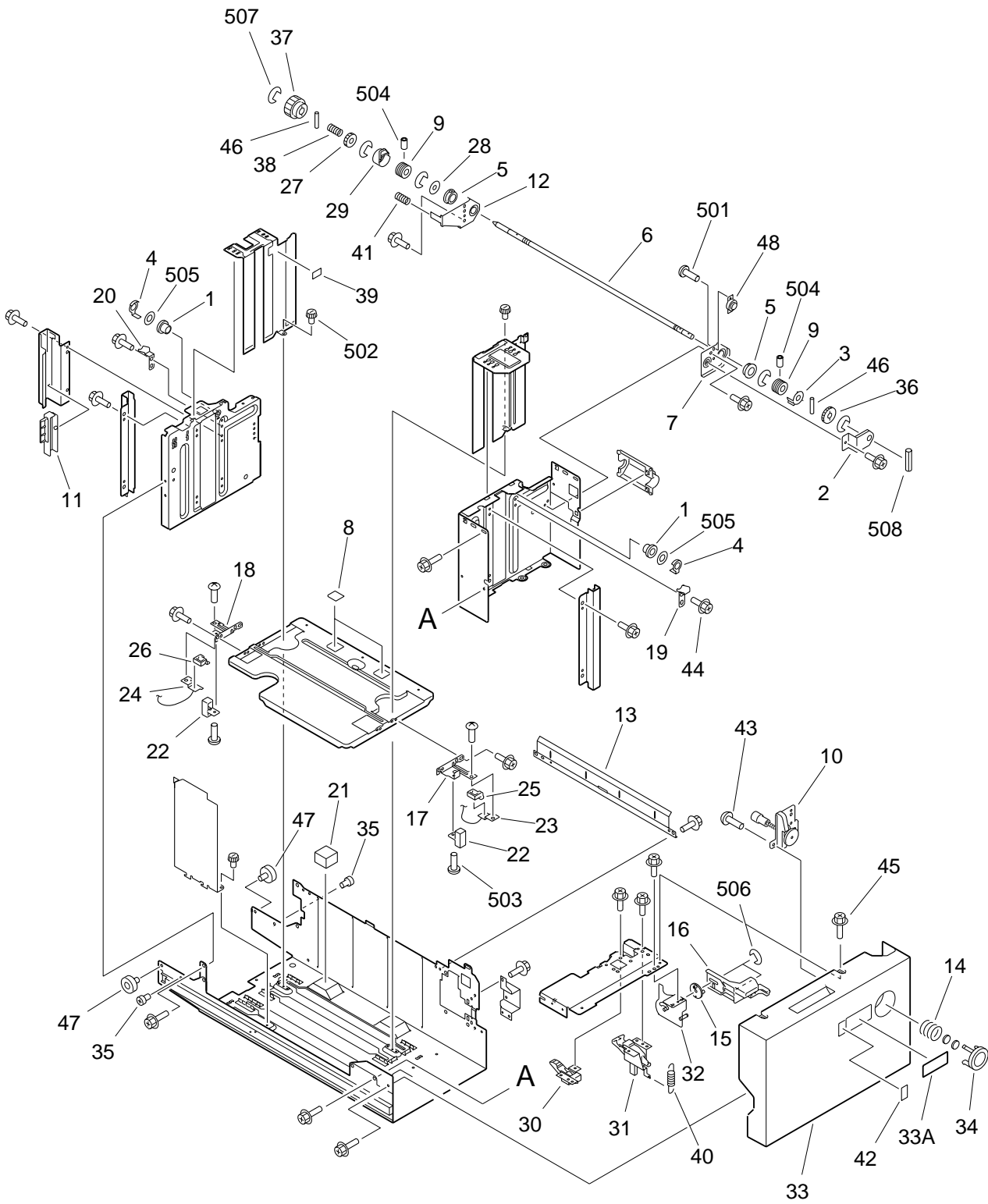

FIGURE & KEY NO.	PART NUMBER	RANK	QTY	DESCRIPTION	SERIAL NUMBER / REMARKS
300 -	NPN		RF	CASSETTE カセット	
1	FA9 - 3674 - 000		1	GEAR, 17T 17T ギア	
2	FB2 - 6043 - 000		1	PLATE, CATCH, 1 つまみ板 (1)	
3	FB2 - 6044 - 000		1	PLATE, CATCH, 2 つまみ板 (2)	
4	FB3 - 9303 - 020		1	PLATE, SIDE GUIDE, FRONT サイド規制板 (前)	
5	FB3 - 9305 - 000		1	PLATE, VOLUME RACK ボリューム ラック	
6	FB3 - 9306 - 000		1	MOUNT, END GUIDE 後端規制台	
7	FB3 - 9307 - 000		1	PLATE, END GUIDE 後端規制板	
8	FB3 - 9308 - 000		1	LEVER, END GUIDE 後端規制レバー	
9	FB3 - 9311 - 000		1	CAM, END PLATE SENSING, 1 後端検知カム (1)	
10	FB3 - 9312 - 000		1	CAM, END PLATE SENSING, 2 後端検知カム (2)	
11	FB3 - 9313 - 000		1	PLATE, VOLUME ボリューム コマ	
12	FB3 - 9314 - 000		1	LEVER, RELEASE 解除レバー	
13	FB3 - 9315 - 000		1	SHAFT, RELEASE LEVER 解除レバー軸	
14	FB3 - 9316 - 000		3	CLAW, SENSING 誤検知防止爪	
15	FB3 - 9319 - 000		2	BUSHING ブッシング	
16	FB3 - 9320 - 000		1	PLATE, COVER, LOWER カバー支板 (下)	
17	FB3 - 9322 - 020		1	KNOB, SIDE GUIDE, 1 サイド規制板つまみ (1)	
18	FB3 - 9323 - 030		1	KNOB, SIDE GUIDE, 2 サイド規制板つまみ (2)	
19	FB3 - 9326 - 000		1	PLATE, END GUIDE, LOWER 後端規制支板 (下)	
20	FB3 - 9327 - 000		1	COVER, END GUIDE PLATE 後端規制板カバー	
21	FB3 - 9335 - 000		1	RING, GEAR STOP ギア押え	
22	FB3 - 9337 - 000		2	CLAW, SIDE GUIDE PLATE サイド爪	
23	FB3 - 9340 - 000		1	COVER, SIDE GUIDE PLATE サイド規制板カバー	
24	FB4 - 5253 - 000		2	LINK, CASSETTE カセット リンク	
25	FB5 - 1489 - 000		1	PLATE, SIZE サイズ プレート	
26	FB5 - 3365 - 000		1	SPRING, COMPRESSION アッシュク バネ	
27	FB5 - 6987 - 000		1	COVER, CASSETTE, FRONT カセット カバー (前)	
28	FB5 - 9351 - 000		1	SHEET, TAB ATTACHMENT タブ装着シート	
29	FF5 - 6183 - 000	N	1	BODY, CASSETTE カセット オケ	

FIGURE & KEY NO.	PART NUMBER	RANK	QTY	DESCRIPTION	SERIAL NUMBER / REMARKS
300 - 29A	FB3 - 9321 - 000		2	SHEET, DAMPER ダンパ シート	
29B	FB3 - 9329 - 000		1	LABEL, CASSETTE GRIP, RIGHT カセット 把手ラベル (右)	
29C	FB3 - 9336 - 000		2	PAD, SILENCER 消音パッド	
30	FF5 - 6189 - 000		1	PLATE, SIDE GUIDE, REAR サイド規制板 (後)	
30A	FS5 - 8618 - 000		1	LABEL, "MAXIMUM LOAD" 積載制限ラベル	
31	FF5 - 9550 - 000		1	PLATE, LIFTING 中板	
31A	FB5 - 2841 - 000		2	SHEET, SEPARATION 分離シート	
31B	FS5 - 8619 - 000		1	LABEL, SIZE サイズ ラベル	
32	FF6 - 1019 - 000		1	SHEET, TAB タブ下敷きシート	
33	FF6 - 1034 - 000		1	SPRING, LEAF, 1 板バネ (1)	
34	FF6 - 1052 - 000		1	COVER, WEIGHT 重し蓋	A4 TYPE
	FF6 - 1051 - 000		1	COVER, WEIGHT 重し蓋	LTR TYPE
35	FF6 - 1054 - 000		1	BUTTON, PUSH プッシュ ボタン	
36	FF6 - 1333 - 000		1	SPRING, LEAF, 2 板バネ (2)	
37	FS5 - 0532 - 000		1	GEAR, 15T/42T 15T / 42T ギア	
38	FS5 - 2328 - 000		1	SPRING, TENSION ヒツパリ バネ	
39	FS5 - 2650 - 000		1	SPRING, COMPRESSION アッシュク バネ	
40	FS6 - 2691 - 000		1	SPRING, TENSION ヒツパリ バネ	
41	FS6 - 2692 - 000		2	SPRING, TENSION ヒツパリ バネ	
42	FS6 - 2693 - 000		1	SPRING, TENSION ヒツパリ バネ	
43	FS6 - 2694 - 000		1	SPRING, COMPRESSION アッシュク バネ	
44	FS6 - 8411 - 000		1	LABEL, "UNIVERSAL" ユニバーサル カセット ラベル	
45	FS6 - 8980 - 000		1	LABEL, NUMBER ナンバ ラベル	
46	FS6 - 8982 - 000		1	LABEL, CASSETTE OPERATION カセット 操作説明ラベル	
47	FS6 - 8990 - 000		1	LABEL, SIZE カセット サイズ ラベル	
48	FS7 - 8287 - 000		1	LABEL, PAPER SET 3穴紙セット ラベル	
49	XA9 - 0591 - 000		3	SCREW, M3X8 タイト ネジ	
50	XA9 - 0605 - 000		2	SCREW, M4X8 タイト ネジ	
51	XA9 - 0628 - 000		10	SCREW, RS, M4X8 RS タイト ネジ	
52	XA9 - 0628 - 000		5	SCREW, RS, M4X8 RS タイト ネジ	

FIGURE & KEY NO.	PART NUMBER	R A N K	Q' T Y	DESCRIPTION	SERIAL NUMBER / REMARKS
300 - 53	XA9 - 0721 - 000		2	SCREW,RS,M4X10 RS タイト ネジ	
501	XB1 - 2300 - 609		2	SCREW,MACH.,TRUSS HEAD,M3X6 バインド ネジ	
502	XB1 - 2400 - 609		1	SCREW,MACH.,TRUSS HEAD,M4X6 バインド ネジ	
503	XB4 - 7300 - 607		2	SCREW,TAPPING,TRUSS HEAD,M3X6 バインド タッピン ネジ	
504	XB4 - 7300 - 607		2	SCREW,TAPPING,TRUSS HEAD,M3X6 バインド タッピン ネジ	
505	XD1 - 1108 - 235		1	SHIM ヒョウジュン ワッシャ	
506	XD2 - 1100 - 502		2	RING,E E リング	

FIGURE 302 1.5K RIGHT PAPER STOCK ASSEMBLY
 1.5K右収納庫部



NOTE: This assembly does not include the part shown with key No. 42.
 注：このユニットにKey No. 42の部品は含まれません。

FIGURE & KEY NO.	PART NUMBER	RANK	QTY	DESCRIPTION	SERIAL NUMBER / REMARKS
302 -	FG6 - 7376 - 000		1	1.5K RIGHT PAPER STOCK ASS'Y 1.5K右収納庫部	
1	FA6 - 9971 - 000		2	PULLEY, IDLER アイドラ プーリ	
2	FA6 - 9986 - 000		1	HOLDER, DAMPER ダンパ トリツケ バン	
3	FA6 - 9988 - 020		1	FLANGE, LIFTER リフト フランジ	
4	FA6 - 9989 - 000		2	FLANGE, IDLER アイドラ フランジ	
5	FA9 - 2112 - 000		2	BUSHING ブッシング	
6	FB2 - 7625 - 000		1	SHAFT, LIFT リフト軸	
7	FB2 - 7652 - 000		1	SUPPORT, SHAFT, FRONT 軸支板 (前)	
8	FB2 - 7740 - 020		2	SHEET, SEPARATION 分離シート	
9	FB2 - 8465 - 000		2	PULLEY, LIFTING, FRONT リフト プーリ (前)	
10	FB3 - 8508 - 000		1	PAPER QUANTITY INDICATOR UNIT 残量表示ユニット	
11	FB4 - 2026 - 000		1	LEVER, SLIDE スライド レバー	
12	FB4 - 5268 - 000		1	SUPPORT, SHAFT, REAR 軸支板 (後)	
13	FB4 - 9509 - 000		1	PLATE, SEPARATION 分離板	
14	FB5 - 3365 - 000		1	SPRING, COMPRESSION アッシュク バネ	
15	FB5 - 3370 - 000		1	LEVER, HOOK RELEASE フック解除レバー	
16	FB5 - 3569 - 000		1	LEVER, HOOK RELEASE フック解除レバー	
17	FB5 - 5606 - 000		1	HOOK, WIRE, FRONT ワイヤ掛け (前)	
18	FB5 - 5607 - 000		1	HOOK, WIRE, REAR ワイヤ掛け (後)	
19	FB5 - 5608 - 000		1	SUPPORT, FRONT 支え板 (前)	
20	FB5 - 5609 - 000		1	SUPPORT, REAR 支え板 (後)	
21	FB6 - 2719 - 000		4	PAD 消音パッド	
22	FC1 - 5049 - 000		2	BRACKET スライド コマ	
23	FC1 - 5051 - 000		1	WIRE, LIFTING, FRONT ワイヤ (前)	
24	FC1 - 5052 - 000		1	WIRE, LIFTING, REAR ワイヤ (後)	
25	FC1 - 5055 - 000		1	HOLDER, CABLE, FRONT ワイヤ オサエ (前)	
26	FC1 - 5056 - 000		1	HOLDER, CABLE, REAR ワイヤ オサエ (後)	
27	FC1 - 5061 - 000		1	GEAR, 28T 28T ギア	
28	FC1 - 5080 - 000		1	PLATE, LIMIT, WIRE ワイヤ キセイ バン	
29	FC1 - 5081 - 000		1	FLANGE, REAR 1.5K リフト フランジ (後)	

FIGURE & KEY NO.	PART NUMBER	RANK	QTY	DESCRIPTION	SERIAL NUMBER / REMARKS
302 - 30	FF5 - 8150 - 000		1	LEVER, CAM RELEASE カム解除レバー	
31	FF5 - 8151 - 000		1	HOOK フック	
32	FF5 - 9791 - 000		1	PLATE, LEVER SUPPORT 解除支板	
33	FF6 - 1013 - 000		1	FRONT COVER, RIGHT 前カバー (右)	
33A	FB5 - 3366 - 000		1	PLATE, INDEX, PAPER 残量表示プレート	
34	FF6 - 1054 - 000		1	BUTTON, PUSH プッシュ ボタン	
35	FS2 - 9428 - 000		2	SCREW, M6X6 ネジ	
36	FS4 - 0012 - 000		1	GEAR, 27T 27T ギア	
37	FS4 - 0160 - 000		1	GEAR, 28T 28T ギア	
38	FS4 - 2136 - 000		1	SPRING, COMPRESSION アッシュク バネ	
39	FS5 - 8618 - 000		1	LABEL, "MAXIMUM LOAD" 積載制限ラベル	
40	FS6 - 2983 - 000		1	SPRING, TENSION ヒツパリ バネ	
41	FS6 - 2984 - 000		1	SPRING, COMPRESSION アッシュク バネ	
42	FS6 - 8981 - 000		2	LABEL, PAPER SIZE 紙サイズ ラベル	SEE NOTE
43	XA9 - 0605 - 000		2	SCREW, M4X8 タイト ネジ	
44	XA9 - 0685 - 000		28	SCREW, RS, M4X6 RS タイト ネジ	
45	XA9 - 0721 - 000		10	SCREW, RS, M4X10 RS タイト ネジ	
46	XD9 - 0104 - 000		2	PIN, DOWEL ヘイコウ ピン	
47	XG9 - 0439 - 000		2	BEARING, ROLLER ロ-ラ ベアリング	
48	XH9 - 0082 - 000		1	DAMPER, OIL オイル ダンパ	
501	XB1 - 2200 - 409		2	SCREW, MACH., TRUSS HEAD, M2X4 バインド ネジ	
502	XB1 - 2400 - 607		3	SCREW, MACH., TRUSS HEAD, M4X6 バインド ネジ	
503	XB1 - 2400 - 609		4	SCREW, MACH., TRUSS HEAD, M4X6 バインド ネジ	
504	XB6 - 2300 - 408		4	SETSCREW, M3X4 ロック アナツキ トメネジ	
505	XD1 - 1108 - 239		2	SHIM ヒョウジュン ワッシャ	
506	XD2 - 1100 - 402		2	RING, E E リング	
507	XD2 - 1100 - 642		5	RING, E E リング	
508	XD3 - 1200 - 122		1	PIN, SPRING スプリング ピン	

FIGURE 303 1.5K LEFT PAPER STOCK ASSEMBLY

1.5K左収納庫部

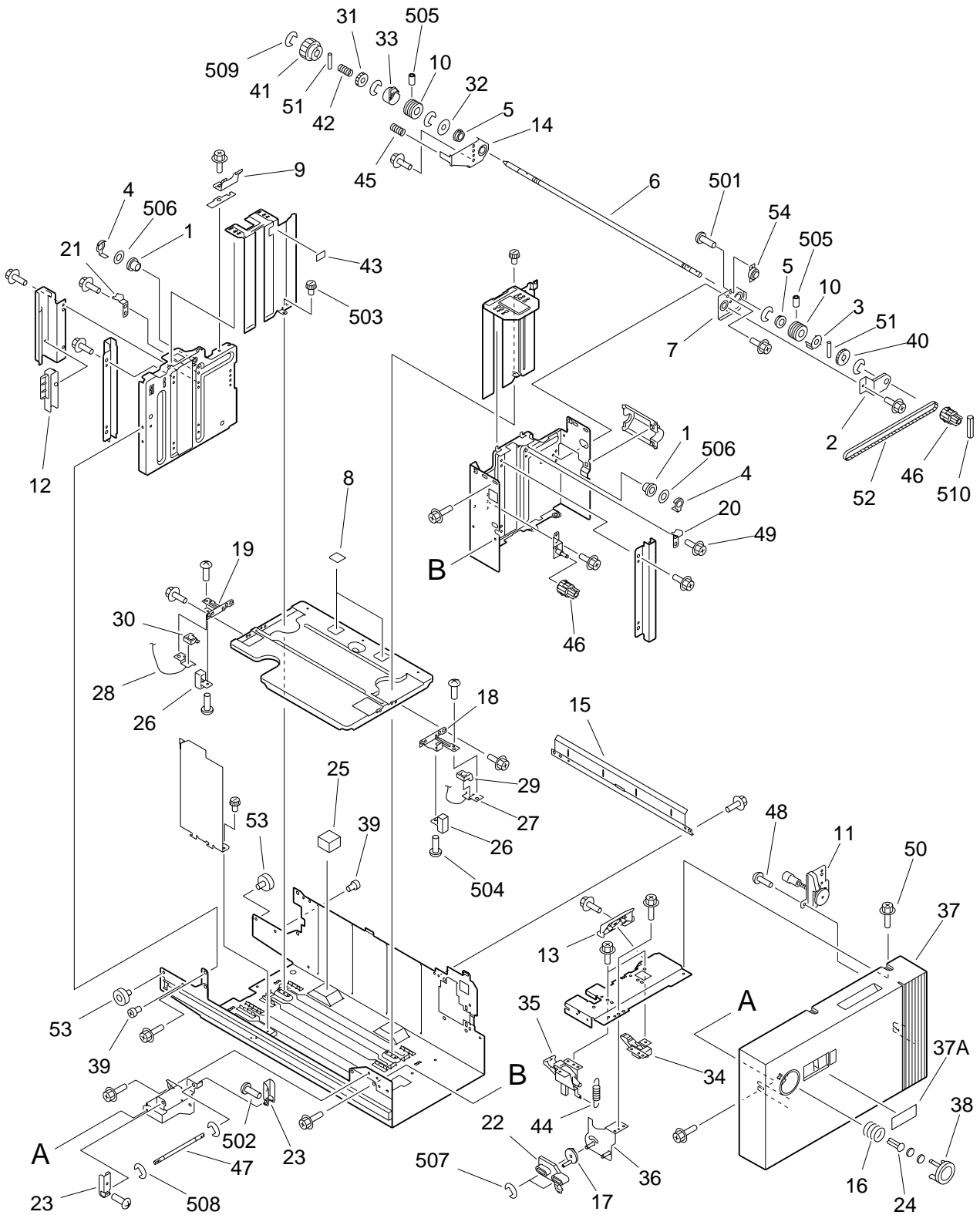

FIGURE & KEY NO.	PART NUMBER	RANK	QTY	DESCRIPTION	SERIAL NUMBER / REMARKS
303 - 1 2 3 4	FG6 - 7377 - 000		1	1.5K LEFT PAPER STOCK ASSEMBLY 1.5K左収納庫部	
	FA6 - 9971 - 000		2	PULLEY, IDLER アイドラ プーリ	
	FA6 - 9986 - 000		1	HOLDER, DAMPER ダンパ トリツケ バン	
	FA6 - 9988 - 020		1	FLANGE, LIFTER リフト フランジ	
	FA6 - 9989 - 000		2	FLANGE, IDLER アイドラ フランジ	
5	FA9 - 2112 - 000		2	BUSHING ブッシング	
6	FB2 - 7625 - 000		1	SHAFT, LIFT リフト軸	
7	FB2 - 7652 - 000		1	SUPPORT, SHAFT, FRONT 軸支板 (前)	
8	FB2 - 7740 - 020		2	SHEET, SEPARATION 分離シート	
9	FB2 - 7758 - 000		1	PLATE, JAM STOP, 1 ジャム ストップバ (1)	
10	FB2 - 8465 - 000		2	PULLEY, LIFTING, FRONT リフト プーリ (前)	
11	FB3 - 8508 - 000		1	PAPER QUANTITY INDICATOR UNIT 残量表示ユニット	
12	FB4 - 2026 - 000		1	LEVER, SLIDE スライド レバー	
13	FB4 - 5267 - 000		1	LEVER, SEPARATION RELEASE 分離解除レバー	
14	FB4 - 5268 - 000		1	SUPPORT, SHAFT, REAR 軸支板 (後)	
15	FB4 - 9509 - 000		1	PLATE, SEPARATION 分離板	
16	FB5 - 3365 - 000		1	SPRING, COMPRESSION アッシュク バネ	
17	FB5 - 3370 - 000		1	LEVER, HOOK RELEASE フック解除レバー	
18	FB5 - 5606 - 000		1	HOOK, WIRE, FRONT ワイヤ掛け (前)	
19	FB5 - 5607 - 000		1	HOOK, WIRE, REAR ワイヤ掛け (後)	
20	FB5 - 5608 - 000		1	SUPPORT, FRONT 支え板 (前)	
21	FB5 - 5609 - 000		1	SUPPORT, REAR 支え板 (後)	
22	FB5 - 6980 - 000		1	LEVER, HOOK RELEASE フック解除レバー	
23	FB5 - 6982 - 000		2	LINK, DECK デッキ リンク	
24	FB5 - 6986 - 000		1	LEVER, LEFT COVER 左カバー レバー	
25	FB6 - 2719 - 000		4	PAD 消音パッド	
26	FC1 - 5049 - 000		2	BRACKET スライド コマ	
27	FC1 - 5051 - 000		1	WIRE, LIFTING, FRONT ワイヤ (前)	
28	FC1 - 5052 - 000		1	WIRE, LIFTING, REAR ワイヤ (後)	
29	FC1 - 5055 - 000		1	HOLDER, CABLE, FRONT ワイヤ オサエ (前)	

FIGURE & KEY NO.	PART NUMBER	RANK	QTY	DESCRIPTION	SERIAL NUMBER / REMARKS
303 - 30	FC1 - 5056 - 000		1	HOLDER, CABLE, REAR ワイヤ オサエ (後)	
31	FC1 - 5061 - 000		1	GEAR, 28T 28T ギア	
32	FC1 - 5080 - 000		1	PLATE, LIMIT, WIRE ワイヤ キセイ パン	
33	FC1 - 5081 - 000		1	FLANGE, REAR 1.5K リフト フランジ (後)	
34	FF5 - 8150 - 000		1	LEVER, CAM RELEASE カム解除レバー	
35	FF5 - 8151 - 000		1	HOOK フック	
36	FF5 - 9793 - 000		1	PLATE, LEVER SUPPORT フック解除レバー支板	
37	FF6 - 1014 - 000		1	FRONT COVER, LEFT 前カバー (左)	
37A	FB5 - 3367 - 000		1	PLATE, INDEX, PAPER 残量表示プレート	
38	FF6 - 1054 - 000		1	BUTTON, PUSH プッシュ ボタン	
39	FS2 - 9428 - 000		2	SCREW, M6X6 ネジ	
40	FS4 - 0012 - 000		1	GEAR, 27T 27T ギア	
41	FS4 - 0160 - 000		1	GEAR, 28T 28T ギア	
42	FS4 - 2136 - 000		1	SPRING, COMPRESSION アッシュク バネ	
43	FS5 - 8618 - 000		1	LABEL, "MAXIMUM LOAD" 積載制限ラベル	
44	FS6 - 2983 - 000		1	SPRING, TENSION ヒツパリ バネ	
45	FS6 - 2984 - 000		1	SPRING, COMPRESSION アッシュク バネ	
46	FS7 - 0662 - 000		2	PULLEY, 25T 25T プーリ	
47	FS7 - 5687 - 000		1	SHAFT, RELEASE 解除支軸	
48	XA9 - 0605 - 000		2	SCREW, M4X8 タイト ネジ	
49	XA9 - 0685 - 000		31	SCREW, RS, M4X6 RS タイト ネジ	
50	XA9 - 0721 - 000		10	SCREW, RS, M4X10 RS タイト ネジ	
51	XD9 - 0104 - 000		2	PIN, DOWEL ヘイコウ ピン	
52	XF9 - 0723 - 000		1	BELT, TIMING タイミング ベルト	
53	XG9 - 0439 - 000		2	BEARING, ROLLER ロ-ラ ベアリング	
54	XH9 - 0082 - 000		1	DAMPER, OIL オイル ダンパ	
501	XB1 - 2200 - 409		2	SCREW, MACH., TRUSS HEAD, M2X4 バインド ネジ	
502	XB1 - 2300 - 609		2	SCREW, MACH., TRUSS HEAD, M3X6 バインド ネジ	
503	XB1 - 2400 - 607		3	SCREW, MACH., TRUSS HEAD, M4X6 バインド ネジ	
504	XB1 - 2400 - 609		4	SCREW, MACH., TRUSS HEAD, M4X6 バインド ネジ	

FIGURE & KEY NO.	PART NUMBER	R A N K	Q' T Y	DESCRIPTION	SERIAL NUMBER / REMARKS
303 - 505	XB6 - 2300 - 408		4	SETSCREW,M3X4 ロツカク アナツキ トメネジ	
506	XD1 - 1108 - 239		2	SHIM ヒョウジュン ワッシャ	
507	XD2 - 1100 - 402		2	RING,E E リング	
508	XD2 - 1100 - 502		2	RING,E E リング	
509	XD2 - 1100 - 642		5	RING,E E リング	
510	XD3 - 1200 - 122		1	PIN,SPRING スプリング ピン	

FIGURE 305 CASSETTE HEATER ASSEMBLY

カセット ヒータ部

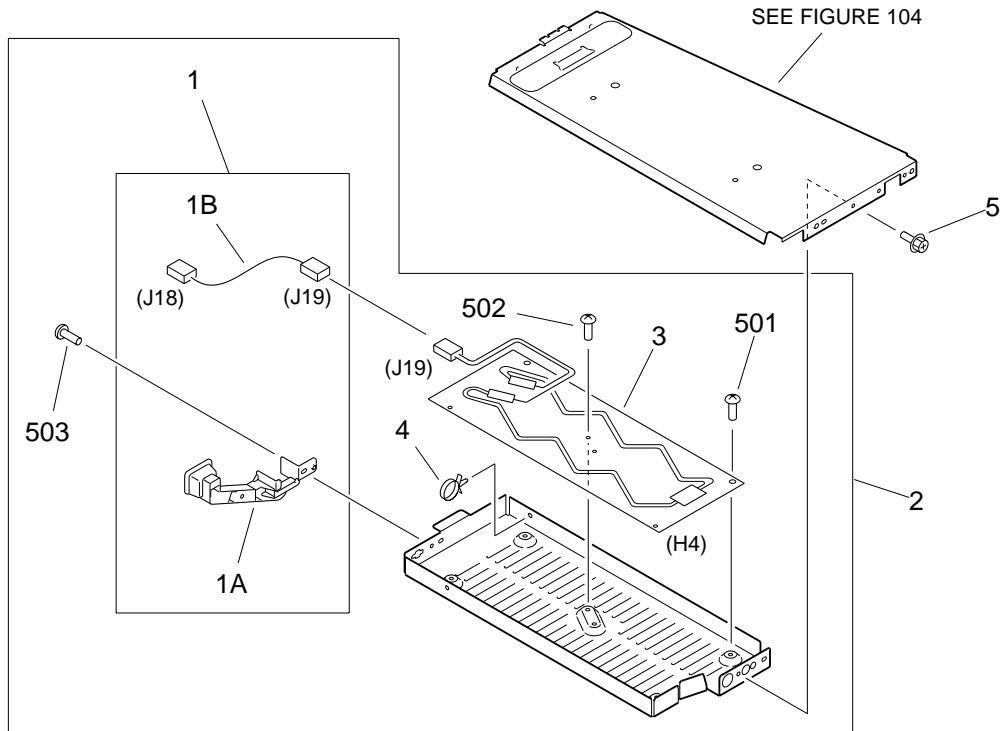
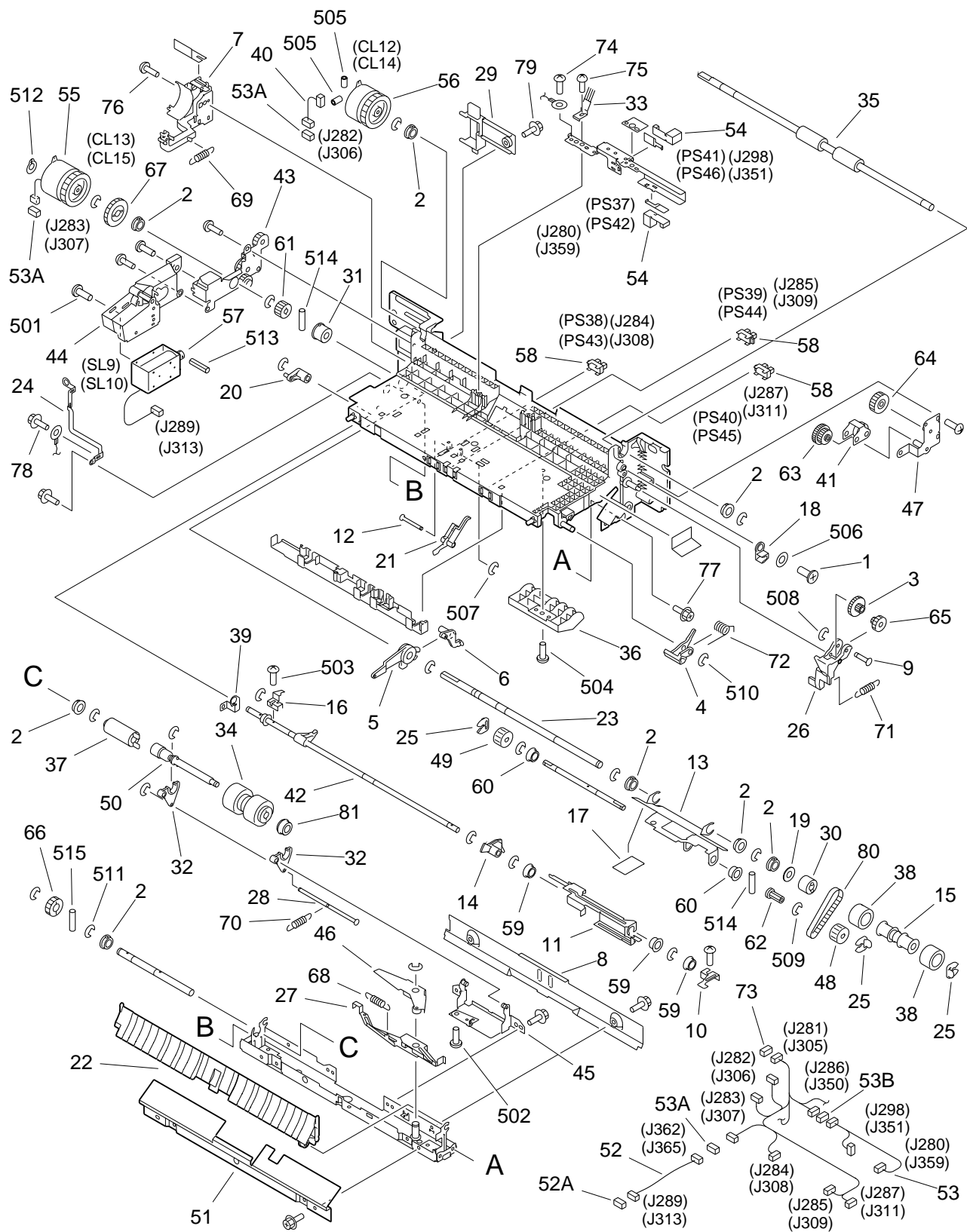

FIGURE & KEY NO.	PART NUMBER	RANK	QTY	DESCRIPTION	SERIAL NUMBER / REMARKS
305 -	NPN		RF	CASSETTE HEATER ASSEMBLY カセット ヒータ部	200V ACCESSORY 220/240V
1	FG2 - 9195 - 000		1	CORD GUIDE ASSEMBLY コード ガイド部	
1A	FB3 - 9910 - 000		1	GUIDE, HEATER CABLE ヒータ ガイド	
1B	FG5 - 9419 - 000		1	CABLE, HEATER ヒータ中継束線	J18,19
2	FG2 - 9812 - 000	N	1	HEATER ASSEMBLY ヒータ ユニット	
3	FH7 - 4585 - 000		1	HEATER, CASSETTE カセット ヒータ	H4 J19
4	WT2 - 5041 - 000		1	CLAMP, CABLE ケーブル クランプ	
5	XA9 - 0628 - 000		2	SCREW,RS,M4X8 RS タイト ネジ	
501	XB1 - 2400 - 409		4	SCREW,MACH.,TRUSS HEAD,M4X4 バインド ネジ	
502	XB6 - 7300 - 409		1	SCREW,TP,M3X4 TP ネジ	
503	XB6 - 7400 - 609		1	SCREW,TP,M4X6 TP ネジ	

FIGURE 311 CASSETTE PICK-UP ASSEMBLY

カセット給紙部



NOTE: This assembly does not include the parts shown with key No. 29, 73, and 79.
 注：このユニットにKey No. 29、73、79の部品は含まれません。

FIGURE & KEY NO.	PART NUMBER	R A N K	Q' T Y	DESCRIPTION	SERIAL NUMBER / REMARKS
311 -	FG6 - 8017 - 000		2	CASSETTE PICK-UP ASSEMBLY カセット給紙部	
1	FA6 - 6457 - 000		1	SCREW,M3X5 ネジ	
2	FA9 - 2112 - 000		8	BUSHING ブッシング	
3	FA9 - 3827 - 000		1	GEAR, 17T/58T 17T / 58T ギア	
4	FB2 - 7593 - 000		1	CAM カム	
5	FB2 - 7605 - 000		1	LINK, UP, 1 アップ リンク (1)	
6	FB2 - 7606 - 000		1	LINK, UP, 2 アップ リンク (2)	
7	FB2 - 7607 - 020		1	PLATE, LIMIT, CLUTCH クラッチ キセイ パン	
8	FB2 - 7616 - 000		1	GUIDE, FEED ハンソウ ガイド	
9	FB2 - 7620 - 000		1	SHAFT, LIFT, UPPER リфта ヨウドウ ジク (ウエ)	
10	FB2 - 7624 - 000		1	PLATE, PICK-UP, FRONT ピックアップ板 (前)	
11	FB2 - 7631 - 020		1	PLATE, RELEASE シメン フラッグ カイジョ パン	
12	FB2 - 7633 - 000		1	SHAFT, SENSOR センサ シジク	
13	FB2 - 7641 - 000		1	PLATE, PICK-UP ピックアップ板	
14	FB2 - 7642 - 000		1	ARM, PAPER カミ アリ ア - ム	
15	FB2 - 7696 - 000		1	COLLAR, PAPER FEED ROLLER ハンソウ ローラ コロ	
16	FB2 - 8266 - 000		1	PLATE, PICK-UP, REAR ピックアップ パン (ウシロ)	
17	FB2 - 8410 - 000		1	SHEET, PICK-UP ピックアップ シ - ト	
18	FB2 - 8436 - 000		1	BUSHING ブッシング	
19	FB2 - 8512 - 000		1	SPACER スペーサ	
20	FB3 - 8333 - 000		1	CAM, PICK-UP RELEASE 給紙解除カム	
21	FB4 - 1202 - 000		1	FLAG, PAPER 紙面フラッグ	
22	FB4 - 1982 - 000		1	GUIDE, OPEN/CLOSE 開閉ガイド	
23	FB4 - 1989 - 000		1	SHAFT, PAPER FEED ROLLER 搬送ローラ軸	
24	FB4 - 2004 - 000		1	PLATE, GROUNDING アース板	
25	FB4 - 2007 - 000		3	RING, RETAINING 止め輪	
26	FB4 - 3700 - 000		1	LEVER, LIFTER RELEASE リфта解除レバー	
27	FB4 - 6214 - 000		1	LEVER, SEPARATION RELEASE, 2 分離解除レバー (2)	
28	FB4 - 6227 - 000		1	SHAFT, COUNTER カウンタ軸	
29	FB4 - 7835 - 000		1	COVER, CONNECTOR, PICK-UP コネクタ カバー (給紙)	SEE NOTE

FIGURE & KEY NO.	PART NUMBER	RANK	QTY	DESCRIPTION	SERIAL NUMBER / REMARKS
311 - 30	FB4 - 9029 - 000		1	CLUTCH, ONE-WAY ワンウェイ クラッチ	
31	FB4 - 9043 - 000		1	CLUTCH, ONE-WAY ワンウェイ クラッチ	
32	FB5 - 2063 - 000		2	ARM, SEPARATION ROLLER 分離ローラ アーム	
33	FB5 - 5621 - 000		1	ELIMINATOR, STATIC CHARGE 除電針	
34	FB5 - 6586 - 000		1	ROLLER, SEPARATION 分離ローラ	
35	FB5 - 7013 - 000		1	ROLLER, FEED 搬送ローラ	
36	FB6 - 0513 - 000		1	GUIDE, UPPER ガイド パン (ウエ)	
37	FB6 - 0519 - 000		1	TORQUE, LIMITER トルク リミッタ	
38	FB6 - 0615 - 000		2	ROLLER, FEED 搬送ローラ	
39	FB6 - 2377 - 000		1	PLATE, PICK-UP GROUNDING 給紙アース板	
40	FF3 - 4190 - 000		1	CABLE, CLUTCH クラッチ束線	J282,306
41	FF5 - 3063 - 030		1	PLATE, LIFT リフタ ヨウドウ パン	
42	FF5 - 3220 - 000		1	SHAFT, PAPER PICK-UP 給紙軸	
43	FF5 - 5894 - 000		1	PLATE, SUPPORT, LOWER 入力支持板 (下)	
44	FF5 - 5895 - 000		1	MOUNT, PICK-UP SOLENOID 給紙ソレノイド台	
45	FF5 - 6889 - 000		1	MOUNT, SEPARATION ROLLER 分離ローラ支台	
46	FF5 - 6904 - 000		1	LEVER, SEPARATION RELEASE, 1 分離解除レバー (1)	
47	FF5 - 6905 - 000		1	SUPPORT, LIFTER GEAR リフタ ギア支持板	
48	FF5 - 7829 - 000		1	ROLLER, PICK-UP 給紙ローラ	FRONT
49	FF5 - 7830 - 000		1	ROLLER, PICK-UP 給紙ローラ	REAR
50	FF5 - 9784 - 000		1	SHAFT, SEPARATION ROLLER 分離ローラ軸	
51	FF6 - 1533 - 000		1	GUIDE, PICK-UP INLET, RIGHT 給紙入口ガイド (右)	
52	FG6 - 2335 - 000		1	CABLE, SOLENOID CONNECTING ソレノイド中継束線	J289,362 J313,365
52 A	VS1 - 5057 - 002		1	CONNECTOR, SNAP TIGHT チュウケイ コネクタ	J289,313
53	FG6 - 8590 - 000		1	CABLE, PAPER PICK-UP カセット給紙束線	J280-287,298,362 J305-309,311,350,351
53 A	VS1 - 5057 - 002		1	CONNECTOR, SNAP TIGHT チュウケイ コネクタ	J359,365 J282,283,362 J306,307,365
53 B	VS1 - 5057 - 008		1	CONNECTOR, SNAP TIGHT チュウケイ コネクタ	J286,350
54	FG6 - 8605 - 000		2	OPTICAL SENSOR PCB ASSEMBLY 光学センサ回路基板	PS37,41,42,46 J280,298,359,351
55	FH6 - 5014 - 000		1	CLUTCH, ELECTROMAGNETIC 電磁クラッチ	CL13 J283 CL15 J307

FIGURE & KEY NO.	PART NUMBER	RANK	QTY	DESCRIPTION	SERIAL NUMBER / REMARKS
311 - 56	FH6 - 5043 - 000		1	CLUTCH, ELECTROMAGNETIC 電磁クラッチ	CL12,14
57	FH7 - 5702 - 000		1	SOLENOID ソレノイド	SL9 J289 SL10 J313
58	FH7 - 7462 - 000		3	PHOTO-INTERRUPTER フォトインタラプタ	PS38-40 J284,285,287 PS43-45 J308,309,311
59	FS1 - 1512 - 000		4	BUSHING ブッシング	
60	FS1 - 1569 - 000		2	BUSHING ブッシング	
61	FS5 - 0338 - 000		1	GEAR, 16T 16T ギア	
62	FS5 - 3333 - 000		1	PULLEY, 16T 16T プーリ	
63	FS6 - 0048 - 000		1	GEAR, 16T/46T 16T / 46T ギア	
64	FS6 - 0049 - 000		1	GEAR, 48T 48T ギア	
65	FS6 - 0051 - 000		1	GEAR, 17T/20T 17T / 20T ギア	
66	FS6 - 0053 - 020		1	GEAR, 20T 20T ギア	
67	FS6 - 0056 - 000		1	GEAR, 32T 32T ギア	
68	FS6 - 2668 - 000		1	SPRING, TENSION ヒツパリ バネ	
69	FS6 - 2670 - 000		1	SPRING, TENSION ヒツパリ バネ	
70	FS6 - 2678 - 000		1	SPRING, TENSION ヒツパリ バネ	
71	FS6 - 2742 - 000		1	SPRING, TENSION ヒツパリ バネ	
72	FS6 - 2996 - 000		1	SPRING, TORSION ネジリ バネ	
73	VS1 - 6319 - 026		2	CONNECTOR, SNAP TIGHT チュウケイ コネクタ	SEE NOTE J281,305
74	XA9 - 0265 - 000		2	SCREW,W/WASHER,TRUSS HEAD ザツキ バインド ネジ	
75	XA9 - 0591 - 000		2	SCREW,M3X8 タイト ネジ	
76	XA9 - 0605 - 000		4	SCREW,M4X8 タイト ネジ	
77	XA9 - 0628 - 000		9	SCREW,RS,M4X8 RS タイト ネジ	
78	XA9 - 0633 - 000		1	SCREW,RS,M4X8 RS タイト ネジ	
79	XA9 - 0643 - 000		1	SCREW,RS,M4X10 RS タイト ネジ	SEE NOTE
80	XF9 - 0525 - 000		1	BELT, TIMING, 59T タイミング ベルト	
81	XG9 - 0407 - 000		1	BEARING, BALL, UGF106P12ZZD4ML ボール ベアリング	
501	XB1 - 2300 - 407		2	SCREW,MACH.,TRUSS HEAD,M3X4 バインド ネジ	
502	XB1 - 2300 - 409		1	SCREW,MACH.,TRUSS HEAD,M3X4 バインド ネジ	
503	XB1 - 2300 - 609		2	SCREW,MACH.,TRUSS HEAD,M3X6 バインド ネジ	
504	XB1 - 2400 - 609		4	SCREW,MACH.,TRUSS HEAD,M4X6 バインド ネジ	

FIGURE & KEY NO.	PART NUMBER	R A N K	Q' T Y	DESCRIPTION	SERIAL NUMBER / REMARKS
311 - 505	XB6 - 2400 - 509		2	SETSCREW,M4X5 ロツカク アナツキ トメネジ	
506	XD1 - 1104 - 132		1	SHIM ヒョウジュン ワッシャ	
507	XD2 - 1100 - 242		2	RING,E E リング	
508	XD2 - 1100 - 322		1	RING,E E リング	
509	XD2 - 1100 - 372		1	RING,E E リング	
510	XD2 - 1100 - 502		7	RING,E E リング	
511	XD2 - 1100 - 642		11	RING,E E リング	
512	XD2 - 2100 - 802		1	RING,GRIP グリップ リング	
513	XD3 - 0300 - 082		1	PIN,SPRING スプリング ピン	
514	XD3 - 2200 - 102		2	PIN,DOWEL ヘイコウ ピン	
515	XD3 - 2200 - 122		1	PIN,DOWEL ヘイコウ ピン	

FIGURE 312 FRONT DECK (RIGHT) PICK-UP ASSEMBLY

フロントデッキ(右)給紙部

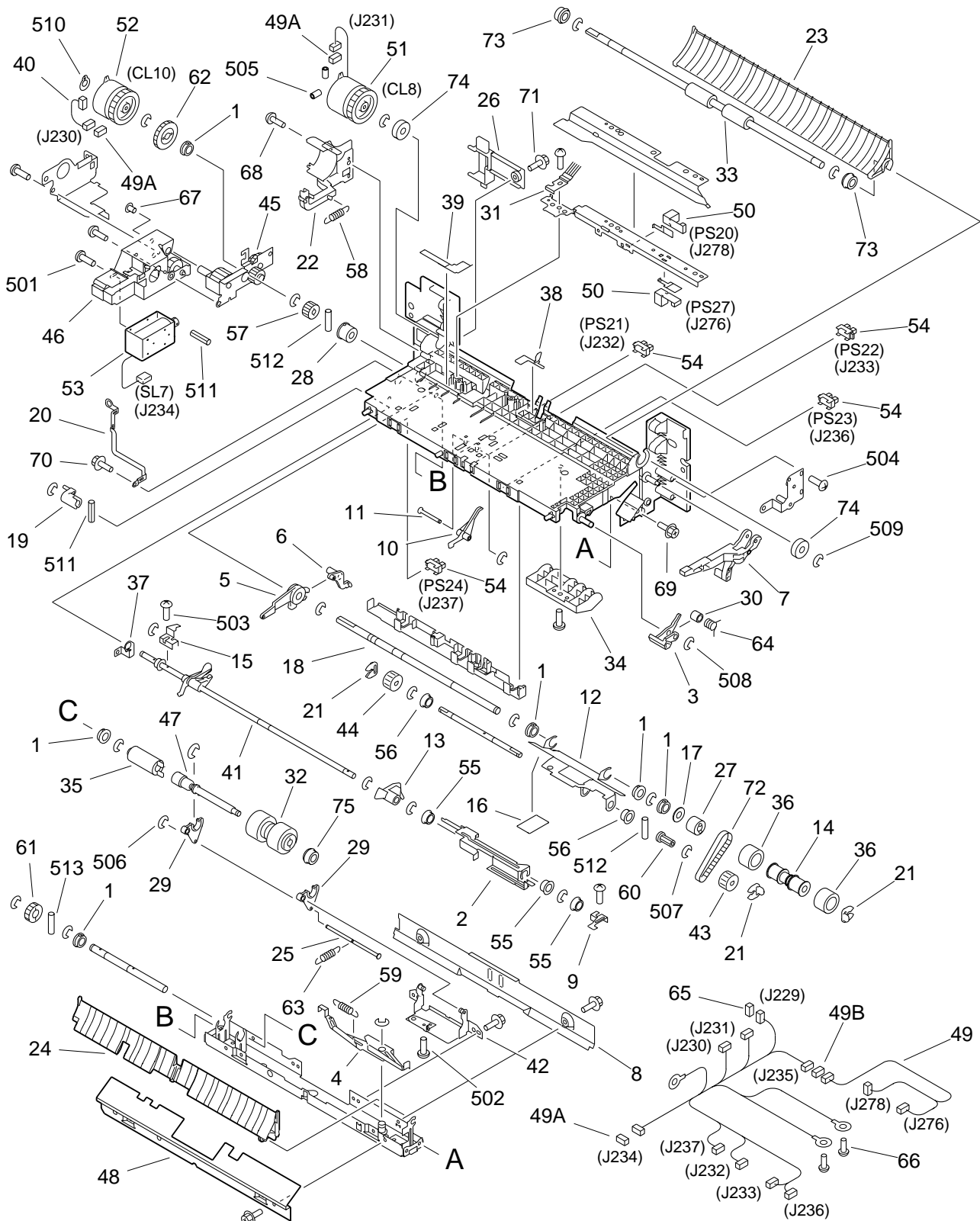

NOTE: This assembly does not include the parts shown with key No. 26, 65 and 71.
 注: このユニットにKey No. 26, 65, 71の部品は含まれません。

FIGURE & KEY NO.	PART NUMBER	RANK	QTY	DESCRIPTION	SERIAL NUMBER / REMARKS
312 -	FG6 - 8018 - 000		1	FRONT DECK RIGHT PICK-UP ASS'Y フロント デッキ右給紙部	
1	FA9 - 2112 - 000		6	BUSHING ブッシング	
2	FA9 - 3691 - 000		1	PLATE, PAPER FLAG RELEASE 紙面フラグ解除板	
3	FB2 - 7593 - 000		1	CAM カム	
4	FB2 - 7603 - 000		1	LEVER, RELEASE カイジョ レバ -	
5	FB2 - 7605 - 000		1	LINK, UP, 1 アップ リンク (1)	
6	FB2 - 7606 - 000		1	LINK, UP, 2 アップ リンク (2)	
7	FB2 - 7614 - 000		1	LEVER, RELEASE リフタ カイジョ レバ -	
8	FB2 - 7616 - 000		1	GUIDE, FEED ハンソウ ガイド	
9	FB2 - 7624 - 000		1	PLATE, PICK-UP, FRONT ピックアップ板 (前)	
10	FB2 - 7630 - 000		1	FLAG, PAPER 紙面フラッグ	
11	FB2 - 7633 - 000		1	SHAFT, SENSOR センサ シジク	
12	FB2 - 7641 - 000		1	PLATE, PICK-UP ピックアップ板	
13	FB2 - 7642 - 000		1	ARM, PAPER カミ アリ ア - ム	
14	FB2 - 7696 - 000		1	COLLAR, PAPER FEED ROLLER ハンソウ ローラ コロ	
15	FB2 - 8266 - 000		1	PLATE, PICK-UP, REAR ピックアップ パン (ウシ口)	
16	FB2 - 8410 - 000		1	SHEET, PICK-UP ピックアップ シ - ト	
17	FB2 - 8512 - 000		1	SPACER スペーサ	
18	FB4 - 1989 - 000		1	SHAFT, PAPER FEED ROLLER 搬送ローラ軸	
19	FB4 - 2000 - 000		1	CAM, PICK-UP RELEASE, REAR 給紙解除カム (後)	
20	FB4 - 2004 - 000		1	PLATE, GROUNDING アース板	
21	FB4 - 2007 - 000		3	RING, RETAINING 止め輪	
22	FB4 - 2009 - 000		1	PLATE, CLUTCH LIMIT, RIGHT クラッチ規制板 (右)	
23	FB4 - 2010 - 000		1	GUIDE, JOINT ジョイント ガイド	
24	FB4 - 2012 - 000		1	GUIDE, OPEN/CLOSE, RIGHT 開閉ガイド (右)	
25	FB4 - 6227 - 000		1	SHAFT, COUNTER カウンタ軸	
26	FB4 - 7835 - 000		1	COVER, CONNECTOR, PICK-UP コネクタ カバー (給紙)	SEE NOTE
27	FB4 - 9029 - 000		1	CLUTCH, ONE-WAY ワンウェイ クラッチ	
28	FB4 - 9043 - 000		1	CLUTCH, ONE-WAY ワンウェイ クラッチ	
29	FB5 - 2063 - 000		2	ARM, SEPARATION ROLLER 分離ローラ アーム	

FIGURE & KEY NO.	PART NUMBER	RANK	QTY	DESCRIPTION	SERIAL NUMBER / REMARKS
312 - 30	FB5 - 4339 - 000		1	SPACER, CAM カム スペーサ	
31	FB5 - 5620 - 000		1	ELIMINATOR, STATIC CHARGE 除電針	
32	FB5 - 6586 - 000		1	ROLLER, SEPARATION 分離ローラ	
33	FB5 - 7013 - 000		1	ROLLER, FEED 搬送ローラ	
34	FB6 - 0513 - 000		1	GUIDE, UPPER ガイド パン (ウエ)	
35	FB6 - 0519 - 000		1	TORQUE, LIMITER トルク リミッタ	
36	FB6 - 0615 - 000		2	ROLLER, FEED 搬送ローラ	
37	FB6 - 2377 - 000		1	PLATE, PICK-UP GROUNDING 給紙アース板	
38	FB6 - 4057 - 000		1	PARTITION, RIGHT EXTRACTION 右引抜き仕切板	
39	FB6 - 4059 - 000		1	COVER, RIGHT LOWER, 2 右下カバー (2)	
40	FF3 - 4190 - 000		1	CABLE, CLUTCH クラッチ束線	J230
41	FF5 - 3228 - 000		1	SHAFT, PICK-UP, UPPER ピックアップ軸 (上)	
42	FF5 - 6889 - 000		1	MOUNT, SEPARATION ROLLER 分離ローラ支台	
43	FF5 - 7829 - 000		1	ROLLER, PICK-UP 給紙ローラ	FRONT
44	FF5 - 7830 - 000		1	ROLLER, PICK-UP 給紙ローラ	REAR
45	FF5 - 7832 - 000		1	SUPPORT, PLATE, RIGHT 入力支持板 (右)	
46	FF5 - 7833 - 000		1	MOUNT, SOLENOID, RIGHT ソレノイド台 (右)	
47	FF5 - 9784 - 000		1	SHAFT, SEPARATION ROLLER 分離ローラ軸	
48	FF6 - 1534 - 000		1	GUIDE, PICK-UP INLET, RIGHT 給紙入口ガイド (右)	
49	FG6 - 8591 - 000		1	CABLE, RIGHT DECK 右デッキ給紙束線	J229-237,276,278
49A	VS1 - 5057 - 002		3	CONNECTOR, SNAP TIGHT チュウケイ コネクタ	J230,231,234
49B	VS1 - 5057 - 008		1	CONNECTOR, SNAP TIGHT チュウケイ コネクタ	J235
50	FG6 - 8605 - 000		2	OPTICAL SENSOR PCB ASSEMBLY 光学センサ回路基板	PS20,27 J278,276
51	FH6 - 5014 - 000		1	CLUTCH, ELECTROMAGNETIC 電磁クラッチ	CL8 J231
52	FH6 - 5043 - 000		1	CLUTCH, ELECTROMAGNETIC 電磁クラッチ	CL10
53	FH7 - 5827 - 000		1	SOLENOID ソレノイド	SL7 J234
54	FH7 - 7462 - 000		4	PHOTO-INTERRUPTER フォトインタラプタ	PS21-24 J232,233,236,237
55	FS1 - 1512 - 000		3	BUSHING ブッシング	
56	FS1 - 1569 - 000		2	BUSHING ブッシング	
57	FS5 - 0338 - 000		1	GEAR, 16T 16T ギア	

FIGURE & KEY NO.	PART NUMBER	R A N K	Q' T Y	DESCRIPTION	SERIAL NUMBER / REMARKS
312 - 58	FS5 - 2911 - 000		1	SPRING, TENSION ヒツパリ バネ	
59	FS5 - 2914 - 000		1	SPRING, TENSION ヒツパリ バネ	
60	FS5 - 3333 - 000		1	PULLEY, 16T 16T プーリ	
61	FS6 - 0053 - 020		1	GEAR, 20T 20T ギア	
62	FS6 - 0056 - 000		1	GEAR, 32T 32T ギア	
63	FS6 - 2678 - 000		1	SPRING, TENSION ヒツパリ バネ	
64	FS6 - 2997 - 000		1	SPRING, TORSION ネジリ バネ	
65	VS1 - 6319 - 028		1	CONNECTOR, SNAP TIGHT チュウケイ コネクタ	SEE NOTE J229
66	XA9 - 0265 - 000		2	SCREW, W/WASHER, TRUSS HEAD ザツキ バインド ネジ	
67	XA9 - 0271 - 000		1	SCREW, M4X6 ネジ	
68	XA9 - 0605 - 000		6	SCREW, M4X8 タイト ネジ	
69	XA9 - 0628 - 000		9	SCREW, RS, M4X8 RS タイト ネジ	
70	XA9 - 0633 - 000		1	SCREW, RS, M4X8 RS タイト ネジ	
71	XA9 - 0643 - 000		1	SCREW, RS, M4X10 RS タイト ネジ	SEE NOTE
72	XF9 - 0525 - 000		1	BELT, TIMING, 59T タイミング ベルト	
73	XG9 - 0211 - 000		2	BALL BEARING, MF128ZZ1MC3D4M ボール ベアリング	
74	XG9 - 0250 - 000		2	BEARING, BALL ボール ベアリング	
75	XG9 - 0407 - 000		2	BEARING, BALL, UGF106P12ZZD4ML ボール ベアリング	
501	XB1 - 2300 - 407		2	SCREW, MACH., TRUSS HEAD, M3X4 バインド ネジ	
502	XB1 - 2300 - 409		1	SCREW, MACH., TRUSS HEAD, M3X4 バインド ネジ	
503	XB1 - 2300 - 609		2	SCREW, MACH., TRUSS HEAD, M3X6 バインド ネジ	
504	XB1 - 2400 - 609		4	SCREW, MACH., TRUSS HEAD, M4X6 バインド ネジ	
505	XB6 - 2400 - 509		2	SETSCREW, M4X5 ロツカク アナツキ トメネジ	
506	XD2 - 1100 - 242		2	RING, E E リング	
507	XD2 - 1100 - 372		1	RING, E E リング	
508	XD2 - 1100 - 502		9	RING, E E リング	
509	XD2 - 1100 - 642		13	RING, E E リング	
510	XD2 - 2100 - 802		1	RING, GRIP グリップ リング	
511	XD3 - 0300 - 082		1	PIN, SPRING スプリング ピン	
512	XD3 - 2200 - 102		2	PIN, DOWEL ヘイコウ ピン	

FIGURE & KEY NO.	PART NUMBER	R A N K	Q' T Y	DESCRIPTION	SERIAL NUMBER / REMARKS
312 - 513	XD3 - 2200 - 122		1	PIN,DOWEL ヘイコウ ピン	

FIGURE 313 FRONT DECK (LEFT) PICK-UP ASSEMBLY

フロントデッキ(左)給紙部

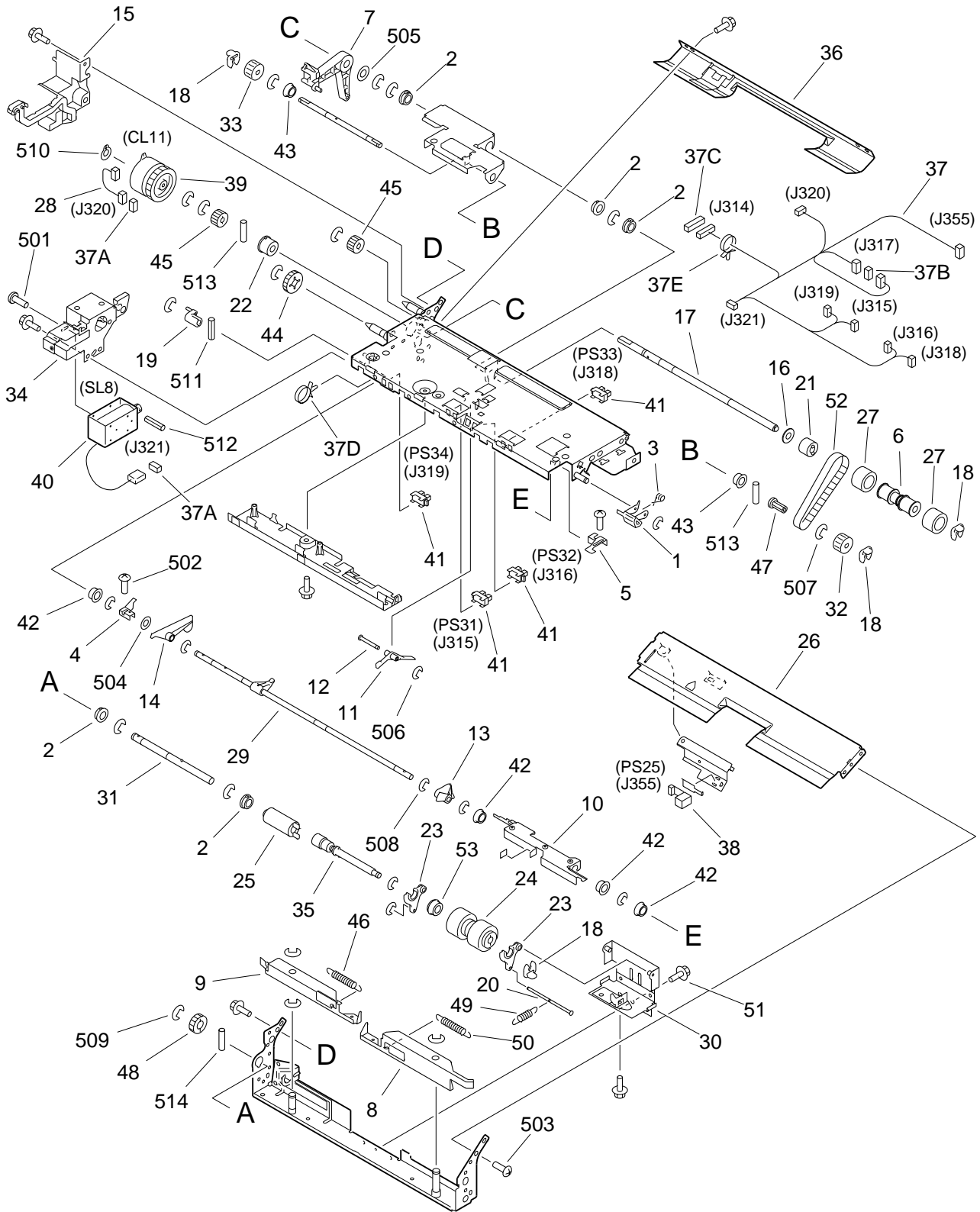
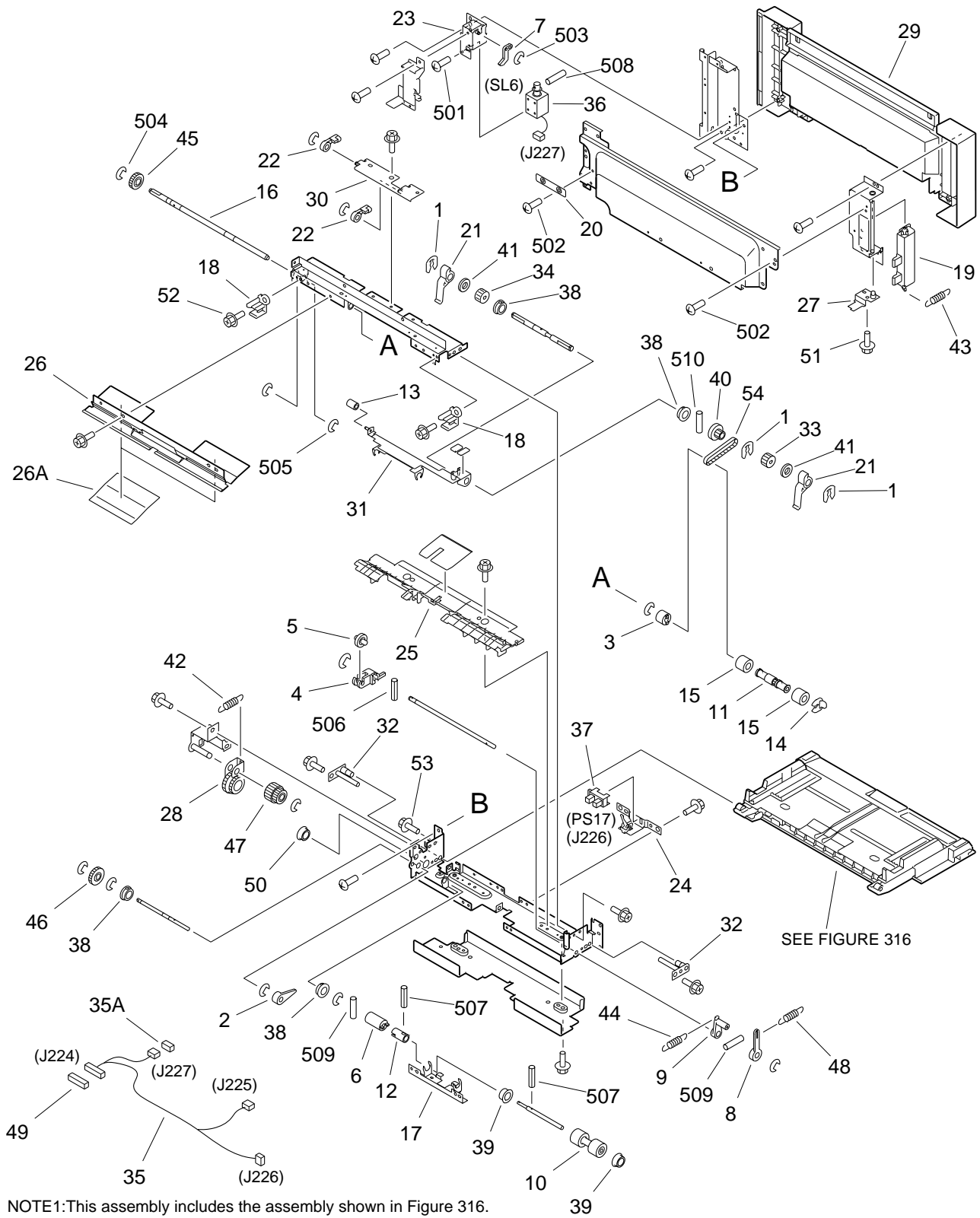

FIGURE & KEY NO.	PART NUMBER	RANK	QTY	DESCRIPTION	SERIAL NUMBER / REMARKS
313 -	FG6 - 8019 - 000		1	FRONT DECK LEFT PICK-UP ASS'Y フロント デッキ左給紙部	
1	FA5 - 2872 - 000		1	ARM, RELEASE, ROLLER, FRONT 給紙ローラ解除アーム (前)	
2	FA9 - 2112 - 000		5	BUSHING ブッシング	
3	FB1 - 7070 - 000		1	SPRING, TORSION ネジリ バネ	
4	FB2 - 7623 - 000		1	PLATE, PICK-UP, REAR ピックアップ板 (後)	
5	FB2 - 7624 - 000		1	PLATE, PICK-UP, FRONT ピックアップ板 (前)	
6	FB2 - 7696 - 000		1	COLLAR, PAPER FEED ROLLER ハンソウ ローラ コロ	
7	FB2 - 7715 - 020		1	LINK, RELEASE 解除リンク	
8	FB2 - 7716 - 000		1	PLATE, RELEASE 分離解除リンク板	
9	FB2 - 7717 - 000		1	PLATE, RELEASE 分離解除リンク板	
10	FB2 - 7718 - 000		1	PLATE, RELEASE LEVER 紙面レバー解除板	
11	FB2 - 7720 - 000		1	LEVER, PAPER 紙面レバー	
12	FB2 - 7721 - 000		1	SHAFT, PAPER LEVER 紙面レバー軸	
13	FB2 - 7722 - 000		1	LEVER, PAPER SENSOR 紙無しレバー	
14	FB2 - 7723 - 000		1	LEVER, LIMITER リミッタ レバー	
15	FB2 - 7724 - 000		1	GUIDE, CABLE ソクセン ガイド	
16	FB2 - 8512 - 000		1	SPACER スペーサ	
17	FB4 - 1990 - 000		1	SHAFT, FEED ROLLER 搬送ローラ軸	
18	FB4 - 2007 - 000		3	RING, RETAINING 止め輪	
19	FB4 - 2031 - 000		1	CAM, PICK-UP RELEASE, REAR 給紙解除カム (後)	
20	FB4 - 6227 - 000		1	SHAFT, COUNTER カウンタ軸	
21	FB4 - 9029 - 000		1	CLUTCH, ONE-WAY ワンウェイ クラッチ	
22	FB4 - 9043 - 000		1	CLUTCH, ONE-WAY ワンウェイ クラッチ	
23	FB5 - 2063 - 000		2	ARM, SEPARATION ROLLER 分離ローラ アーム	
24	FB5 - 6586 - 000		1	ROLLER, SEPARATION 分離ローラ	
25	FB6 - 0519 - 000		1	TORQUE, LIMITER トルク リミッタ	
26	FB6 - 0524 - 000		1	GUIDE, PICK-UP, LOWER 給紙ガイド (下)	
27	FB6 - 0615 - 000		2	ROLLER, FEED 搬送ローラ	
28	FF3 - 4190 - 000		1	CABLE, CLUTCH クラッチ束線	J320
29	FF5 - 3221 - 000		1	SHAFT, PICK-UP, LEFT ピックアップ軸 (左)	

FIGURE & KEY NO.	PART NUMBER	RANK	QTY	DESCRIPTION	SERIAL NUMBER / REMARKS
313 - 30	FF5 - 6890 - 000		1	MOUNT, SEPARATION ROLLER 分離ローラ支台	
31	FF5 - 7540 - 000		1	SHAFT, SEPARATION DRIVE 分離駆動軸	
32	FF5 - 7829 - 000		1	ROLLER, PICK-UP 給紙ローラ	
33	FF5 - 7830 - 000		1	ROLLER, PICK-UP 給紙ローラ	
34	FF5 - 7840 - 000		1	MOUNT, SOLENOID, LEFT ソレノイド台 (左)	
35	FF5 - 9784 - 000		1	SHAFT, SEPARATION ROLLER 分離ローラ軸	
36	FF6 - 1535 - 000		1	GUIDE, PICK-UP, UPPER 給紙ガイド (上)	
37	FG6 - 8592 - 000		1	CABLE, LEFT DECK 左デッキ給紙束線	J314-321,355
37A	VS1 - 5057 - 002		2	CONNECTOR, SNAP TIGHT チュウケイ コネクタ	J320,321
37B	VS1 - 5057 - 004		1	CONNECTOR, SNAP TIGHT チュウケイ コネクタ	J317
37C	VS1 - 6319 - 020		1	CONNECTOR, SNAP TIGHT チュウケイ コネクタ	J314
37D	WT2 - 5178 - 000		6	CLIP, CABLE ロッキング ワイヤ サドル	
37E	WT2 - 5565 - 000		1	CLAMP, CABLE ソクセン オサエ	
38	FG6 - 8605 - 000		1	OPTICAL SENSOR PCB ASSEMBLY 光学センサ回路基板	PS25 J355
39	FH6 - 5043 - 000		1	CLUTCH, ELECTROMAGNETIC 電磁クラッチ	CL11
40	FH7 - 5827 - 000		1	SOLENOID ソレノイド	SL8 J321
41	FH7 - 7462 - 000		4	PHOTO-INTERRUPTER フォトインタラプタ	PS31-34 J315,316,318,319
42	FS1 - 1512 - 000		4	BUSHING ブッシング	
43	FS1 - 1569 - 000		2	BUSHING ブッシング	
44	FS2 - 0544 - 000		1	GEAR, 24T 24T ギア	
45	FS5 - 0338 - 000		2	GEAR, 16T 16T ギア	
46	FS5 - 2919 - 000		1	SPRING, TENSION ヒツバリ バネ	
47	FS5 - 3333 - 000		1	PULLEY, 16T 16T プーリ	
48	FS6 - 0053 - 020		1	GEAR, 20T 20T ギア	
49	FS6 - 2678 - 000		1	SPRING, TENSION ヒツバリ バネ	
50	FS7 - 2533 - 000		1	SPRING, TENSION ヒツバリ バネ	
51	XA9 - 0628 - 000		11	SCREW,RS,M4X8 RS タイト ネジ	
52	XF9 - 0525 - 000		1	BELT, TIMING, 59T タイミング ベルト	
53	XG9 - 0407 - 000		1	BEARING, BALL, UGF106P12ZZD4ML ボール ベアリング	
501	XB1 - 2300 - 407		2	SCREW,MACH.,TRUSS HEAD,M3X4 バインド ネジ	

FIGURE & KEY NO.	PART NUMBER	R A N K	Q' T Y	DESCRIPTION	SERIAL NUMBER / REMARKS
313 - 502	XB1 - 2300 - 609		3	SCREW,MACH.,TRUSS HEAD,M3X6 バインド ネジ	
503	XB1 - 2400 - 609		2	SCREW,MACH.,TRUSS HEAD,M4X6 バインド ネジ	
504	XD1 - 1108 - 223		1	SHIM ヒョウジュン ワッシャ	
505	XD1 - 1108 - 226		1	SHIM ヒョウジュン ワッシャ	
506	XD2 - 1100 - 242		2	RING,E E リング	
507	XD2 - 1100 - 322		1	RING,E E リング	
508	XD2 - 1100 - 502		9	RING,E E リング	
509	XD2 - 1100 - 642		13	RING,E E リング	
510	XD2 - 2100 - 802		1	RING,GRIP グリップ リング	
511	XD3 - 1200 - 102		1	PIN,SPRING スプリング ピン	
512	XD3 - 1300 - 102		1	PIN,SPRING スプリング ピン	
513	XD3 - 2200 - 102		2	PIN,DOWEL ヘイコウ ピン	
514	XD3 - 2200 - 122		1	PIN,DOWEL ヘイコウ ピン	

FIGURE 315 MULTI FEED ASSEMBLY マルチ手差し部



NOTE1: This assembly includes the assembly shown in Figure 316.
 NOTE2: This assembly does not include the part shown with key No. 49.
 注1: このユニットはFigure316のユニットを含みます。
 注2: このユニットにKey No. 49の部品は含まれません。

FIGURE & KEY NO.	PART NUMBER	RANK	QTY	DESCRIPTION	SERIAL NUMBER / REMARKS
315 -	FG6 - 8736 - 000		1	MULTI FEED ASSEMBLY マルチ手差し部	SEE NOTE 1
1	FA3 - 8727 - 000		3	RING, RETAINING 止め輪	
2	FA5 - 4266 - 000		1	ARM アーム	
3	FA6 - 7728 - 000		1	COLLAR, FEEDER ROLLER ハンソウ ロール カラ	
4	FA6 - 7737 - 000		1	ARM, RETARD リタード アーム	
5	FA6 - 8071 - 000		1	ROLLER コロ	
6	FA9 - 3669 - 000		1	TORQUE LIMITER トルク リミッタ	
7	FB2 - 7515 - 020		1	ARM, PICK-UP ピック アップ アーム	
8	FB2 - 7537 - 000		1	LEVER, PRESSURE カアツ レバ	
9	FB2 - 7542 - 000		1	LEVER, RELEASE アツ カイジョ レバ	
10	FB2 - 7545 - 000		1	ROLLER, SPONGE スポンジ ロール	
11	FB2 - 7558 - 000		1	COLLAR, FEED ROLLER 搬送ロール コロ	
12	FB2 - 8227 - 000		1	COUPLING カップリング	
13	FB2 - 8384 - 000		1	ROLLER, PICK-UP ピックアップ コロ	
14	FB4 - 2007 - 000		1	RING, RETAINING 止め輪	
15	FB4 - 2035 - 000		2	ROLLER, FEED ROLLER 搬送ロール	
16	FB4 - 3747 - 000		1	SHAFT, FEEDER ROLLER 搬送ロール軸	
17	FB4 - 3750 - 000		1	MOUNT, SEPARATION ROLLER 分離ロール台	
18	FB4 - 3759 - 000		2	GUIDE, POSITIONING 位置決めガイド	
19	FB4 - 3772 - 000		1	HANDLE, MULTI FEED DOOR マルチ扉ハンドル	
20	FB4 - 7840 - 000		1	TAPE, SUPPORT 支えテープ	
21	FB5 - 2837 - 000		2	SHUTTER シャッター	
22	FB5 - 2838 - 000		2	BLOCK, SHUTTER STOP シャッター ストップ	
23	FF5 - 2939 - 000		1	PLATE, SOLENOID ソレノイド パン	
24	FF5 - 2943 - 000		1	MOUNT, SENSOR センサ ダイ	
25	FF5 - 3135 - 020		1	PLATE, GUIDE PAPER マルチ ナカایت	
26	FF5 - 7673 - 000		1	GUIDE, UPPER マルチ上ガイド	
26 A	FB4 - 3762 - 000		2	SHEET, GUIDE ガイド シート	
27	FF5 - 7674 - 000		1	PLATE, MULTI FEED DOOR SWITCH マルチ扉スイッチ板	
28	FF5 - 7675 - 000		1	GEAR, SWING 揺動ギア	

FIGURE & KEY NO.	PART NUMBER	RANK	QTY	DESCRIPTION	SERIAL NUMBER / REMARKS
315 - 29	FF5 - 8157 - 000		1	DOOR, MULTI FEED マルチ扉	
30	FF5 - 9551 - 000		1	PLATE, SHUTTER シャッター板	
31	FF5 - 9561 - 000		1	PLATE, PICK-UP ピック アップ板	
32	FF6 - 1856 - 000		2	SUPPORT, TRAY FIXING トレイ固定板	
33	FF9 - 1763 - 000		1	ROLLER, PICK-UP, FRONT 給紙ローラ (前)	
34	FF9 - 1764 - 000		1	ROLLER, PICK-UP, REAR 給紙ローラ (後)	
35	FG6 - 1866 - 000		1	CABLE, MULTI マルチ束線	J224-227
35 A	VS1 - 5057 - 003		1	CONNECTOR, SNAP TIGHT チュウケイ コネクタ	J227
36	FH7 - 5838 - 000		1	SOLENOID ソレノイド	SL6 J227
37	FH7 - 7462 - 000		1	PHOTO-INTERRUPTER フォトインタラプタ	PS17 J226
38	FS1 - 1569 - 000		9	BUSHING ブッシング	
39	FS2 - 1357 - 000		2	BUSHING ブッシング	
40	FS5 - 3331 - 000		1	PULLEY, 14T 14T プーリ	
41	FS5 - 6581 - 000		2	SPACER, PICK-UP SHAFT 給紙軸スペーサ	
42	FS6 - 2892 - 000		1	SPRING, TENSION ヒツバリ バネ	
43	FS6 - 2893 - 000		1	SPRING, TENSION ヒツバリ バネ	
44	FS6 - 2985 - 000		1	SPRING, TENSION ヒツバリ バネ	
45	FS7 - 0039 - 000		1	GEAR, 16T 16T ギア	
46	FS7 - 0040 - 000		1	GEAR, 20T 20T ギア	
47	FS7 - 0041 - 000		1	GEAR, 16T/20T 16T / 20T ギア	
48	FS7 - 2057 - 000		1	SPRING, TENSION ヒツバリ バネ	
49	VS1 - 5057 - 012		1	CONNECTOR, SNAP TIGHT チュウケイ コネクタ	SEE NOTE 2 J224
50	WT2 - 5189 - 000		1	BUSHING ブッシング	
51	XA9 - 0628 - 000		18	SCREW,RS,M4X8 RS タイト ネジ	
52	XA9 - 0628 - 000		15	SCREW,RS,M4X8 RS タイト ネジ	
53	XA9 - 0908 - 000		1	SCREW,RS,M4X8 RS タイト ネジ	
54	XF9 - 0502 - 000		1	BELT, TIMING タイミング ベルト	
501	XB1 - 2300 - 409		2	SCREW,MACH.,TRUSS HEAD,M3X4 バインド ネジ	
502	XB1 - 2400 - 609		11	SCREW,MACH.,TRUSS HEAD,M4X6 バインド ネジ	
503	XD2 - 1100 - 322		3	RING,E E リング	

FIGURE & KEY NO.	PART NUMBER	R A N K	Q' T Y	DESCRIPTION	SERIAL NUMBER / REMARKS
315 - 504	XD2 - 1100 - 322		1	RING,E E リング	
505	XD2 - 1100 - 502		11	RING,E E リング	
506	XD3 - 1200 - 102		1	PIN,SPRING スプリング ピン	
507	XD3 - 1200 - 122		2	PIN,SPRING スプリング ピン	
508	XD3 - 2200 - 082		1	PIN,DOWEL ヘイコウ ピン	
509	XD3 - 2200 - 102		3	PIN,DOWEL ヘイコウ ピン	
510	XD3 - 2200 - 122		1	PIN,DOWEL ヘイコウ ピン	

FIGURE 316 MULTI FEED TRAY ASSEMBLY

手差し給紙トレイ部

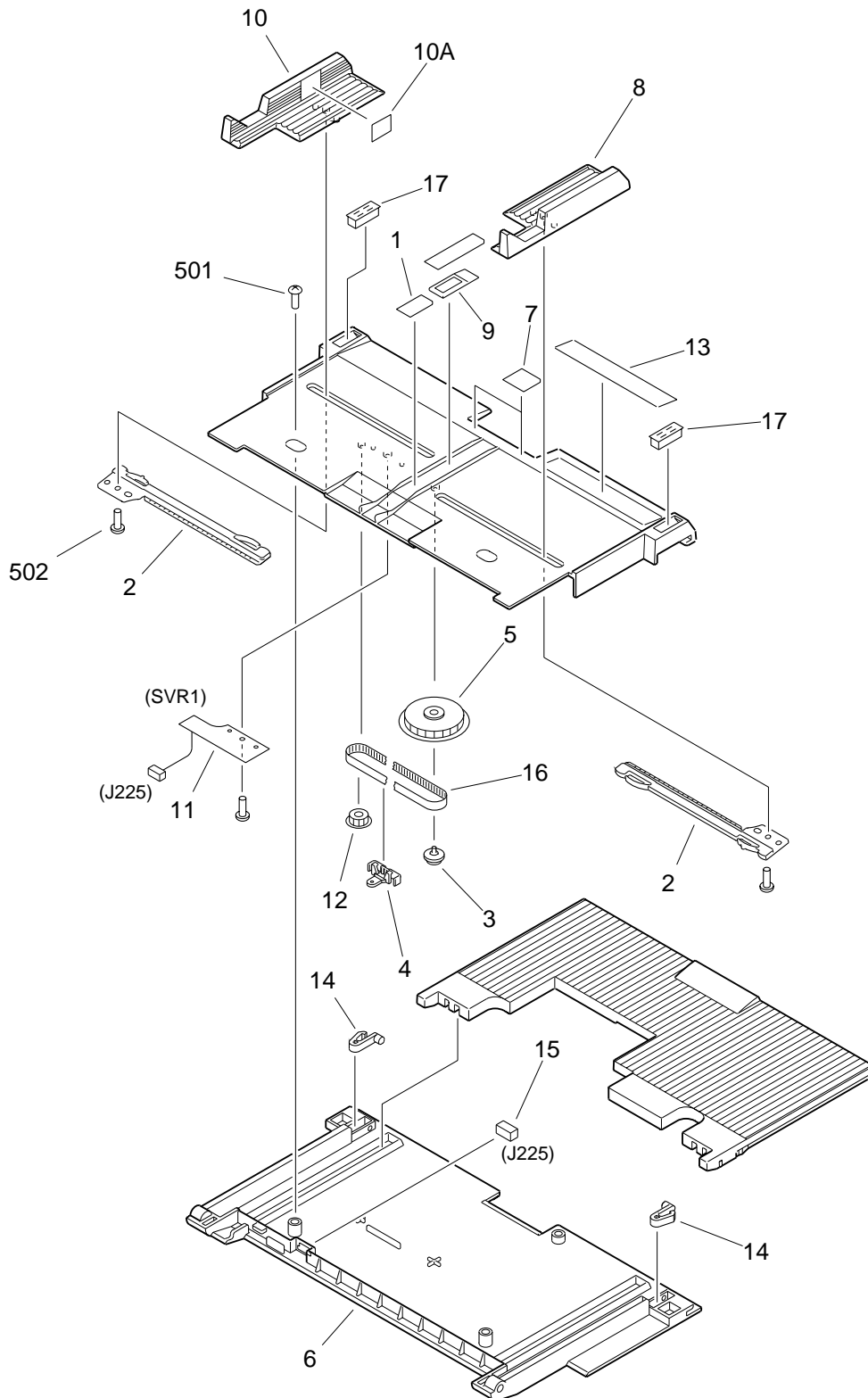

NOTE1: This assembly is included in the assembly shown in Figure 315.

NOTE2: This assembly does not include the part shown with key No.13.

注1: このユニットはFigure315のユニットに含まれます。
 注2: このユニットにKey No. 13の部品は含まれません。

FIGURE & KEY NO.	PART NUMBER	RANK	QTY	DESCRIPTION	SERIAL NUMBER / REMARKS
316 -	FG6 - 9114 - 000		1	MULTI FEED TRAY ASSEMBLY 手差し給紙トレイ部	SEE NOTE 1
1	FA9 - 3857 - 000		1	SHEET, SEPARATION 分離シート	
2	FB1 - 8619 - 000		2	RACK ラック パン	
3	FB1 - 8620 - 000		1	RING, PULLEY プ-リ リング	
4	FB1 - 8621 - 000		1	PLATE, LOCK ベルト ロック イタ	
5	FB1 - 8625 - 000		1	GEAR, 18T 18T ギア	
6	FB2 - 7521 - 000		1	BASE, TRAY マルチ トレイ ベース	
7	FB2 - 7740 - 020		2	SHEET, SEPARATION 分離シート	
8	FB4 - 3774 - 000		1	PANEL, SIDE LIMIT, FRONT サイド規制板 (前)	
9	FB6 - 2887 - 000		1	SUPPORT, MULTI PAD マルチ パッド支台	
10	FF5 - 8140 - 000		1	PANEL, SIDE LIMIT, REAR サイド規制板 (後)	
10 A	FS6 - 8709 - 000		1	LABEL, "LIMIT, PAPER HEIGHT" 用紙積載限界ラベル	
11	FG5 - 1958 - 000		1	MULTI VR PCB ASSEMBLY マルチ VR キパン プ	SVR1 J225
12	FS5 - 3177 - 000		1	PULLEY, IDLER アイドラ プーリ	
13	FS7 - 8289 - 000		1	LABEL, SIZE 手差しサイズ ラベル	AB SIZE SEE NOTE 2
	FS6 - 8706 - 000		1	LABEL, PAPER SIZE 紙サイズ ラベル	A/INCH SIZE SEE NOTE 2
	FS6 - 8707 - 000		1	LABEL, PAPER SIZE 紙サイズ ラベル	A SIZE SEE NOTE 2
	FS6 - 8708 - 000		1	LABEL, PAPER SIZE 紙サイズ ラベル	AB/INCH SIZE SEE NOTE 2
14	RA1 - 7807 - 000		2	LOCK, MP MP ロック	
15	VS1 - 5057 - 003		1	CONNECTOR, SNAP TIGHT チュウケイ コネクタ	J225
16	XF9 - 0393 - 000		1	BELT, TIMING タイミング ベルト	
17	XZ9 - 0407 - 000		2	LATCH, MAGNET マグネット キャッチ	
501	XB1 - 2400 - 606		2	SCREW, MACH., TRUSS HEAD, M4X6 バインド ネジ	
502	XB4 - 7300 - 609		3	SCREW, TAPPING, TRUSS HEAD, M3X6 バインド タッピン ネジ	

FIGURE 320 FIXING/FEEDER FRAME ASSEMBLY(1/3)

定着 / 搬送基台部(1/3)

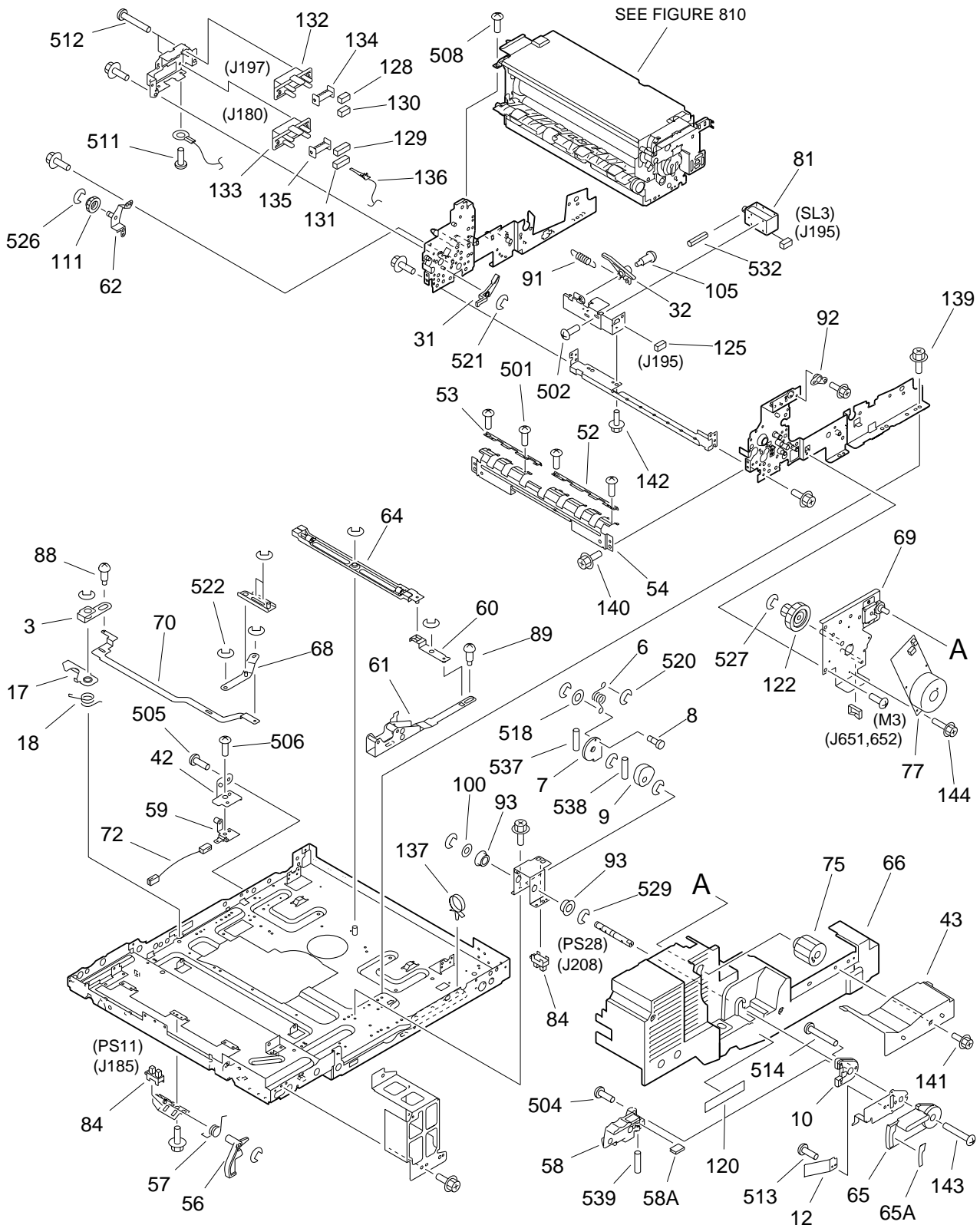

NOTE1: This assembly includes the assemblies shown in Figure 325, 330, 350, 351 and 810.
 NOTE2: This assembly does not include the parts shown with key No. 43, 66, 120, and 141.
 注1: このユニットはFigure325、330、350、351、810のユニットを含みます。
 注2: このユニットにKey No. 43、66、120、141の部番は含まれません。

FIGURE 320 FIXING/FEEDER FRAME ASSEMBLY(2/3)

定着 / 搬送基台部(2/3)

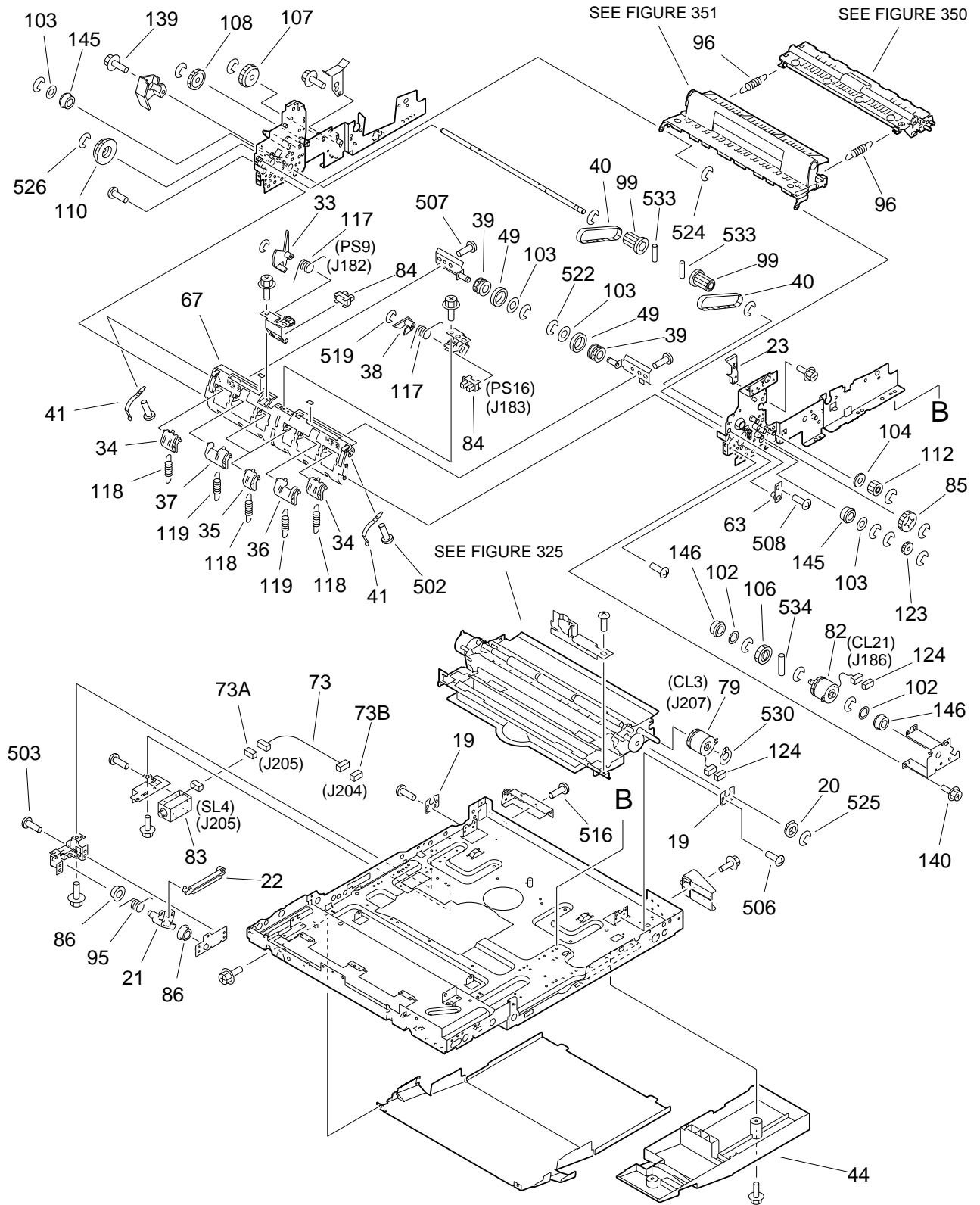

FIGURE 320 FIXING/FEEDER FRAME ASSEMBLY(3/3) 定着 / 搬送基台部(3/3)

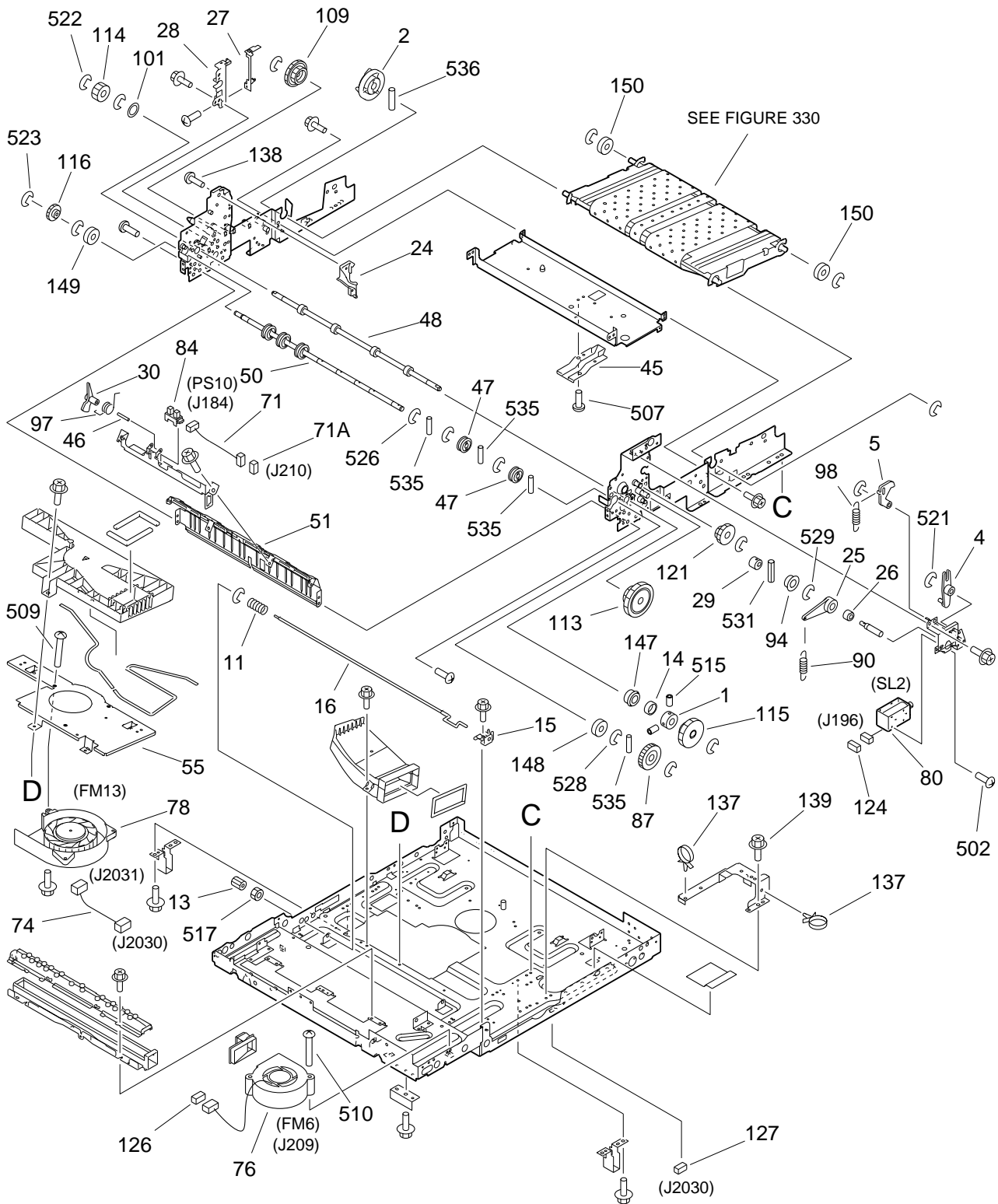

FIGURE & KEY NO.	PART NUMBER	RANK	QTY	DESCRIPTION	SERIAL NUMBER / REMARKS
320 -	FG6 - 8006 - 000		1	FIXING/FEEDER FRAME ASSEMBLY 定着 / 搬送基台部	200V SEE NOTE 1
	FG6 - 8588 - 000		1	FIXING/FEEDER FRAME ASSEMBLY 定着 / 搬送基台部	208V SEE NOTE 1
	FG6 - 8584 - 000		1	FIXING/FEEDER FRAME ASSEMBLY 定着 / 搬送基台部	220/240V SEE NOTE 1
	1 FA2 - 1753 - 000		1	COLLAR カラー	
	2 FB2 - 1035 - 000		1	COUPLING, DRIVE 駆動カップリング	
3	FB2 - 7056 - 000		1	PLATE, JOINT ジョイント板	
4	FB2 - 7242 - 000		1	ARM, SOLENOID, 1 ソレノイド アーム (1)	
5	FB2 - 7243 - 000		1	ARM, SOLENOID, 2 ソレノイド アーム (2)	
6	FB2 - 8192 - 000		1	SPRING, TORSION ネジリ バネ	
7	FB2 - 8196 - 020		1	PLATE, HANDLE STOP レジスト ハンドル ストップ板	
8	FB2 - 8198 - 000		1	SHAFT, SPRING ハンドル バネ支軸	
9	FB2 - 8204 - 000		1	CAM, REGISTRATION レジスト回転カム	
10	FB2 - 8213 - 000		1	COVER, HANDLE, REAR ハンドル裏カバー	
11	FB2 - 8214 - 000		1	SPRING, COMPRESSION アッシュク バネ	
12	FB2 - 8217 - 020		1	SPRING, LEAF 板バネ	
13	FB2 - 8376 - 000		1	GUIDE, SHAFT 軸調整ガイド	
14	FB3 - 2331 - 000		1	SPACER スペーサ	
15	FB3 - 8398 - 000		1	GUIDE, HANDLE ハンドル ガイド	
16	FB3 - 8457 - 000		1	SHAFT, HANDLE LOCK ハンドル ロック軸	
17	FB4 - 2061 - 000		1	PLATE, LATCH ラッチ板	
18	FB4 - 2062 - 000		1	SPRING, TORSION ネジリ バネ	
19	FB4 - 2067 - 000		2	PLATE, REGISTRATION ADJUSTING レジスト調整板	
20	FB4 - 2068 - 000		1	BUSHING ブッシング	
21	FB4 - 2077 - 000		1	HOOK, LOCK ロック フック	
22	FB4 - 2078 - 000		1	ARM, LOCK ロック アーム	
23	FB4 - 2224 - 000		1	GUIDE, CLAW, FRONT 2 爪ガイド (前2)	
24	FB4 - 2225 - 000		1	GUIDE, CLAW, REAR 爪ガイド (後)	
25	FB4 - 2235 - 000		1	CAM, ONE-WAY, 1 ワンウェイ カム (1)	
26	FB4 - 2236 - 000		1	CAM, ONE-WAY, 2 ワンウェイ カム (2)	
27	FB4 - 2237 - 000		1	TERMINAL, FIXING BIAS 定着バイアス接点	

FIGURE & KEY NO.	PART NUMBER	RANK	QTY	DESCRIPTION	SERIAL NUMBER / REMARKS
320 - 28	FB4 - 2238 - 000		1	MOUNT, FIXING BIAS 定着バイアス台	
29	FB4 - 2254 - 000		1	CAM, RECIPROCATING INPUT レシプロ入力カム	
30	FB4 - 2297 - 000		1	LEVER, DELIVERY SENSOR, 2 排紙センサ レバー (2)	
31	FB4 - 2299 - 000		1	LEVER, DEFLECTOR, 1 フラップ レバー (1)	
32	FB4 - 2300 - 000		1	LEVER, DEFLECTOR, 2 フラップ レバー (2)	
33	FB4 - 2303 - 000		1	LEVER, DELIVERY SENSOR 排紙センサ レバー	
34	FB4 - 2305 - 020		2	DEFLECTOR, 1 フラップ (1)	
35	FB4 - 2306 - 020		2	DEFLECTOR, 2 フラップ (2)	
36	FB4 - 2307 - 020		1	DEFLECTOR, 3 フラップ (3)	
37	FB4 - 2308 - 020		1	DEFLECTOR, 4 フラップ (4)	
38	FB4 - 2310 - 000		1	LEVER, DELIVERY SENSOR, 3 排紙センサ レバー (3)	
39	FB4 - 2312 - 000		2	ROLLER, DELIVERY AUXILIARY 排紙補助ローラ	
40	FB4 - 2314 - 000		2	BELT, TIMING タイミング ベルト	
41	FB4 - 2317 - 000		2	SPRING, LEAF 板バネ	
42	FB4 - 2327 - 000		1	TERMINAL, BIAS バイアス接点	
43	FB4 - 7878 - 000		1	COVER, TRANSFER 転写カバー	SEE NOTE 2
44	FB4 - 9797 - 020		1	COVER, FIXING/FEEDER, LOWER 定着 / 搬送カバー (下)	
45	FB5 - 0527 - 000		1	DUCT, COOLING 冷却ダクト	
46	FB5 - 0539 - 000		1	SHAFT, SENSOR 検知軸	
47	FB5 - 3407 - 000		6	ROLLER, DELIVERY, OUTER 外排紙ローラ	
48	FB5 - 7075 - 000		1	SHAFT, DELIVERY 排紙ローラ軸	
49	FB5 - 7076 - 000		2	ROLLER, REVERSE AUXILIARY 反転補助ローラ ゴム	
50	FB5 - 7655 - 000		1	SHAFT, EXTERNAL DELIVERY 外排紙ローラ軸	
51	FB5 - 7656 - 000		1	GUIDE, DELIVERY REVERSE 排紙反転ガイド	
52	FB5 - 7671 - 000		1	GUIDE, PAPER PASS, 1 通紙ガイド (1)	
53	FB5 - 7672 - 000		1	GUIDE, PAPER PASS, 2 通紙ガイド (2)	
54	FB5 - 7673 - 000		1	GUIDE, STOP 巻き込み防止ガイド	
55	FB6 - 0480 - 000		1	COVER, SEPARATION DUCT 分離ダクト蓋	
56	FB6 - 2373 - 000		1	FLAG, SENSOR 滞留センサ フラグ	
57	FB6 - 2376 - 000		1	SPRING, TORSION ネジリ バネ	

FIGURE & KEY NO.	PART NUMBER	RANK	QTY	DESCRIPTION	SERIAL NUMBER / REMARKS
320 - 58	FF5 - 6000 - 000		1	LEVER 把手	
58 A	FS6 - 8386 - 000		1	LABEL, HANDLE, 2 ハンドル ラベル (2)	
59	FF5 - 7845 - 000		1	TERMINAL, BIAS バイアス接点	
60	FF5 - 7846 - 000		1	LINK, ROTATING 回転リンク	
61	FF5 - 7850 - 000		1	LINK, SLIDE スライド リンク	
62	FF5 - 7880 - 000		1	SUPPORT, IDLER SHAFT, 4 アイドラ軸支板 (4)	
63	FF5 - 7881 - 000		1	SUPPORT, DELIVERY SHAFT 排紙軸支板	
64	FF5 - 7944 - 000		1	CROSSMEMBER, REGIST. PRESSURE レジスト加圧ステイ	
65	FF5 - 8196 - 000		1	HANDLE, FIXING/FEEDER 定着 / 搬送ハンドル	
65 A	FS6 - 8387 - 000		1	LABEL, HANDLE, 1 ハンドル ラベル (1)	
66	FF5 - 8654 - 040		1	COVER, FIXING/FEEDER 定着 / 搬送カバー	SEE NOTE 2
67	FF5 - 8736 - 000		1	GUIDE, DELIVERY, LOWER, 2 排紙下ガイド (2)	
68	FF5 - 8787 - 000		1	LINK, LATCH RELEASE, 1 ラッチ解除リンク (1)	
69	FF6 - 1017 - 000		1	MOTOR GEAR UNIT モータ ギア ユニット	
70	FF6 - 1509 - 000		1	LINK, LOCK RELEASE ロック解除リンク	
71	FG6 - 1871 - 000		1	CABLE, EXT. DELIVERY SENSOR 外排紙センサ束線	J184,210
71 A	VS1 - 5057 - 003		1	CONNECTOR, SNAP TIGHT チュウケイ コネクタ	J210
72	FG6 - 1876 - 000		1	CABLE, FIXING HIGH-VOLTAGE 定着高圧束線	
73	FG6 - 1879 - 000		1	CABLE, LOCK SOLENOID ロック ソレノイド中継束線	J204,205
73 A	VS1 - 5057 - 003		1	CONNECTOR, SNAP TIGHT チュウケイ コネクタ	J205
73 B	VS1 - 5057 - 004		1	CONNECTOR, SNAP TIGHT チュウケイ コネクタ	J204
74	FG6 - 8621 - 000		1	CABLE, SEPARATION FAN 分離ファン束線	J2030,2031
75	FG6 - 8738 - 000		1	FIXING KNOB UNIT 定着つまみ	
76	FH6 - 1548 - 000		1	FAN, COOLING 冷却ファン	FM6 J209
77	FH6 - 1937 - 000		1	MOTOR, BRUSHLESS ブラシレス モータ	M3 J651,652
78	FH6 - 1942 - 000		1	FAN, COOLING 冷却ファン	FM13 J2031
79	FH6 - 5014 - 000		1	CLUTCH, ELECTROMAGNETIC 電磁クラッチ	CL3 J207
80	FH7 - 5836 - 000		1	SOLENOID ソレノイド	SL2 J196
81	FH7 - 5837 - 000		1	SOLENOID ソレノイド	SL3 J195
82	FH7 - 5844 - 000		1	CLUTCH, ELECTROMAGNETIC 電磁クラッチ	CL21 J186

FIGURE & KEY NO.	PART NUMBER	RANK	QTY	DESCRIPTION	SERIAL NUMBER / REMARKS
320 - 83	FH7 - 5845 - 000		1	SOLENOID ソレノイド	SL4 J205
84	FH7 - 7462 - 000		5	PHOTO-INTERRUPTER フォトインタラプタ	PS9-11,16,28 J182,184,185,183,208
85	FS1 - 0542 - 000		1	GEAR, 22T 22T ギア	
86	FS1 - 1508 - 000		2	BUSHING ブッシング	
87	FS2 - 0441 - 000		1	GEAR, 28T 28T ギア	
88	FS2 - 9001 - 000		1	SCREW, STEPPED, M4 ダンピス	
89	FS2 - 9267 - 000		2	SCREW, STEPPED, M4 ダンピス	
90	FS3 - 2159 - 000		1	SPRING, TENSION ヒツバリ バネ	
91	FS4 - 2048 - 000		1	SPRING, TENSION ヒツバリ バネ	
92	FS5 - 1467 - 020		1	BUSHING, 3 ブッシング (3)	
93	FS5 - 1474 - 000		2	BUSHING ブッシング	
94	FS5 - 1803 - 000		1	BUSHING ブッシング	
95	FS5 - 2907 - 020		1	SPRING, TORSION ネジリ バネ	
96	FS5 - 2947 - 000		2	SPRING, TENSION ヒツバリ バネ	
97	FS5 - 2949 - 000		1	SPRING, TORSION ネジリ バネ	
98	FS5 - 2967 - 000		1	SPRING, TENSION ヒツバリ バネ	
99	FS5 - 3615 - 000		2	PULLEY, 18T 18T プーリ	
100	FS5 - 6329 - 000		1	SHIM, HANDLE ハンドル ワッシャ	
101	FS5 - 6487 - 000		1	SHIM ワッシャ	
102	FS5 - 6487 - 000		2	SHIM ワッシャ	
103	FS5 - 6488 - 000		4	WASHER ワッシャ	
104	FS5 - 6575 - 000		1	ROLLER, BACKLASH バックラッシュ コロ	
105	FS5 - 9210 - 000		1	SCREW, STEPPED, M4 段ピス	
106	FS6 - 0081 - 000		1	GEAR, 20T 20T ギア	
107	FS6 - 0899 - 000		1	GEAR, 38T 38T ギア	
108	FS6 - 0991 - 000		1	GEAR, 37T 37T ギア	
109	FS6 - 0992 - 000		1	GEAR, 28T/45T 28T / 45T ギア	
110	FS6 - 0993 - 000		1	GEAR, 39T/46T 39T / 46T ギア	
111	FS6 - 0994 - 000		1	GEAR, 16T/26T 16T / 26T ギア	
112	FS6 - 0995 - 000		1	GEAR, 21T 21T ギア	

FIGURE & KEY NO.	PART NUMBER	RANK	QTY	DESCRIPTION	SERIAL NUMBER / REMARKS
320 - 113	FS6 - 0996 - 000		1	GEAR, 20T/38T 20T / 38T ギア	
114	FS6 - 0997 - 000		1	GEAR, 18T 18T ギア	
115	FS6 - 0998 - 000		1	GEAR, 15T/32T 15T / 32T ギア	
116	FS6 - 0999 - 000		1	GEAR, 30T 30T ギア	
117	FS6 - 2833 - 000		2	SPRING, TORSION ネジリ バネ	
118	FS6 - 2982 - 000		4	SPRING, TENSION ヒツパリ バネ	
119	FS6 - 2993 - 020		2	SPRING, TENSION ヒツパリ バネ	
120	FS6 - 8703 - 000		1	LABEL, FIXING UNIT NUMBER 定着 / 搬送ユニット番号ラベル	SEE NOTE 2
121	FS7 - 0002 - 000		1	GEAR, 22T 22T ギア	
122	FS7 - 0006 - 000		1	GEAR, 25T/75T 25T / 75T ギア	
123	FS7 - 0899 - 000		1	GEAR, 20T 20T ギア	
124	VS1 - 5057 - 002		3	CONNECTOR, SNAP TIGHT チュウケイ コネクタ	J186,196,207
125	VS1 - 5057 - 002		1	CONNECTOR, SNAP TIGHT チュウケイ コネクタ	J195
126	VS1 - 5057 - 003		1	CONNECTOR, SNAP TIGHT チュウケイ コネクタ	J209
127	VS1 - 5057 - 003		1	CONNECTOR, SNAP TIGHT チュウケイ コネクタ	J2030
128	VS1 - 6313 - 013		1	CONNECTOR, 13P, FEMALE コネクタ (メス)	J197
129	VS1 - 6313 - 020		1	CONNECTOR, 20P, FEMALE コネクタ (メス)	J180
130	VS1 - 6314 - 013		1	CONNECTOR, 13P, FEMALE コネクタ (メス)	J197
131	VS1 - 6314 - 020		1	CONNECTOR, 20P, FEMALE コネクタ (メス)	J180
132	VS1 - 6327 - 026		1	CONNECTOR, 26P, FEMALE コネクタ (メス)	J197
133	VS1 - 6327 - 040		1	CONNECTOR, 40P, FEMALE コネクタ (メス)	J180
134	VT2 - 5161 - 026		1	HOLDER, CONNECTOR, 26P コネクタ ホルダ	J197
135	VT2 - 5161 - 040		1	HOLDER, CONNECTOR, 40P コネクタ ホルダ	J180
136	WS3 - 5609 - 000		2	SOCKET CONTACT, 12-14AWG ソケット コンタクト	J180
137	WT2 - 5565 - 000		6	CLAMP, CABLE ソクセン オサエ	
138	XA9 - 0605 - 000		13	SCREW, M4X8 タイト ネジ	
139	XA9 - 0628 - 000		54	SCREW, RS, M4X8 RS タイト ネジ	
140	XA9 - 0628 - 000		11	SCREW, RS, M4X8 RS タイト ネジ	
141	XA9 - 0643 - 000		3	SCREW, RS, M4X10 RS タイト ネジ	SEE NOTE 2
142	XA9 - 0908 - 000		2	SCREW, RS, M4X8 RS タイト ネジ	

FIGURE & KEY NO.	PART NUMBER	RANK	QTY	DESCRIPTION	SERIAL NUMBER / REMARKS
320 - 143	XA9 - 0940 - 000		1	SCREW,W/WASHER,M4X12 パネツキ バインド ネジ	
144	XA9 - 1030 - 000		4	SCREW, RS, M4X12 RS タイト ネジ	
145	XG3 - 6012 - 405		2	BEARING, BALL ボール ベアリング	
146	XG9 - 0211 - 000		2	BALL BEARING, MF128ZZ1MC3D4M ボール ベアリング	
147	XG9 - 0211 - 000		2	BALL BEARING, MF128ZZ1MC3D4M ボール ベアリング	
148	XG9 - 0250 - 000		1	BEARING, BALL ボール ベアリング	
149	XG9 - 0250 - 000		1	BEARING, BALL ボール ベアリング	
150	XG9 - 0250 - 000		2	BEARING, BALL ボール ベアリング	
501	XB1 - 2260 - 407		4	SCREW,MACH.,TRUSS HEAD,M2.6X4 バインド ネジ	
502	XB1 - 2300 - 407		8	SCREW,MACH.,TRUSS HEAD,M3X4 バインド ネジ	
503	XB1 - 2300 - 609		1	SCREW,MACH.,TRUSS HEAD,M3X6 バインド ネジ	
504	XB1 - 2300 - 809		2	SCREW,MACH.,TRUSS HEAD,M3X8 バインド ネジ	
505	XB1 - 2400 - 407		1	SCREW,MACH.,TRUSS HEAD,M4X4 バインド ネジ	
506	XB1 - 2400 - 409		4	SCREW,MACH.,TRUSS HEAD,M4X4 バインド ネジ	
507	XB1 - 2400 - 609		46	SCREW,MACH.,TRUSS HEAD,M4X6 バインド ネジ	
508	XB1 - 2400 - 609		5	SCREW,MACH.,TRUSS HEAD,M4X6 バインド ネジ	
509	XB1 - 2401 - 409		3	SCREW,MACH.,TRUSS HEAD,M4X14 バインド ネジ	
510	XB1 - 2404 - 009		2	SCREW,MACH.,TRUSS HEAD,M4X40 バインド ネジ	
511	XB2 - 7400 - 806		1	SCREW,W/WASHER,M4X8 パネツキ バインド ネジ	
512	XB2 - 8401 - 009		4	SCREW,W/WASHER,M4X10 パネツキ バインド ネジ	
513	XB4 - 7300 - 809		2	SCREW,TAPPING,TRUSS HEAD,M3X8 バインド タッピン ネジ	
514	XB4 - 7301 - 609		1	SCREW,TAPPING,TRUSS HEAD,M3X16 バインド タッピン ネジ	
515	XB6 - 2400 - 509		2	SETSCREW,M4X5 ロツカク アナツキ トメネジ	
516	XB6 - 7400 - 609		3	SCREW,TP,M4X6 TP ネジ	
517	XB7 - 2100 - 309		1	NUT,HEX,M3 ロツカク ナット	
518	XD1 - 1103 - 137		1	SHIM ヒョウジュン ワッシャ	
519	XD2 - 1100 - 172		2	RING,E E リング	
520	XD2 - 1100 - 242		2	RING,E E リング	
521	XD2 - 1100 - 322		5	RING,E E リング	
522	XD2 - 1100 - 502		15	RING,E E リング	

FIGURE & KEY NO.	PART NUMBER	RANK	QTY	DESCRIPTION	SERIAL NUMBER / REMARKS
320 - 523	XD2 - 1100 - 502		1	RING,E E リング	
524	XD2 - 1100 - 602		1	RING,E E リング	
525	XD2 - 1100 - 642		8	RING,E E リング	
526	XD2 - 1100 - 642		35	RING,E E リング	
527	XD2 - 1100 - 642		1	RING,E E リング	
528	XD2 - 1100 - 642		4	RING,E E リング	
529	XD2 - 1100 - 802		15	RING,E E リング	
530	XD2 - 2100 - 802		1	RING,GRIP グリップ リング	
531	XD3 - 1200 - 102		1	PIN,SPRING スプリング ピン	
532	XD3 - 1300 - 082		1	PIN,SPRING スプリング ピン	
533	XD3 - 2200 - 102		3	PIN,DOWEL ヘイコウ ピン	
534	XD3 - 2200 - 122		1	PIN,DOWEL ヘイコウ ピン	
535	XD3 - 2200 - 142		7	PIN,DOWEL ヘイコウ ピン	
536	XD3 - 2200 - 162		1	PIN,DOWEL ヘイコウ ピン	
537	XD3 - 2200 - 202		1	PIN,DOWEL ヘイコウ ピン	
538	XD3 - 2300 - 202		1	PIN,DOWEL ヘイコウ ピン	
539	XD3 - 2300 - 322		1	PIN,DOWEL ヘイコウ ピン	

FIGURE 325 REGISTRATION/TRANSFER ASSEMBLY
レジスト/転写部

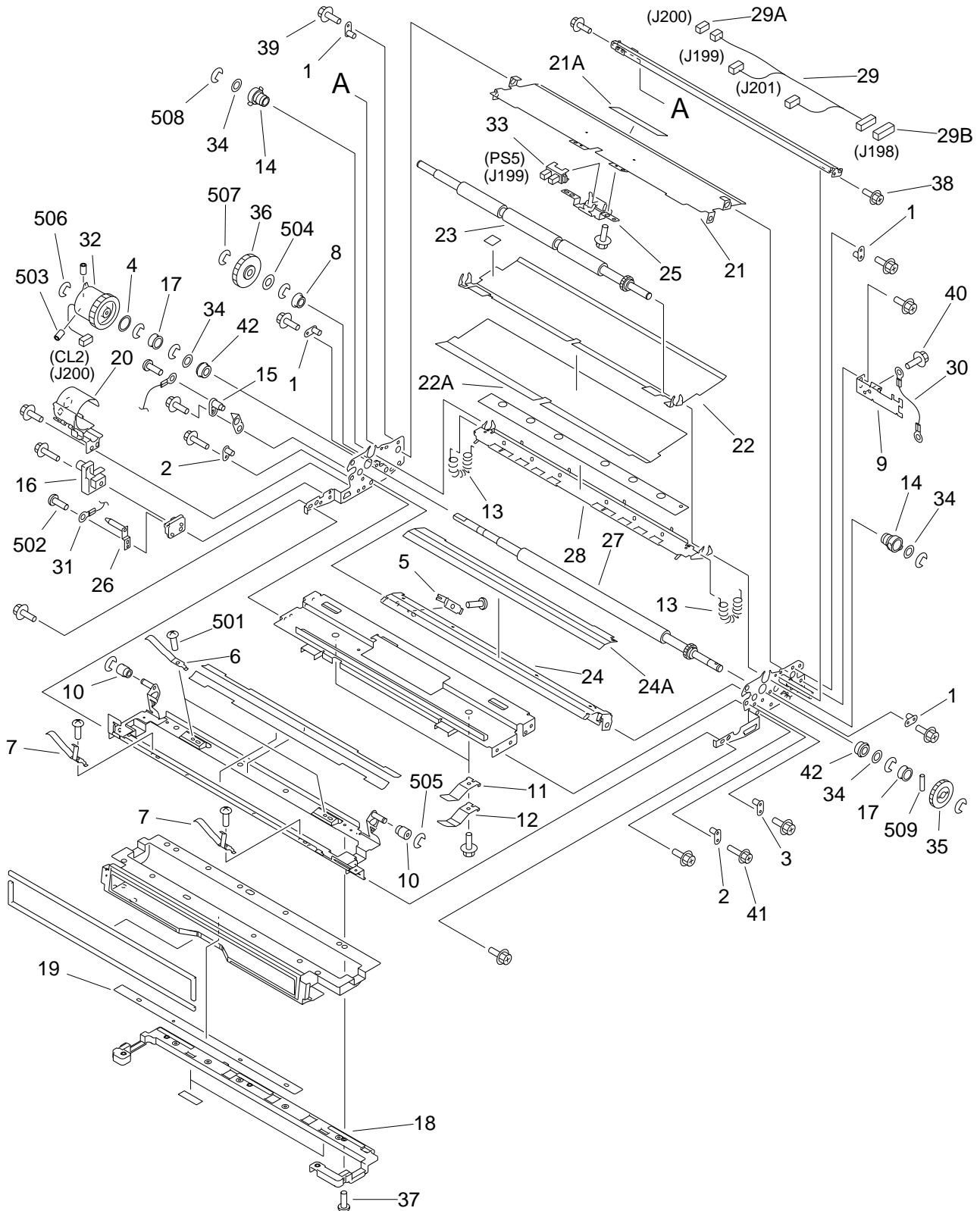

NOTE: This assembly is included in the assembly shown in Figure 320.
注：このユニットはFigure320のユニットに含まれます。

FIGURE & KEY NO.	PART NUMBER	RANK	QTY	DESCRIPTION	SERIAL NUMBER / REMARKS
325 -	FG6 - 8032 - 000		1	REGISTRATION/TRANSFER ASSEMBLY レジスト/転写部	SEE NOTE
1	FA3 - 9120 - 000		4	PIN, GUIDE フロート ピン	
2	FA4 - 1149 - 000		2	PIN, PLATE 絶縁ピン	
3	FA5 - 2839 - 000		1	PLATE, PIN フロート ピン	
4	FB2 - 6285 - 000		1	SHIM ワッシャ	
5	FB4 - 1670 - 000		1	TERMINAL, LOWER GUIDE 下ガイド接点	
6	FB4 - 1679 - 000		2	SPRING, LEAF 板バネ	
7	FB4 - 1719 - 000		2	SPRING, LEAF 板バネ	
8	FB4 - 2068 - 000		1	BUSHING ブッシング	
9	FB4 - 2322 - 020		1	PLATE, STOP 回転止め板	
10	FB4 - 3850 - 000		2	COLLAR, POSITIONING 位置決めコロ	
11	FB4 - 3851 - 000		2	SPRING, LEAF 板バネ	
12	FB4 - 3852 - 000		2	SPRING, LEAF 板バネ	
13	FB4 - 3858 - 000		2	SPRING, TENSION ヒツパリ バネ	
14	FB4 - 3860 - 000		2	BUSHING ブッシング	
15	FB4 - 9033 - 000		1	PLATE, PIN フロート ピン	
16	FB4 - 9515 - 000		1	COVER, TERMINAL 接点カバー	
17	FB5 - 7676 - 000		2	COLLAR, REGISTRATION, LOWER レジスト カラー (下)	
18	FB6 - 0473 - 000		1	RETAINER, DUCT, 1 ダクト押え (1)	
19	FB6 - 0474 - 000		1	RETAINER, DUCT, 2 ダクト押え (2)	
20	FB6 - 2372 - 000		1	COVER, REGISTRATION CLUTCH レジスト クラッチ カバー	
21	FF5 - 7872 - 000		1	GUIDE, REGISTRATION, LOWER レジスト前ガイド (下)	
21 A	FB4 - 3853 - 000		1	SHEET, PROTECTIVE 保護シート	
22	FF5 - 7875 - 000		1	GUIDE, REGISTRATION, UPPER レジスト前ガイド (上)	
22 A	FB4 - 3857 - 000		1	SHEET, PROTECTIVE 保護シート	
23	FF5 - 7877 - 000		1	ROLLER, REGISTRATION, UPPER レジスト ローラ (上)	
24	FF5 - 7878 - 000		1	GUIDE, PRE-TRANSFER, LOWER 転写前ガイド (下)	
24 A	FB4 - 1667 - 000		1	SHEET, PROTECTIVE 保護シート	
25	FF5 - 8194 - 000		1	MOUNT, PAPER SENSOR 紙検知台	
26	FF5 - 8796 - 000		1	PIN, PAPER FEEDER 紙搬送接点	

FIGURE & KEY NO.	PART NUMBER	RANK	QTY	DESCRIPTION	SERIAL NUMBER / REMARKS
325 - 27	FF6 - 1049 - 000		1	ROLLER, REGISTRATION, LOWER レジスト ローラ (下)	
28	FF6 - 1053 - 000		1	GUIDE, PRE-TRANSFER, UPPER 転写前ガイド (上)	
29	FG6 - 1872 - 000		1	CABLE, REGISTRATION レジスト束線	J198-201
29A	VS1 - 5057 - 002		1	CONNECTOR, SNAP TIGHT チュウケイ コネクタ	J200
29B	VS1 - 5057 - 007		1	CONNECTOR, SNAP TIGHT チュウケイ コネクタ	J198
30	FG6 - 1873 - 000		1	CABLE, GROUNDING アース線	
31	FG6 - 1874 - 000		1	CABLE, FEEDER HIGH-VOLTAGE 搬送高圧束線	
32	FH6 - 5013 - 000		1	CLUTCH, ELECTROMAGNETIC 電磁クラッチ	CL2 J200
33	FH7 - 7462 - 000		1	PHOTO-INTERRUPTER フォトインタラプタ	PS5 J199
34	FS5 - 6487 - 000		4	SHIM ワッシャ	
35	FS6 - 0056 - 000		1	GEAR, 32T 32T ギア	
36	FS7 - 0901 - 000		1	GEAR, 38T 38T ギア	
37	XA9 - 0253 - 000		7	SCREW, MACH., PAN HEAD, M3X8 ナベ ネジ	
38	XA9 - 0626 - 000		2	SCREW, RS, M3X6 RS タイト ネジ	
39	XA9 - 0628 - 000		21	SCREW, RS, M4X8 RS タイト ネジ	
40	XA9 - 0633 - 000		1	SCREW, RS, M4X8 RS タイト ネジ	
41	XA9 - 1030 - 000		3	SCREW, RS, M4X12 RS タイト ネジ	
42	XG9 - 0472 - 000		2	BALL BEARING, MF128ZZ1MC3EECZZ ボール ベアリング	
501	XB1 - 2300 - 409		4	SCREW, MACH., TRUSS HEAD, M3X4 バインド ネジ	
502	XB2 - 7300 - 607		5	SCREW, W/WASHER, M3X6 パネツキ バインド ネジ	
503	XB6 - 2400 - 609		2	SETSCREW, M4X6 ロツカク アナツキ トメネジ	
504	XD1 - 1108 - 212		1	SHIM ヒョウジュン ワッシャ	
505	XD2 - 1100 - 322		2	RING, E E リング	
506	XD2 - 1100 - 402		1	RING, E E リング	
507	XD2 - 1100 - 502		1	RING, E E リング	
508	XD2 - 1100 - 642		8	RING, E E リング	
509	XD3 - 2200 - 142		1	PIN, DOWEL ヘイコウ ピン	

FIGURE 330 FEEDER ASSEMBLY 搬送部

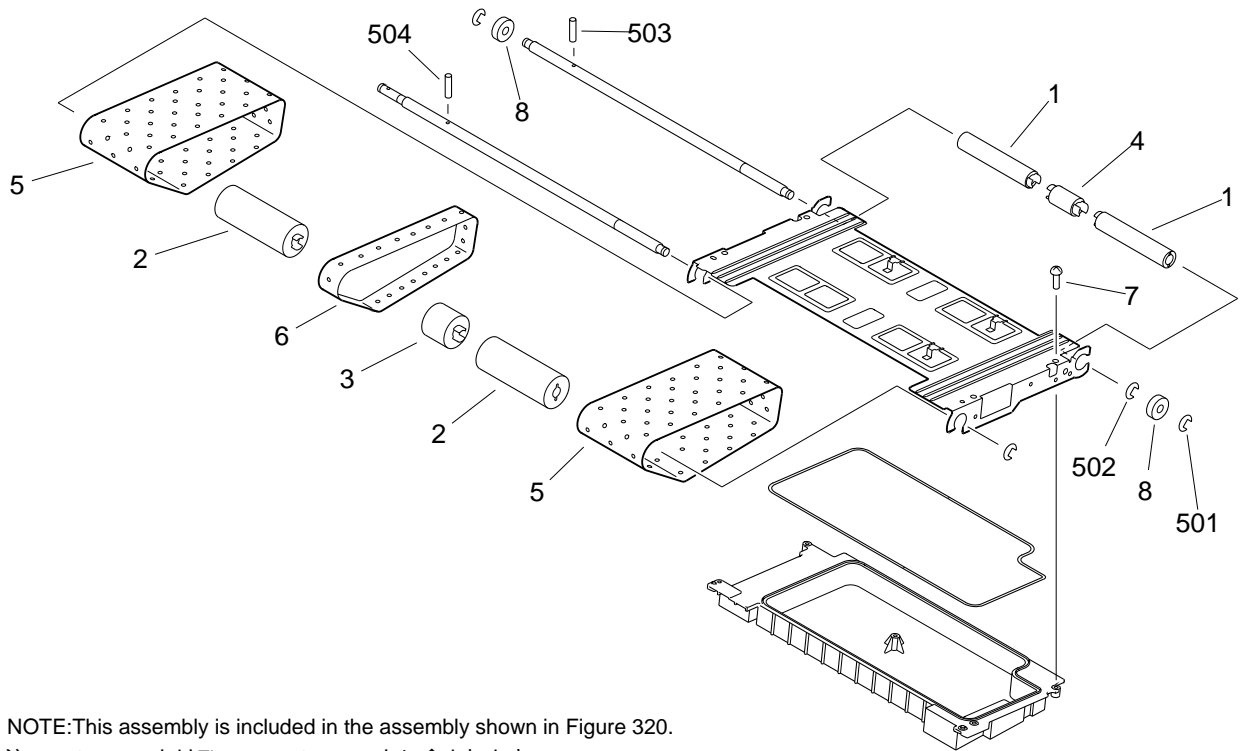

NOTE: This assembly is included in the assembly shown in Figure 320.
注：このユニットはFigure320のユニットに含まれます。

FIGURE & KEY NO.	PART NUMBER	RANK	QTY	DESCRIPTION	SERIAL NUMBER / REMARKS
330 -	FG6 - 8033 - 000		1	FEEDER ASSEMBLY 搬送部	SEE NOTE
1	FB4 - 2088 - 000		2	ROLLER, IDLER 従動ローラ	
2	FB4 - 2090 - 000		2	ROLLER, FEEDER BELT DRIVE 駆動ローラ	
3	FB4 - 2093 - 000		1	ROLLER, FEEDER BELT DRIVE 駆動ローラ	
4	FB4 - 2094 - 000		1	ROLLER, IDLER 従動ローラ	
5	FB6 - 0484 - 000		2	BELT, PAPER FEED 搬送ベルト	
6	FB6 - 0485 - 000		1	BELT, PAPER FEED 搬送ベルト	
7	XA9 - 0605 - 000		5	SCREW, M4X8 タイト ネジ	
8	XG9 - 0250 - 000		2	BEARING, BALL ボール ベアリング	
501	XD2 - 1100 - 642		2	RING, E E リング	
502	XD2 - 1100 - 802		2	RING, E E リング	
503	XD3 - 2200 - 142		1	PIN, DOWEL ヘイコウ ピン	
504	XD3 - 2200 - 162		1	PIN, DOWEL ヘイコウ ピン	

FIGURE 350 INTERNAL DELIVERY UPPER ASSEMBLY

内排紙上部

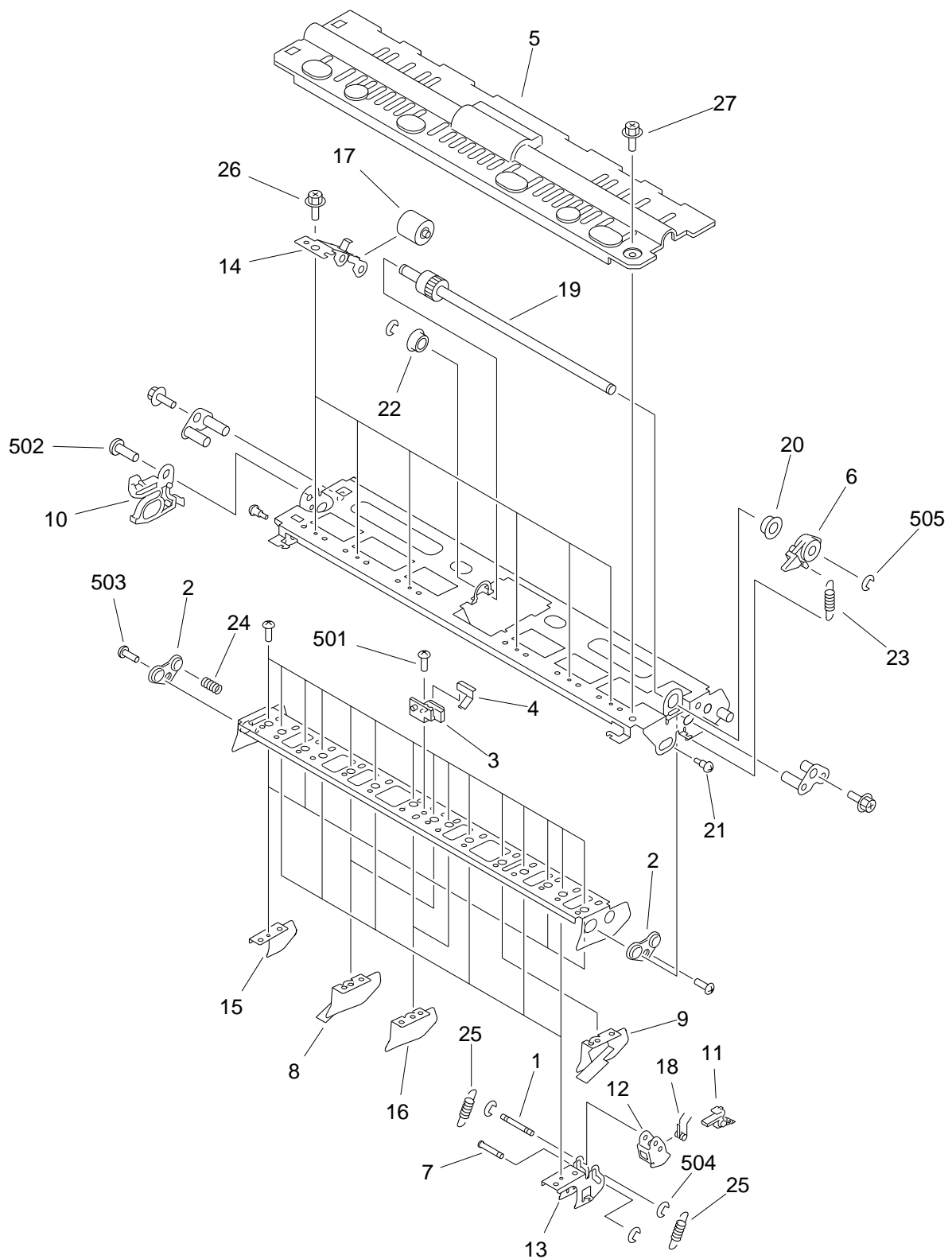

NOTE: This assembly is included in the assembly shown in Figure 320.
 注：このユニットはFigure320のユニットに含まれます。

FIGURE & KEY NO.	PART NUMBER	R A N K	Q' T Y	DESCRIPTION	SERIAL NUMBER / REMARKS
350 -	FG6 - 8041 - 000		1	INTERNAL DELIVERY UPPER ASS'Y 内排紙上部	SEE NOTE
1	FA3 - 2764 - 020		6	ROD 2, SEPARATION CLAW, UPPER 上分離爪軸 (2)	
2	FB2 - 7163 - 000		2	BUSHING ブッシング	
3	FB2 - 7168 - 000		1	MOUNT, PIN リ - ド ピン	
4	FB2 - 7169 - 000		1	PLATE, RATCHET ラチェット板	
5	FB2 - 7174 - 040		1	COVER, INTERNAL DELIVERY, UPPER 内排紙カバー - (上)	
6	FB3 - 8369 - 000		1	LEVER, ONE-WAY ワンウェイ レバ -	
7	FB3 - 8414 - 000		6	ROD 1, SEPARATION CLAW, UPPER 上分離爪軸 (1)	
8	FB4 - 2261 - 000		2	PLATE, UPPER GUIDE, 1 上ガイド板 (1)	
9	FB4 - 2262 - 000		1	PLATE, UPPER GUIDE, 2 上ガイド板 (2)	
10	FB4 - 2263 - 000		1	GUIDE, LOCK 開閉ロック ガイド	
11	FB5 - 3625 - 000		6	CLAW, SEPARATING 上分離爪	
12	FB5 - 6974 - 000		6	MOUNT, CLAW, UPPER 分離爪台 (上)	
13	FB5 - 6976 - 000		6	SUPPORT, SEPARATION CLAW 爪支板	
14	FB5 - 7666 - 000		6	HOLDER, FEEDER ROLLER 搬送コロ ホルダ	
15	FB5 - 7668 - 000		4	GUIDE, UPPER, 1 上ガイド (1)	
16	FB5 - 8717 - 000		2	GUIDE, UPPER, 2 上ガイド (2)	
17	FB5 - 8729 - 000		6	ROLLER, INSIDE DELIVERY 内排紙コロ	
18	FB6 - 0599 - 000		6	SPRING, TORSION ネジリ パネ	
19	FF5 - 5914 - 000		1	SHAFT, RECIPROICATION レシプロ軸	
20	FS1 - 1401 - 000		1	BUSHING ブッシング	
21	FS1 - 9199 - 000		2	SCREW, STEPPED, M4 段ビス	
22	FS5 - 1372 - 000		1	BUSHING ブッシング	
23	FS5 - 2946 - 000		1	SPRING, TENSION ヒツパリ パネ	
24	FS5 - 2953 - 020		1	SPRING, COMPRESSION アッシュク パネ	
25	FS7 - 2319 - 000		12	SPRING, TENSION ヒツパリ パネ	
26	XA9 - 0625 - 000		6	SCREW, RS, M3X4 RS タイト ネジ	
27	XA9 - 0628 - 000		3	SCREW, RS, M4X8 RS タイト ネジ	
501	XB1 - 2300 - 409		16	SCREW, MACH., TRUSS HEAD, M3X4 バインド ネジ	
502	XB1 - 2400 - 609		1	SCREW, MACH., TRUSS HEAD, M4X6 バインド ネジ	

FIGURE & KEY NO.	PART NUMBER	R A N K	Q' T Y	DESCRIPTION	SERIAL NUMBER / REMARKS
350 - 503	XB6 - 7300 - 609		2	SCREW,TP,M3X6 TP ネジ	
504	XD2 - 1100 - 242		18	RING,E E リング	
505	XD2 - 1100 - 502		2	RING,E E リング	

FIGURE 351 EXTERNAL DELIVERY UPPER ASSEMBLY 外排紙上部

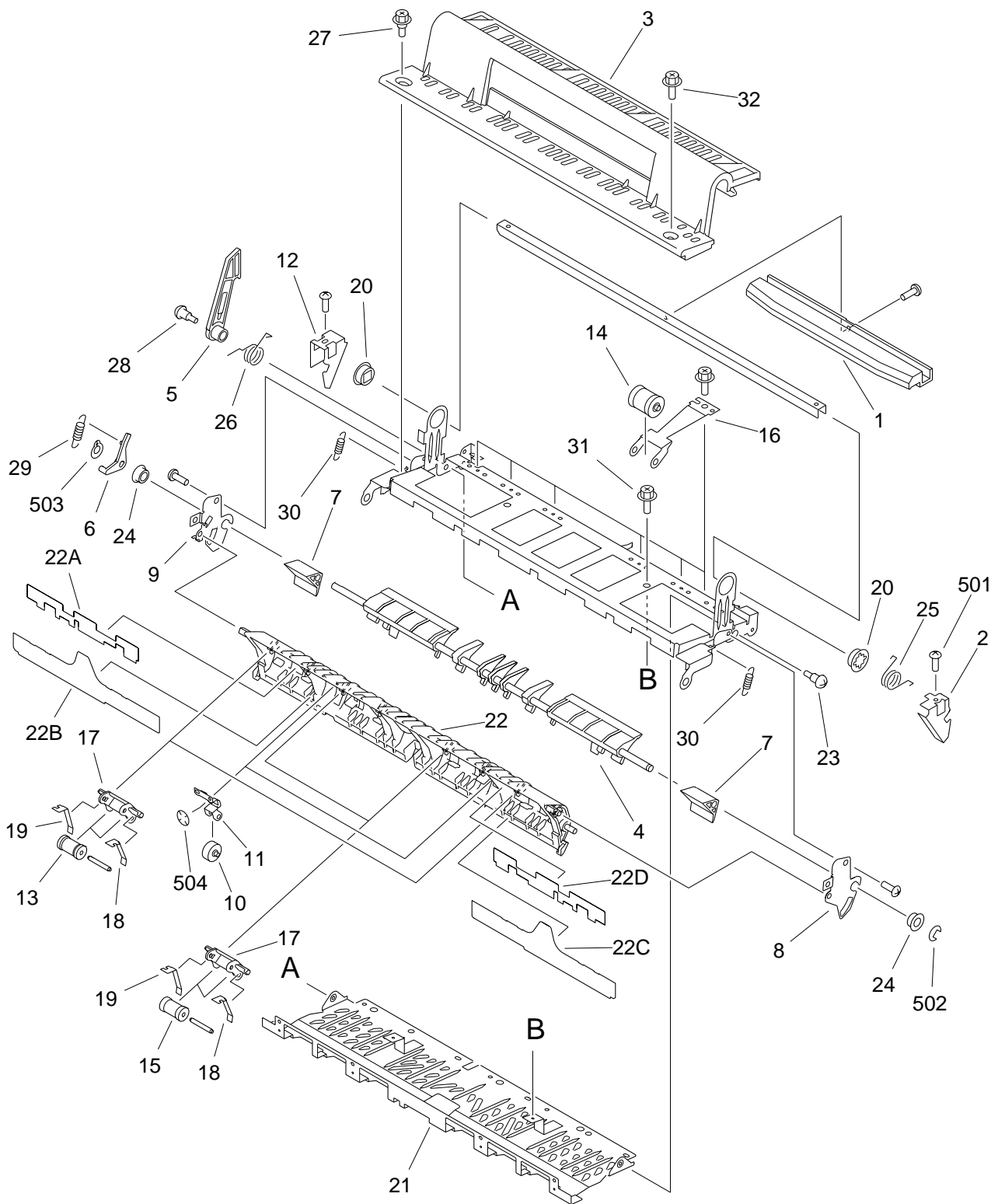

NOTE1: This assembly is included in the assembly shown in Figure 320.

NOTE2: This assembly does not include the parts shown with key No. 3, 27, and 32.

注1: このユニットはFigure320のユニットに含まれます。

注2: このユニットにKey No. 3、27、32の部品は含まれません。

FIGURE & KEY NO.	PART NUMBER	RANK	QTY	DESCRIPTION	SERIAL NUMBER / REMARKS
351 -	FG6 - 7366 - 000		1	EXTERNAL DELIVERY UPPER ASS'Y 外排紙上部	SEE NOTE 1
1	FB2 - 7137 - 000		1	HANDLE, FEEDER ハিশ トッテ	
2	FB2 - 7181 - 000		1	PLATE, LOCK, FRONT ロック ツメ (マエ)	
3	FB4 - 2268 - 000		1	COVER, EXTERNAL DELIVERY, UPPER 外排紙カバー (上)	SEE NOTE 2
4	FB4 - 2270 - 000		1	DEFLECTOR, 1 フラッパ (1)	
5	FB4 - 2271 - 000		1	ARM, LOCK 開閉ロック	
6	FB4 - 2272 - 000		1	ARM, DEFLECTOR フラッパ アーム	
7	FB4 - 2284 - 000		2	GUIDE, AUXILIARY, 1 補助ガイド (1)	
8	FB4 - 2288 - 000		1	SUPPORT, DEFLECTOR, FRONT フラッパ支持板 (前)	
9	FB4 - 2289 - 000		1	SUPPORT, DEFLECTOR, REAR フラッパ支持板 (後)	
10	FB4 - 2293 - 000		2	ROLLER, IDLER 従動ローラ	
11	FB4 - 2294 - 000		2	HOLDER, ROLLER 従動ローラ ホルダ	
12	FB5 - 2508 - 000		1	PLATE, LOCK, REAR ロック爪 (後)	
13	FB5 - 3395 - 000		4	ROLLER, CURL カール付けコロ	
14	FB5 - 3410 - 000		6	ROLLER, EXTERNAL DELIVERY 外排紙コロ	
15	FB5 - 3421 - 000		4	ROLLER, CURL, 2 カール付けコロ (2)	
16	FB5 - 7657 - 000		6	HOLDER, FEEDER ROLLER 搬送コロ ホルダ	
17	FB5 - 7662 - 000		4	HOLDER, ROLLER ローラ ホルダ	
18	FB5 - 7663 - 000		4	SPRING, LEAF 板バネ	
19	FB5 - 7664 - 000		4	SPRING, LEAF 板バネ	
20	FC1 - 7438 - 000		2	BUSHING ブッシング	
21	FF6 - 1029 - 000		1	GUIDE, EXTERNAL DELIVERY 外排紙上ガイド	
22	FF6 - 1046 - 000		1	GUIDE, FEEDER ROLLER 搬送ローラ ガイド	
22 A	FB5 - 7674 - 000		1	SHEET, PROTECTIVE 保護シート	
22 B	FB5 - 7677 - 000		1	SHEET, PROTECTIVE 保護シート	
22 C	FB5 - 7678 - 000		1	SHEET, PROTECTIVE 保護シート	
22 D	FB5 - 8718 - 000		1	SHEET, PROTECTIVE 保護シート	
23	FS1 - 9199 - 000		1	SCREW, STEPPED, M4 段ビス	
24	FS5 - 1004 - 000		2	BUSHING, POLYACETAR ブッシング	
25	FS5 - 2944 - 000		1	SPRING, TORSION ネジリ バネ	

FIGURE & KEY NO.	PART NUMBER	R A N K	Q' T Y	DESCRIPTION	SERIAL NUMBER / REMARKS
351 - 26	FS5 - 2982 - 000		1	SPRING, TORSION ネジリ バネ	SEE NOTE 2
27	FS5 - 9277 - 000		1	SCREW,RS STEPPED,M4 RS タイト 段ビス	
28	FS5 - 9284 - 000		1	SCREW,STEPPED ダン ビス	
29	FS6 - 2885 - 000		1	SPRING, TENSION ヒツパリ バネ	
30	FS6 - 2886 - 000		2	SPRING, TENSION ヒツパリ バネ	
31	XA9 - 0626 - 000		8	SCREW,RS,M3X6 RS タイト ネジ	SEE NOTE 2
32	XA9 - 0628 - 000		1	SCREW,RS,M4X8 RS タイト ネジ	
501	XB1 - 2300 - 609		7	SCREW,MACH.,TRUSS HEAD,M3X6 バインド ネジ	
502	XD2 - 1100 - 402		1	RING,E E リング	
503	XD2 - 2100 - 502		1	RING,GRIP グリップ リング	
504	XD2 - 2300 - 242		4	RING,TOOTHED LOCK ハツキ トメワ	

FIGURE 360 DUPLEXING FEEDER ASSEMBLY(1/3)

両面搬送部(1/3)

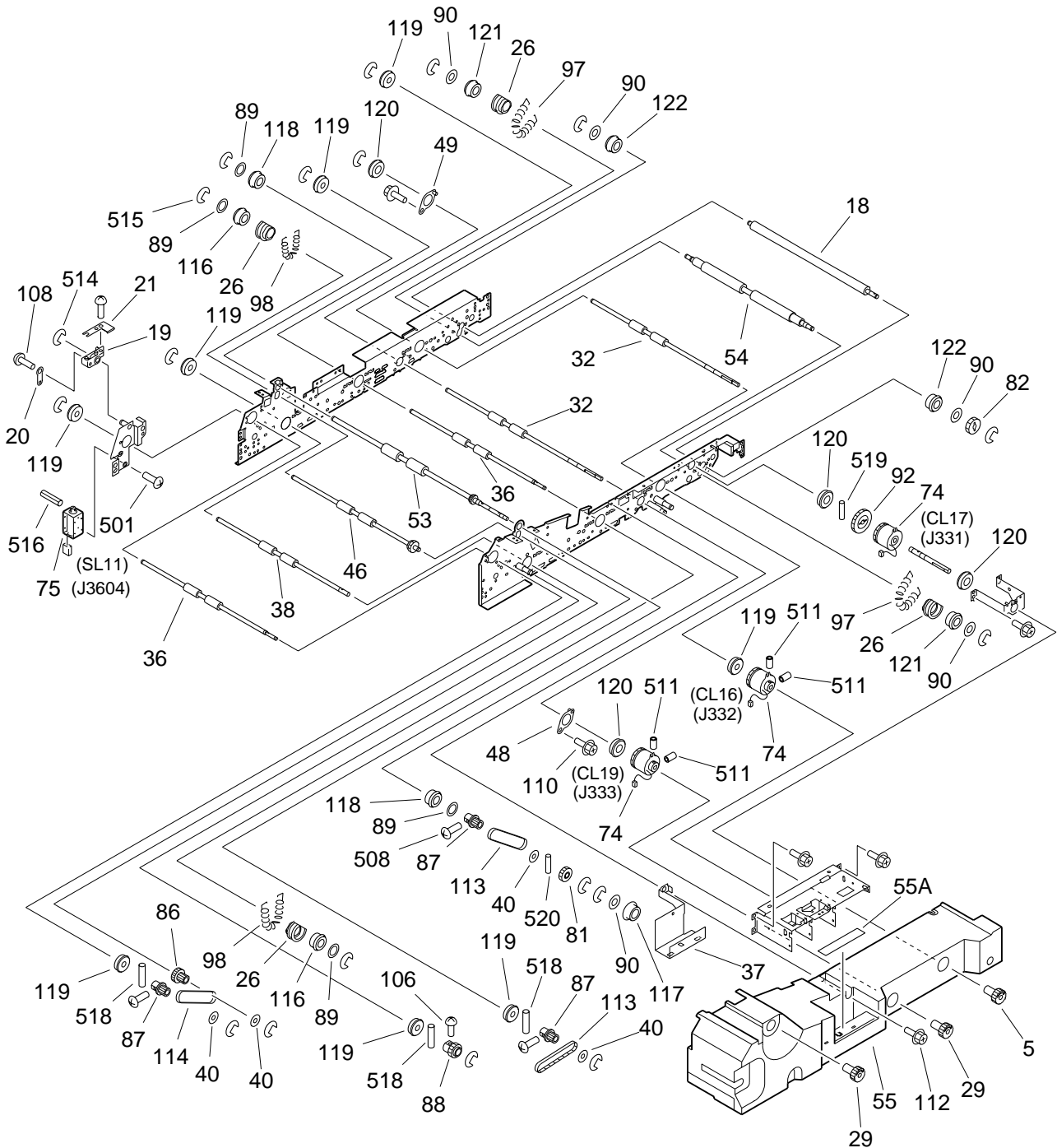

FIGURE 360 DUPLEXING FEEDER ASSEMBLY(2/3)
両面搬送部(2/3)

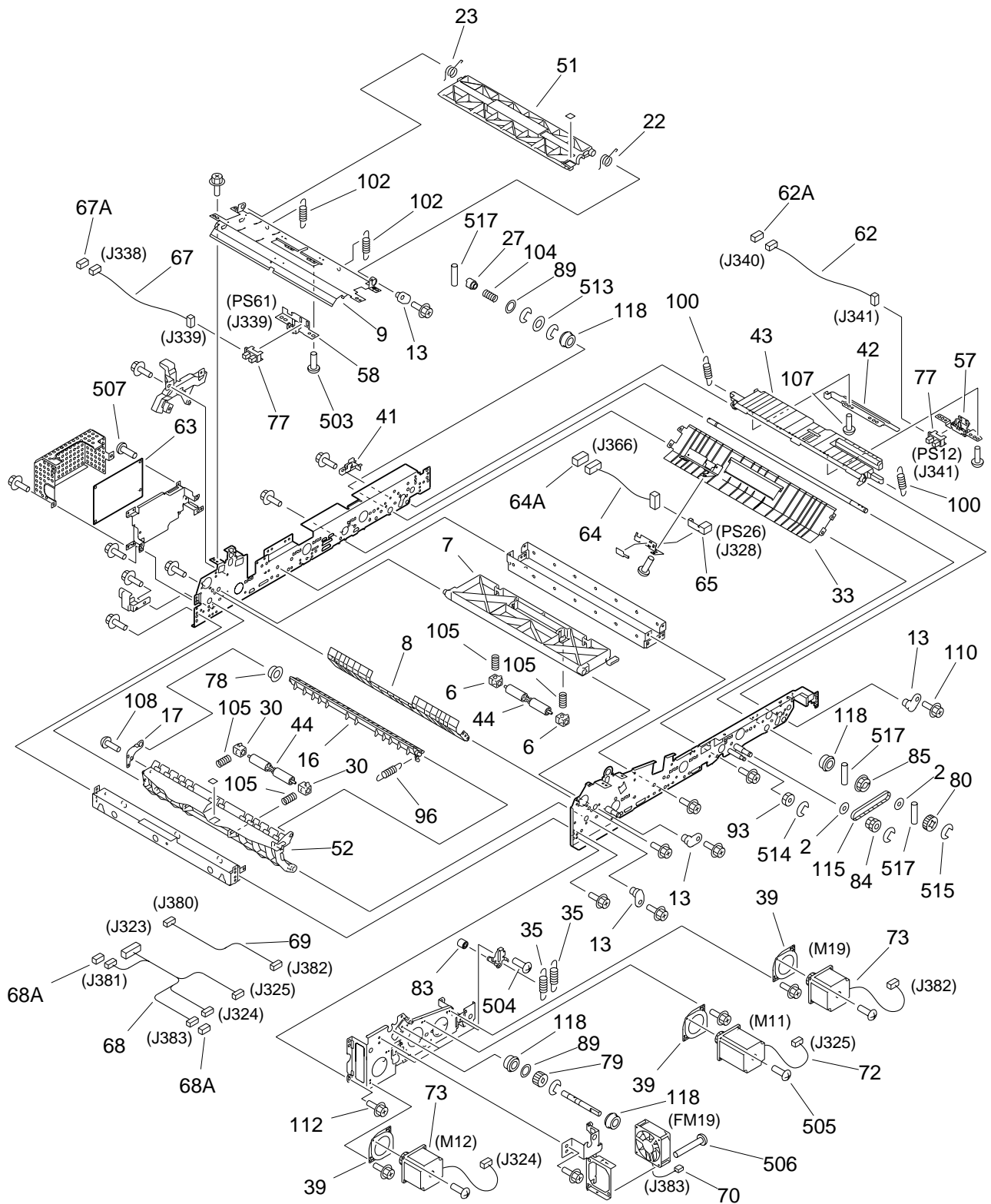

FIGURE 360 DUPLEXING FEEDER ASSEMBLY(3/3)

両面搬送部(3/3)

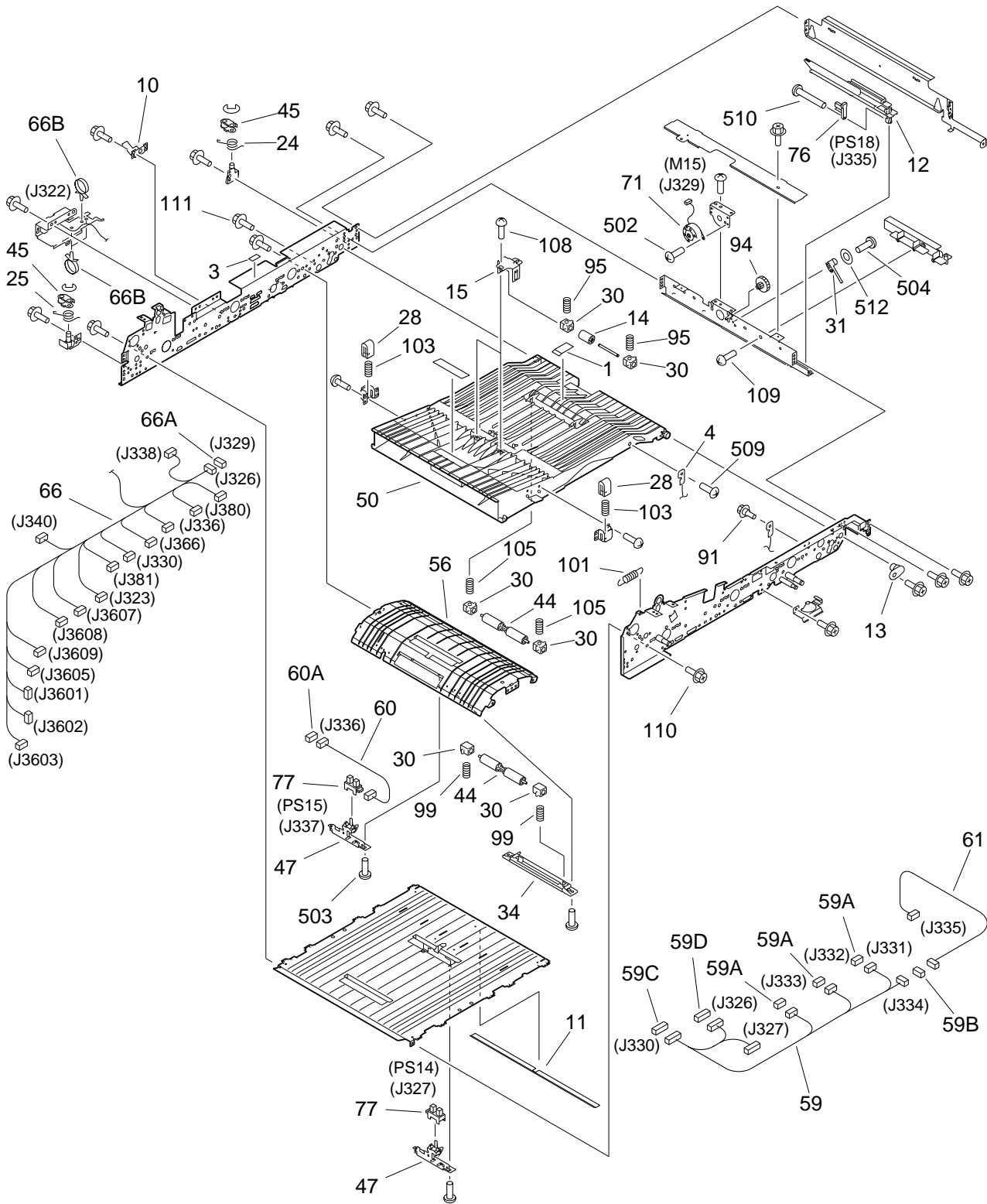

FIGURE & KEY NO.	PART NUMBER	RANK	QTY	DESCRIPTION	SERIAL NUMBER / REMARKS
360 -	FG6 - 8015 - 000		1	DUPLEXING FEEDER ASSEMBLY 両面搬送部	
1	FA6 - 3672 - 000		1	PLATE, LOWER FEEDER SUPPORT 下搬送ガイド補助板	
2	FA6 - 7939 - 000		6	FLANGE, PULLEY, 2 プーリー フランジ (2)	
3	FA9 - 3822 - 000		1	LABEL, DISCRIMINATE 識別ラベル	
4	FB1 - 7041 - 000		1	WIRE, RIGHT DOOR SUPPORTING 右扉支え ワイヤ	
5	FB2 - 2139 - 020		1	KNOB ツマミ	
6	FB2 - 7755 - 000		2	BUSHING ブッシング	
7	FB4 - 2106 - 000		1	GUIDE, REVERSE DELIVERY 反転排紙ガイド	
8	FB4 - 2113 - 000		1	GUIDE, REVERSING, LOWER 反転ガイド(下)	
9	FB4 - 2114 - 020		1	GUIDE, REVERSING, UPPER 反転ガイド(上)	
10	FB4 - 2121 - 000		1	PLATE, DECK PRESSURE デッキ押し板	
11	FB4 - 2122 - 000		1	SHEET, FEEDER, LOWER 搬送シート(下)	
12	FB4 - 2124 - 000		1	GUIDE, SIDE REGISTRATION SLIDE 横レジ スライド ガイド	
13	FB4 - 2131 - 000		5	GUIDE, HINGE ヒンジ ガイド	
14	FB4 - 2132 - 000		2	ROLLER, FEED 搬送ローラ	
15	FB4 - 2133 - 000		2	HOLDER, ROLLER ローラ ホルダ	
16	FB4 - 2135 - 000		1	DEFLECTOR フラッパ	
17	FB4 - 2136 - 000		1	SUPPORT, DEFLECTOR フラッパ支持板	
18	FB4 - 2145 - 000		1	ROLLER, STEEL 鉄ローラ	
19	FB4 - 2149 - 000		1	ARM, SOLENOID ソレノイド アーム	
20	FB4 - 2150 - 000		1	LINK, SOLENOID ソレノイド リンク	
21	FB4 - 2151 - 000		1	PLATE, FLAPPER PRESSURE フラッパ押し板	
22	FB4 - 2152 - 000		1	SPRING, TORSION ネジリ パネ	
23	FB4 - 2153 - 000		1	SPRING, TORSION ネジリ パネ	
24	FB4 - 2155 - 000		1	SPRING, TORSION ネジリ パネ	
25	FB4 - 2156 - 000		1	SPRING, TORSION ネジリ パネ	
26	FB4 - 2159 - 000		4	HOLDER, BUSHING 軸受ホルダ	
27	FB4 - 2164 - 000		1	COUPLING カップリング	
28	FB4 - 2325 - 000		2	BLOCK, GUIDE PRESSURE ガイド加圧ブロック	
29	FB4 - 7481 - 000		1	KNOB, DUPLEXING FEEDER 両面搬送ツマミ	

FIGURE & KEY NO.	PART NUMBER	RANK	QTY	DESCRIPTION	SERIAL NUMBER / REMARKS
360 - 30	FB4 - 7486 - 000		10	BUSHING ブッシング	
31	FB4 - 9035 - 000		1	PLATE, RETAINER 押さえ板	
32	FB5 - 6925 - 000		2	ROLLER, FEEDER 搬送ローラ	
33	FB6 - 0525 - 000		1	GUIDE, LEFT DECK, UPPER 左デッキ ガイド (上)	
34	FB6 - 0534 - 000		1	HOLDER, ROLLER コロ ホルダ	
35	FB6 - 0559 - 000		6	SPRING, TENSION ヒツバリ バネ	
36	FB6 - 0560 - 000		2	ROLLER, FEEDER 搬送ローラ (左)	
37	FB6 - 0567 - 000		1	PLATE, GROUNDING アース板	
38	FB6 - 0575 - 000		1	ROLLER, FEEDER 搬送ローラ	
39	FB6 - 0577 - 000		3	MOUNT, MOTOR モータ台	
40	FB6 - 0579 - 000		4	FLANGE, PULLEY プーリ フランジ	
41	FB6 - 0623 - 000		1	COVER, CABLE PROTECTIVE 束線保護カバー	
42	FB6 - 0624 - 000		1	COVER, GUIDE LOWER ガイド下カバー	
43	FB6 - 0625 - 000		1	GUIDE, DUPLEXING OUTLET 両面出口ガイド	
44	FB6 - 2397 - 000		4	ROLLER コロ	
45	FF5 - 7734 - 000		2	PLATE, LOCK ロック板	
46	FF5 - 7736 - 000		1	ROLLER, REVERSE, 1 反転ローラ (1)	
47	FF5 - 7737 - 020		2	PLATE, SENSOR SUPPORT センサ支板	
48	FF5 - 7948 - 000		1	PLATE, POSITIONING, FRONT 位置決め板 (前)	
49	FF5 - 7949 - 000		1	PLATE, POSITIONING, REAR 位置決め板 (後)	
50	FF5 - 8200 - 000		1	GUIDE, LOWER FEEDER, UPPER 下搬送ガイド (上)	
51	FF5 - 8201 - 000		1	GUIDE, REVERSING 反転ガイド	
52	FF5 - 8202 - 000		1	GUIDE, LEFT 左ガイド	
53	FF6 - 1519 - 000		1	ROLLER, REVERSE 反転ローラ	
54	FF6 - 1520 - 000		1	ROLLER, SPONGE, DUPLEXING 両面スポンジ ローラ	
55	FF6 - 1521 - 000		1	FRONT COVER, DUPLEXING 両面前カバー	
55 A	FS6 - 8704 - 000		1	LABEL, DUPLEXING UNIT NUMBER 両面ユニット番号ラベル	
56	FF6 - 1536 - 000		1	GUIDE, LEFT DECK, LOWER 左デッキ ガイド (下)	
57	FF6 - 1843 - 000		1	SUPPORT, FEEDER SENSOR 搬送センサ支板	
58	FF6 - 1858 - 000		1	MOUNT, REVERSE SENSOR 反転センサ台	

FIGURE & KEY NO.	PART NUMBER	RANK	QTY	DESCRIPTION	SERIAL NUMBER / REMARKS
360 - 59	FG6 - 1839 - 000		1	CABLE, DUPLEXING FEEDER 両面搬送束線	J326,327,330-334
59 A	VS1 - 5057 - 002		3	CONNECTOR, SNAP TIGHT チュウケイ コネクタ	J331-333
59 B	VS1 - 5057 - 003		1	CONNECTOR, SNAP TIGHT チュウケイ コネクタ	J334
59 C	VS1 - 5057 - 009		1	CONNECTOR, SNAP TIGHT チュウケイ コネクタ	J330
59 D	VS1 - 6318 - 003		1	CONNECTOR, SNAP TIGHT チュウケイ コネクタ	J326
60	FG6 - 1840 - 000		1	CABLE, CONFLUENT SENSOR 合流センサ中継束線	J336,337
60 A	VS1 - 5057 - 003		1	CONNECTOR, SNAP TIGHT チュウケイ コネクタ	J336
61	FG6 - 1841 - 000		1	CABLE, REGIST SENSOR CONNECT 横レジ センサ中継束線	J334,335
62	FG6 - 1843 - 000		1	CABLE, REVERSING SENSOR 反転センサ束線	J340,341
62 A	VS1 - 5057 - 003		1	CONNECTOR, SNAP TIGHT チュウケイ コネクタ	J340
63	FG6 - 8585 - 000		1	THROUGH-PATH PCB ASSEMBLY スルーパス回路基板	
64	FG6 - 8593 - 000		1	CABLE, DECK SENSOR CONNECTING デッキ引き抜きセンサ中継束線	J328,366
64 A	VS1 - 6318 - 004		1	CONNECTOR, SNAP TIGHT チュウケイ コネクタ	J366
65	FG6 - 8605 - 000		1	OPTICAL SENSOR PCB ASSEMBLY 光学センサ回路基板	PS26 J328
66	FG6 - 8616 - 000		1	CABLE, THROUGH-PATH DRAWER スルーパス ドロア束線	J322,323,326,329,330 J336,338,340,366,380
66 A	VS1 - 5057 - 006		1	CONNECTOR, SNAP TIGHT チュウケイ コネクタ	J381,3601-3603,3605 J3607-3609 J329
66 B	WT2 - 5565 - 000		5	CLAMP, CABLE ソクセン オサエ	
67	FG6 - 8617 - 000		1	CABLE, OUTLET SENSOR CONNECT 出口センサ中継束線	J338,339
67 A	VS1 - 5057 - 003		1	CONNECTOR, SNAP TIGHT チュウケイ コネクタ	J338
68	FG6 - 8618 - 000		1	CABLE, MOTOR CONNECTING モータ中継束線	J323-325,381,383
68 A	VS1 - 5057 - 003		2	CONNECTOR, SNAP TIGHT チュウケイ コネクタ	J381,383
69	FG6 - 8619 - 000		1	CABLE, MOTOR CONNECTING, 2 モータ中継束線 (2)	J380,382
70	FH6 - 1481 - 000		1	FAN, COOLING 冷却ファン	FM19 J383
71	FH6 - 1542 - 000		1	MOTOR, STEPPING, DC, 2.9W ステッピング モータ	M15 J329
72	FH6 - 1939 - 000		1	MOTOR, STEPPING ステッピング モータ	M11 J325
73	FH6 - 1940 - 000		2	MOTOR, STEPPING ステッピング モータ	M12,19 J324,382
74	FH6 - 5014 - 000		3	CLUTCH, ELECTROMAGNETIC 電磁クラッチ	CL16,17,19 J332,331,333
75	FH7 - 5837 - 000		1	SOLENOID ソレノイド	SL11 J3604
76	FH7 - 7196 - 020		1	PHOTO-INTERRUPTER フォトインタラプタ	PS18 J335

FIGURE & KEY NO.	PART NUMBER	RANK	QTY	DESCRIPTION	SERIAL NUMBER / REMARKS
360 - 77	FH7 - 7462 - 000		4	PHOTO-INTERRUPTER フォトインタラプタ	PS12,14,15,61 J341,327,337,339
78	FS1 - 1401 - 000		1	BUSHING ブッシング	
79	FS5 - 0338 - 000		1	GEAR, 16T 16T ギア	
80	FS5 - 0514 - 000		1	GEAR, 20T 20T ギア	
81	FS5 - 0710 - 000		1	GEAR, 16T 16T ギア	
82	FS5 - 0714 - 000		1	GEAR, 20T 20T ギア	
83	FS5 - 3314 - 000		3	PULLEY, 14T 14T プーリ	
84	FS5 - 3613 - 000		1	GEAR, 16T/24T 16T / 24T ギア	
85	FS5 - 3617 - 000		1	PULLEY, 30T 30T プーリ	
86	FS5 - 3942 - 000		1	GEAR, 18T/16T 18T / 16T ギア	
87	FS5 - 3943 - 000		3	PULLEY, 18T 18T プーリ	
88	FS5 - 3945 - 000		1	GEAR, 16T 16T ギア	
89	FS5 - 6487 - 000		7	SHIM ワッシャ	
90	FS5 - 6488 - 000		4	WASHER ワッシャ	
91	FS5 - 9221 - 000		1	SCREW,RS STEPPED,M3 RS タイト 段ビス	
92	FS6 - 0070 - 000		1	GEAR, 40T 40T ギア	
93	FS6 - 0145 - 000		1	GEAR, 16T 16T ギア	
94	FS6 - 0557 - 000		1	GEAR, 12T/36T 12T / 36T ギア	
95	FS6 - 2769 - 000		4	SPRING, COMPRESSION アッシュク バネ	
96	FS6 - 2770 - 000		1	SPRING, TENSION ヒツバリ バネ	
97	FS6 - 2771 - 000		2	SPRING, TENSION ヒツバリ バネ	
98	FS6 - 2772 - 000		2	SPRING, TENSION ヒツバリ バネ	
99	FS6 - 2773 - 000		2	SPRING, COMPRESSION アッシュク バネ	
100	FS6 - 2777 - 000		2	SPRING, TENSION ヒツバリ バネ	
101	FS6 - 2830 - 000		1	SPRING, TENSION ヒツバリ バネ	
102	FS6 - 2831 - 000		2	SPRING, TENSION ヒツバリ バネ	
103	FS6 - 2832 - 000		2	SPRING, COMPRESSION アッシュク バネ	
104	FS6 - 2980 - 000		1	SPRING, COMPRESSION アッシュク バネ	
105	FS6 - 2992 - 000		6	SPRING, COMPRESSION アッシュク バネ	
106	XA9 - 0249 - 000		1	SCREW,M4X8 ビス	

FIGURE & KEY NO.	PART NUMBER	R A N K	Q' T Y	DESCRIPTION	SERIAL NUMBER / REMARKS
360 - 107	XA9 - 0592 - 000		4	SCREW,M4X6 タイト ネジ	
108	XA9 - 0605 - 000		1	SCREW,M4X8 タイト ネジ	
109	XA9 - 0605 - 000		5	SCREW,M4X8 タイト ネジ	
110	XA9 - 0628 - 000		47	SCREW,RS,M4X8 RS タイト ネジ	
111	XA9 - 0899 - 000		1	SCREW,RS,M4X10 キクザツキ RS タイト ネジ	
112	XA9 - 0908 - 000		10	SCREW,RS,M4X8 RS タイト ネジ	
113	XF2 - 1611 - 080		2	BELT, TIMING タイミング ベルト	
114	XF2 - 1612 - 680		1	BELT, TIMING タイミング ベルト	
115	XF9 - 0663 - 000		1	BELT, TIMING タイミング ベルト	
116	XG2 - 8012 - 355		2	BEARING, BALL ボール ベアリング	
117	XG9 - 0192 - 000		1	BALL BEARING, NMB DDLF-1060ZZH ラジアル玉軸受	
118	XG9 - 0211 - 000		4	BALL BEARING, MF128ZZ1MC3D4M ボール ベアリング	
119	XG9 - 0249 - 000		8	BEARING, BALL ボール ベアリング	
120	XG9 - 0250 - 000		4	BEARING, BALL ボール ベアリング	
121	XG9 - 0291 - 000		2	BEARING, BALL ボール ベアリング	
122	XG9 - 0362 - 000		2	BEARING, BALL, DDL-1260ZZR ボール ベアリング	
501	XB1 - 2300 - 409		2	SCREW,MACH.,TRUSS HEAD,M3X4 バインド ネジ	
502	XB1 - 2300 - 409		4	SCREW,MACH.,TRUSS HEAD,M3X4 バインド ネジ	
503	XB1 - 2400 - 609		2	SCREW,MACH.,TRUSS HEAD,M4X6 バインド ネジ	
504	XB1 - 2400 - 609		19	SCREW,MACH.,TRUSS HEAD,M4X6 バインド ネジ	
505	XB1 - 2401 - 009		6	SCREW,MACH.,TRUSS HEAD,M4X10 バインド ネジ	
506	XB1 - 2402 - 009		2	SCREW,MACH.,TRUSS HEAD,M4X20 バインド ネジ	
507	XB2 - 7400 - 607		4	SCREW,W/WASHER,M4X6 パネツキ バインド ネジ	
508	XB2 - 8300 - 805		3	SCREW, MACH, PAN HEAD, M3X8 パネツキ バインド ネジ	
509	XB4 - 7300 - 809		1	SCREW,TAPPING,TRUSS HEAD,M3X8 バインド タッピン ネジ	
510	XB4 - 7301 - 209		1	SCREW,TAPPING,TRUSS HEAD,M3X12 バインド タッピン ネジ	
511	XB6 - 2400 - 509		6	SETSCREW,M4X5 ロツカク アナツキ トメネジ	
512	XD1 - 1104 - 139		1	SHIM ヒョウジュン ワッシャ	
513	XD1 - 1108 - 229		1	SHIM ヒョウジュン ワッシャ	
514	XD2 - 1100 - 502		2	RING,E E リング	

FIGURE & KEY NO.	PART NUMBER	R A N K	Q' T Y	DESCRIPTION	SERIAL NUMBER / REMARKS
360 - 515	XD2 - 1100 - 642		34	RING,E E リング	
516	XD3 - 1300 - 082		1	PIN,SPRING スプリング ピン	
517	XD3 - 2200 - 122		3	PIN,DOWEL ヘイコウ ピン	
518	XD3 - 2200 - 142		3	PIN,DOWEL ヘイコウ ピン	
519	XD3 - 2200 - 162		2	PIN,DOWEL ヘイコウ ピン	
520	XD3 - 2200 - 182		1	PIN,DOWEL ヘイコウ ピン	

FIGURE 420 MIRROR ASSEMBLY 1

第1ミラー台部

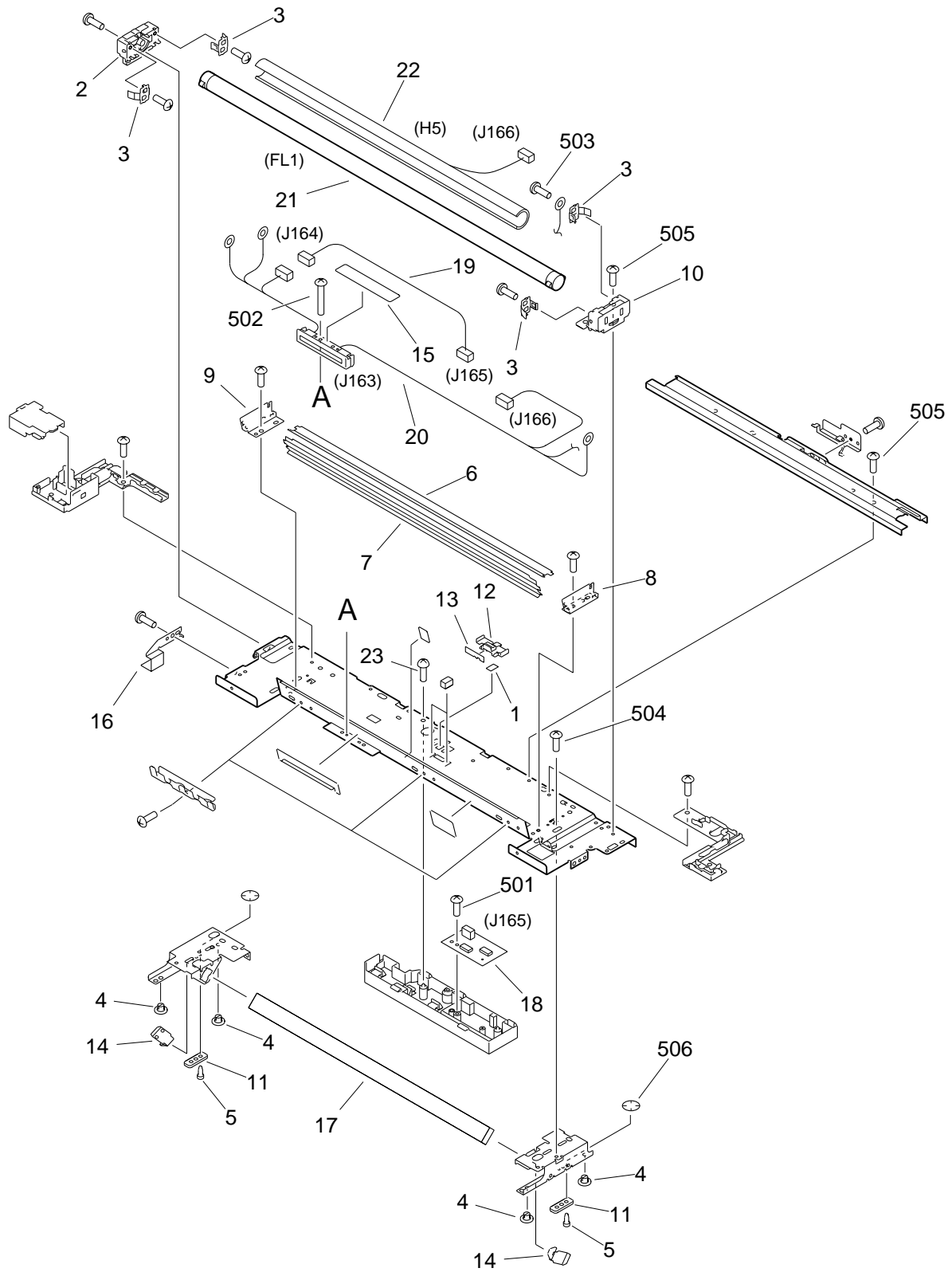

NOTE: This assembly does not include the part shown with key No. 15.
 注：このユニットにKey No. 15の部品は含まれません。

FIGURE & KEY NO.	PART NUMBER	R A N K	Q' T Y	DESCRIPTION	SERIAL NUMBER / REMARKS
420 -	FG6 - 2036 - 060		1	MIRROR ASSEMBLY 1 第1ミラー台部	
1	FB1 - 0715 - 000		1	ND FILTER 調光フィルタ	
2	FB2 - 1947 - 000		1	MOUNT, LAMP, FRONT ランプ支台 (前)	
3	FB2 - 1954 - 000		4	PLATE, CONTACT 電極パネ板	
4	FB3 - 2411 - 000		4	PIN, SLIDE スライド ピン	
5	FB3 - 7692 - 000		4	PIN, PAD, 2 パッド ピン (2)	
6	FB4 - 0786 - 000		1	REFLECTOR, LOWER 反射笠 (下)	
7	FB4 - 0787 - 000		1	REFLECTOR, AUXILIARY 補助反射笠	
8	FB4 - 0788 - 000		1	REFLECTOR, FRONT 反射笠 (前)	
9	FB4 - 0789 - 000		1	REFLECTOR, REAR 反射笠 (後)	
10	FB4 - 0795 - 000		1	MOUNT, TERMINAL 電極台	
11	FB4 - 0802 - 000		2	PAD, OIL オイル パッド	
12	FB4 - 0804 - 000		1	CAP, SENSOR 調光センサ キャップ	
13	FB4 - 0832 - 000		1	PLATE, LIGHT BLOCKING 調光キャップ遮光	
14	FB4 - 0864 - 000		2	SPRING, LEAF, MIRROR ミラー押えバネ	
15	FB4 - 0867 - 000		1	LABEL, "WARNING" サービス注意ラベル	SEE NOTE 100V
	FB4 - 0868 - 000		1	LABEL, "WARNING" サービス注意ラベル	SEE NOTE 208/220/240V
16	FB4 - 2385 - 000		1	FLAG, SENSOR センサ フラグ	
17	FF5 - 6579 - 000		1	MIRROR, 1 第1ミラー	
18	FG6 - 1943 - 000		1	EXPOSURE SENSOR PCB ASSEMBLY 調光センサ基板	J165
19	FG6 - 2326 - 000		1	CABLE, EXPOSURE SENSOR 調光センサ中継束線	J164,165
20	FH2 - 6453 - 000		1	CABLE, FLUORESCENT LAMP 蛍光灯束線	J163,164,166
21	FH7 - 3347 - 000		1	LAMP, FLUORESCENT 蛍光灯	FL1
22	FH7 - 4559 - 000		1	HEATER, FLUORESCENT LAMP 蛍光灯ヒータ	H5 J166
23	XA9 - 0596 - 000		1	SCREW,P,M3X6 P タイト ネジ	
501	XB1 - 2300 - 409		1	SCREW,MACH.,TRUSS HEAD,M3X4 バインド ネジ	
502	XB1 - 2301 - 209		2	SCREW,MACH.,TRUSS HEAD,M3X12 バインド ネジ	
503	XB2 - 8300 - 607		4	SCREW,W,WASHER,M3X6 パネツキ バインド ネジ	
504	XB2 - 8300 - 809		4	SCREW,W,WASHER,M3X8 パネツキ バインド ネジ	
505	XB6 - 7300 - 609		15	SCREW,TP,M3X6 TP ネジ	

FIGURE & KEY NO.	PART NUMBER	R A N K	Q' T Y	DESCRIPTION	SERIAL NUMBER / REMARKS
420 - 506	XD2 - 2300 - 202		4	RING,TOOTHED LOCK ハツキ トメワ	

FIGURE 430 MIRROR ASSEMBLY 2
第2ミラー台部

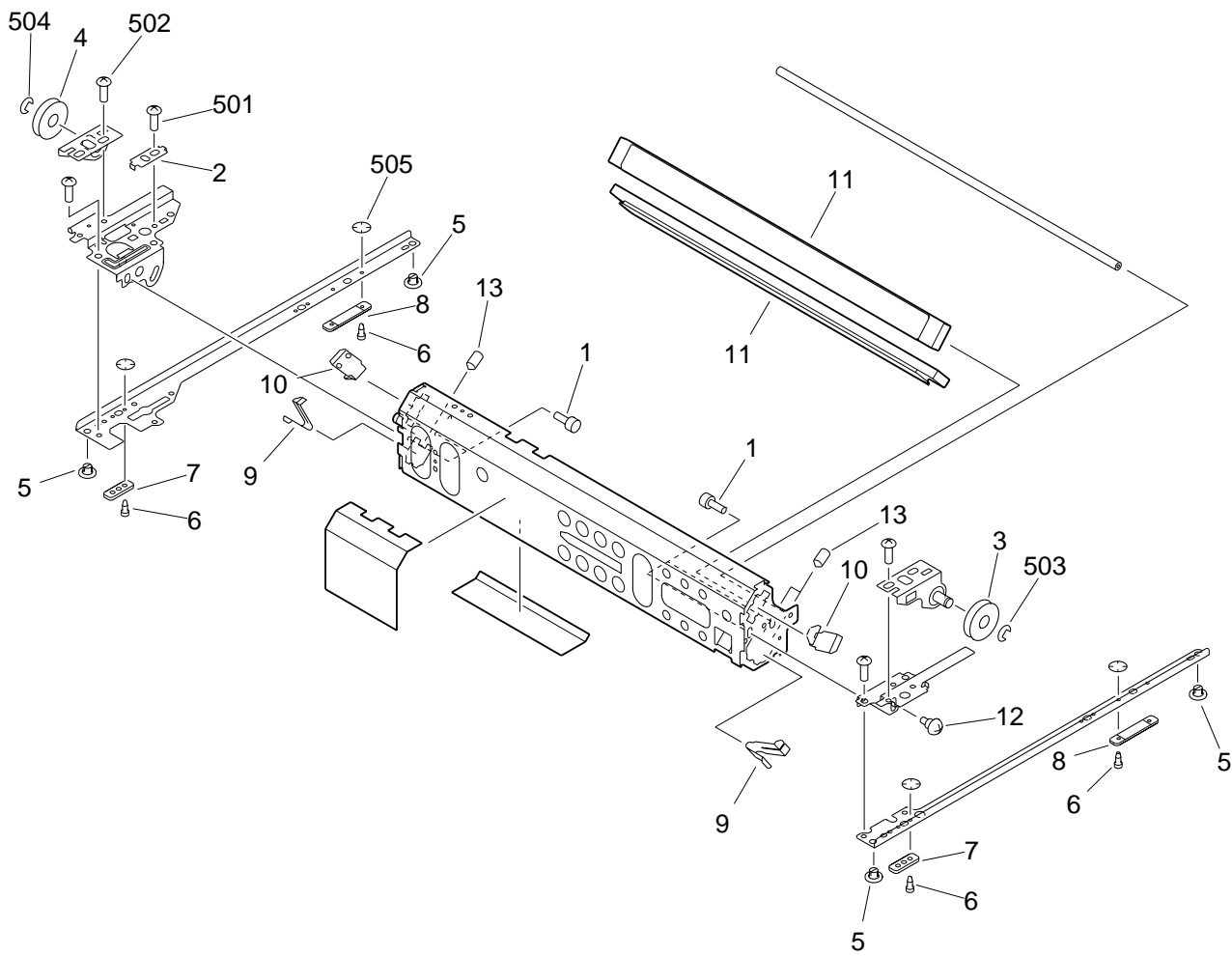
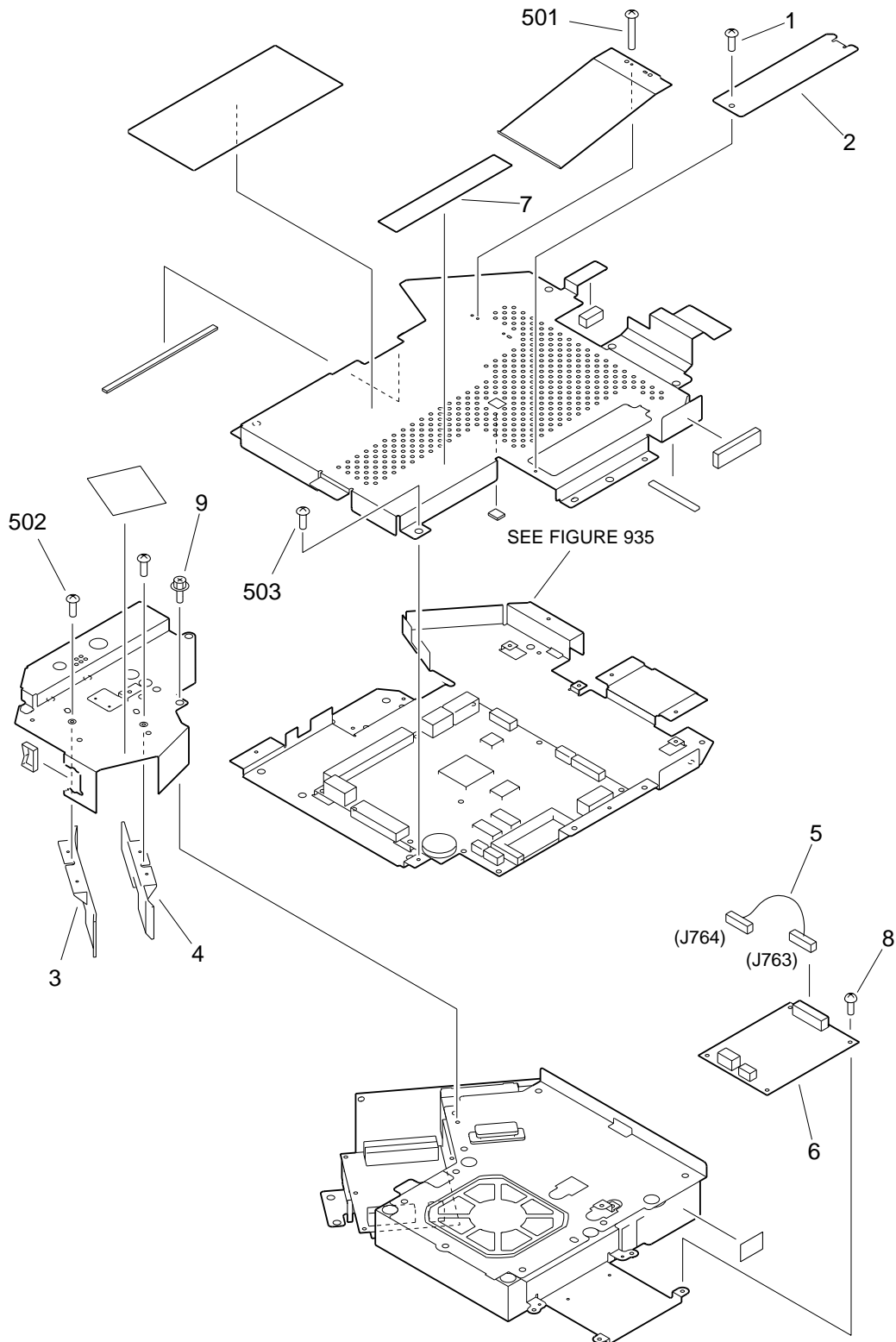

FIGURE & KEY NO.	PART NUMBER	R A N K	Q' T Y	DESCRIPTION	SERIAL NUMBER / REMARKS
430 -	FG6 - 4380 - 000		1	MIRROR ASSEMBLY 2 第2ミラー台部	
1	FA9 - 1990 - 000		4	SCREW, ALLEN HEAD, M3X6 ロッカク アナツキ ボルト	
2	FB1 - 6655 - 000		1	PLATE 直角板	
3	FB1 - 6663 - 000		1	PULLEY プ-リ	
4	FB1 - 6663 - 000		1	PULLEY プ-リ	
5	FB3 - 2411 - 000		4	PIN, SLIDE スライド ピン	
6	FB3 - 7692 - 000		8	PIN, PAD, 2 パッド ピン (2)	
7	FB4 - 0802 - 000		2	PAD, OIL オイル パッド	
8	FB4 - 0825 - 000		2	PAD, OIL, LEFT オイル パッド (左)	
9	FB4 - 0831 - 000		2	SPRING, LEAF 板バネ	
10	FB4 - 0864 - 000		2	SPRING, LEAF, MIRROR ミラー押えバネ	
11	FF5 - 6581 - 000		2	MIRROR, 2/3 第2 / 第3ミラー	
12	FS1 - 9009 - 000		2	SCREW, STEPPED, M3 ダンピス	
13	XA9 - 0425 - 000		3	SETSCREW, HEX SOCKET ロッカク アナツキ トメネジ	
501	XB1 - 2300 - 409		3	SCREW, MACH., TRUSS HEAD, M3X4 バインド ネジ	
502	XB6 - 7300 - 409		9	SCREW, TP, M3X4 TP ネジ	
503	XD2 - 1100 - 642		1	RING, E E リング	
504	XD2 - 1100 - 642		1	RING, E E リング	
505	XD2 - 2300 - 202		8	RING, TOOTHED LOCK ハツキ トメワ	

FIGURE 460 SCANNER ASSEMBLY スキャナ部



NOTE: This assembly does not include the parts shown with key No. 1, 2, 3, 4, 9, 501, 502 and 503.
 注: このユニットにKey No. 1, 2, 3, 4, 9, 501, 502, 503の部品は含まれません。

FIGURE & KEY NO.	PART NUMBER	RANK	QTY	DESCRIPTION	SERIAL NUMBER / REMARKS
460 -	FG6 - 8579 - 000		1	SCANNER ASSEMBLY スキャナ部	
1	FA9 - 1449 - 000		1	SCREW,W/WASHER,M3X6 パネツキ バインド ネジ	SEE NOTE
2	FB4 - 2347 - 000		1	COVER, ROM ROMカバー	SEE NOTE
3	FB5 - 7028 - 000		1	GUIDE, AIR, LEFT エア ガイド(左)	SEE NOTE
4	FB5 - 7029 - 000		1	GUIDE, AIR, RIGHT エア ガイド(右)	SEE NOTE
5	FG6 - 2340 - 000		1	CABLE, POLYGON MOTOR ポリゴン モータ束線	J763,764
6	FG6 - 8601 - 000		1	POLYGON MOTOR DRIVER PCB ASS'Y ポリゴン モータ ドライバ基板	
7	FS6 - 8820 - 000		1	LABEL, "WARNING LASER" レーザ注意ラベル	100/208V
	FS5 - 8623 - 000		1	LABEL, "WARNING LASER" レーザ注意ラベル	220/240V
8	XA9 - 0385 - 000		6	SCREW, W/WASHER, TRUSS HEAD パネツキ ネジ	
9	XA9 - 0643 - 000		4	SCREW,RS,M4X10 RS タイト ネジ	SEE NOTE
501	XB1 - 2301 - 209		2	SCREW,MACH.,TRUSS HEAD,M3X12 バインド ネジ	SEE NOTE
502	XB1 - 2400 - 609		2	SCREW,MACH.,TRUSS HEAD,M4X6 バインド ネジ	SEE NOTE
503	XB2 - 7400 - 607		6	SCREW,W/WASHER,M4X6 パネツキ バインド ネジ	SEE NOTE

FIGURE 510 PHOTO-SENSITIVE DRUM ASSEMBLY 感光ドラム部

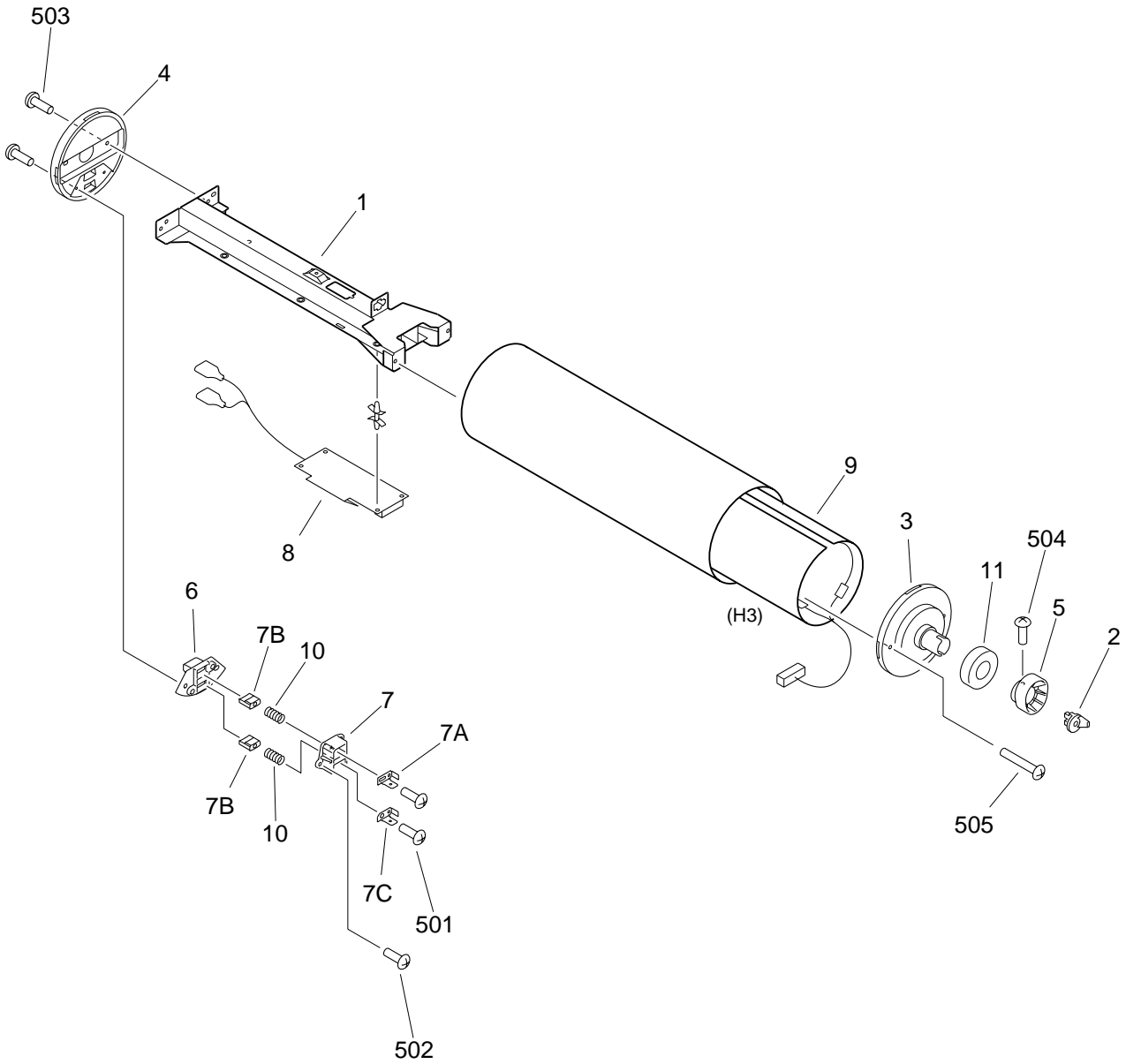
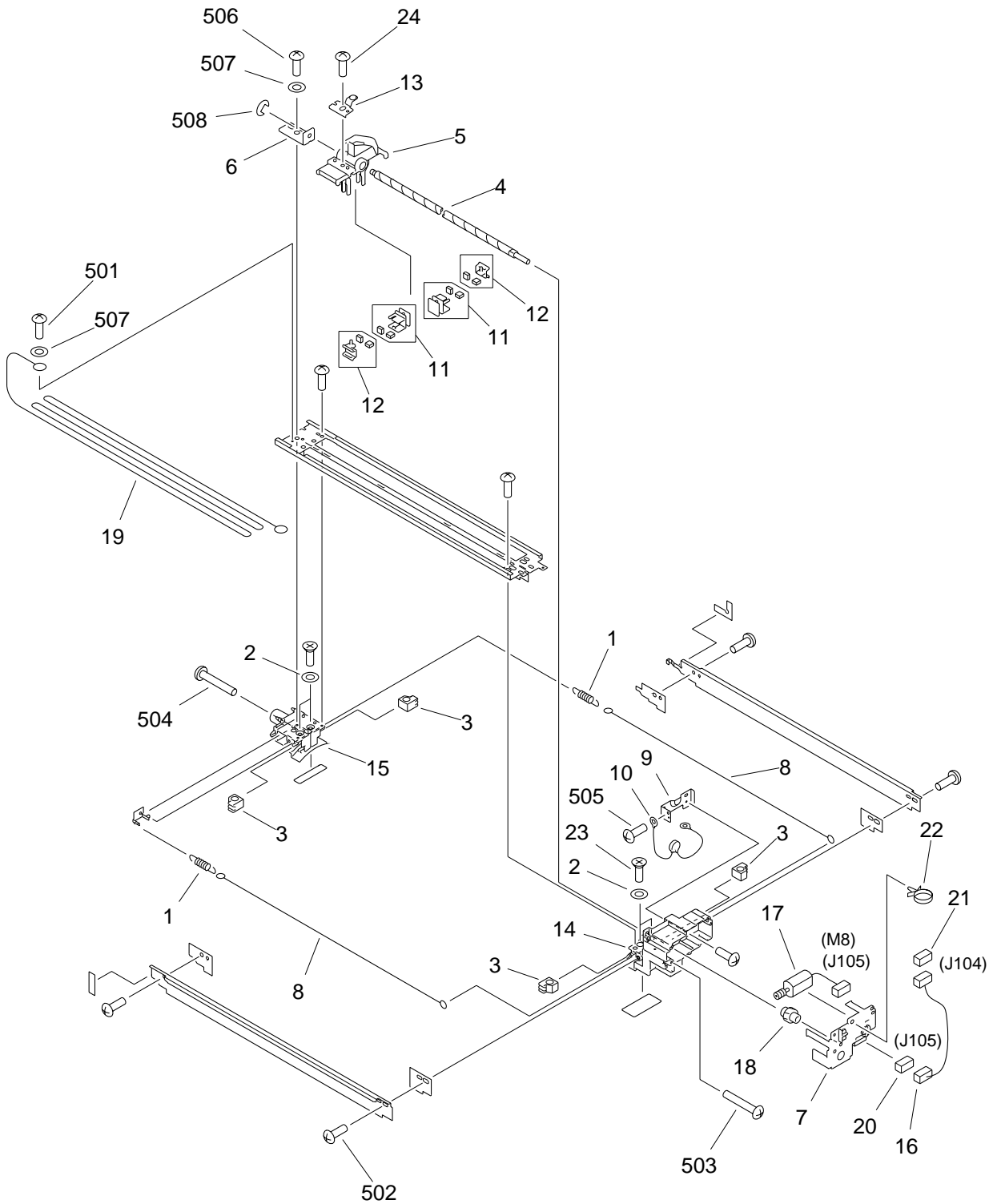

FIGURE & KEY NO.	PART NUMBER	RANK	QTY	DESCRIPTION	SERIAL NUMBER / REMARKS
510 -	NPN		RF	PHOTO-SENSITIVE DRUM ASSEMBLY 感光ドラム部	
1	FA6 - 0648 - 000		1	GUIDE, DRUM ドラム ガイド	
2	FB4 - 1416 - 000		1	SUPPORT, DRUM ドラム固定筒	
3	FB4 - 1620 - 000		1	FLANGE, DRUM, FRONT ドラム フランジ (前)	
4	FB4 - 1621 - 000		1	FLANGE, DRUM, REAR ドラム フランジ (後)	
5	FB4 - 1622 - 000		1	CAM カム	
6	FB4 - 1623 - 000		1	MOUNT, BRUSH 摺電ブラシ台	
7	FF5 - 8733 - 000		1	BLOCK, TERMINAL 端子台	
7 A	FA3 - 2394 - 000		1	TERMINAL, 1 摺電ブラシ端子 (1)	
7 B	FA3 - 2395 - 000		2	BRUSH 摺電ブラシ	
7 C	FB3 - 6117 - 000		1	TERMINAL, 2 摺電ブラシ端子 (2)	
8	FH6 - 3994 - 000		1	HEATER CONTROL PCB ASSEMBLY ヒータ制御回路基板	
9	FH7 - 4714 - 000		1	HEATER, DRUM ドラム ヒータ	200/208V H3
	FH7 - 4715 - 000		1	HEATER, DRUM ドラム ヒータ	220/240V H3
10	FS2 - 2036 - 020		2	SPRING, COMPRESSION アッシュク バネ	
11	XG9 - 0307 - 000		1	BEARING, BALL ボール ベアリング	
501	XA1 - 6260 - 409		2	SCREW, M2, 6X4 ナベ ネジ	
502	XB1 - 2300 - 609		2	SCREW, MACH., TRUSS HEAD, M3X6 バインド ネジ	
503	XB1 - 2400 - 609		4	SCREW, MACH., TRUSS HEAD, M4X6 バインド ネジ	
504	XB2 - 8400 - 809		1	SCREW, W/WASHER, M4X8 パネツキ バインド ネジ	
505	XB6 - 7401 - 609		2	SCREW, TP, M4X16 TP ネジ	

FIGURE 550 PRIMARY CORONA ASSEMBLY 一次帯電器



NOTE: This assembly does not include the part shown with key No. 21.

注：このユニットにKey No. 21の部品は含まれません。

FIGURE & KEY NO.	PART NUMBER	RANK	QTY	DESCRIPTION	SERIAL NUMBER / REMARKS
550 -	FG6 - 7313 - 000		1	PRIMARY CORONA ASSEMBLY 一次帯電器	
1	97 - 5527 - 000		2	SPRING, TENSION 帯電線ヒツバリ パネ	
2	FA2 - 1498 - 000		4	WASHER ワッシャ	
3	FA3 - 2118 - 000		4	GUIDE, CORONA WIRE 帯電線ガイド	
4	FB4 - 1693 - 000		1	SCREW, SHAFT リード ネジ	
5	FB4 - 1933 - 000		1	HOLDER, PRIMARY CORONA クリップ台	
6	FB4 - 1940 - 000		1	PLATE, SHAFT SCREW リード ネジ板	
7	FB4 - 1941 - 000		1	COVER, MOTOR モータ カバー	
8	FB4 - 3687 - 000		AR	WIRE, CORONA, 0.06MM (20M) 帯電線	
9	FB4 - 5305 - 000		1	PLATE, HEIGHT ADJUSTING 高さ調整板	
10	FF3 - 3330 - 000		1	VARISTOR UNIT バリスタ ユニット	
11	FF5 - 6883 - 000		2	BLOCK, WIRE CLEANING PAD 帯電線清掃パッド ブロック	
12	FF5 - 6884 - 000		2	BLOCK, WIRE CLEANING PAD 帯電線清掃パッド ブロック	
13	FF5 - 6885 - 000		1	GUIDE, PIN ピン ガイド	
14	FF5 - 7705 - 000		1	BLOCK, PRIMARY CORONA, FRONT 一次帯電器ブロック (前)	
15	FF5 - 7706 - 000		1	BLOCK, PRIMARY CORONA, REAR 一次帯電器ブロック (後)	
16	FG6 - 1858 - 000		1	CABLE, MOTOR CONNECTING モータ中継束線	J104,105
17	FH6 - 1135 - 000		1	MOTOR, DC, 1.36W DCモータ	M8 J105
18	FS6 - 0115 - 000		1	GEAR, 18T 18T ギア	
19	FY1 - 0883 - 000		AR	WIRE, GRID, 0.1MM (100M) グリッド ワイヤ	
20	VS1 - 5057 - 002		1	CONNECTOR, SNAP TIGHT チュウケイ コネクタ	J105
21	VS1 - 5057 - 002		1	CONNECTOR, SNAP TIGHT チュウケイ コネクタ	SEE NOTE J104
22	WT2 - 5178 - 000		1	CLIP, CABLE ロッキング ワイヤ サドル	
23	XA9 - 0228 - 000		4	SCREW, MACH., C.S. HEAD, M4X18 サラ ネジ	
24	XA9 - 0915 - 000		3	SCREW, M3X6 タイト ネジ	
501	XB1 - 2300 - 603		1	SCREW, MACH., TRUSS HEAD, M3X6 バインド ネジ	
502	XB1 - 2300 - 609		12	SCREW, MACH., TRUSS HEAD, M3X6 バインド ネジ	
503	XB1 - 2301 - 207		1	SCREW, MACH., TRUSS HEAD, M3X12 バインド ネジ	
504	XB1 - 2302 - 503		1	SCREW, MACH., TRUSS HEAD, M3X25 バインド ネジ	
505	XB2 - 7300 - 607		2	SCREW, W/WASHER, M3X6 パネツキ バインド ネジ	

FIGURE & KEY NO.	PART NUMBER	R A N K	Q' T Y	DESCRIPTION	SERIAL NUMBER / REMARKS
550 - 506	XB6 - 7300 - 609		1	SCREW,TP,M3X6 TP ネジ	
507	XD1 - 2100 - 307		1	WASHER,PLAIN ヒラ ザガネ	
508	XD2 - 1100 - 242		1	RING,E E リンゲ	

FIGURE 570 PRE-TRANSFER CORONA ASSEMBLY
 転写前帯電器

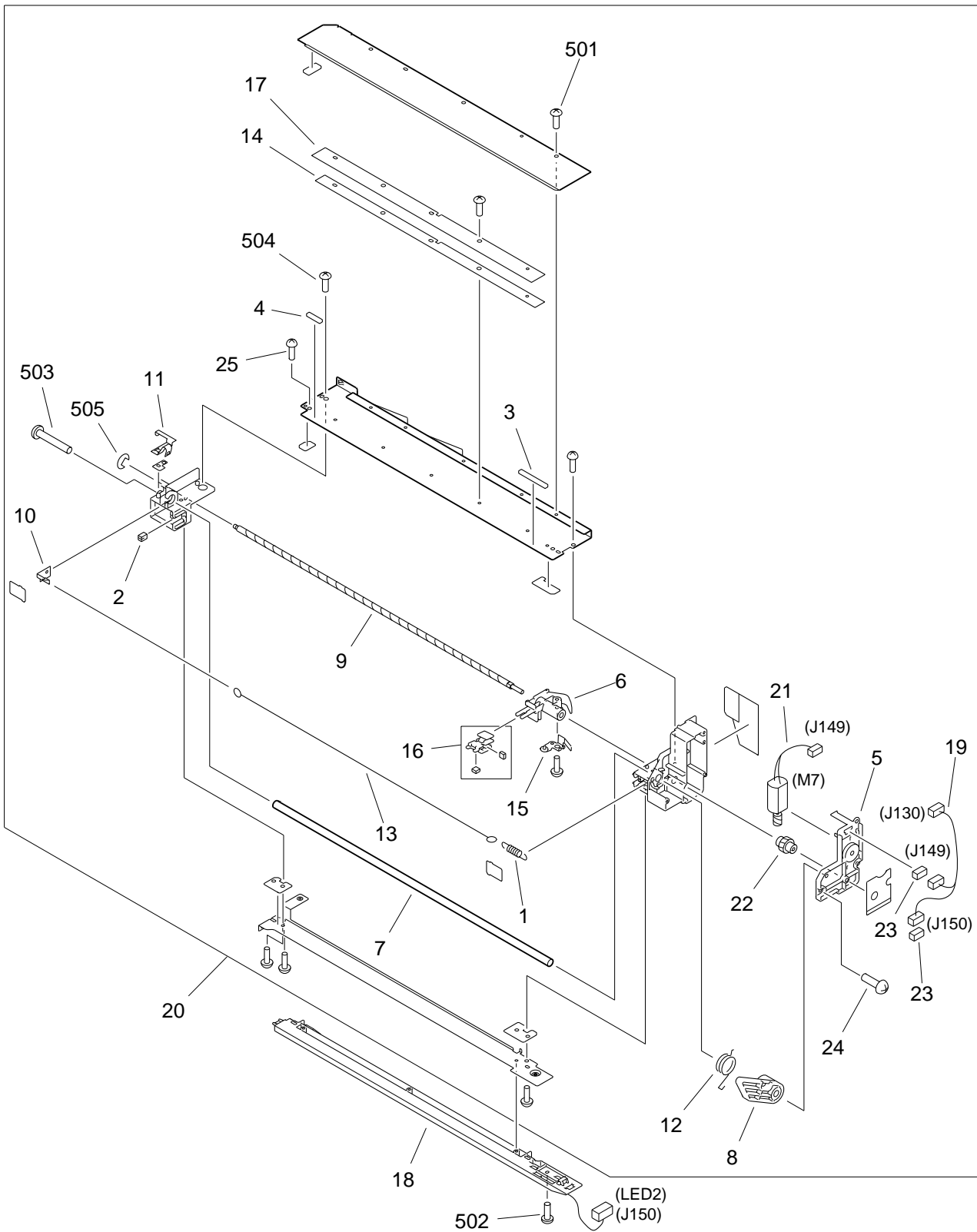

FIGURE & KEY NO.	PART NUMBER	RANK	QTY	DESCRIPTION	SERIAL NUMBER / REMARKS
570 -	FG6 - 7424 - 000		1	PRE-TRANSFER CORONA ASSEMBLY 転写前帯電器	
1	97 - 5527 - 000		1	SPRING, TENSION 帯電線ヒツバリ バネ	
2	FA3 - 2128 - 000		1	DAMPER パッド	
3	FA3 - 2565 - 000		1	BRUSH, FRONT バイアス ブラシ (前)	
4	FA3 - 8004 - 000		1	BRUSH, REAR バイアス ブラシ (後)	
5	FB4 - 1680 - 020		1	COVER, PRE-TRANSFER MOTOR 転写前モータ カバー	
6	FB4 - 1681 - 020		1	HOLDER, SHAFT SCREW リード ネジ ホルダ	
7	FB4 - 1682 - 000		1	ROLLER, BIAS バイアス ローラ	
8	FB4 - 1683 - 000		1	ARM, BIAS ROLLER バイアス ローラ アーム	
9	FB4 - 1693 - 000		1	SCREW, SHAFT リード ネジ	
10	FB4 - 1694 - 000		1	TERMINAL, CORONA 帯電電極	
11	FB4 - 1695 - 000		1	TERMINAL, BIAS ROLLER バイアス ローラ電極	
12	FB4 - 1696 - 000		1	SPRING, TORSION ネジリ バネ	
13	FB4 - 3687 - 000		AR	WIRE, CORONA, 0.06MM (20M) 帯電線	
14	FB5 - 9354 - 000		1	PLATE, SCRAPER RETAINING スクレーパ押え板	
15	FF5 - 2942 - 020		1	PLATE, PRESSURE 加圧板	
16	FF5 - 9552 - 000		1	CLEANER, WIRE ワイヤ クリーナ	
17	FF6 - 1031 - 000		1	MOUNT, PRE-TRANSFER SCRAPER 転写前スクレーパ	
18	FG6 - 7185 - 000		1	PRE-TRANSFER EXPOSURE UNIT 転写露光ユニット	LED2 J150
19	FG6 - 7203 - 000		1	CABLE, PRE-TRANSFER CONNECTING 転写前中継束線	J130,149,150
20	FG9 - 3863 - 000		1	PRE-TRANSFER SUB UNIT 転写前サブ ユニット	
21	FH6 - 1135 - 000		1	MOTOR, DC, 1.36W DCモータ	M7 J149
22	FS6 - 0115 - 000		1	GEAR, 18T 18T ギア	
23	VS1 - 5057 - 002		2	CONNECTOR, SNAP TIGHT チュウケイ コネクタ	J149,150
24	XA9 - 0591 - 000		2	SCREW,M3X8 タイト ネジ	
25	XA9 - 0596 - 000		6	SCREW,P,M3X6 P タイト ネジ	
501	XB1 - 2300 - 407		8	SCREW,MACH.,TRUSS HEAD,M3X4 バインド ネジ	
502	XB1 - 2300 - 609		1	SCREW,MACH.,TRUSS HEAD,M3X6 バインド ネジ	
503	XB1 - 2301 - 603		1	SCREW,MACH.,TRUSS HEAD,M3X16 バインド ネジ	
504	XB1 - 2400 - 407		1	SCREW,MACH.,TRUSS HEAD,M4X4 バインド ネジ	

FIGURE & KEY NO.	PART NUMBER	R A N K	Q' T Y	DESCRIPTION	SERIAL NUMBER / REMARKS
570 - 505	XD2 - 1100 - 242		1	RINGE E リング	

FIGURE 580 TRANSFER/SEPARATE CORONA ASSEMBLY

転写 / 分離帯電器

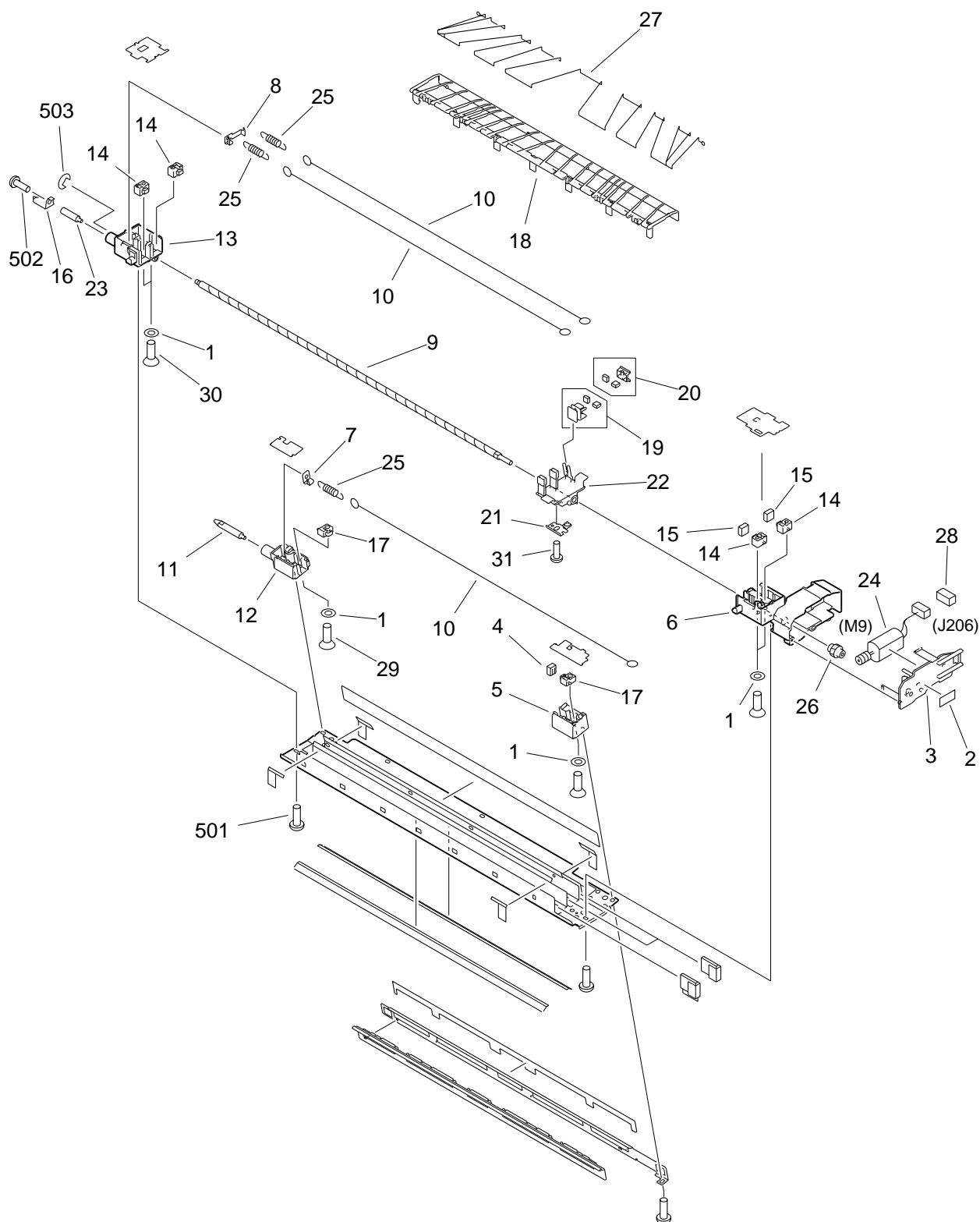
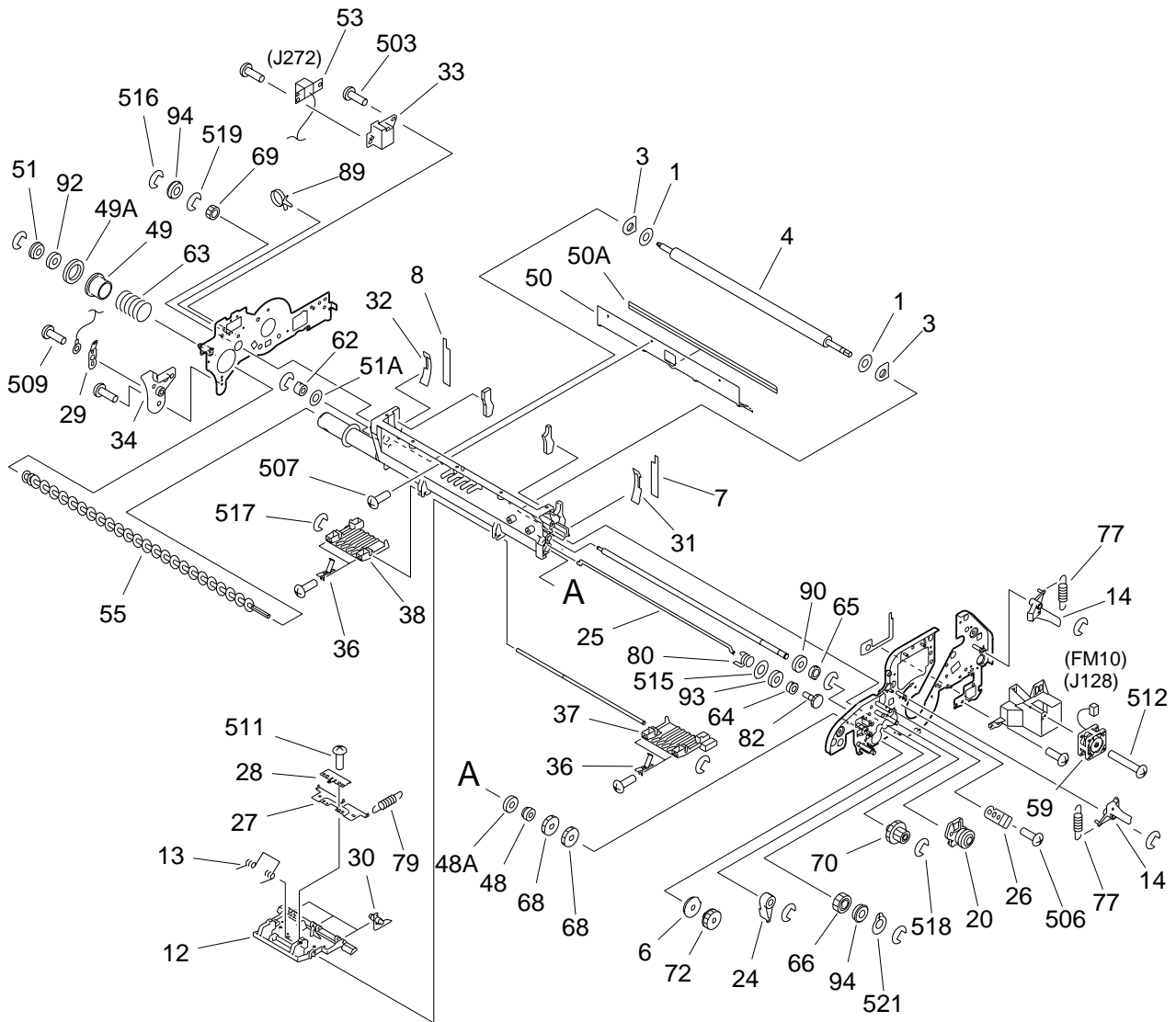

FIGURE & KEY NO.	PART NUMBER	RANK	QTY	DESCRIPTION	SERIAL NUMBER / REMARKS
580 -	FG6 - 8733 - 000		1	TRANSFER/SEPARATE CORONA ASS'Y 転写 / 分離帯電器	
1	FA2 - 1498 - 000		6	WASHER ワッシャ	
2	FA9 - 3822 - 000		1	LABEL, DISCRIMINATE 識別ラベル	
3	FB2 - 6850 - 000		1	COVER, MOTOR モ - タ カバ -	
4	FB2 - 7096 - 000		3	PAD, DUST-PROOF 防塵パッド	
5	FB4 - 1648 - 000		1	BLOCK, TRANSFER, FRONT 転写ブロック (前)	
6	FB4 - 1650 - 000		1	BLOCK, SEPARATION, FRONT 分離ブロック (前)	
7	FB4 - 1656 - 000		1	HOOK, SPRING, 1 バネ掛け (1)	
8	FB4 - 1657 - 000		1	HOOK, SPRING, 2 バネ掛け (2)	
9	FB4 - 1693 - 000		1	SCREW, SHAFT リード ネジ	
10	FB4 - 3687 - 000		AR	WIRE, CORONA, 0.06MM (20M) 帯電線	
11	FB4 - 9355 - 000		1	PIN, TRANSFER/SEPARATION 転写 / 分離ピン	
12	FB5 - 0529 - 000		1	BLOCK, TRANSFER, REAR 転写ブロック (後)	
13	FB5 - 0530 - 000		1	BLOCK, SEPARATION, REAR 分離ブロック (後)	
14	FB5 - 2394 - 000		4	BLOCK, ADJUSTING 調整コマ	
15	FB5 - 2515 - 000		2	PAD, CUSHION 防振パッド	
16	FB5 - 3105 - 000		1	TERMINAL, TRANSFER/SEPARATION 転写 / 分離接点板	
17	FB5 - 9648 - 000		2	GUIDE, CORONA WIRE 高さ調整コマ	
18	FB6 - 0502 - 000		1	GUIDE, PAPER SEPARATION 分離紙ガイド	
19	FF5 - 6883 - 000		1	BLOCK, WIRE CLEANING PAD 帯電線清掃パッド ブロック	
20	FF5 - 6884 - 000		1	BLOCK, WIRE CLEANING PAD 帯電線清掃パッド ブロック	
21	FF5 - 6885 - 000		1	GUIDE, PIN ピン ガイド	
22	FF5 - 7891 - 020		1	HOLDER, FELT フェルト ホルダ	
23	FH2 - 9242 - 000		1	PIN, RESISTANCE 抵抗ピン	
24	FH6 - 1135 - 000		1	MOTOR, DC, 1.36W DCモ - タ	M9 J206
25	FS2 - 2551 - 000		3	SPRING, TENSION ヒツパリ バネ	
26	FS6 - 0115 - 000		1	GEAR, 18T 18T ギア	
27	RY1 - 1502 - 000		AR	WIRE, GUIDE テグス線	
28	VS1 - 5057 - 002		1	CONNECTOR, SNAP TIGHT チュウケイ コネクタ	J206
29	XA9 - 0034 - 000		2	SCREW, MACH., C.S. HEAD, M4X15 サラ ネジ	

FIGURE & KEY NO.	PART NUMBER	R A N K	Q' T Y	DESCRIPTION	SERIAL NUMBER / REMARKS
580 - 30	XA9 - 0228 - 000		4	SCREW,MACH.,C.S.HEAD,M4X18 サラ ネジ	
31	XA9 - 0915 - 000		1	SCREW,M3X6 タイト ネジ	
501	XB1 - 2300 - 609		8	SCREW,MACH.,TRUSS HEAD,M3X6 バインド ネジ	
502	XB2 - 7300 - 607		1	SCREW,W/WASHER,M3X6 パネツキ バインド ネジ	
503	XD2 - 1100 - 242		1	RING,E E リング	

FIGURE 600 AP KIT ASSEMBLY(1/2)
APキット部(1/2)



NOTE1: This assembly includes the assembly shown in Figure 720.

NOTE2: This assembly does not include the parts shown with key No. 10, 19, 26, and 506.

注1: このユニットはFigure720のユニットを含みます。

注2: このユニットにKey No. 10、19、26、506の部品は含まれません。

FIGURE 600 AP KIT ASSEMBLY(2/2)
 APキット部(2/2)

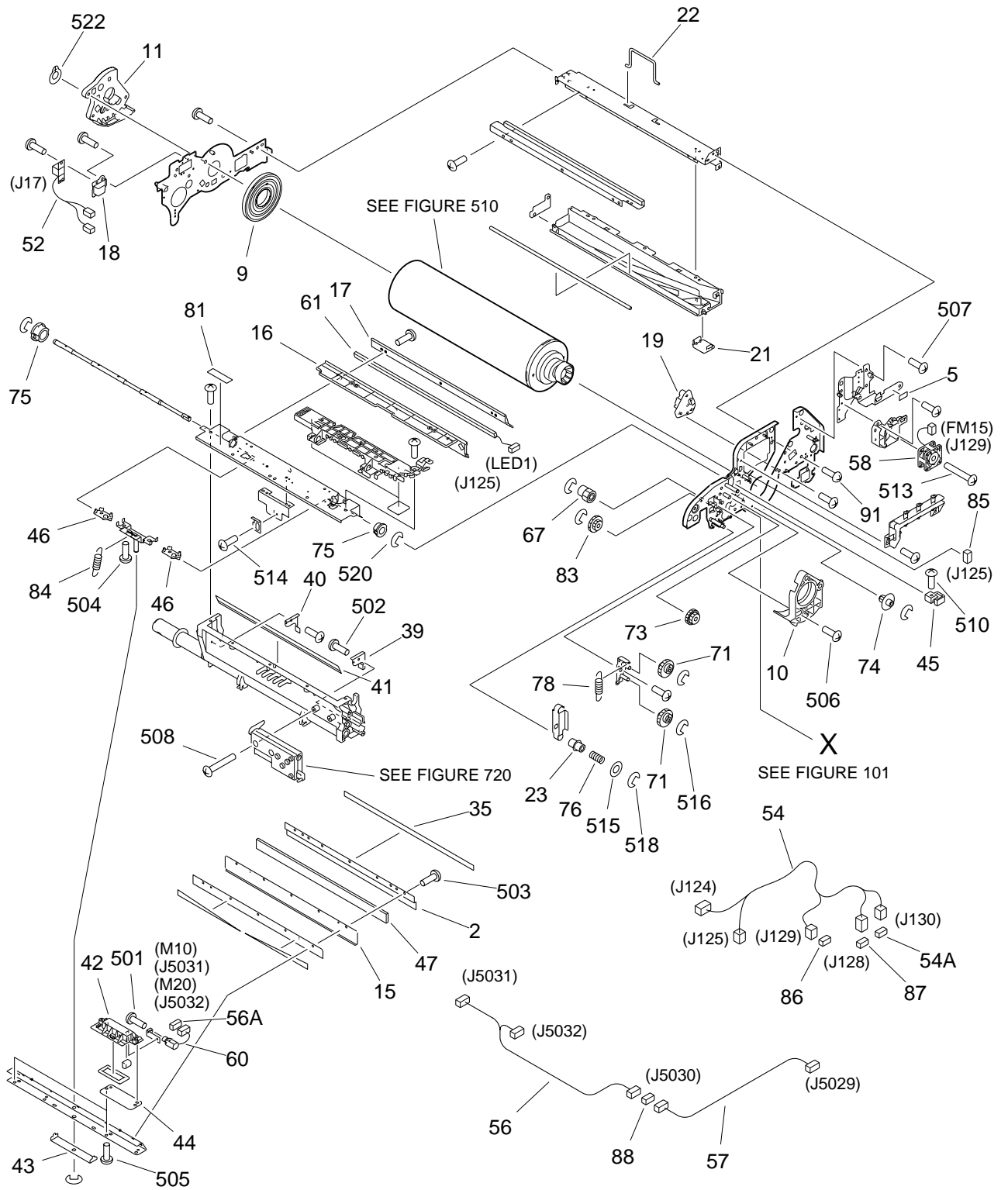

FIGURE & KEY NO.	PART NUMBER	RANK	QTY	DESCRIPTION	SERIAL NUMBER / REMARKS
600 -	FG6 - 8724 - 000		1	AP KIT ASSEMBLY APキット部	SEE NOTE 1
1	FA4 - 1819 - 000		2	SPACER スペーサ	
2	FA4 - 2037 - 000		1	RETAINER, BLADE ブレード オサエ	
3	FA6 - 7865 - 000		2	SEAL, FELT シール フェルト	
4	FA9 - 3730 - 000		1	ROLLER, MAGNET マグネット ローラ	
5	FA9 - 3822 - 000		1	LABEL, DISCRIMINATE 識別ラベル	
6	FB2 - 8302 - 000		1	BUSHING ブッシング	
7	FB4 - 1569 - 000		1	SEAL, SIDE, FRONT サイド シール (前)	
8	FB4 - 1570 - 000		1	SEAL, SIDE, REAR サイド シール (後)	
9	FB4 - 1575 - 000		1	SUPPORT, DRUM SIDE ドラム サイド押え	
10	FB4 - 1576 - 000		1	BLOCK, TRANSFER FIXING, FRONT 転写固定ブロック (前)	SEE NOTE 2
11	FB4 - 1577 - 000		1	BLOCK, TRANSFER FIXING, REAR 転写固定ブロック (後)	
12	FB4 - 1584 - 000		1	HOLDER, CLAW 爪ホルダ	
13	FB4 - 1585 - 000		1	SPRING, TORSION ネジリ バネ	
14	FB4 - 1590 - 000		2	SUPPORT, CORONA FIXING 帯電器固定板	
15	FB4 - 1592 - 000		1	PLATE, BLADE BACKING ブレード背板	
16	FB4 - 1594 - 000		1	HOLDER, PRECONDITIONING, A 前露光ホルダ (A)	
17	FB4 - 1595 - 000		1	HOLDER, PRECONDITIONING, B 前露光ホルダ (B)	
18	FB4 - 1600 - 000		1	HOLDER, CONNECTOR コネクタ ホルダ	
19	FB4 - 1607 - 000		1	HOLDER, POSITIONING, FRONT 位置決めホルダ (前)	SEE NOTE 2
20	FB4 - 1609 - 000		1	LIMITER, TORQUE トルク リミッタ	
21	FB4 - 1611 - 000		1	COVER, PRE-TRANSFER DUCT 転写前ダクト カバー	
22	FB4 - 1612 - 000		1	HANDLE 把手	
23	FB4 - 1613 - 000		1	SPACER スペーサ	
24	FB4 - 1617 - 000		1	ARM, ROLLER ローラ アーム	
25	FB4 - 1618 - 000		1	SHAFT, CLEANER STIRRING クリーナ攪拌棒	SEE NOTE 2
26	FB4 - 1619 - 000		1	RETAINER, BEARING ベアリング押え	
27	FB4 - 8012 - 000		1	PLATE, SEPARATION CLAW 分離爪プレート	
28	FB4 - 8013 - 000		1	PLATE, GROUNDING, 1 アース板 (1)	
29	FB4 - 8014 - 000		1	PLATE, GROUNDING, 2 アース板 (2)	

FIGURE & KEY NO.	PART NUMBER	RANK	QTY	DESCRIPTION	SERIAL NUMBER / REMARKS
600 - 30	FB4 - 8018 - 000		3	CLAW, SEPARATION 分離爪	
31	FB4 - 9517 - 000		1	PLATE, SHEET SUPPORT, FRONT シート保護板(前)	
32	FB4 - 9518 - 000		1	PLATE, SHEET SUPPORT, REAR シート保護板(後)	
33	FB4 - 9525 - 000		1	HOLDER, CONNECTOR コネクタホルダ	
34	FB4 - 9526 - 000		1	HOLDER, BIAS SUPPORT バイアス支持ホルダ	
35	FB5 - 1844 - 000		1	LABEL, "CAUTION, BLADE CHANGE" ブレード交換注意ラベル	
36	FB5 - 2598 - 000		4	PLATE, HOLDER SUPPORT ホルダ支持板	
37	FB5 - 6856 - 000		1	GUIDE, CLEANER COOLING, FRONT クリーナ冷却ガイド(前)	
38	FB5 - 6857 - 000		1	GUIDE, CLEANER COOLING, REAR クリーナ冷却ガイド(後)	
39	FB5 - 6868 - 000		1	SCRAPER, FRONT スクレーパ(前)	
40	FB5 - 6869 - 000		1	SCRAPER, REAR スクレーパ(後)	
41	FB5 - 8817 - 000		1	SHEET, SCRAPER, LOWER スクレーパシート(下)	
42	FB6 - 2380 - 000		2	HOUSING, MOTOR モータハウジング	
43	FB6 - 2385 - 000		1	SPRING, LEAF 板バネ	
44	FB6 - 2390 - 000		2	COVER, MOTOR モータカバー	
45	FB6 - 2400 - 000		1	ARM, RECIPROCATING レシプロアーム	
46	FB6 - 2402 - 000		2	RETAINER, SWING PLATE 揺動板押さえ	
47	FB6 - 2720 - 000		1	BLADE, CLEANING クリーニングブレード	
48	FF2 - 2891 - 000		1	BUSHING ブッシング	
48 A	XG9 - 0111 - 000		1	SEAL, OIL オイルシール	
49	FF5 - 2986 - 000		1	SHUTTER, WASTE TONER ハイトナシャッタ	
49 A	FB2 - 6897 - 000		1	SEAL, SHUTTER シャッタシール	
50	FF5 - 7682 - 000		1	SCRAPER スクレーパ	
50 A	FB4 - 1616 - 000		1	SHEET, SCRAPER スクレーパシート	
51	FF6 - 1016 - 000		1	BUSHING ブッシング	
51 A	XG9 - 0143 - 000		1	SEAL, OIL オイルシール	
52	FG6 - 1853 - 000		1	CABLE, DRUM HEATER ドラムヒータ中継束線	J17
53	FG6 - 3568 - 000		1	CABLE, SEPARATION CLAW 分離爪束線	J272
54	FG6 - 7204 - 000		1	CABLE, AP KIT APキット束線	J124,125,128-130
54 A	VS1 - 5057 - 004		1	CONNECTOR, SNAP TIGHT チュウケイコネクタ	J130

FIGURE & KEY NO.	PART NUMBER	R A N K	Q' T Y	DESCRIPTION	SERIAL NUMBER / REMARKS
600 - 55	FG6 - 7429 - 000		1	SCREW, CLEANING クリーナ スクリュ	
56	FG6 - 8594 - 000		1	CABLE, VIB. MOTOR CONNECT, 1 パイプレーション モータ中継束線 (1)	J5030-5032
56 A	VS1 - 5057 - 002		2	CONNECTOR, SNAP TIGHT チュウケイ コネクタ	J5031,5032
57	FG6 - 8595 - 000		1	CABLE, VIB. MOTOR CONNECT, 2 パイプレーション モータ中継束線 (2)	J5029,5030
58	FH6 - 1547 - 000		1	FAN, COOLING 冷却ファン	FM15 J129
59	FH6 - 1547 - 000		1	FAN, COOLING 冷却ファン	FM10 J128
60	FH6 - 1961 - 000		2	MOTOR, DC DCモータ	M10,20 J5031,5032
61	FH7 - 3395 - 000		1	LED ARRAY UNIT LEDアレイ ユニット	LED1 J125
62	FS2 - 1463 - 000		1	BUSHING ブッシング	
63	FS3 - 2887 - 000		1	SPRING, COMPRESSION アッシュク バネ	
64	FS5 - 1800 - 000		1	BUSHING ブッシング	
65	FS5 - 1801 - 000		1	BUSHING ブッシング	
66	FS6 - 0121 - 000		1	GEAR, 14T 14T ギア	
67	FS6 - 0136 - 000		1	GEAR, 18T 18T ギア	
68	FS6 - 0138 - 000		2	GEAR, 30T 30T ギア	
69	FS6 - 0972 - 000		1	GEAR, 14T 14T ギア	
70	FS6 - 0973 - 000		1	GEAR, 14T/26T 14T / 26T ギア	
71	FS6 - 0975 - 000		2	GEAR, 24T 24T ギア	
72	FS6 - 0976 - 000		1	GEAR, 20T 20T ギア	
73	FS6 - 0977 - 000		1	GEAR, 14T/26T 14T / 26T ギア	
74	FS6 - 0978 - 000		1	GEAR, 14T 14T ギア	
75	FS6 - 1025 - 000		2	BUSHING ブッシング	
76	FS6 - 2748 - 000		1	SPRING, COMPRESSION アッシュク バネ	
77	FS6 - 2749 - 000		2	SPRING, TENSION ヒツバリ バネ	
78	FS6 - 2981 - 000		1	SPRING, TENSION ヒツバリ バネ	
79	FS6 - 2991 - 000		3	SPRING, TENSION ヒツバリ バネ	
80	FS6 - 2994 - 000		1	SPRING, TORSION ネジリ バネ	
81	FS6 - 8399 - 000		1	LABEL, GREASE TYPE グリス指示ラベル	
82	FS7 - 0048 - 000		1	GEAR, 26T 26T ギア	
83	FS7 - 0050 - 000		1	GEAR, 23T/39T 23T / 39T ギア	

FIGURE & KEY NO.	PART NUMBER	RANK	QTY	DESCRIPTION	SERIAL NUMBER / REMARKS
600 - 84	FS7 - 2902 - 000		1	SPRING, TENSION ヒツバリ パネ	
85	VS1 - 5057 - 002		1	CONNECTOR, SNAP TIGHT チュウケイ コネクタ	J125
86	VS1 - 5057 - 003		1	CONNECTOR, SNAP TIGHT チュウケイ コネクタ	J129
87	VS1 - 5057 - 003		1	CONNECTOR, SNAP TIGHT チュウケイ コネクタ	J128
88	VS1 - 6318 - 005		1	CONNECTOR, SNAP TIGHT チュウケイ コネクタ	J5030
89	WT2 - 5565 - 000		2	CLAMP, CABLE ソクセン オサエ	
90	X71 - 9310 - 000		1	SEAL, OIL オイル シール	
91	XA9 - 0605 - 000		4	SCREW, M4X8 タイト ネジ	
92	XG9 - 0111 - 000		1	SEAL, OIL オイル シール	
93	XG9 - 0143 - 000		1	SEAL, OIL オイル シール	
94	XG9 - 0250 - 000		2	BEARING, BALL ボール ベアリング	
501	XA1 - 1160 - 207		4	SCREW, MACH., PAN HEAD, M1.6X2 ナベ ネジ	
502	XB1 - 2300 - 602		2	SCREW, MACH., TRUSS HEAD, M3X6 バインド ネジ	
503	XB1 - 2300 - 609		23	SCREW, MACH., TRUSS HEAD, M3X6 バインド ネジ	
504	XB1 - 2300 - 809		4	SCREW, MACH., TRUSS HEAD, M3X8 バインド ネジ	
505	XB1 - 2301 - 007		4	SCREW, MACH., TRUSS HEAD, M3X10 バインド ネジ	
506	XB1 - 2400 - 609		7	SCREW, MACH., TRUSS HEAD, M4X6 バインド ネジ	SEE NOTE 2
507	XB1 - 2400 - 609		36	SCREW, MACH., TRUSS HEAD, M4X6 バインド ネジ	
508	XB1 - 2401 - 609		2	SCREW, MACH., TRUSS HEAD, M4X16 バインド ネジ	
509	XB2 - 7300 - 607		1	SCREW, W/WASHER, M3X6 バネツキ バインド ネジ	
510	XB2 - 8300 - 609		1	SCREW, W/WASHER, M3X6 バネツキ バインド ネジ	
511	XB4 - 7300 - 509		1	SCREW, TAPPING, TRUSS HEAD, M3X5 バインド タッピン ネジ	
512	XB4 - 7303 - 009		2	SCREW, TAPPING, TRUSS HEAD, M3X30 バインド タッピン ネジ	
513	XB4 - 7303 - 009		2	SCREW, TAPPING, TRUSS HEAD, M3X30 バインド タッピン ネジ	
514	XB6 - 7400 - 609		1	SCREW, TP, M4X6 TP ネジ	
515	XD1 - 1106 - 235		2	SHIM ヒョウジュン ワッシャ	
516	XD2 - 1100 - 322		6	RING, E E リング	
517	XD2 - 1100 - 402		8	RING, E E リング	
518	XD2 - 1100 - 502		6	RING, E E リング	
519	XD2 - 1100 - 642		4	RING, E E リング	

FIGURE & KEY NO.	PART NUMBER	R A N K	Q' T Y	DESCRIPTION	SERIAL NUMBER / REMARKS
600 - 520	XD2 - 1100 - 802		2	RING,E E リング	
521	XD2 - 2100 - 802		1	RING,GRIP グリップ リング	
522	XD2 - 2300 - 602		3	RING,GRIP グリップ リング	

FIGURE 640 DEVELOPING ASSEMBLY
現像器

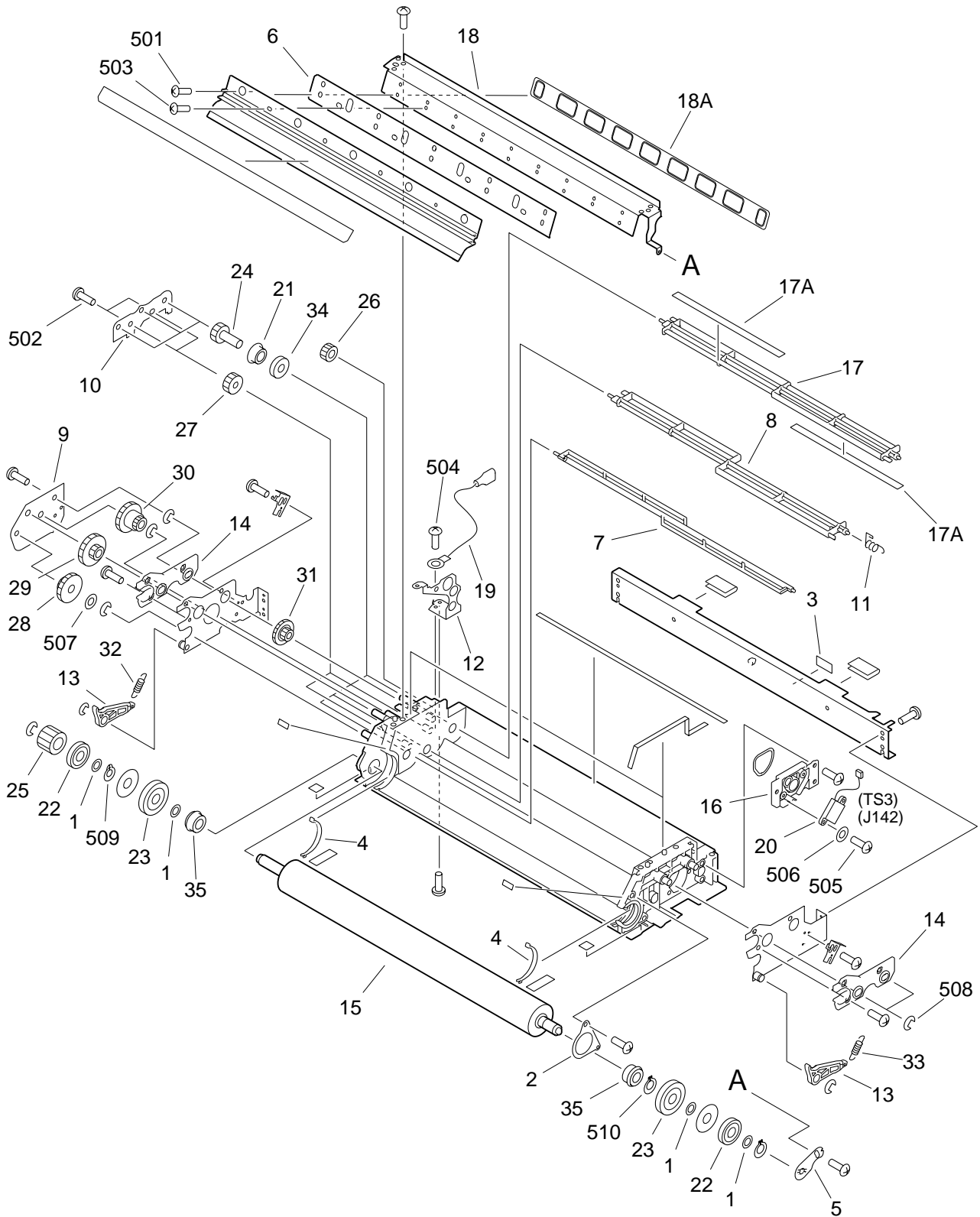

NOTE: This assembly includes the assembly shown in Figure 645.
注: このユニットはFigure645のユニットを含みます。

FIGURE & KEY NO.	PART NUMBER	RANK	QTY	DESCRIPTION	SERIAL NUMBER / REMARKS
640 -	FG6 - 8730 - 000		1	DEVELOPING ASSEMBLY 現像器	SEE NOTE
1	FA3 - 0515 - 000		4	WASHER ワッシャ	
2	FA6 - 7822 - 000		1	MOUNT, BUSHING 軸受押え	
3	FA9 - 3822 - 000		1	LABEL, DISCRIMINATE 識別ラベル	
4	FB4 - 0464 - 000		2	PLATE, MAGNETIC 磁性板	
5	FB4 - 1820 - 020		1	PLATE, MAGNET POSITIONING 極決め板	
6	FB4 - 1821 - 020		1	BLADE, MAGNET 磁性ブレード	
7	FB4 - 1824 - 000		1	ROD, STIRRING, 1 攪拌棒 (1)	
8	FB4 - 1825 - 000		1	ROD, STIRRING, 2 攪拌棒 (2)	
9	FB4 - 1828 - 000		1	RETAINER, REDUCTION GEAR 減速ギア押え	
10	FB4 - 1829 - 000		1	RETAINER, STIRRER DRIVE GEAR 攪拌ギア押え	
11	FB4 - 1831 - 000		1	SPRING, TORSION ネジリ バネ	
12	FB4 - 1837 - 000		1	TERMINAL, BIAS バイアス電極	
13	FB4 - 1862 - 000		2	ARM, PRESSURE 加圧アーム	
14	FB4 - 1866 - 000		2	MOUNT, PRESSURE SLIDE 加圧スライド台	
15	FB6 - 2370 - 000		1	CYLINDER, DEVELOPING 現像シリンダ	
16	FF5 - 7698 - 000		1	MOUNT, TONER SENSOR トナー センサ台	
17	FF5 - 7701 - 000		1	ROD, STIRRING, 3 攪拌棒 (3)	
17 A	FB4 - 1830 - 000		2	RUBBER, STIRRING 攪拌ゴム	
18	FF6 - 1041 - 000		1	MOUNT, BLADE SUPPORT ブレード台	
18 A	FB5 - 6853 - 000		1	SHEET シート	
19	FG6 - 1854 - 000		1	CABLE, HV, DEVELOPING UNIT 現像ユニット高圧束線	TS3,J142
20	FH7 - 7337 - 000		1	SENSOR, TONER トナー センサ	
21	FS2 - 1014 - 000		3	BUSHING ブッシング	
22	FS5 - 6574 - 000		2	ROLLER, PRESSURE 加圧コロ	
23	FS5 - 6579 - 000		2	COLLAR 突き当てコロ	
24	FS6 - 0857 - 000		3	GEAR, 20T 20T ギア	
25	FS6 - 0979 - 000		1	GEAR, 24T 24T ギア	
26	FS6 - 0980 - 000		1	GEAR, 19T 19T ギア	
27	FS6 - 0981 - 000		2	GEAR, 21T 21T ギア	

FIGURE & KEY NO.	PART NUMBER	RANK	QTY	DESCRIPTION	SERIAL NUMBER / REMARKS
640 - 28	FS6 - 0982 - 000		1	GEAR, 16T/31T 16T / 31T ギア	
29	FS6 - 0983 - 000		1	GEAR, 14T/34T 14T / 34T ギア	
30	FS6 - 0984 - 000		1	GEAR, 14T/32T 14T / 32T ギア	
31	FS6 - 0985 - 000		1	GEAR, 16T/34T 16T / 34T ギア	
32	FS6 - 2750 - 000		1	SPRING, TENSION ヒッバリ バネ	
33	FS6 - 2751 - 000		1	SPRING, TENSION ヒッバリ バネ	
34	X71 - 9310 - 000		3	SEAL, OIL オイル シール	
35	XG9 - 0120 - 000		2	BEARING, BALL ボール ベアリング	
501	XB1 - 2300 - 402		5	SCREW, MACH., TRUSS HEAD, M3X4 バインド ネジ	
502	XB1 - 2300 - 409		28	SCREW, MACH., TRUSS HEAD, M3X4 バインド ネジ	
503	XB1 - 2300 - 604		4	SCREW, MACH., TRUSS HEAD, M3X6 バインド ネジ	
504	XB2 - 7300 - 407		3	SCREW, W/WASHER, M3X4 バネツキ バインド ネジ	
505	XB4 - 7300 - 809		2	SCREW, TAPPING, TRUSS HEAD, M3X8 バインド タッピン ネジ	
506	XD1 - 1103 - 139		2	SHIM ヒョウジュン ワッシャ	
507	XD1 - 1106 - 222		1	SHIM ヒョウジュン ワッシャ	
508	XD2 - 1100 - 502		8	RING, E E リング	
509	XD2 - 2101 - 002		1	RING, GRIP グリップ リング	
510	XD2 - 3100 - 102		2	RING, C, EXTERNAL C リング (ジクヨウ)	

FIGURE 645 BUFFER ASSEMBLY

バッファ部

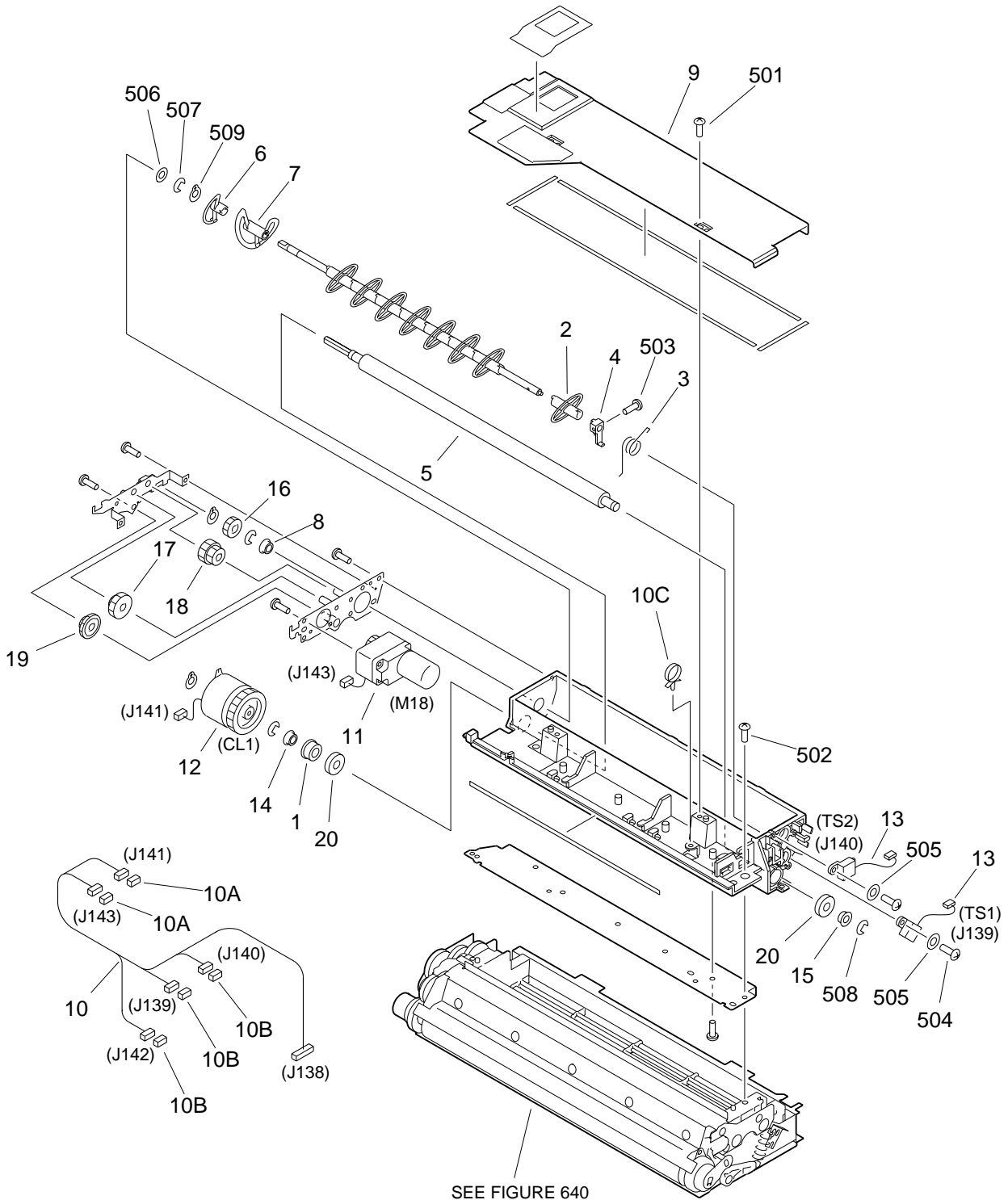

SEE FIGURE 640

NOTE1: This assembly is included in the assembly shown in Figure 640.
 NOTE2: This assembly does not include the part shown with key No. 502.
 注1: このユニットはFigure640のユニットに含まれます。
 注2: このユニットにKey No. 502の部品は含まれません。

FIGURE & KEY NO.	PART NUMBER	RANK	QTY	DESCRIPTION	SERIAL NUMBER / REMARKS
645 -	FG6 - 2011 - 000		1	BUFFER ASSEMBLY バッファ部	SEE NOTE 1
1	FA4 - 0207 - 000		1	HOLDER, OIL SEAL シール ホルダ	
2	FB4 - 1842 - 000		8	BLADE, STIRRING 攪拌羽根	
3	FB4 - 1849 - 000		1	SPRING, TORSION ネジリ バネ	
4	FB4 - 1850 - 000		1	MOUNT, SCRAPER スクレーパ台	
5	FB4 - 1856 - 000		1	ROLLER, MAGNET マグネット ローラ	
6	FB4 - 1857 - 000		1	BLADE, STIRRING 攪拌羽根	
7	FB4 - 1858 - 000		1	BLADE, STIRRING 攪拌羽根	
8	FF2 - 5730 - 000		1	BUSHING ブッシング	
9	FF5 - 7695 - 000		1	COVER, BUFFER バッファ カバー	
10	FG6 - 1891 - 000		1	CABLE, BUFFER UNIT バッファ ユニット束線	J138-143
10 A	VS1 - 5057 - 002		2	CONNECTOR, SNAP TIGHT チュウケイ コネクタ	J141,143
10 B	VS1 - 5057 - 003		3	CONNECTOR, SNAP TIGHT チュウケイ コネクタ	J139,140,142
10 C	WT2 - 5565 - 000		1	CLAMP, CABLE ソクセン オサエ	
11	FH6 - 1543 - 000		1	MOTOR, DC 16.8W DCモータ	M18 J143
12	FH7 - 5840 - 000		1	CLUTCH, ELECTROMAGNETIC 電磁クラッチ	CL1 J141
13	FH7 - 7337 - 000		2	SENSOR, TONER トナー センサ	TS1,2 J139,140
14	FS1 - 1202 - 000		1	BUSHING ブッシング	
15	FS1 - 1503 - 000		1	BUSHING ブッシング	
16	FS2 - 0875 - 000		1	GEAR, 16T 16T ギア	
17	FS6 - 0988 - 000		1	GEAR, 14T/27T 14T / 27T ギア	
18	FS6 - 0989 - 000		1	GEAR, 18T/19T 18T / 19T ギア	
19	FS6 - 0990 - 000		1	GEAR, 14T/27T 14T / 27T ギア	
20	X71 - 9310 - 000		2	SEAL, OIL オイル シール	
501	XB1 - 2300 - 409		13	SCREW,MACH.,TRUSS HEAD,M3X4 バインド ネジ	
502	XB1 - 2300 - 409		4	SCREW,MACH.,TRUSS HEAD,M3X4 バインド ネジ	SEE NOTE 2
503	XB1 - 2300 - 809		1	SCREW,MACH.,TRUSS HEAD,M3X8 バインド ネジ	
504	XB4 - 7300 - 809		9	SCREW,TAPPING,TRUSS HEAD,M3X8 バインド タッピン ネジ	
505	XD1 - 1103 - 139		4	SHIM ヒョウジュン ワッシャ	
506	XD1 - 1106 - 221		1	SHIM ヒョウジュン ワッシャ	

FIGURE & KEY NO.	PART NUMBER	R A N K	Q' T Y	DESCRIPTION	SERIAL NUMBER / REMARKS
645 - 507	XD2 - 1100 - 502		2	RING,E E リング	
508	XD2 - 1100 - 642		2	RING,E E リング	
509	XD2 - 2100 - 602		3	RING,GRIP グリップ リング	

FIGURE 720 SEPARATION CLAW DRIVE ASSEMBLY 分離爪駆動部

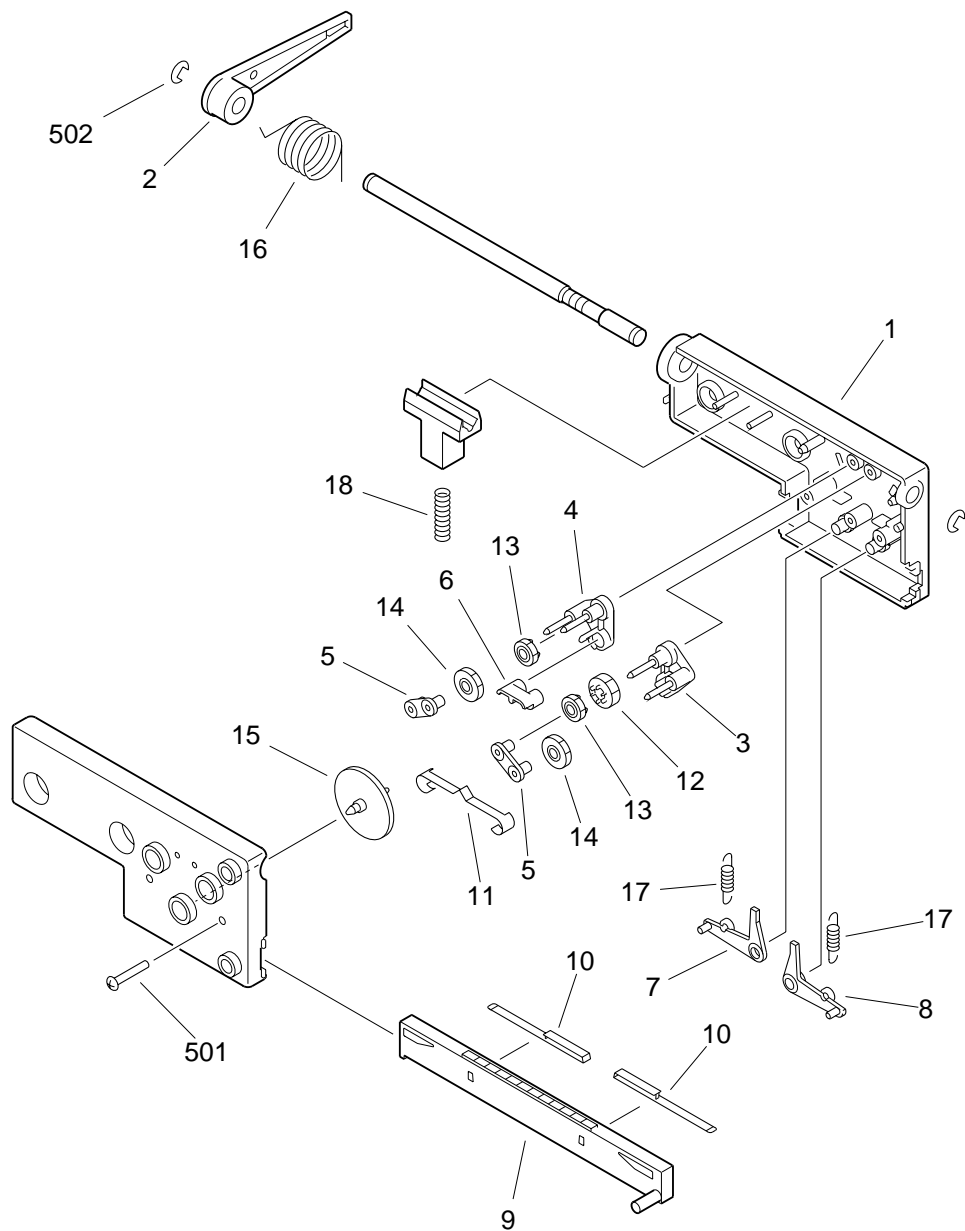

NOTE: This assembly is included in the assembly shown in Figure 600.
注：このユニットはFigure600のユニットに含まれます。

FIGURE & KEY NO.	PART NUMBER	R A N K	Q' T Y	DESCRIPTION	SERIAL NUMBER / REMARKS
720 -	FG1 - 3472 - 000		1	SEPARATION CLAW DRIVE ASSEMBLY 分離爪駆動部	SEE NOTE
1	FA3 - 2471 - 000		1	BASE ベ-ス	
2	FA3 - 2472 - 000		1	LEVER クドウレバ-	
3	FA3 - 2473 - 000		1	LINK, RIGHT ユウドウ リンク (ミギ)	
4	FA3 - 2474 - 000		1	LINK, LEFT ユウドウ リンク (ヒダリ)	
5	FA3 - 2475 - 000		2	BRACE ツナギ リンク	
6	FA3 - 2476 - 000		1	LINK クリック リンク	
7	FA3 - 2477 - 000		1	LEVER, RIGHT キリカエ レバ- (ミギ)	
8	FA3 - 2478 - 000		1	LEVER, LEFT キリカエ レバ- (ヒダリ)	
9	FA3 - 2479 - 000		1	RACK ラック	
10	FA3 - 2480 - 000		2	SPRING, LEAF イタ バネ	
11	FA3 - 2481 - 000		1	SPRING, LEAF クリック イタ バネ	
12	FS2 - 0088 - 000		1	GEAR, 20T 20T ギア	
13	FS2 - 0089 - 000		2	GEAR, 20T 20T ギア	
14	FS2 - 0090 - 000		2	GEAR, 25T 25T ギア	
15	FS2 - 0091 - 000		1	GEAR, 60T 60T ギア	
16	FS2 - 2001 - 000		1	SPRING, TORSION ネジリ バネ	
17	FS2 - 2002 - 000		2	SPRING, TENSION ヒツパリ バネ	
18	FS2 - 2058 - 000		1	SPRING, COMPRESSION アッシュク バネ	
501	XB4 - 7301 - 209		2	SCREW, TAPPING, TRUSS HEAD, M3X12 バインド タッピン ネジ	
502	XD2 - 1100 - 502		2	RING, E リング	

FIGURE 770 WASTE TONER ASSEMBLY 廃トナー部

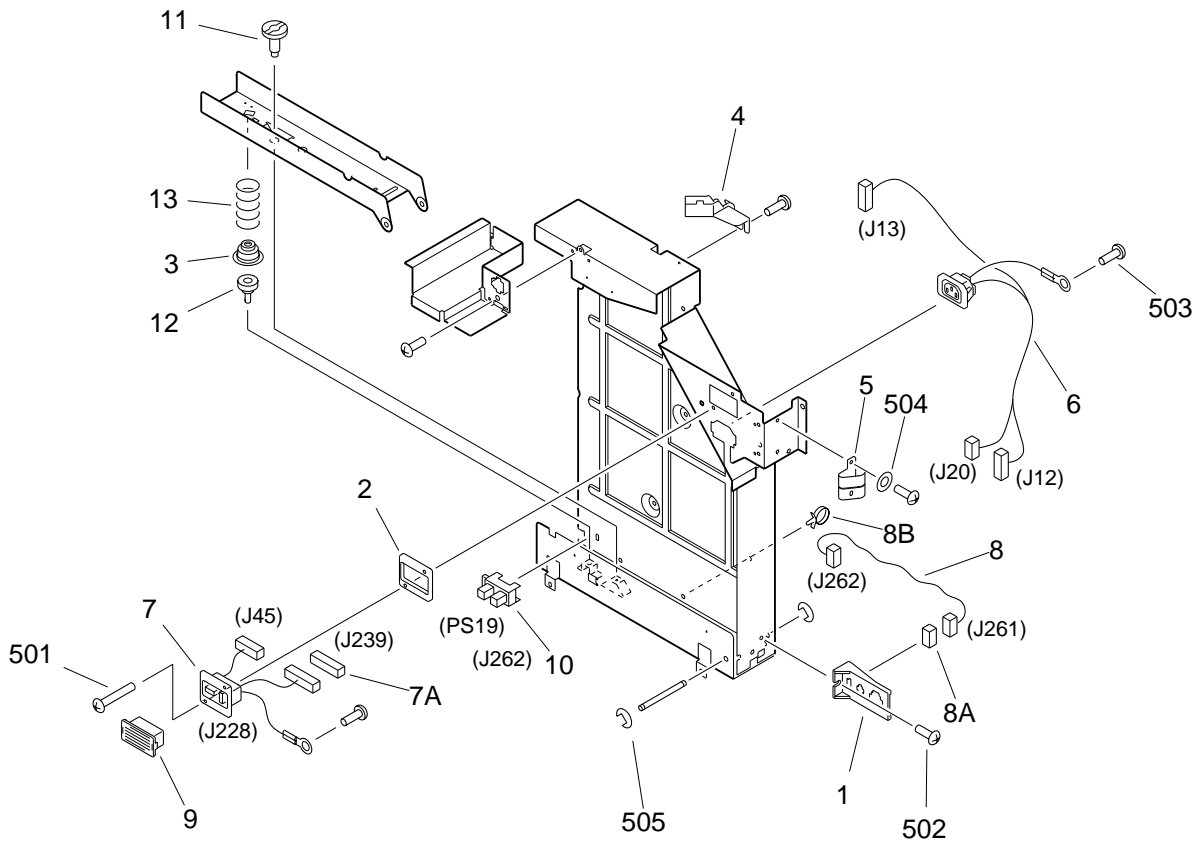

NOTE: This assembly does not include the part shown with key No. 9.
注：このユニットにKey No. 9の部品は含まれません。

FIGURE & KEY NO.	PART NUMBER	RANK	QTY	DESCRIPTION	SERIAL NUMBER / REMARKS
770 -	FG6 - 7747 - 000		1	WASTE TONER ASSEMBLY 廃トナー部	
1	FB4 - 1443 - 000		1	MOUNT, AC CONNECTOR ACコネクタ台	
2	FB4 - 1542 - 000		1	SPACER, LATTICE CABLE ラティス束線スペーサ	
3	FB4 - 9511 - 000		1	SUPPORT, SPRING バネ座	
4	FB4 - 9799 - 000		1	GUIDE, CABLE 束線ガイド	
5	FB6 - 0783 - 000		1	SPRING, LEAF, GROUNDING アース バネ	
6	FG6 - 1818 - 000		1	CABLE, MAIN SWITCH CONNECTING メイン スイッチ中継束線	J12,13,20
7	FG6 - 1819 - 000		1	CABLE, LATTICE, 3.5K DECK ラティス束線(3.5KPD)	J45,228,239
7 A	VS1 - 5057 - 007		1	CONNECTOR, SNAP TIGHT チュウケイ コネクタ	J239
8	FG6 - 1820 - 000		1	CABLE, WASTE TONER SENSOR 廃トナー検知束線	J261,262
8 A	VS1 - 5057 - 003		1	CONNECTOR, SNAP TIGHT チュウケイ コネクタ	J261
8 B	WT2 - 5565 - 000		4	CLAMP, CABLE ソクセン オサエ	
9	FH2 - 6552 - 000		1	COVER, CONNECTOR コネクタ カバー	SEE NOTE
10	FH7 - 7462 - 000		1	PHOTO-INTERRUPTER フォトインタラプタ	PS19 J262
11	FS2 - 9410 - 000		1	SCREW, STEPPED, M4X12.7 段ビス	
12	FS5 - 9398 - 000		1	SCREW, SIDE REGIST., M3X8 横レジ ビス	
13	FS6 - 2760 - 000		1	SPRING, COMPRESSION アッシュク バネ	
501	XB1 - 2301 - 407		2	SCREW,MACH.,TRUSS HEAD,M3X14 バインド ネジ	
502	XB1 - 2400 - 609		5	SCREW,MACH.,TRUSS HEAD,M4X6 バインド ネジ	
503	XB2 - 7400 - 607		2	SCREW,W/WASHER,M4X6 バネツキ バインド ネジ	
504	XD1 - 1104 - 138		2	SHIM ヒョウジュン ワッシャ	
505	XD2 - 1100 - 502		2	RING,E E リング	

FIGURE 775 WASTE TONER PIPE ASSEMBLY 廃トナーパイプ部

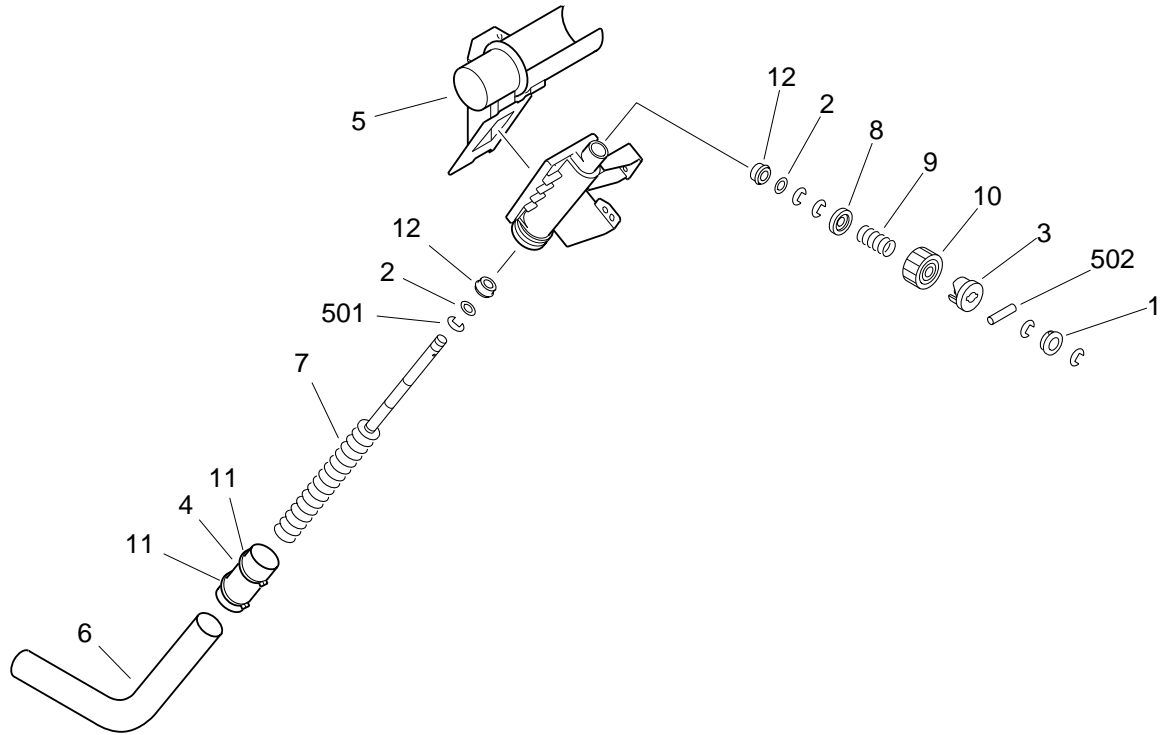

FIGURE & KEY NO.	PART NUMBER	RANK	QTY	DESCRIPTION	SERIAL NUMBER / REMARKS
775 -	FG6 - 2020 - 020		1	WASTE TONER PIPE ASSEMBLY 廃トナー パイプ部	
1	FA9 - 2112 - 000		1	BUSHING ブッシング	
2	FB2 - 6285 - 000		2	SHIM ワッシャ	
3	FB2 - 7981 - 000		1	CAM カム	
4	FB2 - 8402 - 000		1	TUBE チューブ	
5	FB4 - 1792 - 000		1	CAP, WASTE TONER, 1 廃トナー キャップ (1)	
6	FB4 - 1794 - 000		1	PIPE, WASTE TONER 廃トナー パイプ	
7	FB4 - 1795 - 000		1	SHAFT, WASTE TONER 廃トナー軸	
8	FB4 - 1797 - 000		1	SUPPORT, SPRING バネ受け	
9	FS6 - 2756 - 000		1	SPRING, COMPRESSION アッシュク バネ	
10	FS7 - 0027 - 000		1	GEAR, 26T 26T ギア	
11	X62 - 7921 - 000		2	CLAMP, CABLE 束線バンド	
12	XG9 - 0211 - 000		2	BALL BEARING, MF128ZZ1MC3D4M ボール ベアリング	
501	XD2 - 1100 - 642		4	RING, E E リング	
502	XD3 - 2200 - 182		1	PIN, DOWEL ヘイコウ ピン	

FIGURE 810 FIXING ASSEMBLY(2/2) 定着器(2/2)

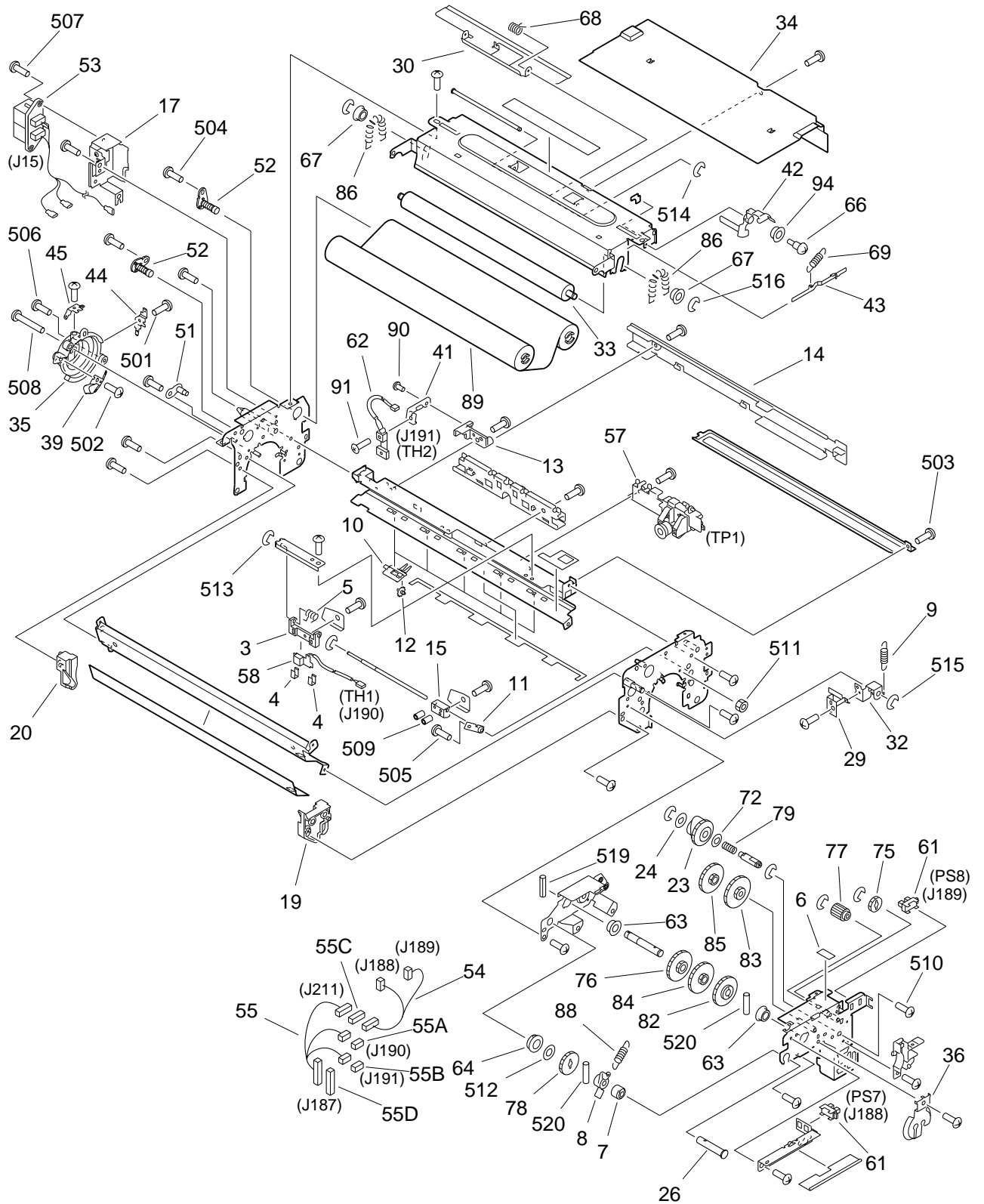

FIGURE & KEY NO.	PART NUMBER	RANK	QTY	DESCRIPTION	SERIAL NUMBER / REMARKS
810 -	FG6 - 8042 - 000		1	FIXING ASSEMBLY 定着器	200V SEE NOTE
	FG6 - 8735 - 000		1	FIXING ASSEMBLY 定着器	208V SEE NOTE
	FG6 - 8043 - 000		1	FIXING ASSEMBLY 定着器	220/240V SEE NOTE
	1 FA2 - 9037 - 000		2	CLAW, SEPARATION, LOWER 分離爪(下)	
	2 FA3 - 8894 - 000		2	RING, RETAINING トメワ	
3	FA5 - 4400 - 000		1	MOUNT, THERMISTOR サ-ミスタ トリツケ ダイ	
4	FA5 - 4403 - 000		2	SPRING, LEAF サ-ミスタ オサエ バネ	
5	FA6 - 8003 - 000		1	SPRING, TORSION ネジリ バネ	
6	FA9 - 3822 - 000		1	LABEL, DISCRIMINATE 識別ラベル	
7	FB1 - 6833 - 000		1	BUSHING ブッシング	
8	FB2 - 7228 - 000		1	ARM, ONE-WAY ワンウェイ ア-ム	
9	FB2 - 7238 - 000		1	SPRING, TENSION ヒツパリ バネ	
10	FB2 - 7240 - 000		5	MOUNT, ROWEL ハクシャ ダイ	
11	FB2 - 7261 - 000		1	BUSHING レシプロ ジク ウケ	
12	FB2 - 7264 - 000		5	ROWEL 拍車	
13	FB3 - 8409 - 000		1	HOLDER, THERMISTOR, 2 サ-ミスタ ホルダ(2)	
14	FB3 - 8412 - 000		1	COVER, CROSSMEMBER ステイ カバー	
15	FB3 - 9372 - 000		1	BLOCK, MOUNTING 束線固定ブロック	
16	FB4 - 2159 - 000		1	HOLDER, BUSHING 軸受ホルダ	
17	FB4 - 2183 - 000		1	MOUNT, AC CONNECTOR, 1 ACコネクタ台(1)	
18	FB4 - 2191 - 000		1	LEVER, PAPER JAM SENSOR 滞留センサ レバー	
19	FB4 - 2195 - 020		1	BLOCK, CLAW STOP, FRONT 爪ストップバ(前)	
20	FB4 - 2196 - 020		1	BLOCK, CLAW STOP, REAR 爪ストップバ(後)	
21	FB4 - 2214 - 000		1	ELIMINATOR, STATIC CHARGE 除電針	
22	FB4 - 2239 - 000		1	RING, BIAS バイアス リング	
23	FB4 - 9360 - 000		1	GEAR CAM, 50T 50T ギア カム	
24	FB4 - 9361 - 000		1	PLATE, FRICTION 摩擦板	
25	FB4 - 9524 - 000		1	COLLAR カラー	
26	FB5 - 6825 - 000		1	SHAFT, ONE-WAY ワンウェイ軸	
27	FB5 - 6833 - 000		1	ROLLER, INTERNAL DELIVERY 内排紙ローラ	

FIGURE & KEY NO.	PART NUMBER	RANK	Q'TY	DESCRIPTION	SERIAL NUMBER / REMARKS
810 - 28	FB5 - 6930 - 000		1	ROLLER, FIXING 定着ローラ	
29	FB5 - 6931 - 000		1	PLATE, LIMIT, ARM アーム規制板	
30	FB5 - 6932 - 000		1	SUPPORT, WEB RETAINER ウェブ押え板	
31	FB5 - 6934 - 000		2	BUSHING ブッシング	
32	FB5 - 6935 - 000		1	PLATE, LIMIT, ARM, 2 アーム規制板 (2)	
33	FB5 - 6936 - 000		1	ROLLER, CLEANING ウェブ ローラ	
34	FB5 - 6941 - 000		1	COVER, FIXING, UPPER 定着カバー (上)	
35	FB5 - 6944 - 000		1	HOLDER, HEATER ヒータ ホルダ	
36	FB5 - 6945 - 000		1	SUPPORT, HEATER ヒータ支持板	
37	FB5 - 6946 - 000		1	GUIDE, INLET 入口ガイド	
38	FB5 - 6948 - 000		2	PLATE, HEIGHT ADJUSTING 高さ調整板	
39	FB5 - 6951 - 000		1	TERMINAL, BIAS バイアス接点	
40	FB5 - 6952 - 000		1	ROLLER, PRESSURE 加圧ローラ	
41	FB5 - 6957 - 000		1	HOLDER, THERMISTOR, 1 サーミスタ ホルダ (1)	
42	FB5 - 6973 - 000		1	LEVER, PAPER SENSOR ウェブ残量検知レバー	
43	FB5 - 7077 - 000		1	PLATE, LIMIT, LEVER レバー規制板	
44	FB5 - 7558 - 000		1	TERMINAL, HEATER, LARGE ヒータ端子 (大)	
45	FB5 - 7559 - 000		1	TERMINAL, HEATER, SMALL ヒータ端子 (小)	
46	FB5 - 7560 - 000		1	COLLAR, FIXING ROLLER 定着ローラ カラー	
47	FB5 - 7562 - 000		2	SUPPORT, BEARING ベアリング押さえ	
48	FB5 - 7660 - 000		1	GUIDE, DELIVERY, LOWER 排紙ガイド (下)	
49	FF5 - 7860 - 000		1	PIN, POSITIONING 位置決めピン	
50	FF6 - 1082 - 000		2	SUPPORT, FIXING POSITION 定着位置決め支板	
51	FF6 - 1087 - 000		1	PLATE, PIN フロート ピン	
52	FF6 - 1851 - 000		2	HOLDER, WEB ウェブ支軸	
53	FG6 - 1875 - 000		1	CABLE, AC, FIXING/FEEDER 定着 / 搬送AC束線	J15
54	FG6 - 1880 - 000		1	CABLE, CLEANING BELT SENSOR ウェブ センサ束線	J188,189,211
55	FG6 - 1881 - 000		1	CABLE, DC, FIXING, UPPER 定着DC上束線	J187,190,191,211
55 A	VS1 - 5057 - 002		1	CONNECTOR, SNAP TIGHT チュウケイ コネクタ	J190
55 B	VS1 - 5057 - 003		1	CONNECTOR, SNAP TIGHT チュウケイ コネクタ	J191

FIGURE & KEY NO.	PART NUMBER	RANK	QTY	DESCRIPTION	SERIAL NUMBER / REMARKS
810 - 55C	VS1 - 5057 - 006		1	CONNECTOR, SNAP TIGHT チュウケイ コネクタ	J211
55D	VS1 - 6318 - 010		1	CONNECTOR, SNAP TIGHT チュウケイ コネクタ	J187
56	FG6 - 7200 - 000		1	CABLE, DC, FIXING 定着DC束線	J192,194
56A	VS1 - 6318 - 006		1	CONNECTOR, SNAP TIGHT チュウケイ コネクタ	J192
57	FG6 - 7745 - 000		1	THERMOSWITCH HOLDER UNIT サーモ スイッチ ホルダ ユニット	TP1
58	FG6 - 7748 - 000		1	THERMISTOR UNIT サーミスタ ユニット	TH1 J190
59	FH7 - 4719 - 000		1	HEATER, HALOGEN ハロゲン ヒータ	200/208V H1
	FH7 - 4720 - 000		1	HEATER, HALOGEN ハロゲン ヒータ	220/240V H1
60	FH7 - 4723 - 000		1	HEATER, HALOGEN ハロゲン ヒータ	200/208V H2
	FH7 - 4724 - 000		1	HEATER, HALOGEN ハロゲン ヒータ	220/240V H2
61	FH7 - 7462 - 000		3	PHOTO-INTERRUPTER フォトインタラプタ	PS6,7,8 J194,188,189
62	FH7 - 7464 - 000		1	SUB THERMISTOR ASSEMBLY サブ サーミスタ部	TH2 J191
63	FS1 - 1449 - 000		2	BUSHING ブッシング	
64	FS1 - 1569 - 000		1	BUSHING ブッシング	
65	FS1 - 2834 - 000		2	SPRING, TENSION ヒツバリ バネ	
66	FS1 - 9051 - 000		1	SCREW, STEPPED, M3 段ビス	
67	FS2 - 1256 - 000		2	BUSHING ブッシング	
68	FS3 - 2053 - 000		1	SPRING, TORSION ネジリ バネ	
69	FS5 - 2940 - 000		1	SPRING, TENSION ヒツバリ バネ	
70	FS5 - 2950 - 000		1	SPRING, TORSION ネジリ バネ	
71	FS5 - 6487 - 000		2	SHIM ワッシャ	
72	FS5 - 6583 - 000		2	SPACER スペーサ	
73	FS5 - 9619 - 000		4	SCREW, STEPPED, M3 段ビス	
74	FS5 - 9752 - 000		2	SCREW, M5 加圧ビス	
75	FS6 - 0103 - 000		1	GEAR, 28T 28T ギア	
76	FS6 - 0105 - 000		1	GEAR, 22T/60T 22T / 60T ギア	
77	FS6 - 0106 - 000		1	GEAR, 23T 23T ギア	
78	FS6 - 0134 - 000		1	GEAR, 44T 44T ギア	
79	FS6 - 2990 - 000		1	SPRING, COMPRESSION アッシュク バネ	
80	FS7 - 0007 - 000		1	GEAR, 52T 52T ギア	

FIGURE & KEY NO.	PART NUMBER	R A N K	Q' T Y	DESCRIPTION	SERIAL NUMBER / REMARKS
810 - 81	FS7 - 0008 - 000		1	GEAR, 23T 23T ギア	
82	FS7 - 0891 - 000		1	GEAR, 60T 60T ギア	
83	FS7 - 0893 - 000		1	GEAR, 22T/63T 22T / 63T ギア	
84	FS7 - 0894 - 000		1	GEAR, 19T/63T 19T / 63T ギア	
85	FS7 - 0895 - 000		1	GEAR, 19T/60T 19T / 60T ギア	
86	FS7 - 2523 - 000		2	SPRING, TENSION ヒツパリ バネ	
87	FS7 - 2524 - 000		2	SPRING, COMPRESSION アッシュク バネ	
88	FS7 - 2530 - 000		1	SPRING, TENSION ヒツパリ バネ	
89	FY1 - 1157 - 000		1	ROLLER, CLEANING BELT ウェブ ローラ	
90	XA9 - 0807 - 000		1	SCREW, TP, M3X6 TP ネジ	
91	XA9 - 0925 - 000		1	SCREW, MACH., TRUSS HEAD, M3X10 バインド ネジ	
92	XG9 - 0211 - 000		1	BALL BEARING, MF128ZZ1MC3D4M ボール ベアリング	
93	XG9 - 0366 - 000		1	BEARING, BALL ボール ベアリング	
94	XG9 - 0406 - 000		1	BEARING, BALL ボール ベアリング	
95	XG9 - 0421 - 000		2	BEARING, BALL ボール ベアリング	
96	XG9 - 0447 - 000		2	BEARING, BALL ボール ベアリング	
501	XB1 - 2300 - 409		4	SCREW, MACH., TRUSS HEAD, M3X4 バインド ネジ	
502	XB1 - 2300 - 609		3	SCREW, MACH., TRUSS HEAD, M3X6 バインド ネジ	
503	XB1 - 2400 - 409		7	SCREW, MACH., TRUSS HEAD, M4X4 バインド ネジ	
504	XB1 - 2400 - 609		34	SCREW, MACH., TRUSS HEAD, M4X6 バインド ネジ	
505	XB1 - 2400 - 809		3	SCREW, MACH., TRUSS HEAD, M4X8 バインド ネジ	
506	XB1 - 2401 - 009		2	SCREW, MACH., TRUSS HEAD, M4X10 バインド ネジ	
507	XB2 - 8401 - 009		5	SCREW, W/WASHER, M4X10 パネツキ バインド ネジ	
508	XB2 - 8401 - 209		2	SCREW, W/WASHER, M4X12 パネツキ バインド ネジ	
509	XB6 - 2300 - 408		2	SETSCREW, M3X4 ロツカク アナツキ トメネジ	
510	XB6 - 7300 - 609		1	SCREW, TP, M3X6 TP ネジ	
511	XB7 - 2200 - 409		1	NUT, HEX, M4 ロツカク ナット	
512	XD1 - 1106 - 222		1	SHIM ヒョウジュン ワッシャ	
513	XD2 - 1100 - 242		1	RING, E E リング	
514	XD2 - 1100 - 322		5	RING, E E リング	

FIGURE & KEY NO.	PART NUMBER	RANK	QTY	DESCRIPTION	SERIAL NUMBER / REMARKS
810 - 515	XD2 - 1100 - 502		10	RING, E E リング	
516	XD2 - 1100 - 642		6	RING, E E リング	
517	XD2 - 1100 - 802		1	RING, E E リング	
518	XD2 - 1200 - 902		2	RING, E E リング	
519	XD3 - 1300 - 142		1	PIN, SPRING スプリング ピン	
520	XD3 - 2200 - 122		2	PIN, DOWEL ヘイコウ ピン	

FIGURE 900 CONTROLLER BOX ASSEMBLY コントローラ ボックス部

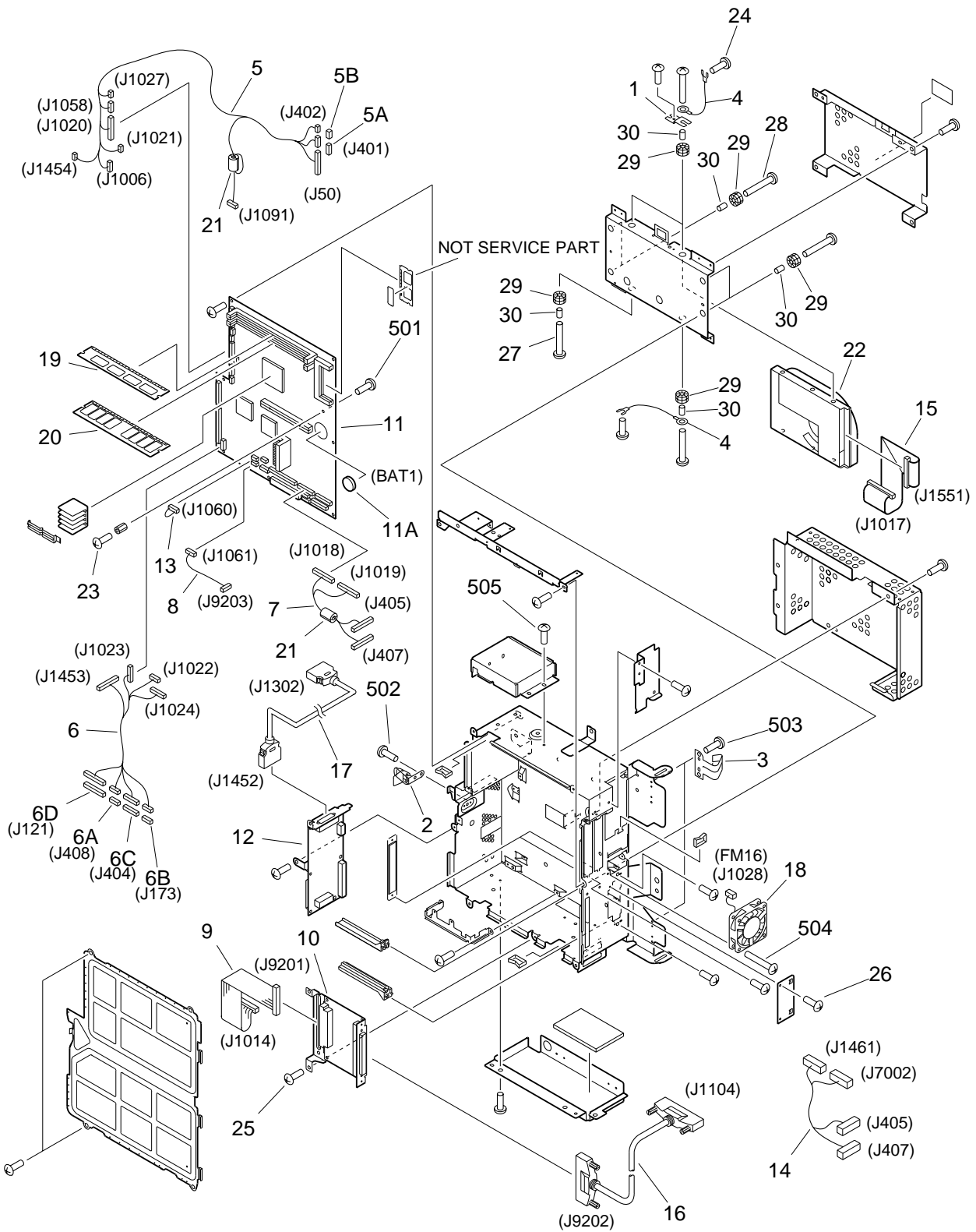

NOTE: This assembly does not include the part shown with key No. 16.

注: このユニットにKey No. 16の部品は含まれません。

FIGURE & KEY NO.	PART NUMBER	RANK	QTY	DESCRIPTION	SERIAL NUMBER / REMARKS
900 -	NPN		RF	CONTROLLER BOX ASSEMBLY コントローラ ボックス部	
1	FB5 - 4010 - 000		1	GROUNDING PLATE, HARD DISK ハード ディスク アース板	
2	FB5 - 8482 - 000		1	HOOK, COVER 蓋止め	
3	FB6 - 0782 - 000		2	SPRING, LEAF アース パネ	
4	FG6 - 6853 - 000		2	CABLE, GROUNDING アース線	
5	FG6 - 7216 - 000		1	CABLE, CONTROLLER コントローラ中継束線	J50,401,402,1006 J1020,1021,1027,1058 J1091,1454
5 A	VS1 - 6318 - 004		1	CONNECTOR, SNAP TIGHT チュウケイ コネクタ	J401
5 B	VS1 - 6318 - 009		1	CONNECTOR, SNAP TIGHT チュウケイ コネクタ	J402
6	FG6 - 7217 - 000		1	CABLE, PIXEL/LINE CHANGE 画素 / ライン変換束線	J121,173,404,408 J1022-1024,1453
6 A	VS1 - 6318 - 005		1	CONNECTOR, SNAP TIGHT チュウケイ コネクタ	J408
6 B	VS1 - 6318 - 007		1	CONNECTOR, SNAP TIGHT チュウケイ コネクタ	J173
6 C	VS1 - 6318 - 011		1	CONNECTOR, SNAP TIGHT チュウケイ コネクタ	J404
6 D	VS1 - 6319 - 028		1	CONNECTOR, SNAP TIGHT チュウケイ コネクタ	J121
7	FG6 - 7218 - 000		1	CABLE, CONTROL PANEL 操作部束線	J405,407,1018,1019
8	FG6 - 7222 - 000		1	CABLE, DDI-S POWER SUPPLY DDI - S電源束線	J1061,9203
9	FG6 - 7258 - 000		1	CABLE, FLAT フラット ケーブル	J1014,9201
10	FG6 - 7266 - 000		1	LVDS PCB ASSEMBLY 差動ボード回路基板	
11	FG6 - 7278 - 000		1	MAIN CONTROLLER PCB ASSY メイン コントローラ回路基板	
11 A	WK1 - 5019 - 000		1	BATTERY,LITHIUM,CR2477-HE6H 3V バッテリー	BAT1
12	FG6 - 7281 - 000		1	PIXEL/LINE CHANGE PCB ASSEMBLY 画素 / ライン変換回路基板	
13	FG6 - 7284 - 000		1	CABLE, CC-IV CC - IV束線	J1060
14	FG6 - 8614 - 000		1	CABLE, CONTROL PANEL CONNECT 操作部中継束線	J405,407,1461,7002
15	FG6 - 8625 - 000		1	CABLE, HARD DISK ハード ディスク中継束線	J1017,1551
16	FH2 - 6756 - 000		1	CABLE, DDI-S INTERFACE DDI - S I/Fケーブル	SEE NOTE J1104,9202
17	FH2 - 6900 - 000		1	CABLE, SHIELD シールド ケーブル	J1302,1452
18	FH6 - 1878 - 000		1	FAN ファン モータ	FM16 J1028
19	WA7 - 1497 - 000		1	DIMM, MT4LSDT864AG-133 DIMM	
20	WA7 - 1498 - 000		1	DIMM, MT8LSDT1664AG-133 DIMM	
21	WE8 - 5851 - 000		2	CORE, FERRITE フェライト コア	

FIGURE & KEY NO.	PART NUMBER	RANK	QTY	DESCRIPTION	SERIAL NUMBER / REMARKS
900 - 22	WM2 - 5152 - 000		1	HARD DISK DRIVE ハード ディスク	
23	XA9 - 0465 - 000		1	SCREW, W/WASHER, M3X4 パネツキ ナベ ネジ	
24	XA9 - 0828 - 000		3	SCREW, W/STAR WASHER, M3X4 キクザツキ バインド ネジ	
25	XA9 - 0836 - 000		22	SCREW, TP, M3X6 TP ネジ	
26	XA9 - 0836 - 000		2	SCREW, TP, M3X6 TP ネジ	
27	XA9 - 1207 - 000		4	SCREW, M4X12 ユニファイ セムス ビス	
28	XA9 - 1208 - 000		4	SCREW, M3X12 セムス ビス	
29	XH9 - 0110 - 000		8	RUBBER, CUSHION クッション ゴム	
30	XZ9 - 0503 - 000		8	SPACER スペーサ	
501	XB1 - 2300 - 607		1	SCREW, MACH., TRUSS HEAD, M3X6 バインド ネジ	
502	XB1 - 2300 - 607		2	SCREW, MACH., TRUSS HEAD, M3X6 バインド ネジ	
503	XB1 - 2400 - 607		16	SCREW, MACH., TRUSS HEAD, M4X6 バインド ネジ	
504	XB1 - 2402 - 009		2	SCREW, MACH., TRUSS HEAD, M4X20 バインド ネジ	
505	XB6 - 7300 - 405		4	SCREW, TP, M3X4 TPビス (M3x4)	

FIGURE 910 DC POWER SUPPLY PCB ASSEMBLY

DC電源回路基板

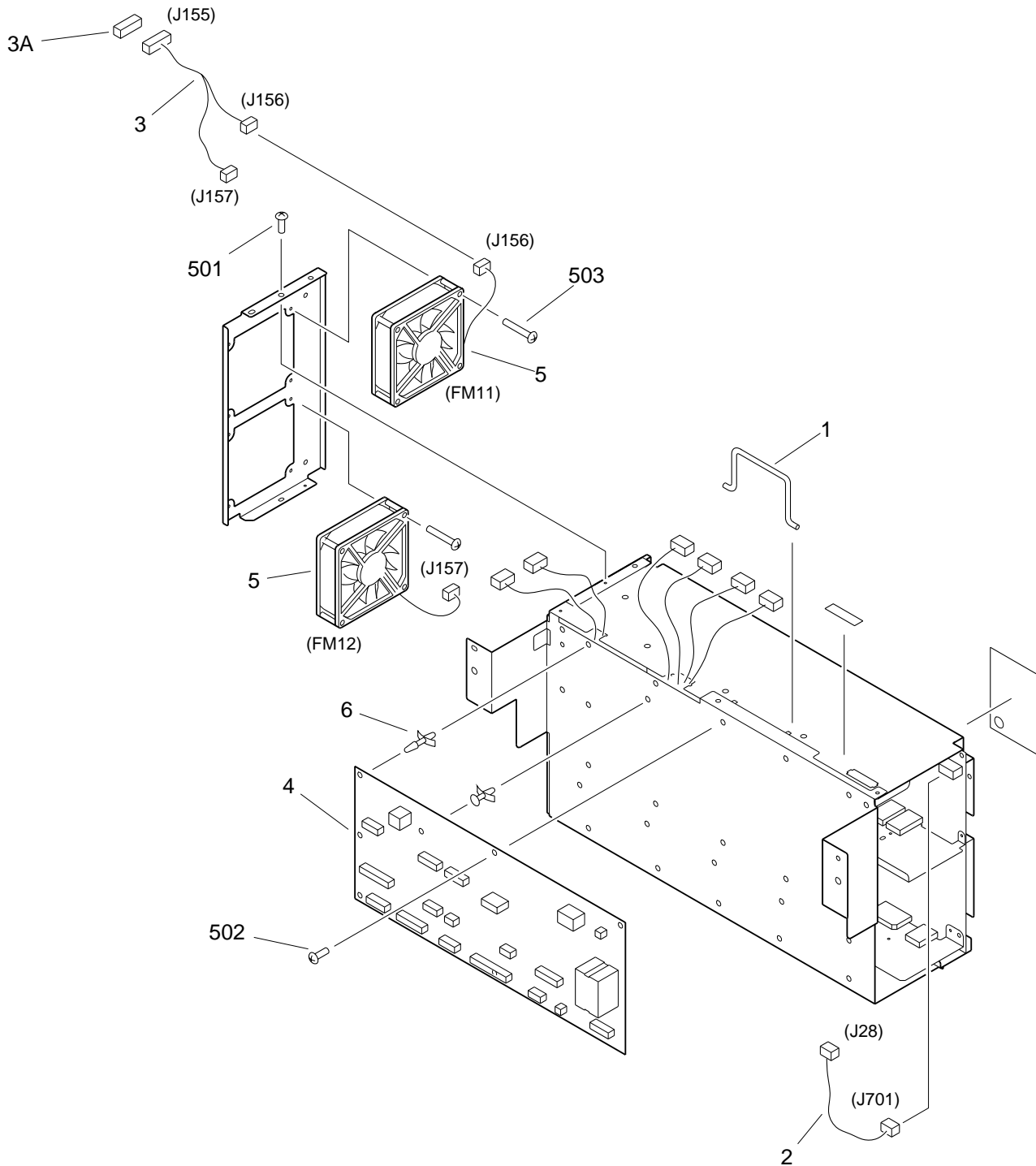

NOTE: This assembly does not include the parts shown with key No. 4 and 501.
 注: このユニットにKey No. 4、501の部品は含まれません。

FIGURE & KEY NO.	PART NUMBER	RANK	QTY	DESCRIPTION	SERIAL NUMBER / REMARKS
910 -	FG6 - 8597 - 000		1	DC POWER SUPPLY PCB ASSEMBLY DC電源回路基板	200V
	FG6 - 8598 - 000		1	DC POWER SUPPLY PCB ASSEMBLY DC電源回路基板	208V
	FG6 - 7238 - 000		1	DC POWER SUPPLY PCB ASSEMBLY DC電源回路基板	220/240V
	1 FB4 - 1612 - 000		1	HANDLE 把手	
	2 FG6 - 1882 - 000		1	CABLE, POWER SUPPLY INTERNAL 電源内部束線	J28,701
3	FG6 - 1887 - 000		1	CABLE, POWER SUPPLY FAN 電源ファン束線	J155-157
3 A	VS1 - 6318 - 006		1	CONNECTOR, SNAP TIGHT チュウケイ コネクタ	J155
4	FG6 - 7239 - 000		1	RELAY PCB ASSEMBLY リレー回路基板	SEE NOTE
5	FH6 - 1546 - 000		2	FAN, COOLING 冷却ファン	FM11,12 J156,157
6	VT2 - 0001 - 003		5	SUPPORT, PCB ロッキング サポート	
501	XB1 - 2300 - 607		1	SCREW,MACH.,TRUSS HEAD,M3X6 バインド ネジ	SEE NOTE
502	XB1 - 2300 - 607		1	SCREW,MACH.,TRUSS HEAD,M3X6 バインド ネジ	
503	XB1 - 2403 - 009		4	SCREW,MACH.,TRUSS HEAD,M4X30 バインド ネジ	
CT111	FH3 - 0666 - 000		1	TRANSFORMER トランス	208/220/240V
	FH3 - 0666 - 000		1	TRANSFORMER トランス	
CT301	FH3 - 0665 - 000		1	TRANSFORMER トランス	
FU101	VD7 - 0646 - 301		1	FUSE ヒューズ	
L 4	FH3 - 7195 - 000		1	CHOKE COIL, SN14-8000 チョーク コイル	208/220/240V
L251	FH3 - 0889 - 000		1	COIL, CHOKE チョーク コイル	
L351	FH3 - 0890 - 000		1	COIL, CHOKE チョーク コイル	
L501	FH3 - 0688 - 000		1	COIL, CHOKE チョーク コイル	
Q901	FH4 - 6040 - 000		2	IC, H8D2885, HYBRID ハイブリッドIC	
T301	FH3 - 0744 - 000		1	TRANSFORMER トランス	
T901	FH3 - 0888 - 000		1	TRANSFORMER トランス	
T931	FH3 - 0859 - 000		1	TRANSFORMER トランス	

FIGURE 920 CONTROL PANEL CPU PCB ASSEMBLY 操作部CPU回路基板

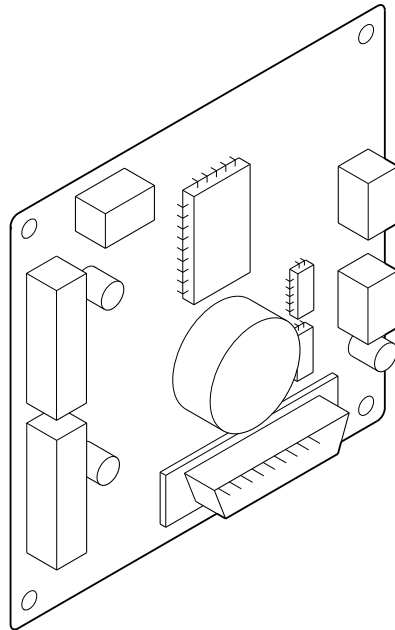

NOTE: This assembly is included in the assembly shown in Figure 130.
注：このユニットはFigure130のユニットに含まれます。

FIGURE & KEY NO.	PART NUMBER	RANK	QTY	DESCRIPTION	SERIAL NUMBER / REMARKS
920 -	FG3 - 2142 - 000		1	CONTROL PANEL CPU PCB ASSEMBLY 操作部CPU回路基板	SEE NOTE
Q6 8 2 2	FH4 - 1380 - 000		1	IC, N010-0559-V123, MPU マイクロ コンピュータ	

FIGURE 925 CONTROL PANEL INVERTER PCB ASSEMBLY

操作部インバータ回路基板

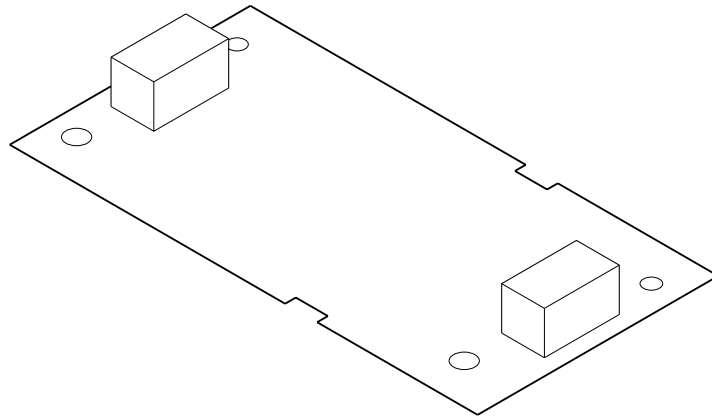

NOTE: This assembly is included in the assembly shown in Figure 130.
 注：このユニットはFigure130のユニットに含まれます。

FIGURE & KEY NO.	PART NUMBER	RANK	QTY	DESCRIPTION	SERIAL NUMBER / REMARKS
925 -	FG6 - 7738 - 000		1	C. PANEL INVERTER PCB ASSEMBLY 操作部インバータ回路基板	SEE NOTE
FU1	VD7 - 1622 - 001		1	FUSE, 2A, 60V ヒューズ	
T1	FH3 - 0961 - 000		1	TRANSFORMER, INVERTER インバータ トランス	

FIGURE 926 CONTROL PANEL PCB ASSEMBLY

操作部回路基板

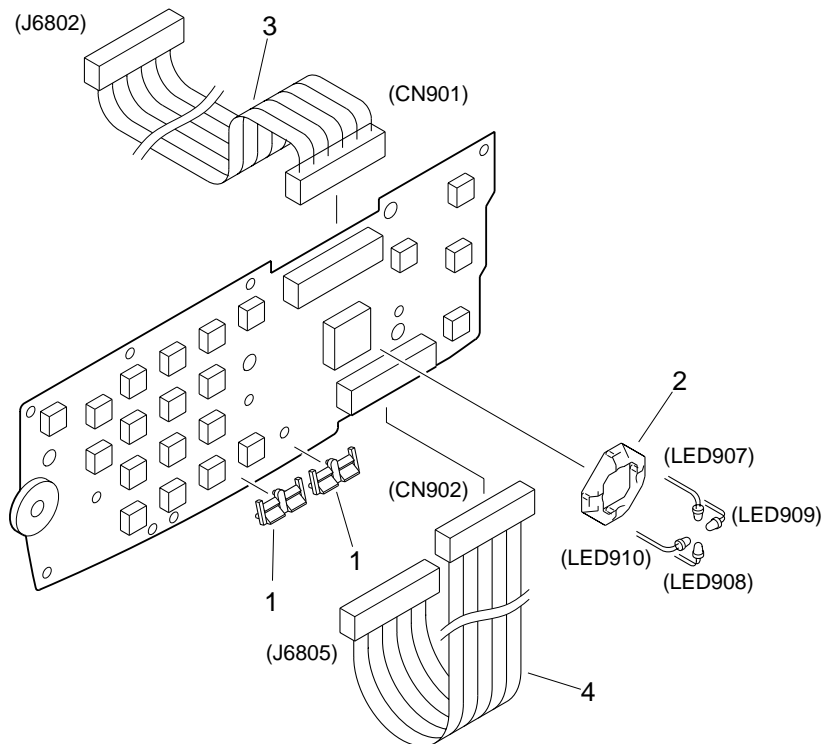

FIGURE & KEY NO.	PART NUMBER	RANK	QTY	DESCRIPTION	SERIAL NUMBER / REMARKS
926 -	FG3 - 2143 - 000		1	CONTROL PANEL PCB ASSEMBLY 操作部回路基板	
1	FB5 - 2174 - 000		2	HOLDER, LED, 2 LEDホルダ (2)	
2	FB5 - 2195 - 000		1	HOLDER, LED LEDホルダ	
3	FG3 - 2144 - 000		1	CABLE, KEY KEY束線	J6802,CN901
4	FG3 - 2145 - 000		1	CABLE, LED LED束線	J6805,CN902
LED907	FH6 - 0768 - 000		1	LED UNIT LEDユニット	
LED908	FH6 - 0768 - 000		1	LED UNIT LEDユニット	
LED909	FH6 - 0767 - 000		1	LED UNIT LEDユニット	
LED910	FH6 - 0767 - 000		1	LED UNIT LEDユニット	
VR901	FH6 - 0786 - 000		1	RESISTOR, VARIABLE 操作部コントラストVR (MB)	

FIGURE 930 DC CONTROLLER PCB ASSEMBLY

DCコントローラ回路基板

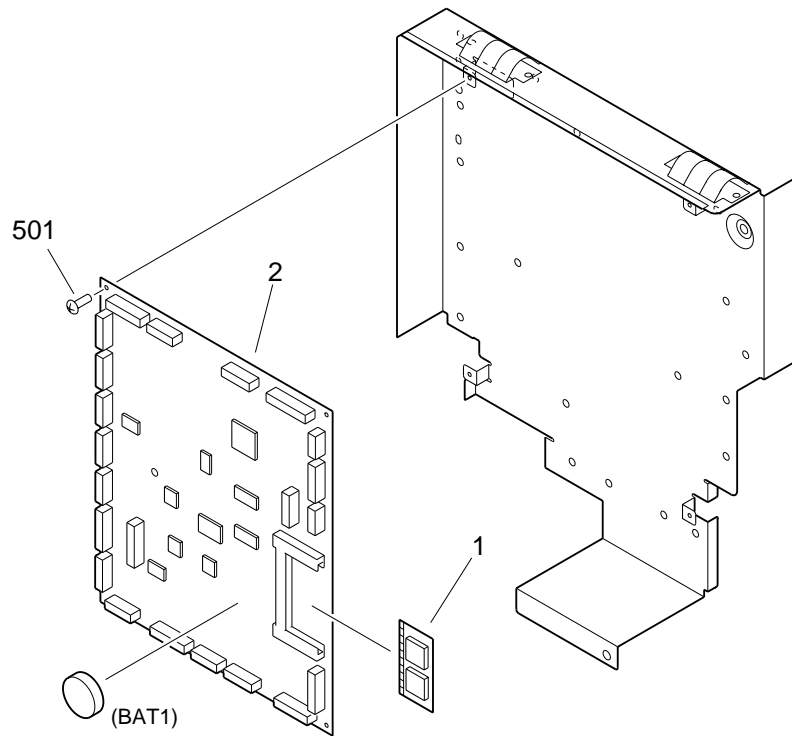

FIGURE & KEY NO.	PART NUMBER	RANK	QTY	DESCRIPTION	SERIAL NUMBER / REMARKS
930 -	NPN		RF	DC CONTROLLER PCB ASSEMBLY DCコントローラ回路基板	
1	FG6 - 8599 - 000		1	DIMM ASS'Y DIMM	
2	FG6 - 8609 - 000		1	DC CONTROLLER PCB ASSEMBLY DCコントローラ回路基板	
501	XB2 - 7400 - 607		4	SCREW,W/WASHER,M4X6 パネツキ バインド ネジ	
BAT1	WK1 - 0084 - 000		1	BATTERY, 3V, 550 MAH バッテリー	
FU103	VD5 - 0323 - 501		1	FUSE, 125V, 3.5A ヒューズ	
FU104	VD5 - 0323 - 501		1	FUSE, 125V, 3.5A ヒューズ	
FU105	VD5 - 0323 - 501		1	FUSE, 125V, 3.5A ヒューズ	
I C107	FH4 - 6156 - 000		1	IC, HG71G046A2R09FE,GATE ARRAY ゲート アレイ	
I C108	FH4 - 6123 - 000		1	IC, M38871M2-010GP, MCU MCU	
I C119	FH4 - 6104 - 000		1	IC, SLA517TH, GATE ARRAY ゲート アレイ	

FIGURE 935 READER CONTROL PCB ASSEMBLY

リーダコントローラ回路基板

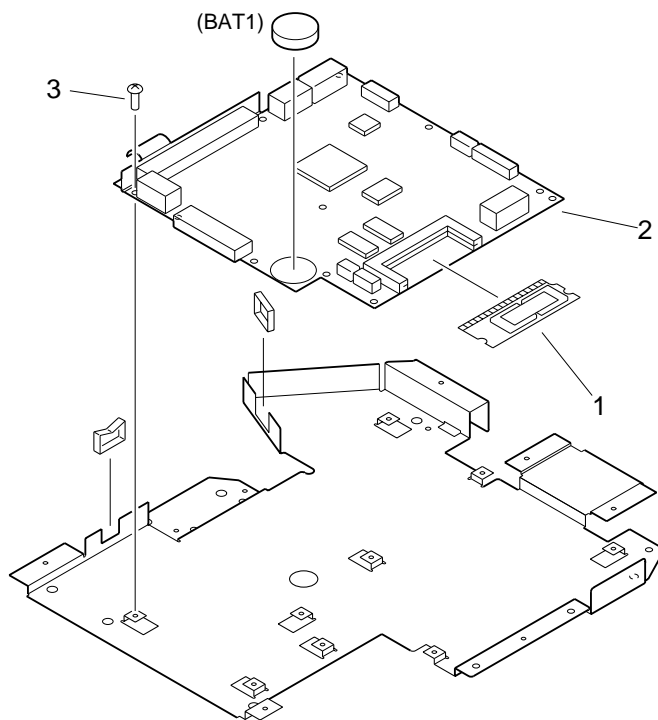
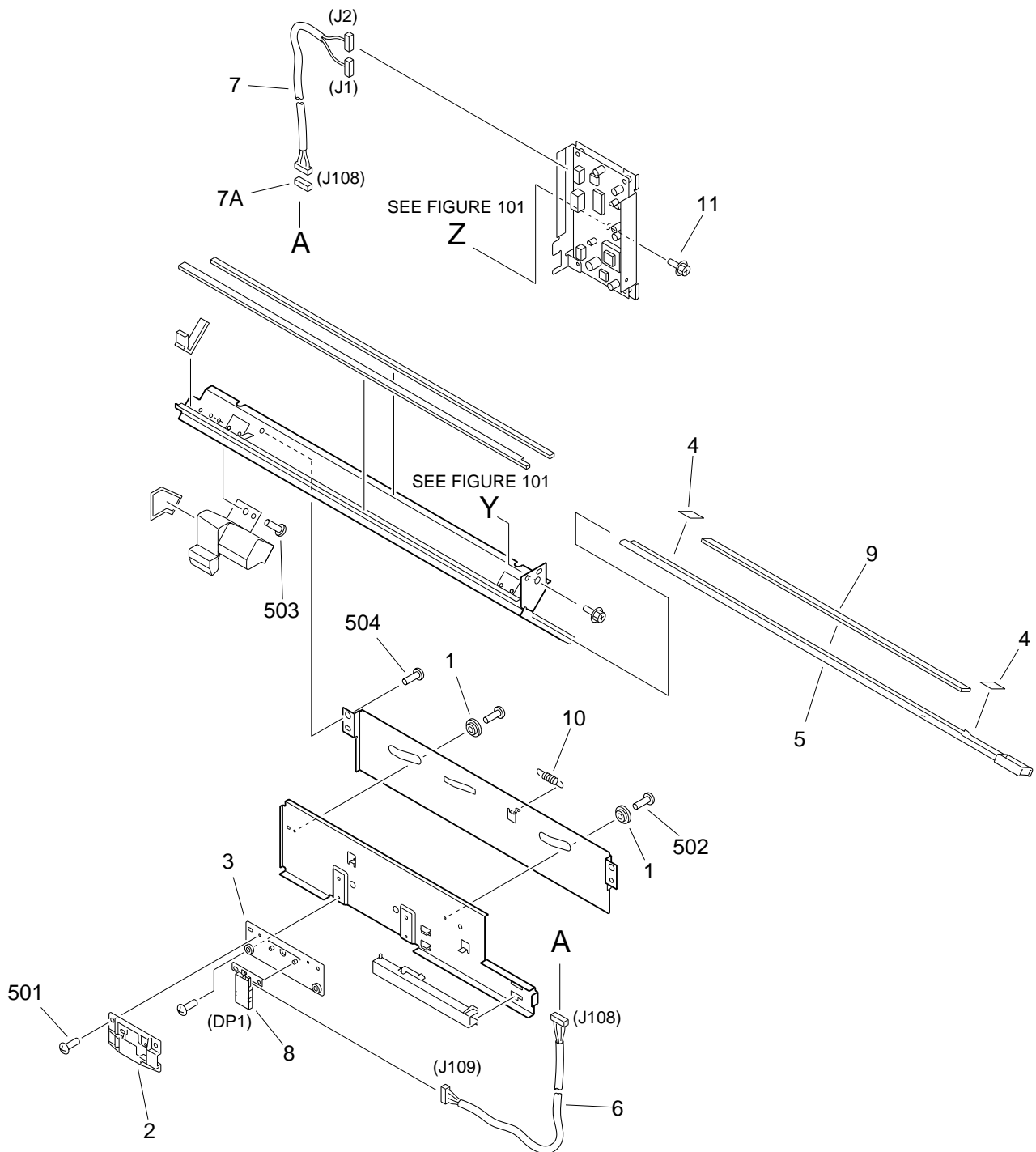

FIGURE & KEY NO.	PART NUMBER	RANK	QTY	DESCRIPTION	SERIAL NUMBER / REMARKS
935 -	NPN		RF	READER CONTROL PCB ASSEMBLY リーダ コントローラ回路基板	
1	FG3 - 1690 - 000		1	DIMM ASS'Y, MBM29F040C-90PFTN DIMM	
2	FG6 - 7405 - 000		1	READER CONTROL PCB ASSEMBLY リーダ コントローラ回路基板	
3	XA9 - 0265 - 000		2	SCREW,W/WASHER,TRUSS HEAD ザツキ バインド ネジ	
BAT1	WK1 - 0084 - 000		1	BATTERY, 3V, 550 MAH バッテリー	
IC 4	FH4 - 6135 - 000		1	IC, UPD65454GN-121, GATE ARRAY ゲート アレイ	
IC 5	FH4 - 6123 - 000		1	IC, M38871M2-010GP, MCU MCU	
IC18	FH4 - 6136 - 000		1	IC, MB87L1870, GATE ARRAY ゲート アレイ	

FIGURE 940 POTENTIAL MEASURING PCB ASSEMBLY 電位測定回路基板



NOTE: This assembly does not include the parts shown with key No. 4, 5, 9, and 11.
注: このユニットにKey No. 4、5、9、11の部品は含まれません。

FIGURE & KEY NO.	PART NUMBER	R A N K	Q' T Y	DESCRIPTION	SERIAL NUMBER / REMARKS
940 -	FG6 - 7428 - 000		1	POTENTIAL MEASURING PCB ASS'Y 電位測定回路基板	
1	FA4 - 8609 - 000		2	SPACER スペーサ	
2	FB4 - 1947 - 000		1	MOUNT, SENSOR, UPPER センサ台(上)	
3	FB4 - 1948 - 000		1	MOUNT, SENSOR, LOWER センサ台(下)	
4	FB4 - 9346 - 000		2	TAPE, GLASS ガラス接着テープ	SEE NOTE
5	FF5 - 7651 - 000		1	HOLDER, DUST-PROOF GLASS 防塵ガラス ホルダ	SEE NOTE
6	FG6 - 1884 - 000		1	CABLE, SENSOR CONNECTING 電位センサ中継束線	J108,109
7	FG6 - 1885 - 000		1	CABLE, POTENTIAL SENSOR 電位センサ束線	J1,2,108
7 A	VS1 - 5057 - 006		1	CONNECTOR, SNAP TIGHT チュウケイ コネクタ	J108
8	FH4 - 6019 - 000		1	POTENTIAL SENSOR UNIT 電位センサ ユニット	DP1 J109
9	FN5 - 4002 - 000		1	GLASS, DUST-PROOF 防塵ガラス	SEE NOTE
10	FS6 - 2759 - 000		1	SPRING, TENSION ヒツパリ パネ	
11	XA9 - 0643 - 000		2	SCREW,RS,M4X10 RS タイト ネジ	SEE NOTE
501	XB1 - 2300 - 609		4	SCREW,MACH.,TRUSS HEAD,M3X6 バインド ネジ	
502	XB1 - 2300 - 609		2	SCREW,MACH.,TRUSS HEAD,M3X6 バインド ネジ	
503	XB1 - 2400 - 609		1	SCREW,MACH.,TRUSS HEAD,M4X6 バインド ネジ	
504	XB1 - 2400 - 609		2	SCREW,MACH.,TRUSS HEAD,M4X6 バインド ネジ	
RA1	FH4 - 9181 - 000		1	RESISTOR ARRAY, 10MOHM 抵抗アレイ	
T1	FH3 - 0242 - 000		1	TRANSFORMER トランス	

FIGURE 945 INVERTER PCB ASSEMBLY

インバータ回路基板

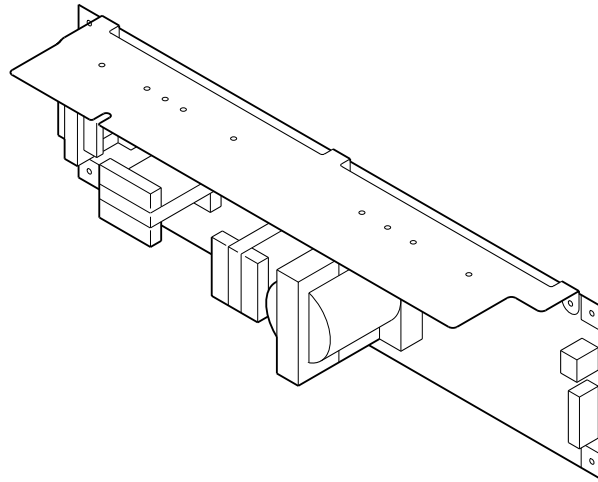

FIGURE & KEY NO.	PART NUMBER	RANK	QTY	DESCRIPTION	SERIAL NUMBER / REMARKS
945 -	FG6 - 2291 - 000		1	INVERTER PCB ASSEMBLY インバータ回路基板	
FU1001	VD7 - 1624 - 000		1	FUSE, 4A, 60V ヒューズ	
FU1002	VD7 - 1621 - 001		1	FUSE, 60V, 1A ヒューズ	
L1001	FH3 - 7203 - 000		1	INDUCTOR インダクタ	
L1002	FH3 - 7202 - 000		1	INDUCTOR インダクタ	
T1001	FH3 - 0879 - 000		1	TRANSFORMER トランス	
T1002	FH3 - 0666 - 000		1	TRANSFORMER トランス	
T1003	FH3 - 0881 - 000		1	TRANSFORMER トランス	

FIGURE 960 AC DRIVER PCB ASSEMBLY
ACドライバ回路基板

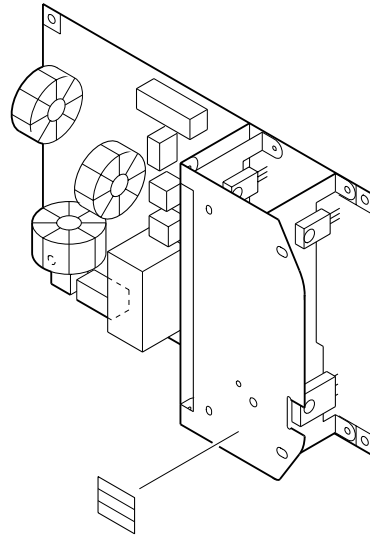

FIGURE & KEY NO.	PART NUMBER	RANK	QTY	DESCRIPTION	SERIAL NUMBER / REMARKS
960 -	FG6 - 7264 - 000		1	AC DRIVER PCB ASSEMBLY ACドライバ回路基板	
FU2	VD7 - 1832 - 501		1	FUSE, 2.5A 250V ヒューズ	
L1	FH3 - 0938 - 000		1	INDUCTOR インダクタ	
L2	FH3 - 0938 - 000		1	INDUCTOR インダクタ	
RL1	FH7 - 6331 - 000		1	RELAY リレー	
SK1	RH6 - 3434 - 000		1	FILTER, NOISE ノイズ フィルタ	
SK2	RH6 - 3434 - 000		1	FILTER, NOISE ノイズ フィルタ	
SK3	RH6 - 3434 - 000		1	FILTER, NOISE ノイズ フィルタ	
SK4	RH6 - 3434 - 000		1	FILTER, NOISE ノイズ フィルタ	
T1	FH3 - 0936 - 000		1	INDUCTOR インダクタ	

FIGURE 970 DOCUMENT DETECT PCB ASSEMBLY
原稿向き検出回路基板

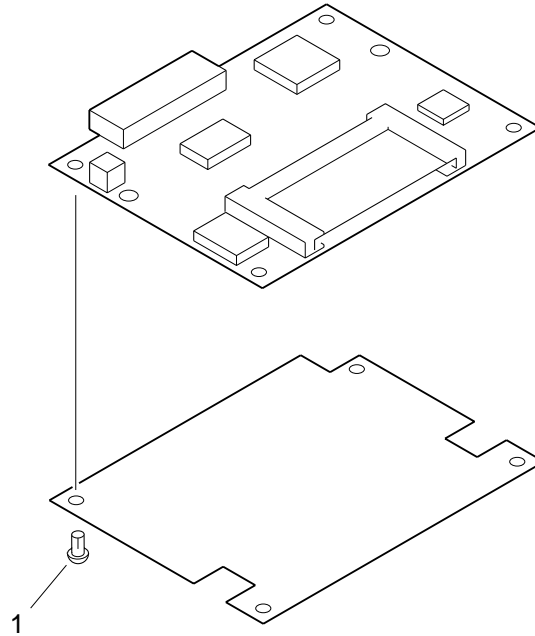
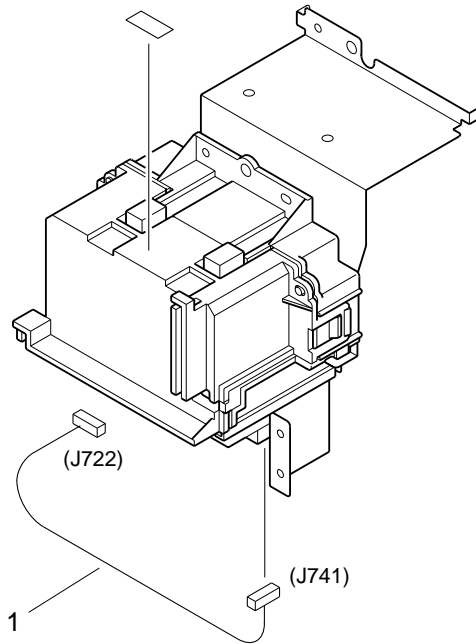

FIGURE & KEY NO.	PART NUMBER	RANK	QTY	DESCRIPTION	SERIAL NUMBER / REMARKS
970 -	FG6 - 7256 - 000		1	DOCUMENT DETECT PCB ASSEMBLY 原稿向き検出回路基板	
1	WT8 - 0053 - 000		4	RIVET, NYLON ナイロン リベット	
I C 2	FH4 - 5904 - 000		1	IC, MBCG46833-119, GATE ARRAY ゲート アレイ	
I C 3	FH4 - 5905 - 000		1	IC, MB87D119, GATE ARRAY ゲート アレイ	
I C 5	FH4 - 6154 - 000		1	IC, MB87L1890, GATE ARRAY ゲート アレイ	
I C 12	FH4 - 3882 - 000		1	IC, MR27V402E-013TP, MASK-ROM MASK - ROM	
I C 13	FH4 - 3883 - 000		1	IC, MR27V402E-038TP, MASK-ROM MASK - ROM	

FIGURE 980 H.V. AC TRANSFORMER PCB ASSEMBLY 高压ACトランス回路基板



NOTE: This assembly does not include the part shown with key No.1.
 注：このユニットにKey No. 1の部品は含まれません。

FIGURE & KEY NO.	PART NUMBER	RANK	QTY	DESCRIPTION	SERIAL NUMBER / REMARKS
980 -	FG6 - 7249 - 000		1	H.V. AC TRANSFORMER PCB ASS'Y 高压ACトランス回路基板	
1	FG6 - 7220 - 000		1	CABLE, H.V. CONNECTING 高压中継束線	J722,741 SEE NOTE
T1	FH3 - 5237 - 000		1	TRANSFORMER トランス	

FIGURE 985 H.V. DC TRANSFORMER PCB ASSEMBLY 高圧DCトランス回路基板

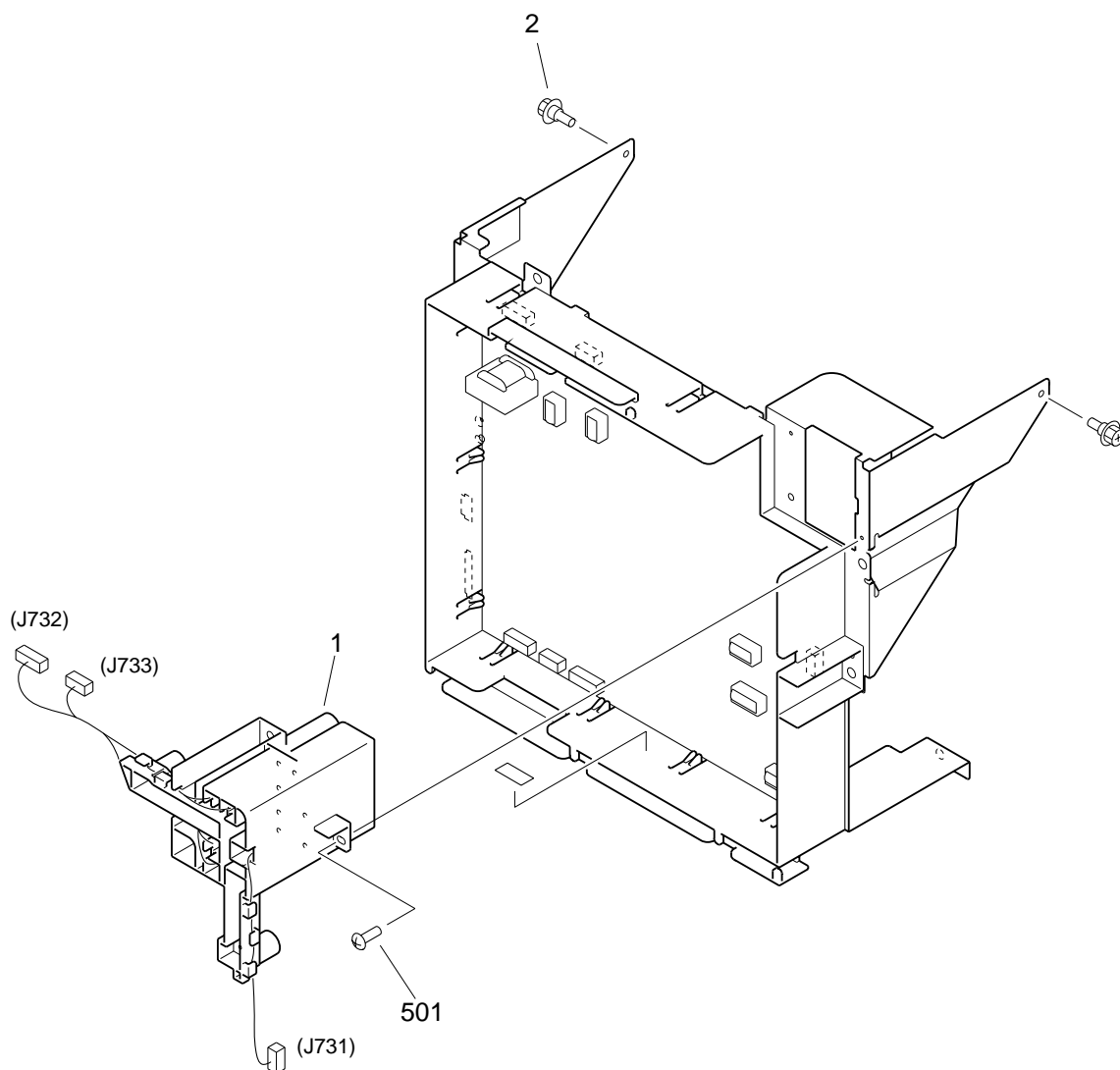

FIGURE & KEY NO.	PART NUMBER	RANK	QTY	DESCRIPTION	SERIAL NUMBER / REMARKS
985 -	FG6 - 8583 - 000		1	H.V. DC TRANSFORMER PCB ASS'Y 高圧DCトランス回路基板	J731-733
1	FH2 - 9231 - 000		1	JOINT CONNECTOR UNIT 連結コネクタ ユニット	
2	FS5 - 9214 - 000		2	SCREW,RS STEPPED,M4 RS タイト 段ビス	
501	XB1 - 2400 - 609		4	SCREW,MACH.,TRUSS HEAD,M4X6 バインド ネジ	
R206	FH4 - 9157 - 000		1	RESISTOR, 4MOHM, 1/4W 抵抗	
R551	FH6 - 3337 - 000		1	RESISTOR, 3MOHM, 1/3W 抵抗	
R561	FH6 - 3337 - 000		1	RESISTOR, 3MOHM, 1/3W 抵抗	
R571	FH6 - 3337 - 000		1	RESISTOR, 3MOHM, 1/3W 抵抗	
R581	FH6 - 3337 - 000		1	RESISTOR, 3MOHM, 1/3W 抵抗	
R851	FH6 - 3337 - 000		1	RESISTOR, 3MOHM, 1/3W 抵抗	
R857	FH6 - 3337 - 000		1	RESISTOR, 3MOHM, 1/3W 抵抗	
T101	FH3 - 0893 - 000		1	TRANSFORMER トランス	
T202	RH3 - 0071 - 000		1	TRANSFORMER トランス	
T301	FH3 - 0894 - 000		1	TRANSFORMER トランス	
T401	FH3 - 0894 - 000		1	TRANSFORMER トランス	
T501	FH3 - 0893 - 000		1	TRANSFORMER トランス	
T601	FH3 - 0766 - 000		1	TRANSFORMER トランス	
T701	FH3 - 0830 - 000		1	TRANSFORMER トランス	
T801	FH3 - 0893 - 000		1	TRANSFORMER トランス	

FIGURE B LIST OF CONNECTORS(1/4) コネクター一覧(1/4)

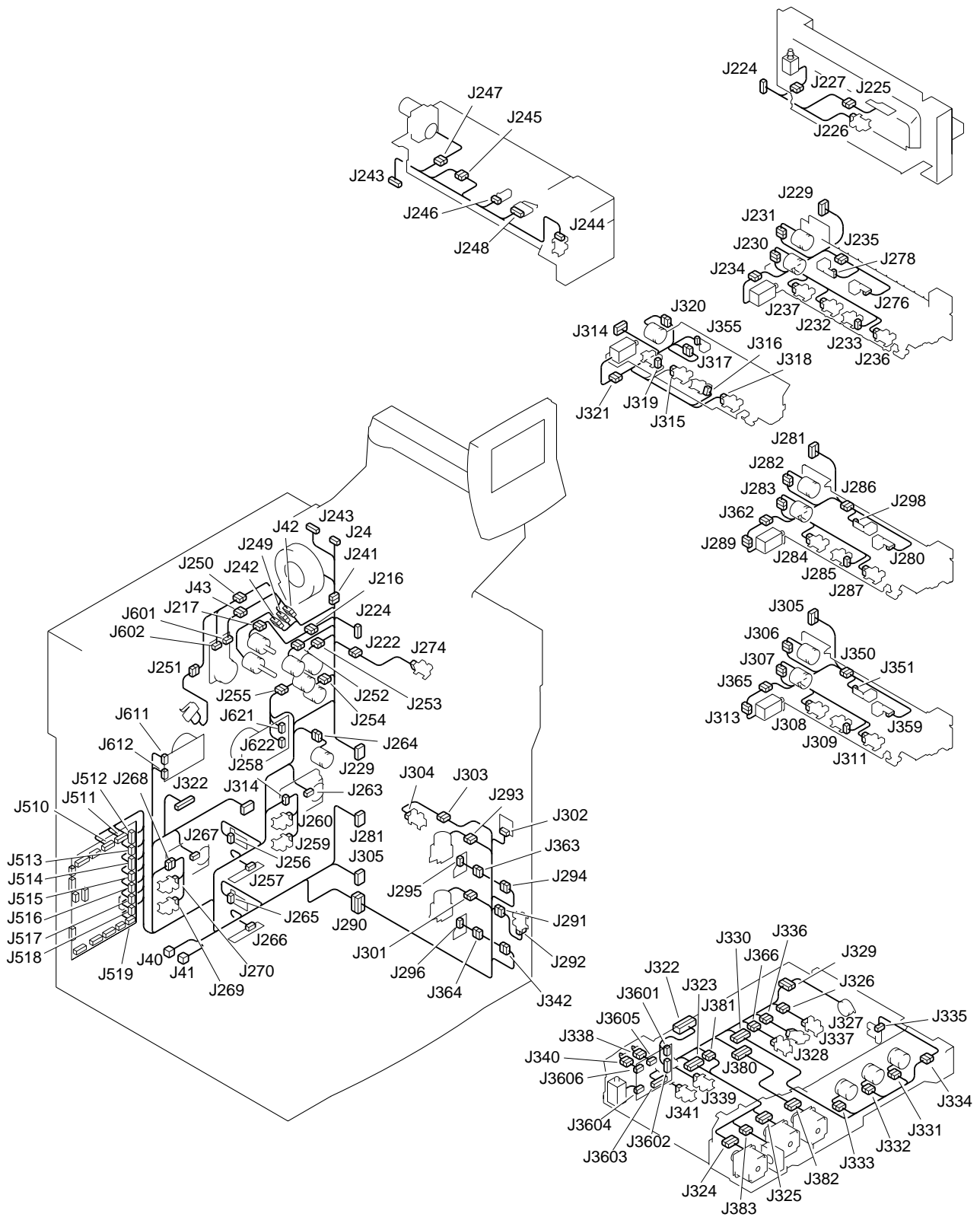

FIGURE B LIST OF CONNECTORS(3/4) コネクター一覧(3/4)

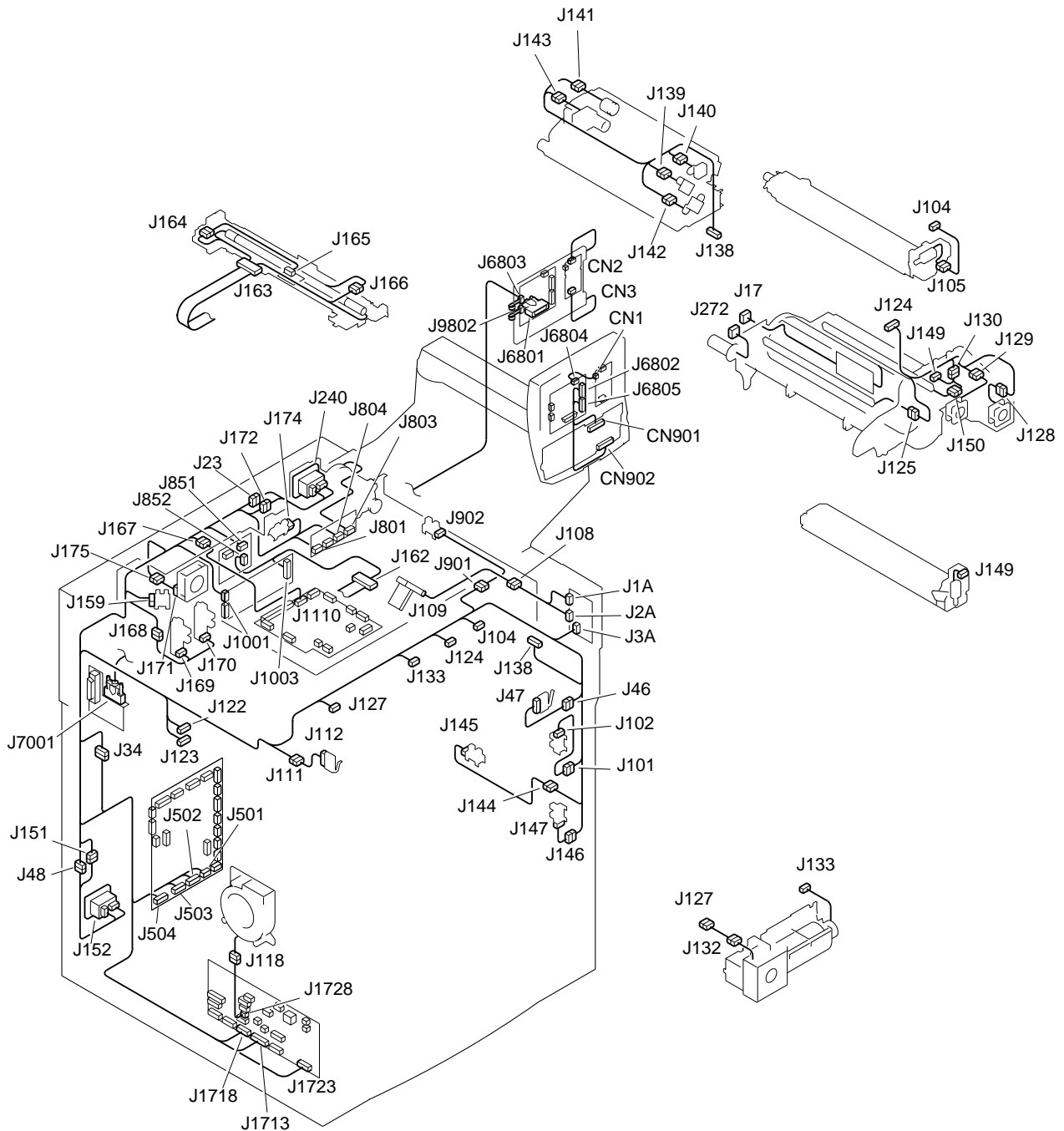

FIGURE B LIST OF CONNECTORS(4/4)

コネクター一覧(4/4)

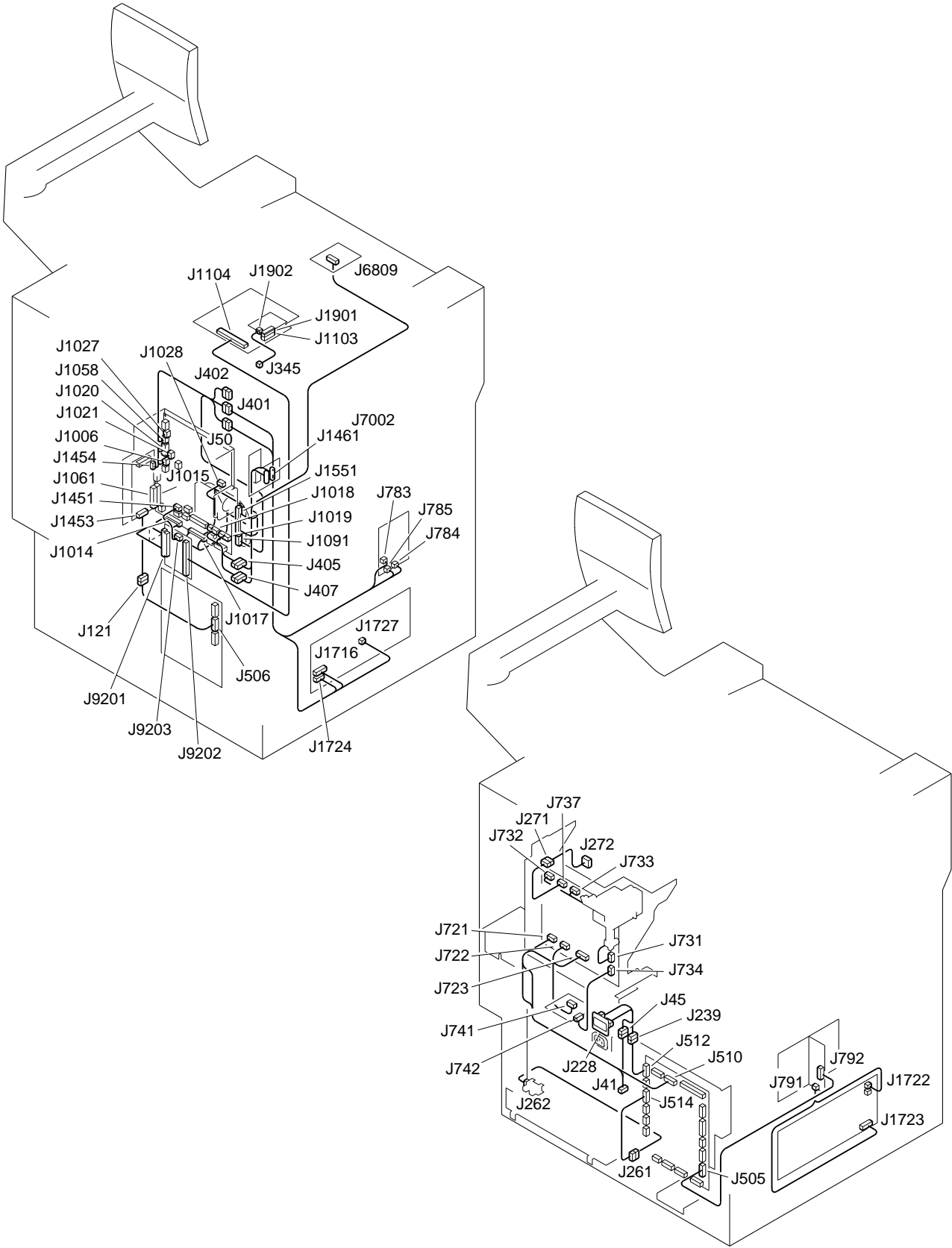

FIGURE & KEY NO.	PART NUMBER	RANK	QTY	DESCRIPTION	SERIAL NUMBER / REMARKS
B -	NPN		RF	LIST OF CONNECTORS コネクタ一覧	
CN 1	PCB			CONTROL PANEL INVERTER 操作部インバータ	
	VS1 - 0842 - 002		1	CONNECTOR, 2P, FEMALE コネクタ (メス)	
CN 2	PCB			CONTROL PANEL INVERTER 操作部インバータ	
	NPN			LCD CONTROL/ANALOG TOUCH PANEL 液晶パネル/アナログ タッチ パネル	
CN 3	PCB			CONTROL PANEL INVERTER 操作部インバータ	
	NPN			LCD CONTROL/ANALOG TOUCH PANEL 液晶パネル/アナログ タッチ パネル	
CN901	PCB			CONTROL PANEL KEY 操作キー	
	VS1 - 6023 - 015		1	CONNECTOR, 15P, MALE コネクタ (オス)	
CN902	PCB			CONTROL PANEL KEY 操作キー	
J 1	VS1 - 6023 - 014		1	CONNECTOR, 14P, MALE コネクタ (オス)	
	PCB			POTENTIAL MEASURING 電位制御	
	VS1 - 0279 - 005		1	CONNECTOR, 5P, FEMALE コネクタ (メス)	
	WS3 - 0437 - 000		3	SOCKET CONTACT, 20-30AWG ソケット コンタクト	
	PCB			AC DRIVER ACドライバ	
J 2	VS1 - 6380 - 003		1	CONNECTOR, 3P, MALE コネクタ (オス)	
	WS3 - 5472 - 000		2	SOCKET CONTACT, 12AWG ソケット コンタクト	
	PCB			POTENTIAL MEASURING 電位制御	
	VS1 - 0279 - 004		1	CONNECTOR, 4P, FEMALE コネクタ (メス)	
	WS3 - 0469 - 000		3	SOCKET CONTACT, 26-30AWG ソケット コンタクト	
J 3	PCB			AC DRIVER ACドライバ	
	VS3 - 5083 - 007		1	CONNECTOR, 7P, FEMALE コネクタ (メス)	
	WS3 - 5160 - 000		2	SOCKET CONTACT, 18-24AWG ソケット コンタクト	
	PCB			POTENTIAL MEASURING 電位制御	
	VS1 - 6321 - 004		1	CONNECTOR, 4P, FEMALE コネクタ (メス)	
J 4	PCB			AC DRIVER ACドライバ	
	VS3 - 5083 - 003		1	CONNECTOR, 3P, FEMALE コネクタ (メス)	
	WS3 - 5160 - 000		3	SOCKET CONTACT, 18-24AWG ソケット コンタクト	
	PCB			AC DRIVER ACドライバ	
	VS1 - 6380 - 002		1	CONNECTOR, 2P, MALE コネクタ (オス)	

FIGURE & KEY NO.	PART NUMBER	RANK	QTY	DESCRIPTION	SERIAL NUMBER / REMARKS
B - J 4	WS3 - 5292 - 000		2	SOCKET CONTACT ソケット コンタクト	
J 5	PCB			AC DRIVER ACドライバ	
	VS3 - 5083 - 011		1	CONNECTOR, 11P, FEMALE コネクタ (メス)	
	WS3 - 5160 - 000		6	SOCKET CONTACT, 18-24AWG ソケット コンタクト	
J 6	PCB			AC DRIVER ACドライバ	
	VS1 - 6380 - 004		1	CONNECTOR, 4P, MALE コネクタ (オス)	
	WS3 - 5292 - 000		3	SOCKET CONTACT ソケット コンタクト	
J 11	FG6 - 1904 - 000		1	CABLE, FIXING DRAWER CONNECT 定着ドロア中継束線	
	VS3 - 5121 - 003		1	CONNECTOR, 3P, FEMALE コネクタ (メス)	
	WS3 - 5291 - 000		3	PIN CONTACT ピン コンタクト	
J 12	VS1 - 6380 - 004		1	CONNECTOR, 4P, MALE コネクタ (オス)	
	VS3 - 5121 - 004		1	CONNECTOR, 4P, FEMALE コネクタ (メス)	
	WS3 - 5291 - 000		4	PIN CONTACT ピン コンタクト	
	WS3 - 5292 - 000		4	SOCKET CONTACT ソケット コンタクト	
J 13	VS1 - 6380 - 004		1	CONNECTOR, 4P, MALE コネクタ (オス)	
	VS3 - 5121 - 004		1	CONNECTOR, 4P, FEMALE コネクタ (メス)	
	WS3 - 5291 - 000		4	PIN CONTACT ピン コンタクト	
	WS3 - 5292 - 000		4	SOCKET CONTACT ソケット コンタクト	
J 14	FG6 - 7201 - 000		1	CABLE, DRUM HEATER CONNECTING ドラム ヒータ中継束線	
	VS4 - 0002 - 003		1	CONNECTOR, 3P, FEMALE コネクタ (メス)	
J 15	WS4 - 0217 - 000		2	SOCKET CONTACT, 22-18AWG ソケット コンタクト	
	FG6 - 1875 - 000		1	CABLE, AC, FIXING/FEEDER 定着 / 搬送AC束線	
	FG6 - 1904 - 000		1	CABLE, FIXING DRAWER CONNECT 定着ドロア中継束線	
J 16	NPN			MAIN SWITCH メイン スイッチ	SW1
	RH2 - 5339 - 000		1	CONNECTOR, 4P, FEMALE ハウジング	
J 17	WT1 - 0579 - 000		4	RECEPTACLE リセプタクル	
	FG6 - 1853 - 000		1	CABLE, DRUM HEATER ドラム ヒータ中継束線	
	FG6 - 7201 - 000		1	CABLE, DRUM HEATER CONNECTING ドラム ヒータ中継束線	
J 18	VS4 - 0001 - 003		1	CONNECTOR, 3P, MALE コネクタ (オス)	
	VS4 - 0002 - 003		1	CONNECTOR, 3P, FEMALE コネクタ (メス)	

FIGURE & KEY NO.	PART NUMBER	RANK	QTY	DESCRIPTION	SERIAL NUMBER / REMARKS	
B - J 18	WS4 - 0217 - 000		2	SOCKET CONTACT, 22-18AWG ソケット コンタクト	H4	
	WS4 - 0219 - 000		2	PIN CONTACT, 18-22AWG ピン コンタクト		
	J 19	NPN				CASSETTE HEATER カセット ヒータ
		VS4 - 0001 - 003		1		CONNECTOR, 3P, MALE コネクタ (オス)
		WS4 - 0219 - 000		2		PIN CONTACT, 18-22AWG ピン コンタクト
J 20	VS4 - 0001 - 002		1	CONNECTOR, 2P, MALE コネクタ (オス)		
	VS4 - 0002 - 002		1	CONNECTOR, 2P, FEMALE コネクタ (メス)		
	WS4 - 0217 - 000		2	SOCKET CONTACT, 22-18AWG ソケット コンタクト		
	WS4 - 0219 - 000		2	PIN CONTACT, 18-22AWG ピン コンタクト		
J 21	VS4 - 0001 - 002		1	CONNECTOR, 2P, MALE コネクタ (オス)		
J 23	VS4 - 0002 - 002		1	CONNECTOR, 2P, FEMALE コネクタ (メス)		
	WS4 - 0218 - 000		2	SOCKET CONTACT, 22-26AWG ソケット コンタクト		
	WS4 - 0220 - 000		2	PIN CONTACT, 22-26AWG ピン コンタクト		
	VS1 - 5729 - 002		1	CONNECTOR, 2P, MALE コネクタ (オス)		
	VS3 - 5083 - 002		1	CONNECTOR, 2P, FEMALE コネクタ (メス)		
J 24	WS3 - 5160 - 000		2	SOCKET CONTACT, 18-24AWG ソケット コンタクト		
	WS3 - 5301 - 000		2	PIN CONTACT ピン コンタクト		
	VS1 - 6380 - 004		1	CONNECTOR, 4P, MALE コネクタ (オス)		
	VS3 - 5121 - 004		1	CONNECTOR, 4P, FEMALE コネクタ (メス)		
	WS3 - 5291 - 000		3	PIN CONTACT ピン コンタクト		
J 25	WS3 - 5292 - 000		3	SOCKET CONTACT ソケット コンタクト		
	VS4 - 0001 - 003		1	CONNECTOR, 3P, MALE コネクタ (オス)		
	VS4 - 0002 - 003		1	CONNECTOR, 3P, FEMALE コネクタ (メス)		
	WS4 - 0217 - 000		2	SOCKET CONTACT, 22-18AWG ソケット コンタクト		
	WS4 - 0219 - 000		2	PIN CONTACT, 18-22AWG ピン コンタクト		
J 26	VS1 - 6380 - 002		1	CONNECTOR, 2P, MALE コネクタ (オス)		
	VS3 - 5121 - 002		1	CONNECTOR, 2P, FEMALE コネクタ (メス)		
	WS3 - 5472 - 000		2	SOCKET CONTACT, 12AWG ソケット コンタクト		
	WS3 - 5473 - 000		2	PIN, CONTACT, 12AWG ピンコンタクト		
J 28	VS1 - 5729 - 007		1	CONNECTOR, 7P, MALE コネクタ (オス)		

FIGURE & KEY NO.	PART NUMBER	R A N K	Q' T Y	DESCRIPTION	SERIAL NUMBER / REMARKS
B - J 28	VS3 - 5083 - 007		1	CONNECTOR, 7P, FEMALE コネクタ (メス)	
	WS3 - 5160 - 000		4	SOCKET CONTACT, 18-24AWG ソケット コンタクト	
J 32	WS3 - 5301 - 000		4	PIN CONTACT ピン コンタクト	
	VS1 - 6373 - 008		1	CONNECTOR, 8P, FEMALE コネクタ (メス)	
	VS1 - 6490 - 008		1	CONNECTOR, 8P, MALE コネクタ (オス)	
J 34	WS3 - 5598 - 000		8	PIN CONTACT ピン コンタクト	
	WS3 - 5680 - 000		8	SOCKET CONTACT, 20-24AWG ソケット コンタクト	
	VS4 - 0001 - 015		1	CONNECTOR, 15P, MALE コネクタ (オス)	
	VS4 - 0002 - 015		1	CONNECTOR, 15P, FEMALE コネクタ (メス)	
	WS4 - 0217 - 000		15	SOCKET CONTACT, 22-18AWG ソケット コンタクト	
J 35	WS4 - 0219 - 000		15	PIN CONTACT, 18-22AWG ピン コンタクト	
	VS1 - 6372 - 008		1	CONNECTOR, 8P, MALE コネクタ (オス)	
	VS1 - 6373 - 008		1	CONNECTOR, 8P, FEMALE コネクタ (メス)	
	WS3 - 5598 - 000		8	PIN CONTACT ピン コンタクト	
	WS3 - 5680 - 000		8	SOCKET CONTACT, 20-24AWG ソケット コンタクト	
J 37	VS1 - 6372 - 002		1	CONNECTOR, 2P, MALE コネクタ (オス)	
	VS1 - 6373 - 002		1	CONNECTOR, 2P, FEMALE コネクタ (メス)	
	WS3 - 5598 - 000		2	PIN CONTACT ピン コンタクト	
	WS3 - 5680 - 000		2	SOCKET CONTACT, 20-24AWG ソケット コンタクト	
J 40	VS4 - 0001 - 006		1	CONNECTOR, 6P, MALE コネクタ (オス)	
J 41	VS4 - 0002 - 006		1	CONNECTOR, 6P, FEMALE コネクタ (メス)	
	WS4 - 0217 - 000		5	SOCKET CONTACT, 22-18AWG ソケット コンタクト	
	WS4 - 0220 - 000		6	PIN CONTACT, 22-26AWG ピン コンタクト	
	VS4 - 0001 - 012		1	CONNECTOR, 12P, MALE コネクタ (オス)	
	VS4 - 0002 - 012		1	CONNECTOR, 12P, FEMALE コネクタ (メス)	
J 42	WS4 - 0217 - 000		11	SOCKET CONTACT, 22-18AWG ソケット コンタクト	
	WS4 - 0220 - 000		11	PIN CONTACT, 22-26AWG ピン コンタクト	
	VS1 - 5729 - 002		1	CONNECTOR, 2P, MALE コネクタ (オス)	
	VS3 - 5083 - 002		1	CONNECTOR, 2P, FEMALE コネクタ (メス)	
	WS3 - 5160 - 000		2	SOCKET CONTACT, 18-24AWG ソケット コンタクト	

FIGURE & KEY NO.	PART NUMBER	RANK	QTY	DESCRIPTION	SERIAL NUMBER / REMARKS
B - J 42	WS3 - 5301 - 000		2	PIN CONTACT ピン コンタクト	
J 43	VS1 - 5729 - 002		1	CONNECTOR, 2P, MALE コネクタ (オス)	
	VS3 - 5083 - 002		1	CONNECTOR, 2P, FEMALE コネクタ (メス)	
	WS3 - 5160 - 000		2	SOCKET CONTACT, 18-24AWG ソケット コンタクト	
	WS3 - 5301 - 000		2	PIN CONTACT ピン コンタクト	
J 45	VS4 - 0001 - 004		1	CONNECTOR, 4P, MALE コネクタ (オス)	
	VS4 - 0002 - 004		1	CONNECTOR, 4P, FEMALE コネクタ (メス)	
	WS4 - 0218 - 000		3	SOCKET CONTACT, 22-26AWG ソケット コンタクト	
	WS4 - 0219 - 000		3	PIN CONTACT, 18-22AWG ピン コンタクト	
J 46	VS1 - 5729 - 002		1	CONNECTOR, 2P, MALE コネクタ (オス)	
	VS3 - 5083 - 002		1	CONNECTOR, 2P, FEMALE コネクタ (メス)	
	WS3 - 5160 - 000		2	SOCKET CONTACT, 18-24AWG ソケット コンタクト	
	WS3 - 5301 - 000		2	PIN CONTACT ピン コンタクト	
J 47	NPN			MULTI DOOR INTERLOCK SWITCH マルチ扉インターロック スイッチ	MSW5
	RH2 - 5283 - 000		1	CONNECTOR, 3P, FEMALE コネクタ (メス)	
J 48	WS3 - 5419 - 000		2	SOCKET CONTACT, 22-26AWG ソケット コンタクト	
	VS1 - 5057 - 002		1	CONNECTOR, SNAP TIGHT チュウケイ コネクタ	
	VS1 - 5824 - 002		1	CONNECTOR, 2P, FEMALE コネクタ (メス)	
	VS1 - 6321 - 002		1	CONNECTOR, 2P, FEMALE コネクタ (メス)	
	WS3 - 5358 - 000		2	SOCKET CONTACT, 22-26AWG ソケット コンタクト	
J 50	VS1 - 6694 - 030		1	CONNECTOR, 30P, MALE コネクタ (オス)	
	VS1 - 6695 - 030		1	CONNECTOR, 30P, FEMALE コネクタ (メス)	
	WS3 - 5680 - 000		28	SOCKET CONTACT, 20-24AWG ソケット コンタクト	
	WS3 - 5719 - 000		28	PIN CONTACT, 20-24AWG ピン コンタクト	
J 51	VS1 - 6302 - 002		1	CONNECTOR, 2P, FEMALE コネクタ (メス)	
	VS1 - 6702 - 002		1	CONNECTOR, 2P, FEMALE コネクタ (メス)	
	WS3 - 5569 - 000		1	SOCKET CONTACT, 22-28AWG ソケット コンタクト	
	WS3 - 5720 - 000		1	SOCKET CONTACT, 22-28AWG ソケット コンタクト	
J 56	VS1 - 5729 - 002		1	CONNECTOR, 2P, MALE コネクタ (オス)	
	VS3 - 5083 - 002		1	CONNECTOR, 2P, FEMALE コネクタ (メス)	

FIGURE & KEY NO.	PART NUMBER	RANK	QTY	DESCRIPTION	SERIAL NUMBER / REMARKS	
B - J 56	WS3 - 5160 - 000		2	SOCKET CONTACT, 18-24AWG ソケット コンタクト	PS56	
	WS3 - 5301 - 000		2	PIN CONTACT ピン コンタクト		
J 101	VS1 - 5057 - 003		1	CONNECTOR, SNAP TIGHT チュウケイ コネクタ		
	VS1 - 6321 - 003		2	CONNECTOR, 3P, FEMALE コネクタ (メス)		
J 102	NPN		MULTI DOOR OPEN/CLOSE SENSOR マルチ扉開閉センサ			
J 103	VS1 - 6321 - 003		1	CONNECTOR, 3P, FEMALE コネクタ (メス)		FM4
	NPN			FEED/READ FAN 流し読みファン		
	VS1 - 6321 - 003		1	CONNECTOR, 3P, FEMALE コネクタ (メス)		
J 104	VS1 - 5057 - 002		1	CONNECTOR, SNAP TIGHT チュウケイ コネクタ		
	VS1 - 6321 - 002		2	CONNECTOR, 2P, FEMALE コネクタ (メス)		
J 105	NPN			PRIMARY CLEANING MOTOR 一次清掃モータ	M8	
	VS1 - 5057 - 002		1	CONNECTOR, SNAP TIGHT チュウケイ コネクタ		
	VS1 - 6321 - 002		1	CONNECTOR, 2P, FEMALE コネクタ (メス)		
J 108	VS1 - 0842 - 006		1	CONNECTOR, 6P, FEMALE コネクタ (メス)		
	VS1 - 5057 - 006		1	CONNECTOR, SNAP TIGHT チュウケイ コネクタ		
J 109	VS1 - 5824 - 006		1	CONNECTOR, 6P, FEMALE コネクタ (メス)	DP1	
	WS3 - 5358 - 000		6	SOCKET CONTACT, 22-26AWG ソケット コンタクト		
	NPN			VOLTAGE SENSOR 電位センサ		
	VS3 - 5203 - 005		1	CONNECTOR, 5P, MALE コネクタ (オス)		
	WS3 - 5365 - 000		5	PIN CONTACT, 28-32AWG ピン コンタクト		
J 111	VS1 - 5057 - 002		1	CONNECTOR, SNAP TIGHT チュウケイ コネクタ	MSW7	
	VS1 - 6321 - 002		2	CONNECTOR, 2P, FEMALE コネクタ (メス)		
J 112	NPN			FRONT DOOR OPEN/CLOSE SWITCH 前扉開閉スイッチ		
	RH2 - 5283 - 000		1	CONNECTOR, 3P, FEMALE コネクタ (メス)		
	WS3 - 5419 - 000		2	SOCKET CONTACT, 22-26AWG ソケット コンタクト		
J 113	NPN			LASER DRIVER COOLING FAN レーザ ドライバ冷却ファン	FM5	
	VS1 - 5057 - 003		1	CONNECTOR, SNAP TIGHT チュウケイ コネクタ		
	VS1 - 6321 - 003		1	CONNECTOR, 3P, FEMALE コネクタ (メス)		
J 114	VS1 - 5057 - 003		1	CONNECTOR, SNAP TIGHT チュウケイ コネクタ		
	VS1 - 6321 - 003		2	CONNECTOR, 3P, FEMALE コネクタ (メス)		

FIGURE & KEY NO.	PART NUMBER	RANK	QTY	DESCRIPTION	SERIAL NUMBER / REMARKS
B - J 115	NPN			FIXING EXHAUST FAN 定着排熱ファン	FM2
	VS1 - 6321 - 003		1	CONNECTOR, 3P, FEMALE コネクタ (メス)	
	J 116	VS1 - 5057 - 004	1	CONNECTOR, SNAP TIGHT チュウケイ コネクタ	
J 118	VS1 - 6321 - 004		2	CONNECTOR, 4P, FEMALE コネクタ (メス)	FM17
	NPN			DELIVERY FAN 1 排紙ファン (1)	
J 119	VS1 - 5057 - 003		1	CONNECTOR, SNAP TIGHT チュウケイ コネクタ	SIZE1
	VS1 - 6321 - 003		1	CONNECTOR, 3P, FEMALE コネクタ (メス)	
	NPN			PAPER SIZE SENSOR 1 紙サイズ検知 (1)	
	VS1 - 5057 - 003		1	CONNECTOR, SNAP TIGHT チュウケイ コネクタ	
	VS1 - 6320 - 003		1	CONNECTOR, 3P, FEMALE コネクタ (メス)	
J 120	NPN			PAPER SIZE SENSOR 2 紙サイズ検知 (2)	SIZE2
	VS1 - 5057 - 003		1	CONNECTOR, SNAP TIGHT チュウケイ コネクタ	
	VS1 - 6321 - 003		1	CONNECTOR, 3P, FEMALE コネクタ (メス)	
J 121	VS1 - 6313 - 014		2	CONNECTOR, 14P, FEMALE コネクタ (メス)	
	VS1 - 6314 - 014		2	CONNECTOR, 14P, FEMALE コネクタ (メス)	
J 122	VS1 - 6319 - 028		1	CONNECTOR, SNAP TIGHT チュウケイ コネクタ	FM20
	VT2 - 5161 - 028		1	HOLDER, CONNECTOR, 28P コネクタ ホルダ	
	NPN			FIXING EXHAUST FAN 定着排熱ファン	
	VS1 - 6321 - 003		1	CONNECTOR, 3P, FEMALE コネクタ (メス)	
J 124	VS1 - 6314 - 014		2	CONNECTOR, 14P, FEMALE コネクタ (メス)	
J 125	VS1 - 6318 - 014		1	CONNECTOR, SNAP TIGHT 中継コネクタ	LED1
	NPN			PRE-CONDITIONING EXPOSURE LED 前露光LED	
	VS1 - 6321 - 002		1	CONNECTOR, 2P, FEMALE コネクタ (メス)	
J 127	VS1 - 5057 - 003		1	CONNECTOR, SNAP TIGHT チュウケイ コネクタ	
	VS1 - 6321 - 003		2	CONNECTOR, 3P, FEMALE コネクタ (メス)	
J 128	NPN			PRE-TRANSFER FAN 転写前ファン	FM10
	VS1 - 6321 - 003		1	CONNECTOR, 3P, FEMALE コネクタ (メス)	
J 129	NPN			DEVELOPMENT FAN 現像ファン	FM15
	VS1 - 5057 - 003		1	CONNECTOR, SNAP TIGHT チュウケイ コネクタ	
	VS1 - 6321 - 003		1	CONNECTOR, 3P, FEMALE コネクタ (メス)	

FIGURE & KEY NO.	PART NUMBER	RANK	QTY	DESCRIPTION	SERIAL NUMBER / REMARKS
B - J 130	VS1 - 5057 - 004		1	CONNECTOR, SNAP TIGHT チュウケイ コネクタ	
	VS1 - 6321 - 004		2	CONNECTOR, 4P, FEMALE コネクタ (メス)	
J 132	NPN			SCANNER COOLING FAN 光学冷却ファン	FM3
	VS1 - 6321 - 003		1	CONNECTOR, 3P, FEMALE コネクタ (メス)	
J 133	NPN			PRIMARY CORONA FAN 一次帯電ファン	FM1
J 135	VS1 - 5057 - 003		1	CONNECTOR, SNAP TIGHT チュウケイ コネクタ	
	VS1 - 6321 - 003		1	CONNECTOR, 3P, FEMALE コネクタ (メス)	
	VS1 - 6314 - 006		2	CONNECTOR, 6P, FEMALE コネクタ (メス)	
	VS1 - 6318 - 006		1	CONNECTOR, SNAP TIGHT チュウケイ コネクタ	
J 136	NPN			PAPER SIZE SENSOR, 3 紙サイズ検知 (3)	SIZE3
J 137	VS1 - 5057 - 003		1	CONNECTOR, SNAP TIGHT チュウケイ コネクタ	SIZE4
	VS1 - 6321 - 003		1	CONNECTOR, 3P, FEMALE コネクタ (メス)	
	NPN			PAPER SIZE SENSOR, 4 紙サイズ検知 (4)	
	VS1 - 5057 - 003		1	CONNECTOR, SNAP TIGHT チュウケイ コネクタ	
	VS1 - 6321 - 003		1	CONNECTOR, 3P, FEMALE コネクタ (メス)	
J 138	VS1 - 6314 - 013		2	CONNECTOR, 13P, FEMALE コネクタ (メス)	TS1
J 139	VS1 - 6318 - 013		1	CONNECTOR, SNAP TIGHT チュウケイ コネクタ	
	NPN			BUFFER TONER SENSOR バッファ残量検知	
	VS1 - 5057 - 003		1	CONNECTOR, SNAP TIGHT チュウケイ コネクタ	
	VS1 - 6321 - 003		1	CONNECTOR, 3P, FEMALE コネクタ (メス)	
J 140	NPN			BUFFER TONER EMPTYNESS SENSOR バッファ空検知	TS2
	VS1 - 5057 - 003		1	CONNECTOR, SNAP TIGHT チュウケイ コネクタ	
	VS1 - 6321 - 003		1	CONNECTOR, 3P, FEMALE コネクタ (メス)	
J 141	NPN			BUFFER CLUTCH バッファクラッチ	CL1
	VS1 - 5057 - 002		1	CONNECTOR, SNAP TIGHT チュウケイ コネクタ	
J 142	VS1 - 6321 - 002		1	CONNECTOR, 2P, FEMALE コネクタ (メス)	TS3
	NPN			DEVELOPING TONER SENSOR 現像トナー センサ	
	VS1 - 5057 - 003		1	CONNECTOR, SNAP TIGHT チュウケイ コネクタ	
J 143	VS1 - 6321 - 003		1	CONNECTOR, 3P, FEMALE コネクタ (メス)	M18
	NPN			BUFFER MOTOR バッファモータ	

FIGURE & KEY NO.	PART NUMBER	RANK	QTY	DESCRIPTION	SERIAL NUMBER / REMARKS	
B - J 143	VS1 - 5057 - 002		1	CONNECTOR, SNAP TIGHT チュウケイ コネクタ	PS47	
	VS1 - 6321 - 002		1	CONNECTOR, 2P, FEMALE コネクタ (メス)		
J 144	VS1 - 5057 - 003		1	CONNECTOR, SNAP TIGHT チュウケイ コネクタ		
	VS1 - 6321 - 003		2	CONNECTOR, 3P, FEMALE コネクタ (メス)		
J 145	NPN		VERTICAL PATH SENSOR 1 縦パス センサ (1)			
J 146	VS1 - 6321 - 003		1	CONNECTOR, 3P, FEMALE コネクタ (メス)		PS58
	VS1 - 5057 - 004		1	CONNECTOR, SNAP TIGHT チュウケイ コネクタ		
	VS1 - 6321 - 004		2	CONNECTOR, 4P, FEMALE コネクタ (メス)		
	NPN			RIGHT DOOR UPPER OPEN SENSOR 右扉上開閉センサ		
	VS1 - 6321 - 003		1	CONNECTOR, 3P, FEMALE コネクタ (メス)		
J 149	NPN		PRE-TRANSFER CLEANING MOTOR 転写前清掃モータ	M7		
	VS1 - 6321 - 002		1	CONNECTOR, 2P, FEMALE コネクタ (メス)	LED2	
J 150	NPN		POST EXPOSURE LED ポスト露光LED			
	VS1 - 6321 - 002		1	CONNECTOR, 2P, FEMALE コネクタ (メス)		
J 151	VS1 - 5057 - 005		1	CONNECTOR, SNAP TIGHT チュウケイ コネクタ		
J 152	VS1 - 6321 - 005		2	CONNECTOR, 5P, FEMALE コネクタ (メス)	ACCESSORY	
	SYS			TO FINISHER フィニッシャ		
	FH2 - 6480 - 000		1	CONNECTOR, FEMALE コネクタ (メス)		
	VS1 - 5452 - 007		1	CONNECTOR, 7P, FEMALE コネクタ (メス)		
J 155	VS1 - 6314 - 006		2	CONNECTOR, 6P, FEMALE コネクタ (メス)		
	VS1 - 6318 - 006		1	CONNECTOR, SNAP TIGHT チュウケイ コネクタ		
J 156	NPN		1	POWER SUPPLY FAN, 1 電源ファン (1)	FM11	
	VS1 - 6321 - 003		1	CONNECTOR, 3P, FEMALE コネクタ (メス)	FM12	
J 157	NPN		1	POWER SUPPLY FAN, 2 電源ファン (2)		
	VS1 - 6321 - 003		1	CONNECTOR, 3P, FEMALE コネクタ (メス)		
J 158	VS1 - 6313 - 013		2	CONNECTOR, 13P, FEMALE コネクタ (メス)	PS57	
	VS1 - 6314 - 013		2	CONNECTOR, 13P, FEMALE コネクタ (メス)		
	VS1 - 6319 - 026		1	CONNECTOR, SNAP TIGHT チュウケイ コネクタ		
	VT2 - 5161 - 026		2	HOLDER, CONNECTOR, 26P コネクタ ホルダ		
J 159	NPN		GLASS SENSOR ガラス有無センサ			

FIGURE & KEY NO.	PART NUMBER	R A N K	Q' T Y	DESCRIPTION	SERIAL NUMBER / REMARKS
B - J 159	VS1 - 6321 - 003		1	CONNECTOR, 3P, FEMALE コネクタ (メス)	
J 162	FH2 - 6452 - 000		1	CABLE, FLUORESCENT LAMP 蛍光灯フレキ束線	
	FH2 - 6574 - 000		1	CABLE, FLUORESCENT 蛍光灯束線	
J 163	FH2 - 6452 - 000		1	CABLE, FLUORESCENT LAMP 蛍光灯フレキ束線	
	FH2 - 6453 - 000		1	CABLE, FLUORESCENT LAMP 蛍光灯束線	
J 164	FH2 - 6453 - 000		1	CABLE, FLUORESCENT LAMP 蛍光灯束線	
	VS1 - 6304 - 003		1	CONNECTOR, 3P, MALE コネクタ (オス)	
	WS3 - 5571 - 000		3	PIN CONTACT, 22-28AWG ピン コンタクト	
J 165	PCB			EXPOSURE SENSOR 調光センサ	
	VS1 - 6302 - 005		1	CONNECTOR, 5P, FEMALE コネクタ (メス)	
J 166	WS3 - 5569 - 000		3	SOCKET CONTACT, 22-28AWG ソケット コンタクト	H5
	NPN			FLUORESCENT LAMP HEATER 蛍光灯ヒータ	
	FH2 - 6453 - 000		1	CABLE, FLUORESCENT LAMP 蛍光灯束線	
J 167	VS1 - 6313 - 010		2	CONNECTOR, 10P, FEMALE コネクタ (メス)	
	VS1 - 6314 - 010		2	CONNECTOR, 10P, FEMALE コネクタ (メス)	
J 168	VS1 - 6319 - 020		1	CONNECTOR, SNAP TIGHT チュウケイ コネクタ	
	VT2 - 5161 - 020		2	HOLDER, CONNECTOR, 20P コネクタ ホルダ	
	VS1 - 5057 - 006		1	CONNECTOR, SNAP TIGHT チュウケイ コネクタ	
	VS1 - 6321 - 006		2	CONNECTOR, 6P, FEMALE コネクタ (メス)	
J 169	NPN			SCANNER HOME POSITION SENSOR 光学ホーム ポジション センサ	PS1
J 170	VS1 - 6321 - 003		1	CONNECTOR, 3P, FEMALE コネクタ (メス)	PS3
	NPN			DOCUMENT TOP SENSOR 画先センサ	
	VS1 - 6320 - 003		1	CONNECTOR, 3P, FEMALE コネクタ (メス)	
J 171	NPN			INVERTER FAN インバータ ファン	FM9
	VS1 - 6321 - 003		1	CONNECTOR, 3P, FEMALE コネクタ (メス)	
J 172	VS1 - 5057 - 007		1	CONNECTOR, SNAP TIGHT チュウケイ コネクタ	
	VS1 - 6321 - 007		2	CONNECTOR, 7P, FEMALE コネクタ (メス)	
J 173	VS1 - 6314 - 007		2	CONNECTOR, 7P, FEMALE コネクタ (メス)	
	VS1 - 6318 - 007		1	CONNECTOR, SNAP TIGHT チュウケイ コネクタ	
J 174	NPN			COPYBOARD COVER OPEN SENSOR 圧板開閉検知	PS4

FIGURE & KEY NO.	PART NUMBER	RANK	QTY	DESCRIPTION	SERIAL NUMBER / REMARKS
B - J 174	VS1 - 6321 - 003		1	CONNECTOR, 3P, FEMALE コネクタ (メス)	
J 175	VS1 - 5057 - 003		1	CONNECTOR, SNAP TIGHT チュウケイ コネクタ	
	VS1 - 6321 - 003		2	CONNECTOR, 3P, FEMALE コネクタ (メス)	
J 177	VS1 - 6314 - 003		2	CONNECTOR, 3P, FEMALE コネクタ (メス)	
	VS1 - 6318 - 003		1	CONNECTOR, SNAP TIGHT チュウケイ コネクタ	
J 180	VS1 - 6313 - 020		2	CONNECTOR, 20P, FEMALE コネクタ (メス)	
	VS1 - 6314 - 020		2	CONNECTOR, 20P, FEMALE コネクタ (メス)	
	VS1 - 6327 - 040		1	CONNECTOR, 40P, FEMALE コネクタ (メス)	
	VS1 - 6328 - 040		1	CONNECTOR, 40P, FEMALE コネクタ (メス)	
	VT2 - 5161 - 040		2	HOLDER, CONNECTOR, 40P コネクタ ホルダ	
	WS3 - 5607 - 000		2	SOCKET CONTACT, 20-24AWG コンタクト	
	WS3 - 5609 - 000		2	SOCKET CONTACT, 12-14AWG ソケット コンタクト	
J 182	NPN			INTERNAL DELIVERY SENSOR 内排紙センサ	PS9
	VS1 - 6321 - 003		1	CONNECTOR, 3P, FEMALE コネクタ (メス)	
J 184	NPN			EXTERNAL DELIVERY SENSOR 外排紙センサ	PS10
J 185	VS1 - 6321 - 003		1	CONNECTOR, 3P, FEMALE コネクタ (メス)	PS11
	NPN			FIXING EXIT SENSOR 定着出口センサ	
	VS1 - 6321 - 003		1	CONNECTOR, 3P, FEMALE コネクタ (メス)	
J 186	NPN			DELIVERY SPEED CHANGE CLUTCH 排紙速度切換クラッチ	CL21
	VS1 - 5057 - 002		1	CONNECTOR, SNAP TIGHT チュウケイ コネクタ	
J 187	VS1 - 6321 - 002		1	CONNECTOR, 2P, FEMALE コネクタ (メス)	
	VS1 - 6314 - 010		2	CONNECTOR, 10P, FEMALE コネクタ (メス)	
	VS1 - 6318 - 010		1	CONNECTOR, SNAP TIGHT チュウケイ コネクタ	
J 188	NPN			CLEANING BELT SENSOR ウェブ センサ	PS7
	VS1 - 6320 - 003		1	CONNECTOR, 3P, FEMALE コネクタ (メス)	
J 189	NPN			CLEANING BELT WARNING SENSOR ウェブ予告センサ	PS8
	VS1 - 6320 - 003		1	CONNECTOR, 3P, FEMALE コネクタ (メス)	
J 190	NPN			FIXING MAIN THERMISTOR 定着サーミスタ (メイン)	TH1
	VS1 - 5057 - 002		1	CONNECTOR, SNAP TIGHT チュウケイ コネクタ	
	VS1 - 6321 - 002		1	CONNECTOR, 2P, FEMALE コネクタ (メス)	

FIGURE & KEY NO.	PART NUMBER	RANK	QTY	DESCRIPTION	SERIAL NUMBER / REMARKS
B - J 191	NPN			FIXING SUB THERMISTOR 定着サーミスタ (サブ)	TH2
	VS1 - 5057 - 003		1	CONNECTOR, SNAP TIGHT チュウケイ コネクタ	
	VS1 - 6321 - 003		1	CONNECTOR, 3P, FEMALE コネクタ (メス)	
	J 192	VS1 - 6314 - 006	2	CONNECTOR, 6P, FEMALE コネクタ (メス)	
	VS1 - 6318 - 006	1	CONNECTOR, SNAP TIGHT チュウケイ コネクタ		
J 194	NPN		CLAW JAM SENSOR 爪ジャム センサ	PS6	
	VS1 - 6321 - 003		1	CONNECTOR, 3P, FEMALE コネクタ (メス)	
J 195	NPN		FLAPPER SOLENOID フラッパー ソレノイド	SL3	
	VS1 - 6321 - 002		1	CONNECTOR, 2P, FEMALE コネクタ (メス)	
J 196	NPN		CLEANING BELT SOLENOID ウェブ ソレノイド	SL2	
	VS1 - 5057 - 002		1	CONNECTOR, SNAP TIGHT チュウケイ コネクタ	
	VS1 - 6321 - 002		1	CONNECTOR, 2P, FEMALE コネクタ (メス)	
J 197	VS1 - 6313 - 013		2	CONNECTOR, 13P, FEMALE コネクタ (メス)	
	VS1 - 6314 - 013		2	CONNECTOR, 13P, FEMALE コネクタ (メス)	
	VS1 - 6327 - 026		1	CONNECTOR, 26P, FEMALE コネクタ (メス)	
	VS1 - 6328 - 026		1	CONNECTOR, 26P, FEMALE コネクタ (メス)	
	VT2 - 5161 - 026		2	HOLDER, CONNECTOR, 26P コネクタ ホルダ	
	WS3 - 5607 - 000		4	SOCKET CONTACT, 20-24AWG コンタクト	
	WS3 - 5609 - 000		4	SOCKET CONTACT, 12-14AWG ソケット コンタクト	
J 198	VS1 - 5057 - 007		1	CONNECTOR, SNAP TIGHT チュウケイ コネクタ	
J 199	VS1 - 6321 - 007		2	CONNECTOR, 7P, FEMALE コネクタ (メス)	PS5
	NPN			REGISTRATION SENSOR レジスト センサ	
	VS1 - 6321 - 003		1	CONNECTOR, 3P, FEMALE コネクタ (メス)	
J 200	NPN			REGISTRATION CLUTCH レジスト クラッチ	CL2
	VS1 - 5057 - 002		1	CONNECTOR, SNAP TIGHT チュウケイ コネクタ	
J 204	VS1 - 6321 - 002		1	CONNECTOR, 2P, FEMALE コネクタ (メス)	
	VS1 - 5057 - 004		1	CONNECTOR, SNAP TIGHT チュウケイ コネクタ	
	VS1 - 6321 - 004		2	CONNECTOR, 4P, FEMALE コネクタ (メス)	
J 205	NPN			UNIT LOCK SOLENOID ユニット ロック ソレノイド	SL4
	VS1 - 5057 - 003		1	CONNECTOR, SNAP TIGHT チュウケイ コネクタ	

FIGURE & KEY NO.	PART NUMBER	RANK	QTY	DESCRIPTION	SERIAL NUMBER / REMARKS
B - J 205	VS1 - 6321 - 003		1	CONNECTOR, 3P, FEMALE コネクタ (メス)	M9
J 206	NPN			TRANSFER/SEP. CLEANING MOTOR 転写 / 分離清掃モータ	
J 207	VS1 - 6321 - 002		1	CONNECTOR, 2P, FEMALE コネクタ (メス)	CL3
	NPN			REGISTRATION BRAKE CLUTCH レジスト ブレーキ クラッチ	
	VS1 - 5057 - 002		1	CONNECTOR, SNAP TIGHT チュウケイ コネクタ	
J 208	VS1 - 6321 - 002		1	CONNECTOR, 2P, FEMALE コネクタ (メス)	PS28
	NPN			FIXING/FEEDER LEVER SENSOR 定着 / 搬送レバー センサ	
J 209	VS1 - 6321 - 003		1	CONNECTOR, 3P, FEMALE コネクタ (メス)	FM6
	NPN			CURL FAN カール取りファン	
	VS1 - 5057 - 003		1	CONNECTOR, SNAP TIGHT チュウケイ コネクタ	
J 210	VS1 - 6321 - 003		1	CONNECTOR, 3P, FEMALE コネクタ (メス)	
	VS1 - 5057 - 003		1	CONNECTOR, SNAP TIGHT チュウケイ コネクタ	
J 211	VS1 - 6321 - 003		2	CONNECTOR, 3P, FEMALE コネクタ (メス)	
	VS1 - 5057 - 006		1	CONNECTOR, SNAP TIGHT チュウケイ コネクタ	
	VS1 - 6320 - 006		1	CONNECTOR, 6P, FEMALE コネクタ (メス)	
J 213	VS1 - 6321 - 006		1	CONNECTOR, 6P, FEMALE コネクタ (メス)	
	VS1 - 5057 - 006		1	CONNECTOR, SNAP TIGHT チュウケイ コネクタ	
J 214	VS1 - 6321 - 006		2	CONNECTOR, 6P, FEMALE コネクタ (メス)	
	VS1 - 5057 - 006		1	CONNECTOR, SNAP TIGHT チュウケイ コネクタ	
	VS1 - 6321 - 006		2	CONNECTOR, 6P, FEMALE コネクタ (メス)	
J 216	VS1 - 6314 - 002		2	CONNECTOR, 2P, FEMALE コネクタ (メス)	
	VS1 - 6318 - 002		1	CONNECTOR, SNAP TIGHT 中継コネクタ	
J 217	NPN			DEVELOPEMENT 2 CLUTCH 現像 (2) クラッチ	CL20
	VS1 - 5057 - 002		1	CONNECTOR, SNAP TIGHT チュウケイ コネクタ	
	VS1 - 6321 - 002		1	CONNECTOR, 2P, FEMALE コネクタ (メス)	
J 222	VS1 - 5057 - 003		1	CONNECTOR, SNAP TIGHT チュウケイ コネクタ	PS35
	VS1 - 6321 - 003		2	CONNECTOR, 3P, FEMALE コネクタ (メス)	
J 223	NPN			MULTI CURL INLET SENSOR マルチ カール付け入口センサ	
	VS1 - 6321 - 003		1	CONNECTOR, 3P, FEMALE コネクタ (メス)	
J 224	VS1 - 5057 - 012		1	CONNECTOR, SNAP TIGHT チュウケイ コネクタ	

FIGURE & KEY NO.	PART NUMBER	RANK	QTY	DESCRIPTION	SERIAL NUMBER / REMARKS
B - J 224	VS1 - 6321 - 012		2	CONNECTOR, 12P, FEMALE コネクタ (メス)	
J 225	NPN			MULTI PAPER WIDTH SENSOR マルチ紙幅検知	SVR1
	VS1 - 5057 - 003		1	CONNECTOR, SNAP TIGHT チュウケイ コネクタ	
	VS1 - 6321 - 003		1	CONNECTOR, 3P, FEMALE コネクタ (メス)	
J 226	NPN			MULTI PAPER SENSOR マルチ紙検知	PS17
	VS1 - 6321 - 003		1	CONNECTOR, 3P, FEMALE コネクタ (メス)	
J 227	NPN			MULTI PICK-UP SOLENOID マルチ給紙ソレノイド	SL6
	VS1 - 5057 - 003		1	CONNECTOR, SNAP TIGHT チュウケイ コネクタ	
	VS1 - 6321 - 003		1	CONNECTOR, 3P, FEMALE コネクタ (メス)	
J 228	SYS			TO 3.5K SIDE PAPER DECK 3.5Kサイド ペーパー デッキ	ACCESSORY
	FH2 - 6480 - 000		1	CONNECTOR, FEMALE コネクタ (メス)	
	VS1 - 5452 - 008		1	CONNECTOR, 8P, FEMALE コネクタ (メス)	
	WS3 - 5596 - 000		4	PIN CONTACT, 18-24AWG ピン コンタクト	
J 229	VS1 - 6313 - 014		2	CONNECTOR, 14P, FEMALE コネクタ (メス)	
	VS1 - 6314 - 014		2	CONNECTOR, 14P, FEMALE コネクタ (メス)	
	VS1 - 6319 - 028		1	CONNECTOR, SNAP TIGHT チュウケイ コネクタ	
J 230	VT2 - 5161 - 028		2	HOLDER, CONNECTOR, 28P コネクタ ホルダ	
	VS1 - 5057 - 002		1	CONNECTOR, SNAP TIGHT チュウケイ コネクタ	
	VS1 - 6320 - 002		1	CONNECTOR, 2P, FEMALE コネクタ (メス)	
	VS1 - 6321 - 002		1	CONNECTOR, 2P, FEMALE コネクタ (メス)	
J 231	NPN			VERTICAL PATH 1 CLUTCH 縦パス(1)クラッチ	CL8
	VS1 - 5057 - 002		1	CONNECTOR, SNAP TIGHT チュウケイ コネクタ	
	VS1 - 6321 - 002		1	CONNECTOR, 2P, FEMALE コネクタ (メス)	
J 232	NPN			RIGHT DECK LIFTER SENSOR 右デッキ リフタ センサ	PS21
	VS1 - 6321 - 003		1	CONNECTOR, 3P, FEMALE コネクタ (メス)	
J 233	NPN			RIGHT DECK PAPER SENSOR 右デッキ紙検知センサ	PS22
	VS1 - 6321 - 003		1	CONNECTOR, 3P, FEMALE コネクタ (メス)	
J 234	NPN			RIGHT PICK-UP SOLENOID 右デッキ給紙ソレノイド	SL7
	VS1 - 5057 - 002		1	CONNECTOR, SNAP TIGHT チュウケイ コネクタ	
	VS1 - 6321 - 002		1	CONNECTOR, 2P, FEMALE コネクタ (メス)	

FIGURE & KEY NO.	PART NUMBER	RANK	QTY	DESCRIPTION	SERIAL NUMBER / REMARKS
B - J 235	VS1 - 5057 - 008		1	CONNECTOR, SNAP TIGHT チュウケイ コネクタ	
	VS1 - 6321 - 008		2	CONNECTOR, 8P, FEMALE コネクタ (メス)	
J 236	NPN			RIGHT DECK OPEN/CLOSE SENSOR 右デッキ開閉センサ	PS23
	VS1 - 6321 - 003		1	CONNECTOR, 3P, FEMALE コネクタ (メス)	
J 237	NPN			RIGHT DECK LIMIT SENSOR 右デッキ リミット センサ	PS24
J 239	VS1 - 6321 - 003		1	CONNECTOR, 3P, FEMALE コネクタ (メス)	ACCESSORY
	VS1 - 5057 - 007		1	CONNECTOR, SNAP TIGHT チュウケイ コネクタ	
	VS1 - 6321 - 007		2	CONNECTOR, 7P, FEMALE コネクタ (メス)	
	SYS			TO ADF ADF	
J 240	VS1 - 5452 - 007		1	CONNECTOR, 7P, FEMALE コネクタ (メス)	
J 241	WS3 - 5596 - 000		3	PIN CONTACT, 18-24AWG ピン コンタクト	FM8
	NPN			DRUM INTAKE FAN ドラム吸引ファン	
	VS1 - 5057 - 003		1	CONNECTOR, SNAP TIGHT チュウケイ コネクタ	
J 242	VS1 - 6321 - 003		1	CONNECTOR, 3P, FEMALE コネクタ (メス)	CL4
	NPN			DEVELOPING SLEEVE CLUTCH 現像スリーブ クラッチ	
J 243	VS1 - 5057 - 002		1	CONNECTOR, SNAP TIGHT チュウケイ コネクタ	
	VS1 - 6321 - 002		1	CONNECTOR, 2P, FEMALE コネクタ (メス)	
	VS1 - 5057 - 007		1	CONNECTOR, SNAP TIGHT チュウケイ コネクタ	
	VS1 - 5824 - 007		1	CONNECTOR, 7P, FEMALE コネクタ (メス)	
	VS1 - 6321 - 007		1	CONNECTOR, 7P, FEMALE コネクタ (メス)	
J 244	WS3 - 5358 - 000		7	SOCKET CONTACT, 22-26AWG ソケット コンタクト	PS59
	NPN			CARTRIDGE DOOR SENSOR カートリッジ扉センサ	
	VS1 - 5824 - 003		1	CONNECTOR, 3P, FEMALE コネクタ (メス)	
J 245	WS3 - 5358 - 000		3	SOCKET CONTACT, 22-26AWG ソケット コンタクト	
	VS1 - 5057 - 002		1	CONNECTOR, SNAP TIGHT チュウケイ コネクタ	
J 246	VS1 - 5824 - 002		2	CONNECTOR, 2P, FEMALE コネクタ (メス)	MSW8
	WS3 - 5358 - 000		4	SOCKET CONTACT, 22-26AWG ソケット コンタクト	
	NPN			CARTRIDGE MOTOR DRIVE SWITCH カートリッジ モータ駆動スイッチ	
	RH2 - 5283 - 000		1	CONNECTOR, 3P, FEMALE コネクタ (メス)	
	WS3 - 5419 - 000		2	SOCKET CONTACT, 22-26AWG ソケット コンタクト	

FIGURE & KEY NO.	PART NUMBER	RANK	QTY	DESCRIPTION	SERIAL NUMBER / REMARKS
B - J 247	NPN			CARTRIDGE MOTOR カートリッジ モータ	M6
	VS1 - 6373 - 002		1	CONNECTOR, 2P, FEMALE コネクタ (メス)	
J 248	WS3 - 5569 - 000		2	SOCKET CONTACT, 22-28AWG ソケット コンタクト	MSW1
	NPN			CARTRIDGE DETECT SWITCH カートリッジ有無スイッチ	
	VS1 - 6302 - 002		1	CONNECTOR, 2P, FEMALE コネクタ (メス)	
J 249	WS3 - 5569 - 000		2	SOCKET CONTACT, 22-28AWG ソケット コンタクト	
	VS1 - 5057 - 007		1	CONNECTOR, SNAP TIGHT チュウケイ コネクタ	
J 250	VS1 - 6321 - 007		2	CONNECTOR, 7P, FEMALE コネクタ (メス)	
	VS1 - 5057 - 007		1	CONNECTOR, SNAP TIGHT チュウケイ コネクタ	
	VS1 - 6321 - 007		2	CONNECTOR, 7P, FEMALE コネクタ (メス)	
J 251	NPN			WASTE TONER CLOGGING SWITCH 廃トナー詰まりスイッチ	MSW2
	VS1 - 5057 - 002		1	CONNECTOR, SNAP TIGHT チュウケイ コネクタ	
J 252	VS1 - 6321 - 002		1	CONNECTOR, 2P, FEMALE コネクタ (メス)	
	VS1 - 5057 - 002		1	CONNECTOR, SNAP TIGHT チュウケイ コネクタ	
	VS1 - 6321 - 002		2	CONNECTOR, 2P, FEMALE コネクタ (メス)	
J 253	VS1 - 5057 - 002		1	CONNECTOR, SNAP TIGHT チュウケイ コネクタ	
	VS1 - 6321 - 002		2	CONNECTOR, 2P, FEMALE コネクタ (メス)	
J 254	VS1 - 5057 - 002		1	CONNECTOR, SNAP TIGHT チュウケイ コネクタ	
	VS1 - 6321 - 002		2	CONNECTOR, 2P, FEMALE コネクタ (メス)	
J 255	NPN			FRONT REGISTRATION CLUTCH レジ前クラッチ	CL5
J 256	VS1 - 5057 - 002		1	CONNECTOR, SNAP TIGHT チュウケイ コネクタ	SVR2
	VS1 - 6321 - 002		1	CONNECTOR, 2P, FEMALE コネクタ (メス)	
	NPN			CASSETTE 3 PAPER WIDTH SENSOR カセット (3) 紙幅検知	
	VS1 - 5057 - 003		1	CONNECTOR, SNAP TIGHT チュウケイ コネクタ	
	VS1 - 6321 - 003		1	CONNECTOR, 3P, FEMALE コネクタ (メス)	
J 257	NPN			CASSETTE 3 PAPER LENGTH SENSOR カセット (3) 長さ検知	SV1
	VS1 - 5057 - 004		1	CONNECTOR, SNAP TIGHT チュウケイ コネクタ	
J 258	VS1 - 6321 - 004		1	CONNECTOR, 4P, FEMALE コネクタ (メス)	
	VS1 - 5057 - 006		1	CONNECTOR, SNAP TIGHT チュウケイ コネクタ	
	VS1 - 6321 - 006		2	CONNECTOR, 6P, FEMALE コネクタ (メス)	

FIGURE & KEY NO.	PART NUMBER	RANK	QTY	DESCRIPTION	SERIAL NUMBER / REMARKS
B - J 259	NPN			RIGHT DECK PAPER MIDDLE SENSOR 右デッキ紙残量センサ(中)	PS51
	VS1 - 6321 - 003		1	CONNECTOR, 3P, FEMALE コネクタ (メス)	
	J 260	NPN		RIGHT DECK PAPER UPPER SENSOR 右デッキ紙残量センサ(上)	
VS1 - 6321 - 003		1	CONNECTOR, 3P, FEMALE コネクタ (メス)		
J 261	VS1 - 5057 - 003		1	CONNECTOR, SNAP TIGHT チュウケイ コネクタ	
J 262	VS1 - 6321 - 003		2	CONNECTOR, 3P, FEMALE コネクタ (メス)	PS19
	NPN			WASTE TONER FULL SENSOR 廃トナー満杯検知	
	VS1 - 6321 - 003		1	CONNECTOR, 3P, FEMALE コネクタ (メス)	
J 263	NPN			RIGHT DECK LIFTER MOTOR 右デッキ リフタ モータ	M13
	VS1 - 6321 - 002		1	CONNECTOR, 2P, FEMALE コネクタ (メス)	
J 264	VS1 - 5057 - 002		1	CONNECTOR, SNAP TIGHT チュウケイ コネクタ	SVR3
	VS1 - 6321 - 002		2	CONNECTOR, 2P, FEMALE コネクタ (メス)	
J 265	NPN			CASSETTE 4 PAPER WIDTH SENSOR カセット(4)紙幅検知	
	VS1 - 5057 - 003		1	CONNECTOR, SNAP TIGHT チュウケイ コネクタ	
	VS1 - 6321 - 003		1	CONNECTOR, 3P, FEMALE コネクタ (メス)	
J 266	NPN			CASSETTE 4 PAPER LENGTH SENSOR カセット(4)長さ検知	SV2
	VS1 - 5057 - 004		1	CONNECTOR, SNAP TIGHT チュウケイ コネクタ	
	VS1 - 6321 - 004		1	CONNECTOR, 4P, FEMALE コネクタ (メス)	
J 267	NPN			LEFT DECK LIFTER MOTOR 左デッキ リフタ モータ	M14
	VS1 - 6321 - 002		1	CONNECTOR, 2P, FEMALE コネクタ (メス)	
J 268	VS1 - 5057 - 006		1	CONNECTOR, SNAP TIGHT チュウケイ コネクタ	PS54
	VS1 - 6321 - 006		2	CONNECTOR, 6P, FEMALE コネクタ (メス)	
J 269	NPN			LEFT DECK PAPER MIDDLE SENSOR 左デッキ紙残量検センサ(中)	
	VS1 - 6321 - 003		1	CONNECTOR, 3P, FEMALE コネクタ (メス)	
J 270	NPN			LEFT DECK PAPER UPPER SENSOR 左デッキ紙残量センサ(上)	PS55
J 271	VS1 - 6321 - 003		1	CONNECTOR, 3P, FEMALE コネクタ (メス)	CL6
	NPN			FRONT REGIST. BRAKE CLUTCH レジ前ブレーキ クラッチ	
	VS1 - 6321 - 002		1	CONNECTOR, 2P, FEMALE コネクタ (メス)	
	VS1 - 5057 - 002		1	CONNECTOR, SNAP TIGHT チュウケイ コネクタ	
	FG6 - 3569 - 000		1	CABLE, BIAS SEPARATION CLAW 分離爪バイアス束線	

FIGURE & KEY NO.	PART NUMBER	R A N K	Q' T Y	DESCRIPTION	SERIAL NUMBER / REMARKS	
B - J 271	VS1 - 5729 - 002		1	CONNECTOR, 2P, MALE コネクタ (オス)	PS27	
	WS3 - 5301 - 000		1	PIN CONTACT ピン コントクト		
J 272	FG6 - 3568 - 000		1	CABLE, SEPARATION CLAW 分離爪束線		
	FG6 - 3569 - 000		1	CABLE, BIAS SEPARATION CLAW 分離爪バイアス束線		
J 276	NPN		RIGHT DECK PULL-OUT SENSOR 右デッキ引き抜きセンサ			
J 278	VS1 - 6314 - 004		1	CONNECTOR, 4P, FEMALE コネクタ (メス)		PS20
	NPN			RIGHT DECK PICK-UP SENSOR 右デッキ給紙センサ		
J 280	VS1 - 6314 - 004		1	CONNECTOR, 4P, FEMALE コネクタ (メス)		PS37
	NPN			CASSETTE 3 PICK-UP SENSOR カセット (3) 給紙センサ		
	VS1 - 6314 - 004		1	CONNECTOR, 4P, FEMALE コネクタ (メス)		
J 281	VS1 - 6313 - 013		2	CONNECTOR, 13P, FEMALE コネクタ (メス)		
	VS1 - 6314 - 013		2	CONNECTOR, 13P, FEMALE コネクタ (メス)		
	VS1 - 6319 - 026		1	CONNECTOR, SNAP TIGHT チュウケイ コネクタ		
	VT2 - 5161 - 026		2	HOLDER, CONNECTOR, 26P コネクタ ホルダ		
J 282	VS1 - 5057 - 002		1	CONNECTOR, SNAP TIGHT チュウケイ コネクタ		
J 283	VS1 - 6321 - 002		2	CONNECTOR, 2P, FEMALE コネクタ (メス)		CL13
	NPN			CASSETTE 3 VERT. PATH CLUTCH カセット (3) 縦パス クラッチ		
	VS1 - 5057 - 002		1	CONNECTOR, SNAP TIGHT チュウケイ コネクタ		
J 284	VS1 - 6320 - 002		1	CONNECTOR, 2P, FEMALE コネクタ (メス)		PS38
	NPN			CASSETTE 3 LIFTER SENSOR カセット (3) リフタ センサ		
J 285	VS1 - 6321 - 003		1	CONNECTOR, 3P, FEMALE コネクタ (メス)	PS39	
	NPN			CASSETTE 3 PAPER DETECT SENSOR カセット (3) 紙検センサ		
J 286	VS1 - 6321 - 003		1	CONNECTOR, 3P, FEMALE コネクタ (メス)		
	VS1 - 5057 - 008		1	CONNECTOR, SNAP TIGHT チュウケイ コネクタ		
	VS1 - 6321 - 008		2	CONNECTOR, 8P, FEMALE コネクタ (メス)		
J 287	NPN			CASSETTE 3 OPEN/CLOSE SENSOR カセット (3) 開閉センサ	PS40	
J 289	VS1 - 6320 - 003		1	CONNECTOR, 3P, FEMALE コネクタ (メス)	SL9	
	NPN			CASSETTE 3 PICK-UP SOLENOID カセット (3) 給紙ソレノイド		
	VS1 - 5057 - 002		1	CONNECTOR, SNAP TIGHT チュウケイ コネクタ		
	VS1 - 6321 - 002		1	CONNECTOR, 2P, FEMALE コネクタ (メス)		

FIGURE & KEY NO.	PART NUMBER	RANK	QTY	DESCRIPTION	SERIAL NUMBER / REMARKS
B - J 290	VS1 - 6313 - 011		2	CONNECTOR, 11P, FEMALE コネクタ (メス)	
	VS1 - 6314 - 011		2	CONNECTOR, 11P, FEMALE コネクタ (メス)	
	VS1 - 6319 - 022		1	CONNECTOR, SNAP TIGHT チュウケイ コネクタ	
	VT2 - 5161 - 022		2	HOLDER, CONNECTOR, 22P コネクタ ホルダ	
J 291	VS1 - 5057 - 004		1	CONNECTOR, SNAP TIGHT チュウケイ コネクタ	
J 292	VS1 - 6321 - 004		2	CONNECTOR, 4P, FEMALE コネクタ (メス)	PS48
	NPN			RIGHT DOOR LOWER OPEN SENSOR 右扉下開閉センサ	
J 293	VS1 - 6321 - 003		1	CONNECTOR, 3P, FEMALE コネクタ (メス)	M16
	NPN			CASSETTE 3 LIFTER MOTOR カセット(3) リフタ モータ	
J 294	VS1 - 6321 - 002		1	CONNECTOR, 2P, FEMALE コネクタ (メス)	
	VS1 - 5057 - 003		1	CONNECTOR, SNAP TIGHT チュウケイ コネクタ	
J 295	VS1 - 6321 - 003		2	CONNECTOR, 3P, FEMALE コネクタ (メス)	
	PCB			CASSETTE 3 PAPER DETECT カセット(3) 紙残量検知	
J 296	VS1 - 6321 - 003		1	CONNECTOR, 3P, FEMALE コネクタ (メス)	PS41
	NPN			CASSETTE 3 VERT. PATH SENSOR カセット(3) 縦パス センサ	
J 298	VS1 - 6314 - 004		1	CONNECTOR, 4P, FEMALE コネクタ (メス)	M17
	NPN			CASSETTE 4 LIFTER MOTOR カセット(4) リフタ モータ	
J 302	VS1 - 5057 - 002		1	CONNECTOR, SNAP TIGHT チュウケイ コネクタ	
	VS1 - 6321 - 002		1	CONNECTOR, 2P, FEMALE コネクタ (メス)	
J 303	PCB			HUMIDITY SENSOR 湿度センサ	
	VS1 - 6321 - 005		1	CONNECTOR, 5P, FEMALE コネクタ (メス)	
J 304	VS1 - 6321 - 003		2	CONNECTOR, 3P, FEMALE コネクタ (メス)	PS49
	NPN			VERTICAL PATH 2 SENSOR 縦パス(2) センサ	
	VS1 - 6321 - 003		1	CONNECTOR, 3P, FEMALE コネクタ (メス)	
	VS1 - 6313 - 013		2	CONNECTOR, 13P, FEMALE コネクタ (メス)	
J 305	VS1 - 6314 - 013		2	CONNECTOR, 13P, FEMALE コネクタ (メス)	

FIGURE & KEY NO.	PART NUMBER	RANK	QTY	DESCRIPTION	SERIAL NUMBER / REMARKS	
B - J 305	VS1 - 6319 - 026		1	CONNECTOR, SNAP TIGHT チュウケイ コネクタ	CL15	
	VT2 - 5161 - 026		2	HOLDER, CONNECTOR, 26P コネクタ ホルダ		
J 306	VS1 - 5057 - 002		1	CONNECTOR, SNAP TIGHT チュウケイ コネクタ		
	VS1 - 6321 - 002		2	CONNECTOR, 2P, FEMALE コネクタ (メス)		
J 307	NPN		CASSETTE 4 VERT. PATH CLUTCH カセット (4) 縦パス クラッチ			
J 308	VS1 - 5057 - 002		1	CONNECTOR, SNAP TIGHT チュウケイ コネクタ		PS43
	VS1 - 6320 - 002		1	CONNECTOR, 2P, FEMALE コネクタ (メス)		
	NPN			CASSETTE 4 LIFTER MOTOR カセット (4) リフト モータ		
J 309	NPN		VS1 - 6321 - 003 CONNECTOR, 3P, FEMALE コネクタ (メス)	PS44		
J 311	VS1 - 6321 - 003		1	CONNECTOR, 3P, FEMALE コネクタ (メス)		PS45
	NPN			CASSETTE 4 OPEN/CLOSE SENSOR カセット (4) 開閉センサ		
J 313	VS1 - 6320 - 003		1	CONNECTOR, 3P, FEMALE コネクタ (メス)	SL10	
	NPN			CASSETTE 4 PICK-UP SOLENOID カセット (4) 給紙ソレノイド		
	VS1 - 5057 - 002		1	CONNECTOR, SNAP TIGHT チュウケイ コネクタ		
J 314	VS1 - 6321 - 002		1	CONNECTOR, 2P, FEMALE コネクタ (メス)		
	VS1 - 6313 - 010		2	CONNECTOR, 10P, FEMALE コネクタ (メス)		
	VS1 - 6314 - 010		2	CONNECTOR, 10P, FEMALE コネクタ (メス)		
	VS1 - 6319 - 020		1	CONNECTOR, SNAP TIGHT チュウケイ コネクタ		
	VT2 - 5161 - 020		2	HOLDER, CONNECTOR, 20P コネクタ ホルダ		
J 315	NPN		LEFT DECK LIFTER SENSOR 左デッキ リフト センサ	PS31		
J 316	VS1 - 6321 - 003		1	CONNECTOR, 3P, FEMALE コネクタ (メス)	PS32	
	NPN			LEFT DECK PAPER SENSOR 左デッキ紙検センサ		
J 317	VS1 - 6321 - 003		1	CONNECTOR, 3P, FEMALE コネクタ (メス)		
J 317	VS1 - 5057 - 004		1	CONNECTOR, SNAP TIGHT チュウケイ コネクタ		
J 318	VS1 - 6321 - 004		2	CONNECTOR, 4P, FEMALE コネクタ (メス)	PS33	
	NPN			LEFT DECK OPEN/CLOSE SENSOR 左デッキ開閉センサ		
J 319	VS1 - 6321 - 003		1	CONNECTOR, 3P, FEMALE コネクタ (メス)	PS34	
	NPN			LEFT DECK LIMIT SENSOR 左デッキ リミット センサ		
	VS1 - 6321 - 003		1	CONNECTOR, 3P, FEMALE コネクタ (メス)		

FIGURE & KEY NO.	PART NUMBER	RANK	QTY	DESCRIPTION	SERIAL NUMBER / REMARKS
B - J 320	VS1 - 5057 - 002		1	CONNECTOR, SNAP TIGHT チュウケイ コネクタ	SL8
	VS1 - 6321 - 002		2	CONNECTOR, 2P, FEMALE コネクタ (メス)	
	J 321	NPN		LEFT DECK PICK-UP SOLENOID 左デッキ給紙ソレノイド	
	VS1 - 5057 - 002		1	CONNECTOR, SNAP TIGHT チュウケイ コネクタ	
	VS1 - 6321 - 002		1	CONNECTOR, 2P, FEMALE コネクタ (メス)	
J 322	FG6 - 8616 - 000		1	CABLE, THROUGH-PATH DRAWER スルーパス ドロア束線	
	VS1 - 6313 - 016		1	CONNECTOR, 16P, FEMALE コネクタ (メス)	
	VS1 - 6314 - 016		1	CONNECTOR, 16P, FEMALE コネクタ (メス)	
	VS1 - 6328 - 032		1	CONNECTOR, 32P, FEMALE コネクタ (メス)	
	VT2 - 5161 - 032		1	HOLDER, CONNECTOR, 32P コネクタ ホルダ	
J 323	WS3 - 5607 - 000		4	SOCKET CONTACT, 20-24AWG コンタクト	
	FG6 - 8616 - 000		1	CABLE, THROUGH-PATH DRAWER スルーパス ドロア束線	
	VS1 - 6702 - 012		1	CONNECTOR, 12P, FEMALE コネクタ (メス)	
	WS3 - 5720 - 000		12	SOCKET CONTACT, 22-28AWG ソケット コンタクト	
J 324	NPN		DUPLEXING FEED MOTOR 両面搬送モータ	M12	
J 325	VS1 - 6702 - 006		1	CONNECTOR, 6P, FEMALE コネクタ (メス)	M11
	WS3 - 5720 - 000		6	SOCKET CONTACT, 22-28AWG ソケット コンタクト	
	NPN			DUPLEXING INVERT MOTOR 両面反転モータ	
	VS1 - 6702 - 007		1	CONNECTOR, 7P, FEMALE コネクタ (メス)	
	WS3 - 5720 - 000		6	SOCKET CONTACT, 22-28AWG ソケット コンタクト	
J 326	FG6 - 8616 - 000		1	CABLE, THROUGH-PATH DRAWER スルーパス ドロア束線	
	VS1 - 6314 - 003		1	CONNECTOR, 3P, FEMALE コネクタ (メス)	
	VS1 - 6318 - 003		1	CONNECTOR, SNAP TIGHT チュウケイ コネクタ	
J 327	NPN		FRONT JOINT SENSOR 合流前センサ	PS14	
	VS1 - 6321 - 003		1	CONNECTOR, 3P, FEMALE コネクタ (メス)	
J 328	NPN			LEFT DECK PULL SENSOR 左デッキ引き抜きセンサ	PS26
	VS1 - 6314 - 004		1	CONNECTOR, 4P, FEMALE コネクタ (メス)	
J 329	NPN			SIDE REGISTRATION MOTOR 横レジ モータ	M15
	FG6 - 8616 - 000		1	CABLE, THROUGH-PATH DRAWER スルーパス ドロア束線	
J 330	FG6 - 8616 - 000		1	CABLE, THROUGH-PATH DRAWER スルーパス ドロア束線	

FIGURE & KEY NO.	PART NUMBER	RANK	QTY	DESCRIPTION	SERIAL NUMBER / REMARKS
B - J 330	VS1 - 5057 - 009		1	CONNECTOR, SNAP TIGHT チュウケイ コネクタ	CL17
	VS1 - 6321 - 009		1	CONNECTOR, 9P, FEMALE コネクタ (メス)	
	J 331 NPN			LOWER FEED RIGHT CLUTCH 下搬送右クラッチ	
	VS1 - 5057 - 002		1	CONNECTOR, SNAP TIGHT チュウケイ コネクタ	
	VS1 - 6321 - 002		1	CONNECTOR, 2P, FEMALE コネクタ (メス)	
J 332	NPN			LOWER FEED CENTER CLUTCH 下搬送中クラッチ	CL16
	VS1 - 5057 - 002		1	CONNECTOR, SNAP TIGHT チュウケイ コネクタ	
	VS1 - 6321 - 002		1	CONNECTOR, 2P, FEMALE コネクタ (メス)	
J 333	NPN			LEFT DECK PULL CLUTCH 左デッキ引き抜きクラッチ	CL19
	VS1 - 5057 - 002		1	CONNECTOR, SNAP TIGHT チュウケイ コネクタ	
J 334	VS1 - 6321 - 002		1	CONNECTOR, 2P, FEMALE コネクタ (メス)	
	VS1 - 5057 - 003		1	CONNECTOR, SNAP TIGHT チュウケイ コネクタ	
	VS1 - 5824 - 003		1	CONNECTOR, 3P, FEMALE コネクタ (メス)	
	VS1 - 6321 - 003		1	CONNECTOR, 3P, FEMALE コネクタ (メス)	
	WS3 - 5358 - 000		3	SOCKET CONTACT, 22-26AWG ソケット コンタクト	
J 335	NPN			SIDE REGISTRATION SENSOR 横レジ センサ	PS18
	VS1 - 0279 - 003		1	CONNECTOR, 3P, FEMALE コネクタ (メス)	
	WS3 - 0469 - 000		3	SOCKET CONTACT, 26-30AWG ソケット コンタクト	
J 336	FG6 - 8616 - 000		1	CABLE, THROUGH-PATH DRAWER スルーパス ドロア束線	
	VS1 - 5057 - 003		1	CONNECTOR, SNAP TIGHT チュウケイ コネクタ	
J 337	VS1 - 6321 - 003		1	CONNECTOR, 3P, FEMALE コネクタ (メス)	PS15
	NPN			AFTER JOINT SENSOR 合流後センサ	
J 338	VS1 - 6321 - 003		1	CONNECTOR, 3P, FEMALE コネクタ (メス)	
	FG6 - 8616 - 000		1	CABLE, THROUGH-PATH DRAWER スルーパス ドロア束線	
J 339	VS1 - 6321 - 003		1	CONNECTOR, 3P, FEMALE コネクタ (メス)	PS61
	NPN			DUPLEXING OUTLET SENSOR 両面出口センサ	
J 340	VS1 - 6321 - 003		1	CONNECTOR, 3P, FEMALE コネクタ (メス)	
	FG6 - 8616 - 000		1	CABLE, THROUGH-PATH DRAWER スルーパス ドロア束線	
	VS1 - 5057 - 003		1	CONNECTOR, SNAP TIGHT チュウケイ コネクタ	

FIGURE & KEY NO.	PART NUMBER	RANK	QTY	DESCRIPTION	SERIAL NUMBER / REMARKS
B - J 340	VS1 - 6321 - 003		2	CONNECTOR, 3P, FEMALE コネクタ (メス)	PS12
J 341	NPN			DUPLEXING INVERT SENSOR 両面反転センサ	
	VS1 - 6321 - 003		1	CONNECTOR, 3P, FEMALE コネクタ (メス)	
J 342	VS1 - 5057 - 003		1	CONNECTOR, SNAP TIGHT チュウケイ コネクタ	
	VS1 - 6321 - 003		2	CONNECTOR, 3P, FEMALE コネクタ (メス)	
J 343	VS1 - 6314 - 004		2	CONNECTOR, 4P, FEMALE コネクタ (メス)	
	VS1 - 6318 - 004		1	CONNECTOR, SNAP TIGHT チュウケイ コネクタ	
J 344	SYS			FOR RS-232C RS - 232C用	
	VS1 - 6314 - 008		1	CONNECTOR, 8P, FEMALE コネクタ (メス)	
	VS1 - 6318 - 008		1	CONNECTOR, SNAP TIGHT チュウケイ コネクタ	
J 346	VS1 - 6314 - 003		2	CONNECTOR, 3P, FEMALE コネクタ (メス)	FM18
	VS1 - 6318 - 003		1	CONNECTOR, SNAP TIGHT チュウケイ コネクタ	
J 347	VS1 - 6314 - 003		2	CONNECTOR, 3P, FEMALE コネクタ (メス)	
	VS1 - 6318 - 003		1	CONNECTOR, SNAP TIGHT チュウケイ コネクタ	
J 348	NPN			SCANNER MOTOR COOLING FAN 光学モータ冷却ファン	
J 350	VS1 - 6321 - 004		1	CONNECTOR, 4P, FEMALE コネクタ (メス)	PS46
	VS1 - 5057 - 008		1	CONNECTOR, SNAP TIGHT チュウケイ コネクタ	
	VS1 - 6321 - 008		2	CONNECTOR, 8P, FEMALE コネクタ (メス)	
J 351	NPN			CASSETTE 4 VERT. PATH SENSOR カセット(4)縦パス センサ	
	VS1 - 6314 - 004		1	CONNECTOR, 4P, FEMALE コネクタ (メス)	
J 355	NPN			LEFT DECK PICK-UP SENSOR 左デッキ給紙センサ	PS25
	VS1 - 6314 - 004		1	CONNECTOR, 4P, FEMALE コネクタ (メス)	PS42
J 359	NPN			CASSETTE 4 PICK-UP SENSOR カセット(4)給紙センサ	
	VS1 - 6314 - 004		1	CONNECTOR, 4P, FEMALE コネクタ (メス)	
J 362	VS1 - 5057 - 002		1	CONNECTOR, SNAP TIGHT チュウケイ コネクタ	
J 363	VS1 - 6321 - 002		2	CONNECTOR, 2P, FEMALE コネクタ (メス)	
	VS1 - 5057 - 003		1	CONNECTOR, SNAP TIGHT チュウケイ コネクタ	
	VS1 - 6321 - 003		2	CONNECTOR, 3P, FEMALE コネクタ (メス)	
J 364	VS1 - 5057 - 003		1	CONNECTOR, SNAP TIGHT チュウケイ コネクタ	
	VS1 - 6321 - 003		2	CONNECTOR, 3P, FEMALE コネクタ (メス)	

FIGURE & KEY NO.	PART NUMBER	RANK	QTY	DESCRIPTION	SERIAL NUMBER / REMARKS	
B - J 365	VS1 - 5057 - 002		1	CONNECTOR, SNAP TIGHT チュウケイ コネクタ		
	VS1 - 6321 - 002		2	CONNECTOR, 2P, FEMALE コネクタ (メス)		
	J 366	FG6 - 8616 - 000		1	CABLE, THROUGH-PATH DRAWER スルーパス ドロア束線	
		VS1 - 6314 - 004		1	CONNECTOR, 4P, FEMALE コネクタ (メス)	
		VS1 - 6318 - 004		1	CONNECTOR, SNAP TIGHT チュウケイ コネクタ	
J 380	FG6 - 8616 - 000		1	CABLE, THROUGH-PATH DRAWER スルーパス ドロア束線		
	VS1 - 6702 - 006		1	CONNECTOR, 6P, FEMALE コネクタ (メス)		
	WS3 - 5720 - 000		6	SOCKET CONTACT, 22-28AWG ソケット コンタクト		
	J 381	FG6 - 8616 - 000		1	CABLE, THROUGH-PATH DRAWER スルーパス ドロア束線	
		VS1 - 5057 - 003		1	CONNECTOR, SNAP TIGHT チュウケイ コネクタ	
	J 382	VS1 - 6321 - 003		1	CONNECTOR, 3P, FEMALE コネクタ (メス)	M19
NPN				DUPLEXING FEED MOTOR 両面搬送モータ		
VS1 - 6702 - 006			1	CONNECTOR, 6P, FEMALE コネクタ (メス)		
WS3 - 5720 - 000			6	SOCKET CONTACT, 22-28AWG ソケット コンタクト		
J 383	NPN		DUPLEXING FEEDER FAN 両面搬送ファン	FM19		
J 401	VS1 - 5057 - 003		1	CONNECTOR, SNAP TIGHT チュウケイ コネクタ		
	VS1 - 6321 - 003		1	CONNECTOR, 3P, FEMALE コネクタ (メス)		
	VS1 - 6314 - 004		2	CONNECTOR, 4P, FEMALE コネクタ (メス)		
	VS1 - 6318 - 004		1	CONNECTOR, SNAP TIGHT チュウケイ コネクタ		
J 402	VS1 - 6314 - 009		2	CONNECTOR, 9P, FEMALE コネクタ (メス)		
J 403	VS1 - 6318 - 009		1	CONNECTOR, SNAP TIGHT チュウケイ コネクタ		
	SYS			FOR RS-232C RS - 232C用		
	VS1 - 6314 - 013		1	CONNECTOR, 13P, FEMALE コネクタ (メス)		
	VS1 - 6318 - 013		1	CONNECTOR, SNAP TIGHT チュウケイ コネクタ		
J 404	VS1 - 6314 - 011		2	CONNECTOR, 11P, FEMALE コネクタ (メス)		
J 405	VS1 - 6318 - 011		1	CONNECTOR, SNAP TIGHT チュウケイ コネクタ		
	VS1 - 6313 - 018		1	CONNECTOR, 18P, FEMALE コネクタ (メス)		
	VS1 - 6314 - 018		1	CONNECTOR, 18P, FEMALE コネクタ (メス)		
	VS1 - 6319 - 036		1	CONNECTOR, 36P, MALE コネクタ (オス)		
	VT2 - 5161 - 036		1	HOLDER, CONNECTOR, 36P コネクタ ホルダ		

FIGURE & KEY NO.	PART NUMBER	RANK	QTY	DESCRIPTION	SERIAL NUMBER / REMARKS
B - J 407	VS1 - 6313 - 017		1	CONNECTOR, 17P, FEMALE コネクタ (メス)	
	VS1 - 6314 - 017		1	CONNECTOR, 17P, FEMALE コネクタ (メス)	
	VS1 - 6319 - 034		1	CONNECTOR, 34P, MALE コネクタ (オス)	
	VT2 - 5161 - 034		1	HOLDER, CONNECTOR, 34P コネクタ ホルダ	
J 408	VS1 - 6314 - 005		2	CONNECTOR, 5P, FEMALE コネクタ (メス)	
J 409	VS1 - 6318 - 005		1	CONNECTOR, SNAP TIGHT チュウケイ コネクタ	ACCESSORY
	SYS			TO CARD READER カード リーダ	
J 501	VS1 - 6314 - 005		1	CONNECTOR, 5P, FEMALE コネクタ (メス)	
	PCB			DC CONTROLLER DCコントローラ	
	VS3 - 5083 - 007		1	CONNECTOR, 7P, FEMALE コネクタ (メス)	
J 502	WS3 - 5160 - 000		7	SOCKET CONTACT, 18-24AWG ソケット コンタクト	
	PCB			DC CONTROLLER DCコントローラ	
	VS1 - 6313 - 011		1	CONNECTOR, 11P, FEMALE コネクタ (メス)	
	VS1 - 6314 - 011		1	CONNECTOR, 11P, FEMALE コネクタ (メス)	
	VT2 - 5161 - 022		1	HOLDER, CONNECTOR, 22P コネクタ ホルダ	
J 503	PCB			DC CONTROLLER DCコントローラ	
	VS1 - 6313 - 010		1	CONNECTOR, 10P, FEMALE コネクタ (メス)	
	VS1 - 6314 - 010		1	CONNECTOR, 10P, FEMALE コネクタ (メス)	
	VT2 - 5161 - 020		1	HOLDER, CONNECTOR, 20P コネクタ ホルダ	
J 504	PCB			DC CONTROLLER DCコントローラ	
J 505	VS1 - 6313 - 014		1	CONNECTOR, 14P, FEMALE コネクタ (メス)	
	VS1 - 6314 - 014		1	CONNECTOR, 14P, FEMALE コネクタ (メス)	
	VT2 - 5161 - 028		1	HOLDER, CONNECTOR, 28P コネクタ ホルダ	
	PCB			DC CONTROLLER DCコントローラ	
	VS1 - 6313 - 016		1	CONNECTOR, 16P, FEMALE コネクタ (メス)	
J 506	VS1 - 6314 - 016		1	CONNECTOR, 16P, FEMALE コネクタ (メス)	
	VT2 - 5161 - 032		1	HOLDER, CONNECTOR, 32P コネクタ ホルダ	
	PCB			DC CONTROLLER DCコントローラ	
	VS1 - 6313 - 014		1	CONNECTOR, 14P, FEMALE コネクタ (メス)	
	VS1 - 6314 - 014		1	CONNECTOR, 14P, FEMALE コネクタ (メス)	

FIGURE & KEY NO.	PART NUMBER	R A N K	Q' T Y	DESCRIPTION	SERIAL NUMBER / REMARKS
B - J 506	VT2 - 5161 - 028		1	HOLDER, CONNECTOR, 28P コネクタ ホルダ	
J 507	PCB			DC CONTROLLER DCコントローラ	
	VS1 - 6313 - 008		1	CONNECTOR, 8P, FEMALE コネクタ (メス)	
	VS1 - 6314 - 008		1	CONNECTOR, 8P, FEMALE コネクタ (メス)	
	VT2 - 5161 - 016		1	HOLDER, CONNECTOR, 16P コネクタ ホルダ	
J 508	PCB			DC CONTROLLER DCコントローラ	
	VS1 - 6313 - 020		1	CONNECTOR, 20P, FEMALE コネクタ (メス)	
	VS1 - 6314 - 020		1	CONNECTOR, 20P, FEMALE コネクタ (メス)	
	VT2 - 5161 - 040		1	HOLDER, CONNECTOR, 40P コネクタ ホルダ	
J 509	PCB			DC CONTROLLER DCコントローラ	
	VS1 - 6313 - 013		1	CONNECTOR, 13P, FEMALE コネクタ (メス)	
	VS1 - 6314 - 013		1	CONNECTOR, 13P, FEMALE コネクタ (メス)	
	VT2 - 5161 - 026		1	HOLDER, CONNECTOR, 26P コネクタ ホルダ	
J 510	PCB			DC CONTROLLER DCコントローラ	
	VS1 - 6313 - 016		1	CONNECTOR, 16P, FEMALE コネクタ (メス)	
	VS1 - 6314 - 016		1	CONNECTOR, 16P, FEMALE コネクタ (メス)	
	VT2 - 5161 - 032		1	HOLDER, CONNECTOR, 32P コネクタ ホルダ	
J 511	PCB			DC CONTROLLER DCコントローラ	
	VS1 - 6313 - 014		1	CONNECTOR, 14P, FEMALE コネクタ (メス)	
	VS1 - 6314 - 014		1	CONNECTOR, 14P, FEMALE コネクタ (メス)	
J 512	VT2 - 5161 - 028		1	HOLDER, CONNECTOR, 28P コネクタ ホルダ	
	PCB			DC CONTROLLER DCコントローラ	
	VS1 - 6313 - 015		1	CONNECTOR, 15P, FEMALE コネクタ (メス)	
	VS1 - 6314 - 015		1	CONNECTOR, 15P, FEMALE コネクタ (メス)	
	VT2 - 5161 - 030		1	HOLDER, CONNECTOR, 30P コネクタ ホルダ	
J 513	PCB			DC CONTROLLER DCコントローラ	
	VS1 - 6313 - 013		1	CONNECTOR, 13P, FEMALE コネクタ (メス)	
	VS1 - 6314 - 013		1	CONNECTOR, 13P, FEMALE コネクタ (メス)	
	VT2 - 5161 - 026		1	HOLDER, CONNECTOR, 26P コネクタ ホルダ	
J 514	PCB			DC CONTROLLER DCコントローラ	

FIGURE & KEY NO.	PART NUMBER	RANK	QTY	DESCRIPTION	SERIAL NUMBER / REMARKS
B - J 514	VS1 - 6313 - 014		1	CONNECTOR, 14P, FEMALE コネクタ (メス)	
	VS1 - 6314 - 014		1	CONNECTOR, 14P, FEMALE コネクタ (メス)	
	VT2 - 5161 - 028		1	HOLDER, CONNECTOR, 28P コネクタ ホルダ	
	J 515	PCB		DC CONTROLLER DCコントローラ	
	VS1 - 6313 - 013		1	CONNECTOR, 13P, FEMALE コネクタ (メス)	
J 516	VS1 - 6314 - 013		1	CONNECTOR, 13P, FEMALE コネクタ (メス)	
	VT2 - 5161 - 026		1	HOLDER, CONNECTOR, 26P コネクタ ホルダ	
	PCB			DC CONTROLLER DCコントローラ	
	VS1 - 6313 - 012		1	CONNECTOR, 12P, FEMALE コネクタ (メス)	
	VS1 - 6314 - 012		1	CONNECTOR, 12P, FEMALE コネクタ (メス)	
J 517	VT2 - 5161 - 024		1	HOLDER, CONNECTOR, 24P コネクタ ホルダ	
	PCB			DC CONTROLLER DCコントローラ	
	VS1 - 6313 - 013		1	CONNECTOR, 13P, FEMALE コネクタ (メス)	
	VS1 - 6314 - 013		1	CONNECTOR, 13P, FEMALE コネクタ (メス)	
	VT2 - 5161 - 026		1	HOLDER, CONNECTOR, 26P コネクタ ホルダ	
J 518	PCB			DC CONTROLLER DCコントローラ	
	VS1 - 6313 - 010		1	CONNECTOR, 10P, FEMALE コネクタ (メス)	
	VS1 - 6314 - 010		1	CONNECTOR, 10P, FEMALE コネクタ (メス)	
	VT2 - 5161 - 020		1	HOLDER, CONNECTOR, 20P コネクタ ホルダ	
J 519	PCB			DC CONTROLLER DCコントローラ	
J 520	VS1 - 6313 - 016		1	CONNECTOR, 16P, FEMALE コネクタ (メス)	
	VS1 - 6314 - 016		1	CONNECTOR, 16P, FEMALE コネクタ (メス)	
	VT2 - 5161 - 032		1	HOLDER, CONNECTOR, 32P コネクタ ホルダ	
	PCB			DC CONTROLLER DCコントローラ	
	VS1 - 6302 - 004		1	CONNECTOR, 4P, FEMALE コネクタ (メス)	
J 523	WS3 - 5680 - 000		4	SOCKET CONTACT, 20-24AWG ソケット コンタクト	
	PCB			DC CONTROLLER DCコントローラ	
	VS1 - 6314 - 004		1	CONNECTOR, 4P, FEMALE コネクタ (メス)	
J 526	PCB			DC CONTROLLER DCコントローラ	
	VS1 - 6314 - 007		1	CONNECTOR, 7P, FEMALE コネクタ (メス)	

FIGURE & KEY NO.	PART NUMBER	RANK	QTY	DESCRIPTION	SERIAL NUMBER / REMARKS
B - J 529	PCB			DC CONTROLLER DCコントローラ	
	VS1 - 6314 - 004		1	CONNECTOR, 4P, FEMALE コネクタ (メス)	
J 601	NPN			DRUM MOTOR ドラム モータ	M0
	VS3 - 5083 - 002		1	CONNECTOR, 2P, FEMALE コネクタ (メス)	
	WS3 - 5160 - 000		2	SOCKET CONTACT, 18-24AWG ソケット コンタクト	
J 602	NPN			DRUM MOTOR ドラム モータ	
	VS1 - 6321 - 005		1	CONNECTOR, 5P, FEMALE コネクタ (メス)	
J 611	NPN			MAIN MOTOR メイン モータ	M1
	VS3 - 5083 - 002		1	CONNECTOR, 2P, FEMALE コネクタ (メス)	
	WS3 - 5160 - 000		2	SOCKET CONTACT, 18-24AWG ソケット コンタクト	
J 612	NPN			MAIN MOTOR メイン モータ	M1
	VS1 - 6321 - 005		1	CONNECTOR, 5P, FEMALE コネクタ (メス)	
J 621	NPN			PAPER PICK-UP MOTOR 給紙モータ	M2
	VS3 - 5083 - 002		1	CONNECTOR, 2P, FEMALE コネクタ (メス)	
	WS3 - 5160 - 000		2	SOCKET CONTACT, 18-24AWG ソケット コンタクト	
J 622	NPN			PAPER PICK-UP MOTOR 給紙モータ	
	VS1 - 6321 - 005		1	CONNECTOR, 5P, FEMALE コネクタ (メス)	
J 651	NPN			FIXING DRIVE MOTOR 定着駆動モータ	M3
	VS3 - 5083 - 002		1	CONNECTOR, 2P, FEMALE コネクタ (メス)	
	WS3 - 5160 - 000		2	SOCKET CONTACT, 18-24AWG ソケット コンタクト	
J 652	NPN			FIXING DRIVE MOTOR 定着駆動モータ	M3
	VS1 - 6321 - 006		1	CONNECTOR, 6P, FEMALE コネクタ (メス)	
J 701	PCB			MACHINE POWER SUPPLY 本体電源	
	VS3 - 5083 - 007		1	CONNECTOR, 7P, FEMALE コネクタ (メス)	
	WS3 - 5160 - 000		4	SOCKET CONTACT, 18-24AWG ソケット コンタクト	
J 721	PCB			HIGH VOLTAGE DC TRANSFORMER 高圧DCトランス	
	VS1 - 6302 - 004		1	CONNECTOR, 4P, FEMALE コネクタ (メス)	
	WS3 - 5569 - 000		4	SOCKET CONTACT, 22-28AWG ソケット コンタクト	
J 722	PCB			HIGH VOLTAGE DC TRANSFORMER 高圧DCトランス	
	VS1 - 6302 - 005		1	CONNECTOR, 5P, FEMALE コネクタ (メス)	

FIGURE & KEY NO.	PART NUMBER	RANK	QTY	DESCRIPTION	SERIAL NUMBER / REMARKS
B - J 722	WS3 - 5569 - 000		5	SOCKET CONTACT, 22-28AWG ソケット コンタクト	
J 723	PCB			HIGH VOLTAGE DC TRANSFORMER 高圧DCトランス	
	VS1 - 6314 - 016		1	CONNECTOR, 16P, FEMALE コネクタ (メス)	
J 731	PCB			HIGH VOLTAGE DC TRANSFORMER 高圧DCトランス	
	FH2 - 9231 - 000		1	JOINT CONNECTOR UNIT 連結コネクタ ユニット	
J 732	PCB			HIGH VOLTAGE DC TRANSFORMER 高圧DCトランス	
	FH2 - 9231 - 000		1	JOINT CONNECTOR UNIT 連結コネクタ ユニット	
J 733	PCB			HIGH VOLTAGE DC TRANSFORMER 高圧DCトランス	
	FH2 - 9231 - 000		1	JOINT CONNECTOR UNIT 連結コネクタ ユニット	
J 734	PCB			HIGH VOLTAGE DC TRANSFORMER 高圧DCトランス	
J 737	NPN			AC TRANSFORMER ACトランス	
	PCB			HIGH VOLTAGE DC TRANSFORMER 高圧DCトランス	
	VS3 - 5083 - 002		1	CONNECTOR, 2P, FEMALE コネクタ (メス)	
	WS3 - 5160 - 000		1	SOCKET CONTACT, 18-24AWG ソケット コンタクト	
J 741	PCB			HIGH VOLTAGE AC TRANSFORMER 高圧ACトランス	
J 742	VS1 - 6302 - 005		1	CONNECTOR, 5P, FEMALE コネクタ (メス)	
	WS3 - 5569 - 000		5	SOCKET CONTACT, 22-28AWG ソケット コンタクト	
	PCB			HIGH VOLTAGE AC TRANSFORMER 高圧ACトランス	
	NPN			AC TRANSFORMER ACトランス	
J 761	PCB			POLYGON MOTOR DRIVER ポリゴン モータ ドライバ	
J 762	VS3 - 5083 - 003		1	CONNECTOR, 3P, FEMALE コネクタ (メス)	
	WS3 - 5160 - 000		2	SOCKET CONTACT, 18-24AWG ソケット コンタクト	
	PCB			POLYGON MOTOR DRIVER ポリゴン モータ ドライバ	
	VS1 - 6321 - 004		1	CONNECTOR, 4P, FEMALE コネクタ (メス)	
J 763	PCB			POLYGON MOTOR DRIVER ポリゴン モータ ドライバ	
J 764	VS1 - 6302 - 011		1	CONNECTOR, 11P, FEMALE コネクタ (メス)	
	WS3 - 5569 - 000		11	SOCKET CONTACT, 22-28AWG ソケット コンタクト	
	NPN			POLYGON MOTOR ポリゴン モータ	M4
	VS3 - 0315 - 011		1	CONNECTOR, 11P, FEMALE コネクタ (メス)	
	WS3 - 1091 - 000		11	SOCKET CONTACT ソケット コンタクト	

FIGURE & KEY NO.	PART NUMBER	RANK	QTY	DESCRIPTION	SERIAL NUMBER / REMARKS
B - J 781	PCB			EVERYNIGHT POWER 常夜電源	
	VS1 - 6380 - 003		1	CONNECTOR, 3P, MALE コネクタ (オス)	
J 782	WS3 - 5292 - 000		2	SOCKET CONTACT ソケット コンタクト	
	PCB			EVERYNIGHT POWER 常夜電源	
	VS3 - 5083 - 006		1	CONNECTOR, 6P, FEMALE コネクタ (メス)	
J 783	WS3 - 5160 - 000		4	SOCKET CONTACT, 18-24AWG ソケット コンタクト	
	PCB			EVERYNIGHT POWER 常夜電源	
	VS1 - 6302 - 006		1	CONNECTOR, 6P, FEMALE コネクタ (メス)	
J 784	WS3 - 5680 - 000		6	SOCKET CONTACT, 20-24AWG ソケット コンタクト	
	PCB			EVERYNIGHT POWER 常夜電源	
J 785	VS1 - 6321 - 003		1	CONNECTOR, 3P, FEMALE コネクタ (メス)	
	PCB			EVERYNIGHT POWER 常夜電源	
J 791	VS1 - 6321 - 004		1	CONNECTOR, 4P, FEMALE コネクタ (メス)	
	PCB			AC DRIVER ACドライバ	
	VS1 - 6302 - 004		1	CONNECTOR, 4P, FEMALE コネクタ (メス)	
J 792	WS3 - 5569 - 000		4	SOCKET CONTACT, 22-28AWG ソケット コンタクト	
	PCB			AC DRIVER SUB ACドライバ サブ	
J 801	VS1 - 6321 - 012		1	CONNECTOR, 12P, FEMALE コネクタ (メス)	
	PCB			SCANNER MOTOR DRIVER 光学モータ ドライバ	
	VS3 - 5083 - 007		1	CONNECTOR, 7P, FEMALE コネクタ (メス)	
J 802	WS3 - 5160 - 000		7	SOCKET CONTACT, 18-24AWG ソケット コンタクト	
	PCB			SCANNER MOTOR DRIVER 光学モータ ドライバ	
J 803	VS1 - 6321 - 012		1	CONNECTOR, 12P, FEMALE コネクタ (メス)	
	PCB			SCANNER MOTOR DRIVER 光学モータ ドライバ	
	NPN			SCANNER MOTOR 光学モータ	M5
J 804	PCB			SCANNER MOTOR DRIVER 光学モータ ドライバ	
	VS1 - 6321 - 003		1	CONNECTOR, 3P, FEMALE コネクタ (メス)	
J 851	PCB			EXPOSURE CONTROLLER 調光制御	
	VS3 - 5083 - 004		1	CONNECTOR, 4P, FEMALE コネクタ (メス)	
	WS3 - 5160 - 000		4	SOCKET CONTACT, 18-24AWG ソケット コンタクト	

FIGURE & KEY NO.	PART NUMBER	RANK	QTY	DESCRIPTION	SERIAL NUMBER / REMARKS
B - J 852	PCB			EXPOSURE CONTROLLER 調光制御	
	FH2 - 6574 - 000		1	CABLE, FLUORESCENT 蛍光灯束線	
J 853	PCB			EXPOSURE CONTROLLER 調光制御	
	VS1 - 6321 - 005		1	CONNECTOR, 5P, FEMALE コネクタ (メス)	
J 901	VS1 - 5057 - 003		1	CONNECTOR, SNAP TIGHT チュウケイ コネクタ	
	VS1 - 6321 - 003		2	CONNECTOR, 3P, FEMALE コネクタ (メス)	
J 902	NPN			WRITING SENSOR 書き込みセンサ	PS60
	VS1 - 6321 - 003		1	CONNECTOR, 3P, FEMALE コネクタ (メス)	
J 943	PCB			INVERTER POWER インバータ電源	
	VS3 - 5083 - 004		1	CONNECTOR, 4P, FEMALE コネクタ (メス)	
	WS3 - 5160 - 000		4	SOCKET CONTACT, 18-24AWG ソケット コンタクト	
J 1001	PCB			FLUORESCENT LAMP INVERTER 蛍光灯インバータ	
	VS3 - 5083 - 002		1	CONNECTOR, 2P, FEMALE コネクタ (メス)	
	WS3 - 5160 - 000		2	SOCKET CONTACT, 18-24AWG ソケット コンタクト	
J 1002	PCB			FLUORESCENT LAMP INVERTER 蛍光灯インバータ	
	VS1 - 6321 - 008		1	CONNECTOR, 8P, FEMALE コネクタ (メス)	
J 1003	PCB			FLUORESCENT LAMP INVERTER 蛍光灯インバータ	
	FH2 - 6574 - 000		1	CABLE, FLUORESCENT 蛍光灯束線	
J 1006	PCB			MAIN CONTROLLER メイン コントローラ	
	VS1 - 6314 - 009		1	CONNECTOR, 9P, FEMALE コネクタ (メス)	
J 1014	PCB			MAIN CONTROLLER メイン コントローラ	
	VS1 - 6407 - 080		1	CONNECTOR, 80P, FEMALE コネクタ (メス)	
J 1015	PCB			PIXEL/LINE CHANGE 画素/ライン変換	
	PCB			MAIN CONTROLLER メイン コントローラ	
J 1017	PCB			MAIN CONTROLLER メイン コントローラ	
	VS1 - 6619 - 040		1	CONNECTOR, 40P, FEMALE コネクタ (メス)	
J 1018	PCB			MAIN CONTROLLER メイン コントローラ	
	VS1 - 6313 - 018		2	CONNECTOR, 18P, FEMALE コネクタ (メス)	
	VT2 - 5161 - 036		1	HOLDER, CONNECTOR, 36P コネクタ ホルダ	
J 1019	PCB			MAIN CONTROLLER メイン コントローラ	

FIGURE & KEY NO.	PART NUMBER	R A N K	Q' T Y	DESCRIPTION	SERIAL NUMBER / REMARKS
B - J 1019	VS1 - 6313 - 013		2	CONNECTOR, 13P, FEMALE コネクタ (メス)	
	VT2 - 5161 - 026		1	HOLDER, CONNECTOR, 26P コネクタ ホルダ	
	J 1020 PCB			MAIN CONTROLLER メイン コントローラ	
	VS1 - 6302 - 015		1	CONNECTOR, 15P, MALE コネクタハウジング	
	WS3 - 5680 - 000		14	SOCKET CONTACT, 20-24AWG ソケット コンタクト	
J 1021	PCB			MAIN CONTROLLER メイン コントローラ	
	VS1 - 6314 - 003		1	CONNECTOR, 3P, FEMALE コネクタ (メス)	
J 1022	PCB			MAIN CONTROLLER メイン コントローラ	
	VS1 - 6321 - 006		1	CONNECTOR, 6P, FEMALE コネクタ (メス)	
J 1023	PCB			MAIN CONTROLLER メイン コントローラ	
J 1024	VS1 - 6314 - 011		1	CONNECTOR, 11P, FEMALE コネクタ (メス)	
	PCB			MAIN CONTROLLER メイン コントローラ	
	VS1 - 6314 - 010		1	CONNECTOR, 10P, FEMALE コネクタ (メス)	
J 1027	PCB			MAIN CONTROLLER メイン コントローラ	
	VS1 - 6302 - 002		1	CONNECTOR, 2P, FEMALE コネクタ (メス)	
J 1028	WS3 - 5680 - 000		2	SOCKET CONTACT, 20-24AWG ソケット コンタクト	FM16
	PCB			MAIN CONTROLLER メイン コントローラ	
	NPN			SYSTEM FAN システム ファン	
J 1058	PCB			MAIN CONTROLLER メイン コントローラ	
	VS1 - 6302 - 004		1	CONNECTOR, 4P, FEMALE コネクタ (メス)	
J 1060	WS3 - 5680 - 000		4	SOCKET CONTACT, 20-24AWG ソケット コンタクト	
	PCB			MAIN CONTROLLER メイン コントローラ	
	VS1 - 6321 - 004		1	CONNECTOR, 4P, FEMALE コネクタ (メス)	
J 1061	PCB			MAIN CONTROLLER メイン コントローラ	
	VS1 - 6314 - 004		1	CONNECTOR, 4P, FEMALE コネクタ (メス)	
J 1091	NPN			HARD DISK ハード ディスク	
	X62 - 5133 - 000		4	SOCKET CONTACT, 18-24AWG ソケット コンタクト	
J 1101	PCB			READER CONTROLLER リーダー コントローラ	
	VS1 - 6302 - 008		1	CONNECTOR, 8P, FEMALE コネクタ (メス)	
	WS3 - 5569 - 000		8	SOCKET CONTACT, 22-28AWG ソケット コンタクト	

FIGURE & KEY NO.	PART NUMBER	RANK	QTY	DESCRIPTION	SERIAL NUMBER / REMARKS
B - J1102	PCB			READER CONTROLLER リーダ コントローラ	
	VS1 - 6302 - 009		1	CONNECTOR, 9P, FEMALE コネクタ (メス)	
J1103	WS3 - 5680 - 000		8	SOCKET CONTACT, 20-24AWG ソケット コンタクト	
	PCB			DOCUMENT DETECT 原稿向き検知	
	PCB			READER CONTROLLER リーダ コントローラ	
J1104	PCB			READER CONTROLLER リーダ コントローラ	
	FH2 - 6756 - 000		1	CABLE, DDI-S INTERFACE DDI-S I/Fケーブル	
J1107	PCB			READER CONTROLLER リーダ コントローラ	
	FH2 - 6899 - 000		1	CABLE, FLAT フラット ケーブル	
J1108	PCB			READER CONTROLLER リーダ コントローラ	
	FH2 - 6898 - 000		1	CABLE, FLAT フラット ケーブル	
J1109	PCB			READER CONTROLLER リーダ コントローラ	
	VS1 - 6313 - 013		1	CONNECTOR, 13P, FEMALE コネクタ (メス)	
	VS1 - 6314 - 013		1	CONNECTOR, 13P, FEMALE コネクタ (メス)	
	VT2 - 5161 - 026		1	HOLDER, CONNECTOR, 26P コネクタ ホルダ	
J1110	PCB			READER CONTROLLER リーダ コントローラ	
	VS1 - 6313 - 010		1	CONNECTOR, 10P, FEMALE コネクタ (メス)	
	VS1 - 6314 - 010		1	CONNECTOR, 10P, FEMALE コネクタ (メス)	
	VT2 - 5161 - 020		1	HOLDER, CONNECTOR, 20P コネクタ ホルダ	
J1112	PCB			READER CONTROLLER リーダ コントローラ	
	VS1 - 6314 - 012		1	CONNECTOR, 12P, FEMALE コネクタ (メス)	
J1113	PCB			READER CONTROLLER リーダ コントローラ	
	VS1 - 6314 - 004		1	CONNECTOR, 4P, FEMALE コネクタ (メス)	
J1114	PCB			READER CONTROLLER リーダ コントローラ	
	VS1 - 6321 - 006		1	CONNECTOR, 6P, FEMALE コネクタ (メス)	
J1301	PCB			LASER DRIVER 1 レーザ ドライバ(1)	
	PCB			LASER DRIVER 2 レーザ ドライバ(2)	
J1302	PCB			LASER DRIVER 2 レーザ ドライバ(2)	
	FH2 - 6900 - 000		1	CABLE, SHIELD シールド ケーブル	
J1303	PCB			LASER DRIVER 2 レーザ ドライバ(2)	

FIGURE & KEY NO.	PART NUMBER	RANK	QTY	DESCRIPTION	SERIAL NUMBER / REMARKS
B - J 1303	VS1 - 6314 - 016		1	CONNECTOR, 16P, FEMALE コネクタ (メス)	
J 1304	PCB			LASER DRIVER 2 レーザ ドライバ (2)	
J 1305	VS1 - 6314 - 006		1	CONNECTOR, 6P, FEMALE コネクタ (メス)	
	PCB			LASER DRIVER 1 レーザ ドライバ (1)	
	VS1 - 6302 - 004		1	CONNECTOR, 4P, FEMALE コネクタ (メス)	
J 1451	WS3 - 5680 - 000		4	SOCKET CONTACT, 20-24AWG ソケット コンタクト	
	PCB			PIXEL/LINE CHANGE 画素/ライン変換	
	PCB			MAIN CONTROLLER メイン コントローラ	
J 1452	PCB			PIXEL/LINE CHANGE 画素/ライン変換	
	FH2 - 6900 - 000		1	CABLE, SHIELD シールド ケーブル	
J 1453	PCB			PIXEL/LINE CHANGE 画素/ライン変換	
	VS1 - 6313 - 014		1	CONNECTOR, 14P, FEMALE コネクタ (メス)	
	VS1 - 6314 - 014		1	CONNECTOR, 14P, FEMALE コネクタ (メス)	
	VT2 - 5161 - 028		1	HOLDER, CONNECTOR, 28P コネクタ ホルダ	
J 1454	PCB			PIXEL/LINE CHANGE 画素/ライン変換	
J 1461	VS3 - 5083 - 004		1	CONNECTOR, 4P, FEMALE コネクタ (メス)	
	WS3 - 5160 - 000		4	SOCKET CONTACT, 18-24AWG ソケット コンタクト	
	PCB			BICENTRO/DISPLAY INTERFACE バイセントロ/ディスプレイ インターフェース	
	VS1 - 6313 - 017		1	CONNECTOR, 17P, FEMALE コネクタ (メス)	
	VS1 - 6314 - 017		1	CONNECTOR, 17P, FEMALE コネクタ (メス)	
J 1501	VT2 - 5161 - 034		1	HOLDER, CONNECTOR, 34P コネクタ ホルダ	
	PCB			CCD CCD	
	VS1 - 6302 - 008		1	CONNECTOR, 8P, FEMALE コネクタ (メス)	
J 1502	WS3 - 5569 - 000		8	SOCKET CONTACT, 22-28AWG ソケット コンタクト	
	PCB			CCD CCD	
J 1503	FH2 - 6899 - 000		1	CABLE, FLAT フラット ケーブル	
	PCB			CCD CCD	
J 1551	FH2 - 6898 - 000		1	CABLE, FLAT フラット ケーブル	
	NPN			HARD DISK ハード ディスク	
	VS1 - 6619 - 040		1	CONNECTOR, 40P, FEMALE コネクタ (メス)	

FIGURE & KEY NO.	PART NUMBER	RANK	QTY	DESCRIPTION	SERIAL NUMBER / REMARKS
B - J 1701	PCB			RELAY リレー	
	PCB			MACHINE POWER SUPPLY 本体電源	
	J 1702 PCB			RELAY リレー	
J 1703	PCB			MACHINE POWER SUPPLY 本体電源	
	PCB			RELAY リレー	
J 1704	PCB			MACHINE POWER SUPPLY 本体電源	
	PCB			RELAY リレー	
J 1705	PCB			MACHINE POWER SUPPLY 本体電源	
	PCB			RELAY リレー	
J 1706	PCB			MACHINE POWER SUPPLY 本体電源	
	PCB			RELAY リレー	
J 1712	PCB			MACHINE POWER SUPPLY 本体電源	
	VS1 - 6302 - 008		1	CONNECTOR, 8P, FEMALE コネクタ (メス)	
	WS3 - 5680 - 000		8	SOCKET CONTACT, 20-24AWG ソケット コンタクト	
J 1713	PCB			RELAY リレー	
	VS3 - 5083 - 015		1	CONNECTOR, 15P, FEMALE コネクタ (メス)	
J 1714	PCB			RELAY リレー	
	VS1 - 6302 - 012		1	CONNECTOR, 12P, FEMALE コネクタ (メス)	
J 1715	WS3 - 5680 - 000		12	SOCKET CONTACT, 20-24AWG ソケット コンタクト	
	PCB			RELAY リレー	
J 1716	VS1 - 6302 - 003		1	CONNECTOR, 3P, FEMALE コネクタ (メス)	
	WS3 - 5680 - 000		2	SOCKET CONTACT, 20-24AWG ソケット コンタクト	
J 1718	PCB			RELAY リレー	
	VS1 - 6302 - 015		1	CONNECTOR, 15P, MALE コネクタハウジング	
	WS3 - 5680 - 000		14	SOCKET CONTACT, 20-24AWG ソケット コンタクト	
	VS3 - 5083 - 007		1	CONNECTOR, 7P, FEMALE コネクタ (メス)	
	WS3 - 5160 - 000		6	SOCKET CONTACT, 18-24AWG ソケット コンタクト	

FIGURE & KEY NO.	PART NUMBER	R A N K	Q' T Y	DESCRIPTION	SERIAL NUMBER / REMARKS
B - J 1719	PCB			RELAY リレー	
	VS1 - 6314 - 010		1	CONNECTOR, 10P, FEMALE コネクタ (メス)	
J 1720	PCB			RELAY リレー	
	VS1 - 6302 - 008		1	CONNECTOR, 8P, FEMALE コネクタ (メス)	
	WS3 - 5680 - 000		8	SOCKET CONTACT, 20-24AWG ソケット コンタクト	
J 1721	PCB			RELAY リレー	
	VS1 - 6302 - 013		1	CONNECTOR, 13P, FEMALE コネクタ (メス)	
	WS3 - 5680 - 000		11	SOCKET CONTACT, 20-24AWG ソケット コンタクト	
J 1722	PCB			RELAY リレー	
	VS1 - 6302 - 002		1	CONNECTOR, 2P, FEMALE コネクタ (メス)	
J 1723	WS3 - 5680 - 000		2	SOCKET CONTACT, 20-24AWG ソケット コンタクト	
	PCB			RELAY リレー	
	VS1 - 6302 - 009		1	CONNECTOR, 9P, FEMALE コネクタ (メス)	
	WS3 - 5569 - 000		8	SOCKET CONTACT, 22-28AWG ソケット コンタクト	
J 1724	PCB			RELAY リレー	
J 1727	VS3 - 5083 - 008		1	CONNECTOR, 8P, FEMALE コネクタ (メス)	
	WS3 - 5160 - 000		8	SOCKET CONTACT, 18-24AWG ソケット コンタクト	
J 1728	PCB			RELAY リレー	
	VS1 - 6321 - 003		1	CONNECTOR, 3P, FEMALE コネクタ (メス)	
J 1901	VS1 - 6314 - 003		1	CONNECTOR, 3P, FEMALE コネクタ (メス)	
	PCB			DOCUMENT DETECT 原稿向き検知	
J 2030	PCB			READER CONTROLLER リーダー コントローラ	
	VS1 - 6302 - 004		1	CONNECTOR, 4P, FEMALE コネクタ (メス)	
	VS1 - 6702 - 004		1	CONNECTOR, 4P, FEMALE コネクタ (XA4P)	
J 2031	WS3 - 5569 - 000		4	SOCKET CONTACT, 22-28AWG ソケット コンタクト	FM13
	WS3 - 5720 - 000		4	SOCKET CONTACT, 22-28AWG ソケット コンタクト	
	NPN			SEPARATION FAN 分離ファン	
	VS1 - 6302 - 004		1	CONNECTOR, 4P, FEMALE コネクタ (メス)	
	WS3 - 5569 - 000		4	SOCKET CONTACT, 22-28AWG ソケット コンタクト	

FIGURE & KEY NO.	PART NUMBER	RANK	QTY	DESCRIPTION	SERIAL NUMBER / REMARKS
B - J 2270	VS1 - 5057 - 003		1	CONNECTOR, SNAP TIGHT チュウケイ コネクタ	
	VS1 - 6320 - 003		1	CONNECTOR, 3P, FEMALE コネクタ (メス)	
	VS1 - 6321 - 003		1	CONNECTOR, 3P, FEMALE コネクタ (メス)	
	J 3601 PCB			THROUGH-PATH スルーパス	
	FG6 - 8616 - 000		1	CABLE, THROUGH-PATH DRAWER スルーパス ドロア束線	
J 3602	PCB			THROUGH-PATH スルーパス	
	FG6 - 8616 - 000		1	CABLE, THROUGH-PATH DRAWER スルーパス ドロア束線	
J 3603	PCB			THROUGH-PATH スルーパス	
	FG6 - 8616 - 000		1	CABLE, THROUGH-PATH DRAWER スルーパス ドロア束線	
J 3604	PCB			THROUGH-PATH スルーパス	
J 3605	NPN			INVERT GUIDE SOLENOID 反転ガイド ソレノイド	SL11
	PCB			THROUGH-PATH スルーパス	
	FG6 - 8616 - 000		1	CABLE, THROUGH-PATH DRAWER スルーパス ドロア束線	
J 3607	PCB			THROUGH-PATH スルーパス	
	FG6 - 8616 - 000		1	CABLE, THROUGH-PATH DRAWER スルーパス ドロア束線	
J 3608	PCB			THROUGH-PATH スルーパス	
	FG6 - 8616 - 000		1	CABLE, THROUGH-PATH DRAWER スルーパス ドロア束線	
J 3609	PCB			THROUGH-PATH スルーパス	
	FG6 - 8616 - 000		1	CABLE, THROUGH-PATH DRAWER スルーパス ドロア束線	
J 3701	PCB			BEAM DETECT ビーム デテクタ	
J 5029	VS1 - 6314 - 005		1	CONNECTOR, 5P, FEMALE コネクタ (メス)	
	VS1 - 6314 - 004		2	CONNECTOR, 4P, FEMALE コネクタ (メス)	
	VS1 - 6318 - 004		1	CONNECTOR, SNAP TIGHT チュウケイ コネクタ	
J 5030	VS1 - 6314 - 005		2	CONNECTOR, 5P, FEMALE コネクタ (メス)	
	VS1 - 6318 - 005		1	CONNECTOR, SNAP TIGHT チュウケイ コネクタ	
J 5031	NPN			VIBRATION MOTOR バイブレーション モータ	M10
	VS1 - 5057 - 002		1	CONNECTOR, SNAP TIGHT チュウケイ コネクタ	
	VS1 - 6321 - 002		1	CONNECTOR, 2P, FEMALE コネクタ (メス)	
J 5032	NPN			VIBRATION MOTOR バイブレーション モータ	M20
	VS1 - 5057 - 002		1	CONNECTOR, SNAP TIGHT チュウケイ コネクタ	

FIGURE & KEY NO.	PART NUMBER	RANK	QTY	DESCRIPTION	SERIAL NUMBER / REMARKS
B - J5032	VS1 - 6321 - 002		1	CONNECTOR, 2P, FEMALE コネクタ (メス)	
J6801	PCB			CONTROL PANEL CPU 操作CPU	
	FH2 - 6791 - 000		1	CABLE, CONTROL 操作部束線	
J6802	PCB			CONTROL PANEL CPU 操作CPU	
	VS1 - 0842 - 015		1	CONNECTOR, 15P, FEMALE コネクタ (メス)	
J6803	PCB			CONTROL PANEL CPU 操作CPU	
	NPN			LCD CONTROL/ANALOG TOUCH PANEL 液晶パネル/アナログ タッチ パネル	
J6804	PCB			CONTROL PANEL CPU 操作CPU	
	VS1 - 0842 - 003		1	CONNECTOR, 3P, FEMALE コネクタ (メス)	
J6805	PCB			CONTROL PANEL CPU 操作CPU	
J7001	PCB			VS1 - 0842 - 014 CONNECTOR, 14P, FEMALE コネクタ (メス)	
	FH2 - 6791 - 000		1	BICENTRO/DISPLAY INTERFACE バイセントロ/ディスプレイ インターフェース	
J7002	PCB			BICENTRO/DISPLAY INTERFACE バイセントロ/ディスプレイ インターフェース	
	VS1 - 6313 - 018		1	CONNECTOR, 18P, FEMALE コネクタ (メス)	
J9001	PCB			VS1 - 6314 - 018 CONNECTOR, 18P, FEMALE コネクタ (メス)	
	VT2 - 5161 - 036		1	HOLDER, CONNECTOR, 36P コネクタ ホルダ	
J9201	PCB			SERIAL NUMBER シリアル ナンバ	
	VS1 - 6314 - 011		1	CONNECTOR, 11P, FEMALE コネクタ (メス)	
J9202	PCB			LVDS 差動	
	FH2 - 6756 - 000		1	CABLE, DDI-S INTERFACE DDI - S I/Fケーブル	
J9203	PCB			LVDS 差動	
	VS1 - 6314 - 004		1	CONNECTOR, 4P, FEMALE コネクタ (メス)	
J9802	PCB			CONTROL PANEL CPU 操作CPU	
	NPN			LCD CONTROL/ANALOG TOUCH PANEL 液晶パネル/アナログ タッチ パネル	

C LIST OF STANDARD FASTENERS

機械標準部品一覧表

I. SCREWS	C - 2	I. ネジ	C - 2
A. Machine screws		A. 精密機器用小ネジ	C - 3
(for precision use)	C - 3	B. ナベ小ネジ	C - 3
B. Pan head machine screws	C - 3	E. バインド小ネジ	C - 3
E. Binding head machine screws	C - 3	F. サラ小ネジ	C - 3
F. Flat head machine screws	C - 3	G. タッピンネジ	C - 3
G. Self-tapping screws	C - 3	H. バネ座金付き十字ナベ小ネジ	C - 3
H. Pan head machine screws with		K. TP小ネジ	C - 4
captive spring washer	C - 3	L. 六角穴付き止めネジおよび	
K. Washer head machine screws	C - 4	六角穴付きボルト	C - 4
L. Hex socket setscrews and		II. ナット	C - 4
socket head cap screws	C - 4	M. 六角ナット	C - 4
II. NUTS	C - 4	III. ワッシャ	C - 5
M. Hexagon nuts	C - 4	N. S & T. 標準ワッシャ	C - 5
III. WASHER AND SHIM WASHERS	C - 5	U. 平座金、バネ座金および	
N. S&T. Shim washers	C - 5	歯付き座金	C - 6
U. Plain Washers, spring washers&		IV. 止め輪	C - 7
toothed lock washers	C - 6	V. E形止め輪	C - 7
IV. RETAINING RINGS	C - 7	W. グリップ止め輪	C - 7
V. E rings	C - 7	X. C形止め輪	C - 8
W. Grip rings	C - 7	V. ピン	C - 9
X. C rings	C - 8	Y. スプリングピンおよび	
V. PINS	C - 9	平行ピン	C - 9
Y. Spring and dowel pins	C - 9	VI. スペーサ	C - 9
VI. SPACERS	C - 9	Z. スペーサ	C - 9
Z. Spacers	C - 9		

I. SCREWS

ネジ

How to read Part Numbers

部品番号の見方

Screws (except socket head cap screws)

ネジ (六角穴付ボルトを除く)

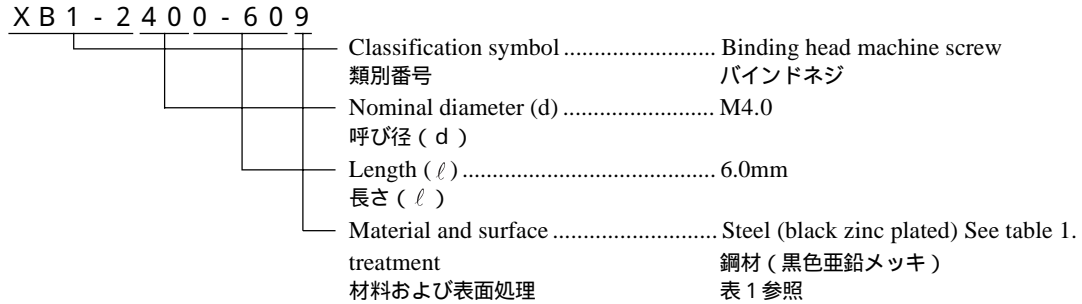

Socket head cap screws

六角穴付ボルト

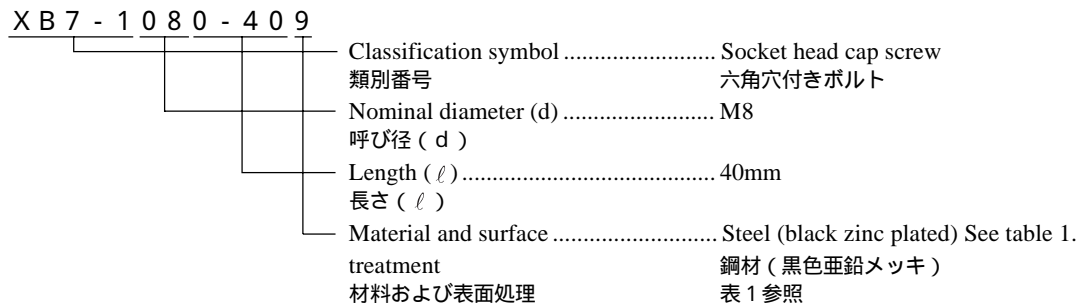

Material and surface treatment

No.	Material	Surface treatment	Color
1	Stainless	Blackened	Black
2		Without surface treatment	White
3	Brass	Nickel plated	White
4		Black nickel plated	Black
5	Steel	Zinc plated	Yellow
6		Nickel and chrome plated	White
7		Nickel plated	White
8		Phosphated	Black
9		Black zinc plated	Black

Table 1

材料および表面処理

番号	材質	表面処理	色
1	ステンレス	黒着色	黒
2		なし	白
3	黄銅	ニッケルメッキ	白
4		黒色ニッケルメッキ	黒
5	鋼	亜鉛メッキ	黄
6		ニッケルクロムメッキ	白
7		ニッケルメッキ	白
8		鉄鋼燐酸塩被膜	黒
9		黒色亜鉛メッキ	黒

表 1

A . MACHINE SCREWS (FOR PRECISION USE)

精密機器用小ネジ

Pan head machine Screws

ナベ小ネジ

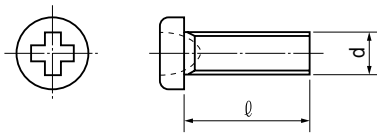

Flat head machine Screws

サラ小ネジ

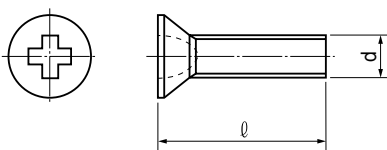

B . PAN HEAD MACHINE SCREWS

ナベ小ネジ

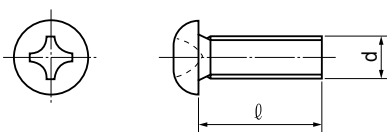

E . BINDING HEAD MACHINE SCREWS

バインド小ネジ

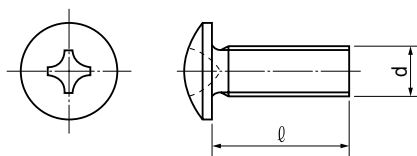

F . FLAT HEAD MACHINE SCREWS

サラ小ネジ

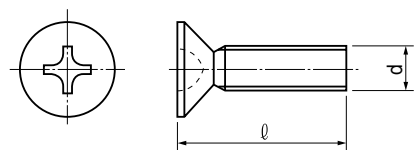

G . SELF-TAPPING SCREWS

タッピンネジ

Pan head self-tapping screws

ナベタッピンネジ

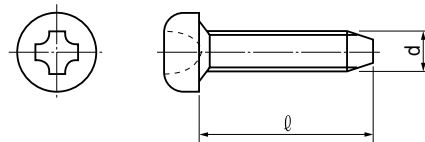

Binding head self-tapping screws

バインドタッピンネジ

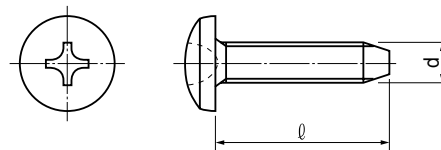

Flat head self-tapping screws

サラタッピンネジ

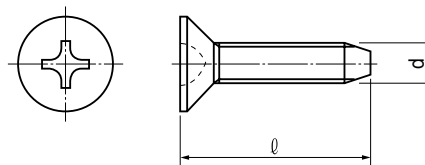

H . PAN HEAD MACHINE SCREWS WITH CAPTIVE SPRING WASHER

バネ座金付き十字ナベ小ネジ

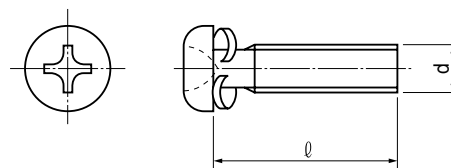

K - L

K . WASHER HEAD MACHINE SCREWS

TP小ネジ

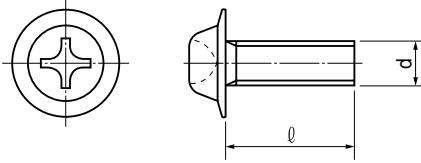

L . HEX SOCKET SETSCREWS AND SOCKET HEAD CAP SCREWS

六角穴付き止めネジおよび六角穴付きボルト

Hex socket setscrews
六角穴付き止めネジ

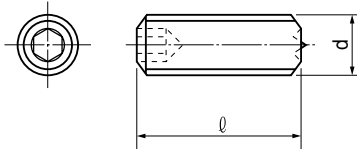

Socket head cap screws
六角穴付きボルト

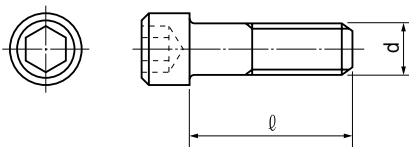

II . NUTS
ナット

M . HEXAGON NUTS

六角ナット

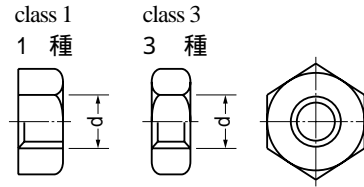

How to read Part Numbers

部品番号の見方

X B 7 - 2 1 0 0 - 3 0 9

Hexagon nut 六角ナット	Material and surface treatment	Nominal diameter (d) .. M3 呼び径 (d)	Steel (black zinc plated) 鋼材 (黒色亜鉛メッキ)
----------------------	---	---	---

XB7 - 210class 1
1種
XB7 - 220class 3
3種

III. WASHERS AND SHIM WASHERS ワッシャ

N . S&T . SHIM WASHERS 標準ワッシャ

How to read Part Numbers
部品番号の見方

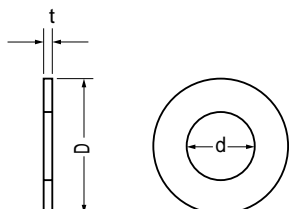

X D 1 - 1 1 0 2 - 6 2 5

Shim washer
標準ワッシャ

Inner diameter (d) ... 2.6mm
内径 (d)
Outer diameter (D) .. Class 2 (See table 2)
外径 (D) 2種 (表2参照)
Thickness code (t) ... 0.5mm
板厚番号 (t) See table 3.
表3参照

* Material : Brass
材料 : 黄銅

d (mm)	D (mm)		
	Class 1 1種	Class 2 2種	Class 3 3種
1.5	—	2.6	3.2
1.8	2.7	3.1	3.7
2.1	3.2	3.6	4.2
2.3	3.6	4	4.6
2.6	4	4.4	5
3.1	4.6	5	5.6
3.6	5.4	5.8	6.4
4.1	5.7	6.6	8
4.6	6.4	7.4	9
5.2	7.2	8.2	10
5.7	7.8	9	11
6.2	8.5	9.8	12
6.7	9.2	10.5	13
7.2	10	11.4	14
7.7	10.6	12.2	15
8.2	11.4	13	16
8.7	12	13.8	17
9.2	12.8	14.6	18
9.7	13.5	15.4	19

Table 2 表2

Thickness code 板厚番号	t (mm)
0	0.05
1	0.1
2	0.2
3	0.3
4	0.4
5	0.5
6	0.6
7	0.7
8	0.8
9	1

Table 3 表3

U

U . PLAIN WASHERS, SPRING WASHERS & TOOTHED LOCK WASHERS

平座金、バネ座金および歯付き座金

Plain washers
平座金

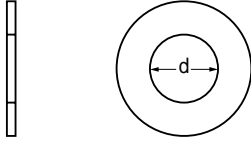

How to read Part Numbers
部品番号の見方

X D 1 - 2 1 0 0 - 3 0 7

Plain washer
平座金

Inner diameter (d) 3.0mm
呼び径 (d)
Material and surface
treatment Steel (nickel plated)
材料および表面処理 鋼材 (ニッケルメッキ)

Spring washers
バネ座金

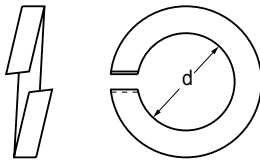

How to read Part Numbers
部品番号の見方

X D 1 - 3 1 0 0 - 5 0 7

Spring washer
バネ座金

Inner diameter (d) 5.0mm
呼び径 (d)
Material and surface
treatment Steel (nickel plated)
材料および表面処理 鋼材 (ニッケルメッキ)

Toothed lock washers
歯付き座金

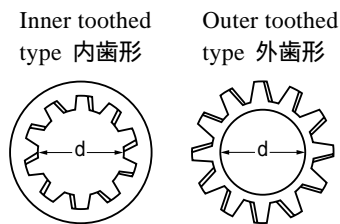

How to read Part Numbers
部品番号の見方

X D 1 - 4 1 0 0 - 3 0 2

Toothed lock washer
歯付き座金

Inner diameter (d) 3mm
呼び径 (d)
Material and surface
treatment Stainless (without
surface treatment)
材料および表面処理 ステンレス
(表面処理なし)

X D 1 - 4 1 0 . . . Inner toothed type
内歯形

X D 1 - 4 2 0 . . . Outer toothed type
外歯形

IV. RETAINING RINGS 止め輪

V. E RINGS E形止め輪

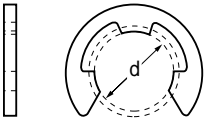

How to read Part Numbers
部品番号の見方

X D 2 - 1 1 0 0 - 1 7 2

E ring
E形止め輪

Inner diameter (d) 1.7mm
呼び径 (d)
Material and surface treatment
材料および表面処理

X D 2 - 1 1 0 ... class 1
1種

X D 2 - 1 2 0 ... class 2
2種

2 Stainless (without surface treatment)
ステンレス (表面処理なし)
7 Steel (nickel plated)
鋼材 (ニッケルメッキ)

W. GRIP RINGS グリップ止め輪

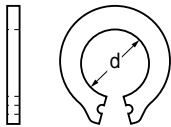

How to read Part Numbers
部品番号の見方

X D 2 - 2 1 0 0 - 5 0 2

Grip ring
グリップ止め輪

Inner diameter (d) 5.0mm
呼び径 (d)

Material and surface treatment Stainless (without surface treatment)
材料および表面処理 ステンレス (表面処理なし)

X . C RINGS

C形止め輪

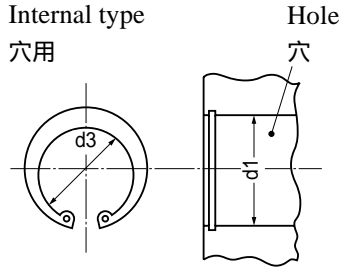
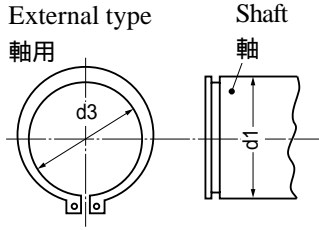

How to read Part Numbers
部品番号の見方

X D 2 - 3 1 0 0 - 2 0 2

C ring
C形止め輪

Nominal diameter (d) . 20mm
呼び径 (d)

Material and surface treatment
材料および表面処理

- 2 Stainless (without surface treatment)
ステンレス (表面処理なし)
- 8 Steel (phosphated)
鋼材 (鉄鋼磷酸塩被膜)

X D 2 - 3 1 0 ... External type
軸用

X D 2 - 3 2 0 ... Internal type
穴用

External type
軸用

Nominal diameter 呼び径	d1 (mm)	d3 (mm)
010	10	9.3
012	12	11.1
014	14	12.9
015	15	13.8
016	16	14.7
017	17	15.7
018	18	16.5
020	20	18.5
022	22	20.5
025	25	23.2
028	28	25.9
030	30	27.9
032	32	29.6
035	35	32.2

Table 4 表 4

Internal type
穴用

Nominal diameter 呼び径	d1 (mm)	d3 (mm)	Nominal diameter 呼び径	d1 (mm)	d3 (mm)
010	10	10.7	040	40	43.5
011	11	11.8	042	42	45.5
012	12	13	045	45	48.5
014	14	15.1	047	47	50.5
016	16	17.3	050	50	54.2
018	18	19.5	052	52	56.2
019	19	20.5	055	55	59.2
020	20	21.5	060	60	64.2
022	22	23.5	062	62	66.2
025	25	26.9	068	68	72.5
028	28	30.1	072	72	76.5
030	30	32.1	075	75	79.5
032	32	34.4	080	80	85.5
035	35	37.8	085	85	90.5
037	37	39.8	090	90	95.5
			095	95	100.5

Table 5 表 5

V. PINS ピン

Y. SPRING AND DOWEL PINS

スプリングピンおよび平行ピン

Spring pins
スプリングピン

How to read Part Numbers
部品番号の見方

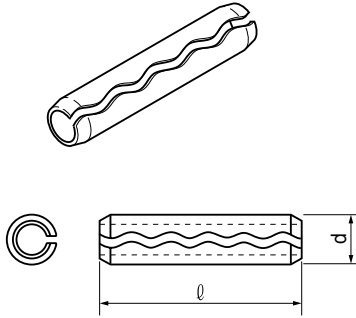

X D 3 - 1 2 0 0 - 1 2 2	
	Nominal diameter (D) .. 2.0mm
	呼び径 (D)
	Length (ℓ) 12mm
	長さ (ℓ)
	Material and surface treatment
	Stainless (without surface treatment)
	材料および表面処理
	ステンレス (表面処理なし)

Dowel pins
平行ピン

How to read Part Numbers
部品番号の見方

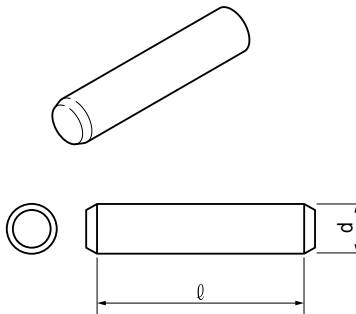

X D 3 - 2 2 0 0 - 0 8 2	
	Nominal diameter (d) ... 2.0mm
	呼び径 (d)
	Length (ℓ) 8mm
	長さ (ℓ)
	Material and surface treatment
	Stainless (without surface treatment)
	材料および表面処理
	ステンレス (表面処理なし)

VI. SPACERS スペーサ

Z. SPACERS スペーサ

How to read Part Numbers
部品番号の見方

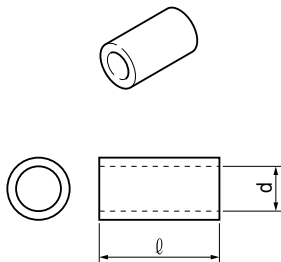

X Z 1 - 1 3 0 0 - 3 0 5	
	Nominal diameter (d) ... 3.0mm
	呼び径 (d)
	Length (ℓ) 3.0mm
	長さ (ℓ)
	Material and surface treatment
	Steel (zinc plated)
	材料および表面処理
	鋼 (亜鉛メッキ)

D NUMERICAL INDEX

部品索引表

PART NUMBER	FIGURE & KEY NO.	PART NUMBER	FIGURE & KEY NO.	PART NUMBER	FIGURE & KEY NO.
97 - 5527 - 000	550 - 1	FA9 - 3822 - 000	251 - 1	FB2 - 7631 - 020	311 - 11
	570 - 1		260 - 1	FB2 - 7633 - 000	311 - 12
FA2 - 1498 - 000	550 - 2		264 - 1		312 - 11
	580 - 1		275 - 1	FB2 - 7641 - 000	311 - 13
FA2 - 1753 - 000	320 - 1		360 - 3		312 - 12
FA2 - 7162 - 000	100 - 1		580 - 2	FB2 - 7642 - 000	311 - 14
FA2 - 8361 - 000	215 - 1		600 - 5		312 - 13
FA2 - 9037 - 000	810 - 1		640 - 3	FB2 - 7652 - 000	302 - 7
FA3 - 0515 - 000	640 - 1		810 - 6		303 - 7
FA3 - 2118 - 000	550 - 3	FA9 - 3827 - 000	311 - 3	FB2 - 7696 - 000	311 - 15
FA3 - 2128 - 000	570 - 2	FA9 - 3857 - 000	316 - 1		312 - 14
FA3 - 2394 - 000	510 - 7 A	FB1 - 0715 - 000	420 - 1		313 - 6
FA3 - 2395 - 000	510 - 7 B	FB1 - 6655 - 000	430 - 2	FB2 - 7715 - 020	313 - 7
FA3 - 2471 - 000	720 - 1	FB1 - 6663 - 000	430 - 3	FB2 - 7716 - 000	313 - 8
FA3 - 2472 - 000	720 - 2		430 - 4	FB2 - 7717 - 000	313 - 9
FA3 - 2473 - 000	720 - 3	FB1 - 6833 - 000	810 - 7	FB2 - 7718 - 000	313 - 10
FA3 - 2474 - 000	720 - 4	FB1 - 7041 - 000	360 - 4	FB2 - 7720 - 000	313 - 11
FA3 - 2475 - 000	720 - 5	FB1 - 7070 - 000	313 - 3	FB2 - 7721 - 000	313 - 12
FA3 - 2476 - 000	720 - 6	FB1 - 7109 - 000	210 - 3	FB2 - 7722 - 000	313 - 13
FA3 - 2477 - 000	720 - 7		210 - 4	FB2 - 7723 - 000	313 - 14
FA3 - 2478 - 000	720 - 8	FB1 - 7112 - 000	210 - 5	FB2 - 7724 - 000	313 - 15
FA3 - 2479 - 000	720 - 9	FB1 - 7157 - 000	100 - 3	FB2 - 7740 - 020	302 - 8
FA3 - 2480 - 000	720 - 10	FB1 - 8619 - 000	316 - 2		303 - 8
FA3 - 2481 - 000	720 - 11	FB1 - 8620 - 000	316 - 3		316 - 7
FA3 - 2565 - 000	570 - 3	FB1 - 8621 - 000	316 - 4	FB2 - 7750 - 000	100 - 6
FA3 - 2764 - 020	350 - 1	FB1 - 8625 - 000	316 - 5	FB2 - 7755 - 000	100 - 7
FA3 - 8004 - 000	570 - 4	FB1 - 8735 - 000	107 - 1		100 - 8
FA3 - 8727 - 000	315 - 1	FB1 - 8737 - 000	107 - 2		360 - 6
FA3 - 8894 - 000	810 - 2	FB2 - 0037 - 000	100 - 4	FB2 - 7758 - 000	303 - 9
FA3 - 9120 - 000	325 - 1	FB2 - 1035 - 000	320 - 2	FB2 - 7841 - 000	260 - 2
FA3 - 9315 - 000	130 - 1	FB2 - 1047 - 000	250 - 3	FB2 - 7864 - 000	100 - 9
FA4 - 0207 - 000	645 - 1	FB2 - 1382 - 000	215 - 2	FB2 - 7887 - 040	104 - 5
FA4 - 1149 - 000	325 - 2	FB2 - 1492 - 000	100 - 5		104 - 6
FA4 - 1819 - 000	600 - 1	FB2 - 1947 - 000	420 - 2	FB2 - 7888 - 030	104 - 7
FA4 - 2037 - 000	600 - 2	FB2 - 1954 - 000	420 - 3	FB2 - 7899 - 000	108 - 1
FA4 - 8609 - 000	940 - 1	FB2 - 2139 - 020	360 - 5	FB2 - 7900 - 000	108 - 2
FA5 - 2839 - 000	325 - 3	FB2 - 6043 - 000	300 - 2	FB2 - 7981 - 000	775 - 3
FA5 - 2872 - 000	313 - 1	FB2 - 6044 - 000	300 - 3	FB2 - 8002 - 030	102 - 1
FA5 - 2924 - 000	104 - 1	FB2 - 6285 - 000	325 - 4	FB2 - 8003 - 000	102 - 2
FA5 - 4266 - 000	315 - 2		775 - 2	FB2 - 8010 - 000	102 - 3
FA5 - 4400 - 000	810 - 3	FB2 - 6310 - 000	210 - 6		105 - 2
FA5 - 4403 - 000	810 - 4	FB2 - 6850 - 000	580 - 3	FB2 - 8021 - 000	100 - 10
FA6 - 0648 - 000	510 - 1	FB2 - 6897 - 000	600 - 4 9 A	FB2 - 8033 - 020	104 - 8
FA6 - 0745 - 000	100 - 2	FB2 - 7056 - 000	320 - 3	FB2 - 8041 - 000	103 - 1
FA6 - 3672 - 000	360 - 1	FB2 - 7096 - 000	580 - 4	FB2 - 8043 - 000	100 - 11
FA6 - 6457 - 000	311 - 1	FB2 - 7137 - 000	351 - 1	FB2 - 8102 - 000	100 - 12
FA6 - 7728 - 000	315 - 3	FB2 - 7163 - 000	350 - 2	FB2 - 8167 - 000	210 - 7
FA6 - 7737 - 000	315 - 4	FB2 - 7168 - 000	350 - 3	FB2 - 8192 - 000	320 - 6
FA6 - 7822 - 000	640 - 2	FB2 - 7169 - 000	350 - 4	FB2 - 8196 - 020	320 - 7
FA6 - 7865 - 000	600 - 3	FB2 - 7174 - 040	350 - 5	FB2 - 8198 - 000	320 - 8
FA6 - 7939 - 000	360 - 2	FB2 - 7181 - 000	351 - 2	FB2 - 8204 - 000	320 - 9
FA6 - 8003 - 000	810 - 5	FB2 - 7228 - 000	810 - 8	FB2 - 8213 - 000	320 - 10
FA6 - 8071 - 000	315 - 5	FB2 - 7238 - 000	810 - 9	FB2 - 8214 - 000	320 - 11
FA6 - 8304 - 000	250 - 1	FB2 - 7240 - 000	810 - 10	FB2 - 8217 - 020	320 - 12
FA6 - 9971 - 000	302 - 1	FB2 - 7242 - 000	320 - 4	FB2 - 8226 - 000	100 - 13
	303 - 1	FB2 - 7243 - 000	320 - 5	FB2 - 8227 - 000	315 - 12
FA6 - 9986 - 000	302 - 2	FB2 - 7261 - 000	810 - 11	FB2 - 8248 - 020	105 - 3
	303 - 2	FB2 - 7264 - 000	810 - 12	FB2 - 8266 - 000	311 - 16
FA6 - 9988 - 020	302 - 3	FB2 - 7515 - 020	315 - 7		312 - 15
	303 - 3	FB2 - 7521 - 000	316 - 6	FB2 - 8302 - 000	600 - 6
FA6 - 9989 - 000	302 - 4	FB2 - 7537 - 000	315 - 8	FB2 - 8345 - 000	101 - 3
	303 - 4	FB2 - 7542 - 000	315 - 9	FB2 - 8376 - 000	320 - 13
FA9 - 1449 - 000	460 - 1	FB2 - 7545 - 000	315 - 10	FB2 - 8384 - 000	315 - 13
FA9 - 1800 - 000	210 - 1	FB2 - 7558 - 000	315 - 11	FB2 - 8402 - 000	775 - 4
FA9 - 1969 - 000	104 - 2	FB2 - 7559 - 000	101 - 1	FB2 - 8410 - 000	311 - 17
	104 - 3	FB2 - 7560 - 000	101 - 2		312 - 16
FA9 - 1990 - 000	430 - 1	FB2 - 7593 - 000	311 - 4	FB2 - 8436 - 000	311 - 18
FA9 - 2112 - 000	261 - 1		312 - 3	FB2 - 8465 - 000	302 - 9
	302 - 5	FB2 - 7603 - 000	312 - 4		303 - 10
	303 - 5	FB2 - 7605 - 000	311 - 5	FB2 - 8506 - 000	108 - 3
	311 - 2		312 - 5	FB2 - 8512 - 000	311 - 19
	312 - 1	FB2 - 7606 - 000	311 - 6		312 - 17
	313 - 2		312 - 6		313 - 16
	775 - 1	FB2 - 7607 - 020	311 - 7	FB2 - 9248 - 000	231 - 1
FA9 - 2469 - 000	210 - 2	FB2 - 7614 - 000	312 - 7	FB3 - 2331 - 000	320 - 14
FA9 - 3622 - 000	105 - 1	FB2 - 7616 - 000	311 - 8	FB3 - 2411 - 000	420 - 4
FA9 - 3669 - 000	315 - 6		312 - 8		430 - 5
FA9 - 3674 - 000	300 - 1	FB2 - 7620 - 000	311 - 9	FB3 - 6117 - 000	510 - 7 C
FA9 - 3684 - 000	130 - 2	FB2 - 7623 - 000	313 - 4	FB3 - 7692 - 000	420 - 5
FA9 - 3691 - 000	312 - 2	FB2 - 7624 - 000	311 - 10		430 - 6
FA9 - 3730 - 000	600 - 4		312 - 9	FB3 - 8333 - 000	311 - 20
FA9 - 3805 - 000	280 - 1	FB2 - 7625 - 000	302 - 6	FB3 - 8369 - 000	350 - 6
FA9 - 3822 - 000	104 - 4		303 - 6	FB3 - 8398 - 000	320 - 15
	230 - 1	FB2 - 7630 - 000	312 - 10	FB3 - 8409 - 000	810 - 13
	250 - 2			FB3 - 8412 - 000	810 - 14

D NUMERICAL INDEX

部品索引表

PART NUMBER	FIGURE & KEY NO.	PART NUMBER	FIGURE & KEY NO.	PART NUMBER	FIGURE & KEY NO.
FB3 - 8414 - 000	350 - 7	FB4 - 1512 - 000	215 - 3	FB4 - 1824 - 000	640 - 7
FB3 - 8457 - 000	320 - 16	FB4 - 1521 - 000	215 - 4	FB4 - 1825 - 000	640 - 8
FB3 - 8508 - 000	302 - 10	FB4 - 1522 - 000	215 - 5	FB4 - 1828 - 000	640 - 9
	303 - 11	FB4 - 1532 - 000	215 - 6	FB4 - 1829 - 000	640 - 10
FB3 - 8615 - 000	261 - 2	FB4 - 1533 - 000	215 - 7	FB4 - 1830 - 000	640 - 17 A
FB3 - 8616 - 000	261 - 3	FB4 - 1534 - 000	215 - 8	FB4 - 1831 - 000	640 - 11
FB3 - 9303 - 020	300 - 4	FB4 - 1538 - 000	215 - 9	FB4 - 1837 - 000	640 - 12
FB3 - 9305 - 000	300 - 5	FB4 - 1539 - 020	215 - 10	FB4 - 1842 - 000	645 - 2
FB3 - 9306 - 000	300 - 6	FB4 - 1540 - 000	215 - 11	FB4 - 1849 - 000	645 - 3
FB3 - 9307 - 000	300 - 7	FB4 - 1542 - 000	110 - 1	FB4 - 1850 - 000	645 - 4
FB3 - 9308 - 000	300 - 8		111 - 1	FB4 - 1856 - 000	645 - 5
FB3 - 9311 - 000	300 - 9		770 - 2	FB4 - 1857 - 000	645 - 6
FB3 - 9312 - 000	300 - 10	FB4 - 1546 - 000	215 - 12	FB4 - 1858 - 000	645 - 7
FB3 - 9313 - 000	300 - 11	FB4 - 1550 - 000	215 - 13	FB4 - 1862 - 000	640 - 13
FB3 - 9314 - 000	300 - 12	FB4 - 1554 - 000	215 - 14	FB4 - 1866 - 000	640 - 14
FB3 - 9315 - 000	300 - 13	FB4 - 1557 - 020	120 - 4	FB4 - 1869 - 000	105 - 12 A
FB3 - 9316 - 000	300 - 14	FB4 - 1558 - 000	100 - 18	FB4 - 1892 - 000	275 - 2
FB3 - 9319 - 000	300 - 15	FB4 - 1564 - 000	215 - 15	FB4 - 1893 - 000	275 - 3
FB3 - 9320 - 000	300 - 16	FB4 - 1569 - 000	600 - 7	FB4 - 1894 - 000	275 - 4
FB3 - 9321 - 000	300 - 29 A	FB4 - 1570 - 000	600 - 8	FB4 - 1895 - 000	275 - 5
FB3 - 9322 - 020	300 - 17	FB4 - 1575 - 000	600 - 9	FB4 - 1896 - 000	275 - 6
FB3 - 9323 - 030	300 - 18	FB4 - 1576 - 000	600 - 10	FB4 - 1899 - 000	275 - 7
FB3 - 9326 - 000	300 - 19	FB4 - 1577 - 000	600 - 11	FB4 - 1900 - 000	275 - 8
FB3 - 9327 - 000	300 - 20	FB4 - 1584 - 000	600 - 12	FB4 - 1901 - 000	275 - 9
FB3 - 9329 - 000	300 - 29 B	FB4 - 1585 - 000	600 - 13	FB4 - 1902 - 000	275 - 10
FB3 - 9335 - 000	300 - 21	FB4 - 1590 - 000	600 - 14	FB4 - 1903 - 000	275 - 11
FB3 - 9336 - 000	300 - 29 C	FB4 - 1592 - 000	600 - 15	FB4 - 1904 - 000	275 - 12
FB3 - 9337 - 000	300 - 22	FB4 - 1594 - 000	600 - 16	FB4 - 1913 - 000	275 - 13
FB3 - 9340 - 000	300 - 23	FB4 - 1595 - 000	600 - 17	FB4 - 1915 - 000	275 - 14
FB3 - 9345 - 000	104 - 9	FB4 - 1600 - 000	600 - 18	FB4 - 1916 - 000	275 - 15
FB3 - 9356 - 000	104 - 10	FB4 - 1607 - 000	600 - 19	FB4 - 1924 - 000	275 - 16
FB3 - 9362 - 000	107 - 3	FB4 - 1609 - 000	600 - 20	FB4 - 1925 - 000	275 - 17
FB3 - 9363 - 000	107 - 4	FB4 - 1611 - 000	600 - 21	FB4 - 1926 - 000	275 - 18
FB3 - 9364 - 000	107 - 5	FB4 - 1612 - 000	600 - 22	FB4 - 1927 - 000	275 - 19
FB3 - 9372 - 000	810 - 15		910 - 1	FB4 - 1933 - 000	550 - 5
FB3 - 9907 - 000	100 - 66 B	FB4 - 1613 - 000	600 - 23	FB4 - 1940 - 000	550 - 6
FB3 - 9910 - 000	305 - 1 A	FB4 - 1616 - 000	600 - 50 A	FB4 - 1941 - 000	550 - 7
FB4 - 0464 - 000	640 - 4	FB4 - 1617 - 000	600 - 24	FB4 - 1947 - 000	940 - 2
FB4 - 0650 - 000	104 - 11	FB4 - 1618 - 000	600 - 25	FB4 - 1948 - 000	940 - 3
FB4 - 0715 - 000	210 - 8	FB4 - 1619 - 000	600 - 26	FB4 - 1953 - 000	106 - 5
FB4 - 0786 - 000	420 - 6	FB4 - 1620 - 000	510 - 3	FB4 - 1957 - 000	103 - 8
FB4 - 0787 - 000	420 - 7	FB4 - 1621 - 000	510 - 4	FB4 - 1960 - 000	100 - 22
FB4 - 0788 - 000	420 - 8	FB4 - 1622 - 000	510 - 5	FB4 - 1965 - 000	100 - 23
FB4 - 0789 - 000	420 - 9	FB4 - 1623 - 000	510 - 6		100 - 24
FB4 - 0795 - 000	420 - 10	FB4 - 1648 - 000	580 - 5	FB4 - 1967 - 000	100 - 25
FB4 - 0802 - 000	420 - 11	FB4 - 1650 - 000	580 - 6	FB4 - 1969 - 000	100 - 26
	430 - 7	FB4 - 1656 - 000	580 - 7		100 - 27
FB4 - 0804 - 000	420 - 12	FB4 - 1657 - 000	580 - 8	FB4 - 1970 - 000	100 - 28
FB4 - 0825 - 000	430 - 8	FB4 - 1667 - 000	325 - 24 A	FB4 - 1982 - 000	311 - 22
FB4 - 0831 - 000	430 - 9	FB4 - 1670 - 000	325 - 5	FB4 - 1989 - 000	311 - 23
FB4 - 0832 - 000	420 - 13	FB4 - 1679 - 000	325 - 6		312 - 18
FB4 - 0864 - 000	420 - 14	FB4 - 1680 - 020	570 - 5	FB4 - 1990 - 000	313 - 17
	430 - 10	FB4 - 1681 - 020	570 - 6	FB4 - 2000 - 000	312 - 19
FB4 - 0867 - 000	420 - 15	FB4 - 1682 - 000	570 - 7	FB4 - 2004 - 000	311 - 24
FB4 - 0868 - 000	420 - 15	FB4 - 1683 - 000	570 - 8		312 - 20
FB4 - 1202 - 000	311 - 21	FB4 - 1693 - 000	550 - 4	FB4 - 2007 - 000	311 - 25
FB4 - 1333 - 000	103 - 2		570 - 9		312 - 21
FB4 - 1334 - 000	108 - 4		580 - 9		313 - 18
FB4 - 1339 - 000	108 - 5	FB4 - 1694 - 000	570 - 10		315 - 14
FB4 - 1340 - 000	108 - 6	FB4 - 1695 - 000	570 - 11	FB4 - 2009 - 000	312 - 22
FB4 - 1341 - 000	104 - 12	FB4 - 1696 - 000	570 - 12	FB4 - 2010 - 000	312 - 23
FB4 - 1342 - 000	104 - 13	FB4 - 1712 - 000	210 - 22 A	FB4 - 2012 - 000	312 - 24
FB4 - 1350 - 000	102 - 4	FB4 - 1713 - 000	210 - 36 A	FB4 - 2019 - 000	104 - 15
FB4 - 1354 - 000	106 - 1	FB4 - 1714 - 000	210 - 22 B	FB4 - 2023 - 000	104 - 16
FB4 - 1355 - 000	104 - 14	FB4 - 1715 - 000	210 - 36 B	FB4 - 2024 - 000	104 - 17
FB4 - 1359 - 000	100 - 14	FB4 - 1717 - 000	100 - 19	FB4 - 2026 - 000	302 - 11
FB4 - 1386 - 000	101 - 4	FB4 - 1719 - 000	325 - 7		303 - 12
FB4 - 1391 - 000	100 - 15	FB4 - 1727 - 000	100 - 20	FB4 - 2031 - 000	313 - 19
FB4 - 1407 - 000	101 - 11 A	FB4 - 1734 - 000	210 - 10	FB4 - 2035 - 000	315 - 15
FB4 - 1409 - 000	101 - 10 A	FB4 - 1735 - 000	100 - 21	FB4 - 2041 - 000	103 - 9
FB4 - 1410 - 000	103 - 3	FB4 - 1740 - 000	210 - 36 C	FB4 - 2042 - 000	103 - 10
FB4 - 1411 - 000	103 - 4	FB4 - 1750 - 000	106 - 2		103 - 11
FB4 - 1416 - 000	510 - 2	FB4 - 1753 - 000	106 - 3	FB4 - 2061 - 000	320 - 17
FB4 - 1418 - 000	103 - 5	FB4 - 1762 - 000	280 - 2	FB4 - 2062 - 000	320 - 18
	103 - 6	FB4 - 1766 - 000	250 - 4	FB4 - 2067 - 000	320 - 19
FB4 - 1421 - 000	103 - 7	FB4 - 1781 - 000	106 - 4	FB4 - 2068 - 000	320 - 20
FB4 - 1423 - 000	100 - 16	FB4 - 1792 - 000	775 - 5		325 - 8
FB4 - 1428 - 000	210 - 9	FB4 - 1794 - 000	775 - 6	FB4 - 2077 - 000	320 - 21
FB4 - 1430 - 000	101 - 5	FB4 - 1795 - 000	775 - 7	FB4 - 2078 - 000	320 - 22
FB4 - 1432 - 000	120 - 1	FB4 - 1797 - 000	775 - 8	FB4 - 2088 - 000	330 - 1
FB4 - 1433 - 000	120 - 2	FB4 - 1806 - 000	250 - 5	FB4 - 2090 - 000	330 - 2
FB4 - 1436 - 000	120 - 3		270 - 1	FB4 - 2093 - 000	330 - 3
FB4 - 1437 - 000	100 - 17		280 - 3	FB4 - 2094 - 000	330 - 4
FB4 - 1443 - 000	770 - 1	FB4 - 1820 - 020	640 - 5	FB4 - 2106 - 000	360 - 7
FB4 - 1447 - 000	107 - 6	FB4 - 1821 - 020	640 - 6	FB4 - 2113 - 000	360 - 8

D NUMERICAL INDEX

部品索引表

PART NUMBER	FIGURE & KEY NO.	PART NUMBER	FIGURE & KEY NO.	PART NUMBER	FIGURE & KEY NO.
FB4 - 2114 - 020	360 - 9	FB4 - 3762 - 000	315 - 2 6 A	FB5 - 0530 - 000	580 - 13
FB4 - 2121 - 000	360 - 10	FB4 - 3767 - 000	264 - 2	FB5 - 0532 - 000	101 - 7
FB4 - 2122 - 000	360 - 11	FB4 - 3772 - 000	315 - 19	FB5 - 0539 - 000	320 - 4 6
FB4 - 2124 - 000	360 - 12	FB4 - 3773 - 000	102 - 9	FB5 - 0553 - 000	231 - 2
FB4 - 2131 - 000	360 - 13	FB4 - 3774 - 000	316 - 8	FB5 - 1489 - 000	300 - 2 5
FB4 - 2132 - 000	360 - 14	FB4 - 3811 - 000	103 - 12	FB5 - 1840 - 000	105 - 5
FB4 - 2133 - 000	360 - 15	FB4 - 3814 - 000	102 - 10	FB5 - 1844 - 000	600 - 3 5
FB4 - 2135 - 000	360 - 16	FB4 - 3816 - 000	102 - 11	FB5 - 2063 - 000	311 - 3 2
FB4 - 2136 - 000	360 - 17	FB4 - 3817 - 000	102 - 12		312 - 2 9
FB4 - 2145 - 000	360 - 18	FB4 - 3822 - 000	102 - 13		313 - 2 3
FB4 - 2149 - 000	360 - 19	FB4 - 3823 - 000	102 - 14	FB5 - 2131 - 000	130 - 6
FB4 - 2150 - 000	360 - 20	FB4 - 3850 - 000	325 - 10	FB5 - 2164 - 000	130 - 7
FB4 - 2151 - 000	360 - 21	FB4 - 3851 - 000	325 - 11	FB5 - 2165 - 000	130 - 8
FB4 - 2152 - 000	360 - 2 2	FB4 - 3852 - 000	325 - 1 2	FB5 - 2168 - 000	130 - 9
FB4 - 2153 - 000	360 - 2 3	FB4 - 3853 - 000	325 - 2 1 A	FB5 - 2169 - 000	130 - 10
FB4 - 2155 - 000	360 - 2 4	FB4 - 3857 - 000	325 - 2 2 A	FB5 - 2170 - 000	130 - 1 1
FB4 - 2156 - 000	360 - 2 5	FB4 - 3858 - 000	325 - 1 3	FB5 - 2171 - 000	130 - 1 2
FB4 - 2159 - 000	360 - 2 6	FB4 - 3860 - 000	325 - 1 4	FB5 - 2172 - 000	130 - 1 3
	810 - 1 6	FB4 - 5005 - 000	130 - 5	FB5 - 2173 - 000	130 - 1 4
FB4 - 2164 - 000	360 - 2 7	FB4 - 5093 - 020	102 - 1 5	FB5 - 2174 - 000	926 - 1
FB4 - 2183 - 000	810 - 1 7	FB4 - 5253 - 000	300 - 2 4	FB5 - 2176 - 000	130 - 1 5
FB4 - 2191 - 000	810 - 1 8	FB4 - 5257 - 000	101 - 6	FB5 - 2177 - 000	130 - 1 6
FB4 - 2195 - 020	810 - 1 9	FB4 - 5267 - 000	303 - 1 3	FB5 - 2178 - 000	130 - 1 7
FB4 - 2196 - 020	810 - 2 0	FB4 - 5268 - 000	302 - 1 2	FB5 - 2179 - 000	130 - 1 8
FB4 - 2214 - 000	810 - 2 1		303 - 1 4	FB5 - 2180 - 000	130 - 1 9
FB4 - 2224 - 000	320 - 2 3	FB4 - 5297 - 000	100 - 2 9	FB5 - 2195 - 000	926 - 2
FB4 - 2225 - 000	320 - 2 4	FB4 - 5298 - 000	100 - 3 0	FB5 - 2394 - 000	580 - 1 4
FB4 - 2235 - 000	320 - 2 5	FB4 - 5305 - 000	550 - 9	FB5 - 2508 - 000	351 - 1 2
FB4 - 2236 - 000	320 - 2 6	FB4 - 5309 - 000	275 - 2 0	FB5 - 2515 - 000	580 - 1 5
FB4 - 2237 - 000	320 - 2 7	FB4 - 5310 - 000	275 - 2 1	FB5 - 2596 - 000	106 - 7
FB4 - 2238 - 000	320 - 2 8	FB4 - 5311 - 000	100 - 3 1	FB5 - 2598 - 000	600 - 3 6
FB4 - 2239 - 000	810 - 2 2	FB4 - 5335 - 000	104 - 1 8	FB5 - 2837 - 000	315 - 2 1
FB4 - 2254 - 000	320 - 2 9	FB4 - 6214 - 000	311 - 2 7	FB5 - 2838 - 000	315 - 2 2
FB4 - 2261 - 000	350 - 8	FB4 - 6227 - 000	311 - 2 8	FB5 - 2841 - 000	300 - 3 1 A
FB4 - 2262 - 000	350 - 9		312 - 2 5	FB5 - 3105 - 000	580 - 1 6
FB4 - 2263 - 000	350 - 10		313 - 2 0	FB5 - 3351 - 000	104 - 20
FB4 - 2268 - 000	351 - 3	FB4 - 7478 - 000	100 - 3 2		300 - 2 6
FB4 - 2270 - 000	351 - 4	FB4 - 7481 - 000	360 - 2 9	FB5 - 3366 - 000	302 - 1 4
FB4 - 2271 - 000	351 - 5	FB4 - 7486 - 000	360 - 30		303 - 1 6
FB4 - 2272 - 000	351 - 6	FB4 - 7833 - 000	103 - 1 3	FB5 - 3367 - 000	302 - 3 3 A
FB4 - 2284 - 000	351 - 7	FB4 - 7834 - 000	104 - 1 9	FB5 - 3370 - 000	303 - 3 7 A
FB4 - 2288 - 000	351 - 8	FB4 - 7835 - 000	311 - 2 9		302 - 1 5
FB4 - 2289 - 000	351 - 9		312 - 2 6		303 - 1 7
FB4 - 2293 - 000	351 - 10	FB4 - 7839 - 000	102 - 1 6	FB5 - 3395 - 000	351 - 1 3
FB4 - 2294 - 000	351 - 11	FB4 - 7840 - 000	315 - 2 0	FB5 - 3407 - 000	320 - 4 7
FB4 - 2297 - 000	320 - 30	FB4 - 7845 - 000	103 - 1 4	FB5 - 3410 - 000	351 - 1 4
FB4 - 2299 - 000	320 - 3 1	FB4 - 7846 - 000	108 - 7	FB5 - 3421 - 000	351 - 1 5
FB4 - 2300 - 000	320 - 3 2	FB4 - 7878 - 000	320 - 4 3	FB5 - 3569 - 000	302 - 1 6
FB4 - 2303 - 000	320 - 3 3	FB4 - 7882 - 000	100 - 3 3	FB5 - 3625 - 000	350 - 1 1
FB4 - 2305 - 020	320 - 3 4	FB4 - 7883 - 000	100 - 3 4	FB5 - 4010 - 000	900 - 1
FB4 - 2306 - 020	320 - 3 5	FB4 - 8012 - 000	600 - 2 7	FB5 - 4339 - 000	312 - 30
FB4 - 2307 - 020	320 - 3 6	FB4 - 8013 - 000	600 - 2 8	FB5 - 4346 - 000	215 - 1 6
FB4 - 2308 - 020	320 - 3 7	FB4 - 8014 - 000	600 - 2 9	FB5 - 4347 - 000	215 - 1 7
FB4 - 2310 - 000	320 - 3 8	FB4 - 8018 - 000	600 - 30	FB5 - 5606 - 000	302 - 1 7
FB4 - 2312 - 000	320 - 3 9	FB4 - 9026 - 000	275 - 2 2		303 - 1 8
FB4 - 2314 - 000	320 - 40	FB4 - 9027 - 000	275 - 2 3	FB5 - 5607 - 000	302 - 1 8
FB4 - 2317 - 000	320 - 4 1	FB4 - 9028 - 000	275 - 2 4		303 - 1 9
FB4 - 2322 - 020	325 - 9	FB4 - 9029 - 000	311 - 30	FB5 - 5608 - 000	302 - 1 9
FB4 - 2325 - 000	360 - 2 8		312 - 2 7		303 - 20
FB4 - 2327 - 000	320 - 4 2		313 - 2 1	FB5 - 5609 - 000	302 - 20
FB4 - 2333 - 000	130 - 3	FB4 - 9032 - 000	106 - 6		303 - 2 1
FB4 - 2343 - 000	130 - 4	FB4 - 9033 - 000	325 - 1 5	FB5 - 5620 - 000	312 - 3 1
FB4 - 2347 - 000	460 - 2	FB4 - 9034 - 000	105 - 4	FB5 - 5621 - 000	311 - 3 3
FB4 - 2358 - 000	210 - 1 1	FB4 - 9035 - 000	360 - 3 1	FB5 - 6586 - 000	311 - 3 4
FB4 - 2360 - 000	210 - 1 2	FB4 - 9043 - 000	311 - 3 1		312 - 3 2
FB4 - 2366 - 000	210 - 1 3		312 - 2 8		313 - 2 4
FB4 - 2376 - 000	210 - 1 4		313 - 2 2	FB5 - 6825 - 000	810 - 2 6
FB4 - 2384 - 000	210 - 1 5	FB4 - 9346 - 000	940 - 4	FB5 - 6833 - 000	810 - 2 7
FB4 - 2385 - 000	420 - 1 6	FB4 - 9355 - 000	580 - 1 1	FB5 - 6853 - 000	640 - 1 8 A
FB4 - 3118 - 000	101 - 20 A	FB4 - 9360 - 000	810 - 2 3	FB5 - 6856 - 000	600 - 3 7
FB4 - 3687 - 000	550 - 8	FB4 - 9361 - 000	810 - 2 4	FB5 - 6857 - 000	600 - 3 8
	570 - 1 3	FB4 - 9509 - 000	302 - 1 3	FB5 - 6862 - 000	103 - 1 5
	580 - 10		303 - 1 5	FB5 - 6868 - 000	600 - 3 9
FB4 - 3700 - 000	311 - 2 6	FB4 - 9511 - 000	770 - 3	FB5 - 6869 - 000	600 - 40
FB4 - 3723 - 020	260 - 3	FB4 - 9514 - 000	275 - 2 5	FB5 - 6877 - 000	275 - 2 6
FB4 - 3728 - 000	260 - 4	FB4 - 9515 - 000	325 - 1 6	FB5 - 6882 - 000	106 - 8
FB4 - 3729 - 000	260 - 5	FB4 - 9517 - 000	600 - 3 1	FB5 - 6884 - 000	106 - 9
FB4 - 3731 - 000	102 - 5	FB4 - 9518 - 000	600 - 3 2	FB5 - 6895 - 000	250 - 6
	102 - 6	FB4 - 9524 - 000	810 - 2 5	FB5 - 6916 - 000	100 - 3 5
FB4 - 3732 - 000	102 - 7	FB4 - 9525 - 000	600 - 3 3	FB5 - 6925 - 000	360 - 3 2
FB4 - 3741 - 020	102 - 8	FB4 - 9526 - 000	600 - 3 4	FB5 - 6930 - 000	810 - 2 8
FB4 - 3743 - 000	102 - 20 A	FB4 - 9797 - 020	320 - 4 4	FB5 - 6931 - 000	810 - 2 9
FB4 - 3747 - 000	315 - 1 6	FB4 - 9799 - 000	770 - 4	FB5 - 6932 - 000	810 - 30
FB4 - 3750 - 000	315 - 1 7	FB5 - 0527 - 000	320 - 4 5	FB5 - 6934 - 000	810 - 3 1
FB4 - 3759 - 000	315 - 1 8	FB5 - 0529 - 000	580 - 1 2	FB5 - 6935 - 000	810 - 3 2

D NUMERICAL INDEX

部品索引表

PART NUMBER	FIGURE & KEY NO.	PART NUMBER	FIGURE & KEY NO.	PART NUMBER	FIGURE & KEY NO.
FB5 - 6936 - 000	810 - 33	FB6 - 0513 - 000	311 - 36	FF2 - 2891 - 000	600 - 48
FB5 - 6941 - 000	810 - 34		312 - 34	FF2 - 5730 - 000	645 - 8
FB5 - 6944 - 000	810 - 35	FB6 - 0519 - 000	311 - 37	FF3 - 3330 - 000	550 - 10
FB5 - 6945 - 000	810 - 36		312 - 35	FF3 - 4190 - 000	311 - 40
FB5 - 6946 - 000	810 - 37		313 - 25		312 - 40
FB5 - 6948 - 000	810 - 38	FB6 - 0524 - 000	313 - 26		313 - 28
FB5 - 6951 - 000	810 - 39	FB6 - 0525 - 000	360 - 33	FF5 - 2173 - 000	210 - 20
FB5 - 6952 - 000	810 - 40	FB6 - 0528 - 000	100 - 49	FF5 - 2930 - 000	103 - 16
FB5 - 6957 - 000	810 - 41	FB6 - 0529 - 000	102 - 18	FF5 - 2939 - 000	315 - 23
FB5 - 6973 - 000	810 - 42	FB6 - 0534 - 000	360 - 34	FF5 - 2942 - 020	570 - 15
FB5 - 6974 - 000	350 - 12	FB6 - 0559 - 000	360 - 35	FF5 - 2943 - 000	315 - 24
FB5 - 6976 - 000	350 - 13	FB6 - 0560 - 000	360 - 36	FF5 - 2986 - 000	600 - 49
FB5 - 6980 - 000	303 - 22	FB6 - 0567 - 000	360 - 37	FF5 - 3063 - 030	311 - 41
FB5 - 6982 - 000	303 - 23	FB6 - 0575 - 000	360 - 38	FF5 - 3135 - 020	315 - 25
FB5 - 6986 - 000	303 - 24	FB6 - 0577 - 000	360 - 39	FF5 - 3220 - 000	311 - 42
FB5 - 6987 - 000	300 - 27	FB6 - 0579 - 000	360 - 40	FF5 - 3221 - 000	313 - 29
FB5 - 6988 - 000	100 - 36	FB6 - 0581 - 000	250 - 7	FF5 - 3228 - 000	312 - 41
FB5 - 6989 - 000	100 - 37	FB6 - 0582 - 000	101 - 17 A	FF5 - 5593 - 030	100 - 57
FB5 - 6992 - 000	100 - 38	FB6 - 0589 - 000	100 - 50	FF5 - 5594 - 030	100 - 58
FB5 - 6996 - 000	100 - 61 A	FB6 - 0590 - 000	100 - 51	FF5 - 5894 - 000	311 - 43
FB5 - 7001 - 000	100 - 39	FB6 - 0591 - 000	210 - 17	FF5 - 5895 - 000	311 - 44
FB5 - 7013 - 000	311 - 35	FB6 - 0598 - 000	130 - 21	FF5 - 5914 - 000	350 - 19
	312 - 33	FB6 - 0599 - 000	350 - 18	FF5 - 6000 - 000	320 - 58
FB5 - 7028 - 000	460 - 3	FB6 - 0603 - 000	100 - 52	FF5 - 6183 - 000	300 - 29
FB5 - 7029 - 000	460 - 4	FB6 - 0605 - 000	130 - 22	FF5 - 6189 - 000	300 - 30
FB5 - 7042 - 000	215 - 18	FB6 - 0606 - 000	130 - 23	FF5 - 6579 - 000	420 - 17
FB5 - 7048 - 000	105 - 6	FB6 - 0610 - 000	130 - 24	FF5 - 6581 - 000	430 - 11
FB5 - 7054 - 000	210 - 16	FB6 - 0615 - 000	311 - 38	FF5 - 6883 - 000	550 - 11
FB5 - 7075 - 000	320 - 48		312 - 36		580 - 19
FB5 - 7076 - 000	320 - 49		313 - 27	FF5 - 6884 - 000	550 - 12
FB5 - 7077 - 000	810 - 43	FB6 - 0617 - 000	130 - 25		580 - 20
FB5 - 7558 - 000	810 - 44	FB6 - 0623 - 000	360 - 41	FF5 - 6885 - 000	550 - 13
FB5 - 7559 - 000	810 - 45	FB6 - 0624 - 000	360 - 42		580 - 21
FB5 - 7560 - 000	810 - 46	FB6 - 0625 - 000	360 - 43	FF5 - 6889 - 000	311 - 45
FB5 - 7562 - 000	810 - 47	FB6 - 0776 - 000	100 - 53		312 - 42
FB5 - 7655 - 000	320 - 50	FB6 - 0782 - 000	900 - 3	FF5 - 6890 - 000	313 - 30
FB5 - 7656 - 000	320 - 51	FB6 - 0783 - 000	770 - 5	FF5 - 6904 - 000	311 - 46
FB5 - 7657 - 000	351 - 16	FB6 - 0784 - 000	107 - 7	FF5 - 6905 - 000	311 - 47
FB5 - 7660 - 000	810 - 48	FB6 - 2369 - 000	104 - 22	FF5 - 7540 - 000	313 - 31
FB5 - 7662 - 000	351 - 17	FB6 - 2370 - 000	640 - 15	FF5 - 7651 - 000	940 - 5
FB5 - 7663 - 000	351 - 18	FB6 - 2372 - 000	325 - 20	FF5 - 7655 - 000	103 - 17
FB5 - 7664 - 000	351 - 19	FB6 - 2373 - 000	320 - 56	FF5 - 7658 - 000	101 - 9
FB5 - 7666 - 000	350 - 14	FB6 - 2376 - 000	320 - 57	FF5 - 7662 - 000	101 - 10
FB5 - 7668 - 000	350 - 15	FB6 - 2377 - 000	311 - 39	FF5 - 7664 - 000	101 - 11
FB5 - 7671 - 000	320 - 52		312 - 37	FF5 - 7665 - 000	107 - 8
FB5 - 7672 - 000	320 - 53	FB6 - 2380 - 000	600 - 42	FF5 - 7667 - 000	102 - 19
FB5 - 7673 - 000	320 - 54	FB6 - 2385 - 000	600 - 43	FF5 - 7673 - 000	315 - 26
FB5 - 7674 - 000	351 - 22 A	FB6 - 2390 - 000	600 - 44	FF5 - 7674 - 000	315 - 27
FB5 - 7676 - 000	325 - 17	FB6 - 2397 - 000	100 - 54	FF5 - 7675 - 000	315 - 28
FB5 - 7677 - 000	351 - 22 B		100 - 55	FF5 - 7682 - 000	600 - 50
FB5 - 7678 - 000	351 - 22 C		360 - 44	FF5 - 7695 - 000	645 - 9
FB5 - 8482 - 000	900 - 2	FB6 - 2400 - 000	600 - 45	FF5 - 7698 - 000	640 - 16
FB5 - 8717 - 000	350 - 16	FB6 - 2402 - 000	600 - 46	FF5 - 7701 - 000	640 - 17
FB5 - 8718 - 000	351 - 22 D	FB6 - 2415 - 000	100 - 56	FF5 - 7705 - 000	550 - 14
FB5 - 8723 - 000	102 - 17	FB6 - 2416 - 000	100 - 56	FF5 - 7706 - 000	550 - 15
FB5 - 8729 - 000	350 - 17	FB6 - 2719 - 000	302 - 21	FF5 - 7715 - 000	275 - 28
FB5 - 8735 - 000	104 - 21		303 - 25	FF5 - 7717 - 000	215 - 21
FB5 - 8809 - 000	215 - 19	FB6 - 2720 - 000	600 - 47	FF5 - 7726 - 000	105 - 11
FB5 - 8810 - 000	215 - 20	FB6 - 2724 - 000	210 - 18	FF5 - 7734 - 000	360 - 45
FB5 - 8817 - 000	600 - 41	FB6 - 2725 - 000	210 - 19	FF5 - 7736 - 000	360 - 46
FB5 - 9351 - 000	300 - 28	FB6 - 2726 - 000	104 - 23	FF5 - 7737 - 020	360 - 47
FB5 - 9354 - 000	570 - 14	FB6 - 2727 - 000	104 - 24	FF5 - 7829 - 000	311 - 48
FB5 - 9648 - 000	580 - 17	FB6 - 2728 - 000	104 - 25		312 - 43
FB6 - 0397 - 000	100 - 40	FB6 - 2887 - 000	316 - 9		313 - 32
FB6 - 0403 - 000	100 - 41	FB6 - 4057 - 000	312 - 38	FF5 - 7830 - 000	311 - 49
FB6 - 0404 - 000	100 - 42	FB6 - 4059 - 000	312 - 39		312 - 44
FB6 - 0405 - 000	101 - 8	FC1 - 1117 - 000	251 - 2		313 - 33
FB6 - 0433 - 000	105 - 7	FC1 - 5049 - 000	302 - 22	FF5 - 7832 - 000	312 - 45
FB6 - 0439 - 000	105 - 8		303 - 26	FF5 - 7833 - 000	312 - 46
FB6 - 0442 - 000	100 - 43	FC1 - 5051 - 000	302 - 23	FF5 - 7840 - 000	313 - 34
FB6 - 0443 - 000	100 - 44		303 - 27	FF5 - 7845 - 000	320 - 59
FB6 - 0444 - 000	100 - 45	FC1 - 5052 - 000	302 - 24	FF5 - 7846 - 000	320 - 60
FB6 - 0445 - 000	275 - 27		303 - 28	FF5 - 7850 - 000	320 - 61
FB6 - 0446 - 000	100 - 46	FC1 - 5055 - 000	302 - 25	FF5 - 7860 - 000	810 - 49
FB6 - 0448 - 000	100 - 47		303 - 29	FF5 - 7872 - 000	325 - 21
FB6 - 0449 - 000	105 - 9	FC1 - 5056 - 000	302 - 26	FF5 - 7875 - 000	325 - 22
FB6 - 0450 - 000	105 - 10		303 - 30	FF5 - 7877 - 000	325 - 23
FB6 - 0454 - 000	130 - 20	FC1 - 5061 - 000	302 - 27	FF5 - 7878 - 000	325 - 24
FB6 - 0473 - 000	325 - 18		303 - 31	FF5 - 7880 - 000	320 - 62
FB6 - 0474 - 000	325 - 19	FC1 - 5080 - 000	302 - 28	FF5 - 7881 - 000	320 - 63
FB6 - 0480 - 000	320 - 55		303 - 32	FF5 - 7882 - 020	101 - 12
FB6 - 0484 - 000	330 - 5	FC1 - 5081 - 000	302 - 29	FF5 - 7883 - 000	210 - 21
FB6 - 0485 - 000	330 - 6		303 - 33	FF5 - 7884 - 000	120 - 5
FB6 - 0500 - 000	100 - 48	FC1 - 6853 - 000	194 - 1	FF5 - 7891 - 020	580 - 22
FB6 - 0502 - 000	580 - 18	FC1 - 7438 - 000	351 - 20	FF5 - 7938 - 000	210 - 22

D NUMERICAL INDEX

部品索引表

PART NUMBER	FIGURE & KEY NO.	PART NUMBER	FIGURE & KEY NO.	PART NUMBER	FIGURE & KEY NO.
FF5 - 7942 - 000	100 - 5 9	FF6 - 1849 - 000	100 - 6 6	FG6 - 2020 - 020	775 -
FF5 - 7944 - 000	320 - 6 4	FF6 - 1850 - 000	100 - 6 7	FG6 - 2023 - 000	101 - 2 0
FF5 - 7948 - 000	360 - 4 8	FF6 - 1851 - 000	810 - 5 2	FG6 - 2033 - 000	210 - 3 1
FF5 - 7949 - 000	360 - 4 9	FF6 - 1856 - 000	315 - 3 2	FG6 - 2036 - 060	420 -
FF5 - 8139 - 000	101 - 1 3	FF6 - 1858 - 000	360 - 5 8	FG6 - 2243 - 000	231 -
FF5 - 8140 - 000	316 - 1 0	FF6 - 1997 - 000	100 - 6 6	FG6 - 2291 - 020	945 -
FF5 - 8141 - 000	102 - 2 0	FF6 - 1998 - 000	100 - 6 6	FG6 - 2305 - 000	102 - 2 5
FF5 - 8147 - 000	102 - 2 1	FF6 - 1999 - 000	100 - 6 6	FG6 - 2326 - 000	420 - 1 9
FF5 - 8150 - 000	302 - 3 0	FF6 - 2001 - 000	100 - 6 7	FG6 - 2328 - 000	101 - 2 1
	303 - 3 4	FF6 - 2002 - 000	100 - 6 7	FG6 - 2330 - 000	101 - 2 2
FF5 - 8151 - 000	302 - 3 1	FF6 - 2003 - 000	100 - 6 7	FG6 - 2331 - 000	102 - 2 6
	303 - 3 5	FF9 - 1763 - 000	315 - 3 3	FG6 - 2334 - 000	104 - 2 9
FF5 - 8152 - 000	101 - 1 4	FF9 - 1764 - 000	315 - 3 4	FG6 - 2335 - 000	311 - 5 2
FF5 - 8157 - 000	315 - 2 9	FF9 - 1901 - 000	100 - 6 8	FG6 - 2340 - 000	460 - 5
FF5 - 8194 - 000	102 - 2 2	FF9 - 1909 - 000	210 - 2 4	FG6 - 2512 - 000	210 - 3 2
	103 - 1 8	FG1 - 3472 - 000	720 -	FG6 - 3568 - 000	600 - 5 3
	325 - 2 5	FG2 - 9195 - 000	305 - 1		B - J 2 7 2
FF5 - 8196 - 000	320 - 6 5	FG2 - 9812 - 000	305 - 2	FG6 - 3569 - 000	106 - 1 0
FF5 - 8200 - 000	360 - 5 0	FG3 - 1690 - 000	935 - 1		B - J 2 7 1
FF5 - 8201 - 000	360 - 5 1	FG3 - 2142 - 000	920 -		B - J 2 7 2
FF5 - 8202 - 000	360 - 5 2	FG3 - 2143 - 000	926 -	FG6 - 3570 - 000	251 - 3
FF5 - 8654 - 040	320 - 6 6	FG3 - 2144 - 000	926 - 3	FG6 - 3572 - 000	264 - 3
FF5 - 8655 - 000	275 - 2 9	FG3 - 2145 - 000	926 - 4	FG6 - 4380 - 000	430 -
FF5 - 8661 - 000	103 - 1 9	FG3 - 2146 - 000	130 - 3 0	FG6 - 6512 - 000	110 - 3
FF5 - 8732 - 000	275 - 3 0	FG3 - 2147 - 000	130 - 3 1	FG6 - 6853 - 000	900 - 4
FF5 - 8733 - 000	510 - 7	FG5 - 1957 - 000	107 - 9	FG6 - 6885 - 000	251 - 4
FF5 - 8736 - 000	320 - 6 7	FG5 - 1958 - 000	316 - 1 1	FG6 - 6902 - 000	210 - 3 5 A
FF5 - 8787 - 000	320 - 6 8	FG5 - 4449 - 050	261 -	FG6 - 6903 - 000	250 - 8
FF5 - 8796 - 000	325 - 2 6	FG5 - 8221 - 000	107 - 1 0	FG6 - 7185 - 000	570 - 1 8
FF5 - 8892 - 000	210 - 2 3	FG5 - 9419 - 000	305 - 1 B	FG6 - 7200 - 000	810 - 5 6
FF5 - 8895 - 030	103 - 2 0	FG6 - 1813 - 000	110 - 2	FG6 - 7201 - 000	106 - 1 1
FF5 - 9550 - 000	300 - 3 1		111 - 2		B - J 1 4
FF5 - 9551 - 000	315 - 3 0	FG6 - 1817 - 000	120 - 6		B - J 1 7
FF5 - 9552 - 000	570 - 1 6	FG6 - 1818 - 000	770 - 6	FG6 - 7202 - 000	215 - 2 3
FF5 - 9561 - 000	315 - 3 1	FG6 - 1819 - 000	770 - 7	FG6 - 7203 - 000	570 - 1 9
FF5 - 9784 - 000	311 - 5 0	FG6 - 1820 - 000	770 - 8	FG6 - 7204 - 000	600 - 5 4
	312 - 4 7	FG6 - 1822 - 000	210 - 3 6 D	FG6 - 7206 - 000	110 - 4
	313 - 3 5	FG6 - 1823 - 000	210 - 2 5		111 - 3
FF5 - 9791 - 000	302 - 3 2	FG6 - 1824 - 000	210 - 2 6	FG6 - 7207 - 000	110 - 5
FF5 - 9793 - 000	303 - 3 6	FG6 - 1826 - 000	215 - 2 2		111 - 4
FF5 - 9892 - 000	104 - 2 6	FG6 - 1827 - 000	210 - 2 7	FG6 - 7208 - 000	105 - 1 3
FF6 - 1013 - 000	302 - 3 3	FG6 - 1828 - 000	210 - 2 8	FG6 - 7211 - 000	106 - 1 2
FF6 - 1014 - 000	303 - 3 7	FG6 - 1839 - 000	360 - 5 9	FG6 - 7213 - 000	210 - 3 3
FF6 - 1016 - 000	600 - 5 1	FG6 - 1840 - 000	360 - 6 0	FG6 - 7214 - 000	270 - 2
FF6 - 1017 - 000	320 - 6 9	FG6 - 1841 - 000	360 - 6 1	FG6 - 7216 - 000	900 - 5
FF6 - 1019 - 000	300 - 3 2	FG6 - 1843 - 000	360 - 6 2	FG6 - 7217 - 000	900 - 6
FF6 - 1029 - 000	351 - 2 1	FG6 - 1853 - 000	600 - 5 2	FG6 - 7218 - 000	900 - 7
FF6 - 1031 - 000	570 - 1 7		B - J 1 7	FG6 - 7220 - 000	980 - 1
FF6 - 1034 - 000	300 - 3 3	FG6 - 1854 - 000	640 - 1 9	FG6 - 7221 - 000	105 - 1 4
FF6 - 1041 - 000	640 - 1 8	FG6 - 1858 - 000	550 - 1 6	FG6 - 7222 - 000	900 - 8
FF6 - 1046 - 000	351 - 2 2	FG6 - 1866 - 000	315 - 3 5	FG6 - 7223 - 000	210 - 3 5 B
FF6 - 1049 - 000	325 - 2 7	FG6 - 1867 - 000	102 - 2 4	FG6 - 7238 - 000	910 -
FF6 - 1051 - 000	300 - 3 4	FG6 - 1871 - 000	320 - 7 1	FG6 - 7239 - 000	910 - 4
FF6 - 1052 - 000	300 - 3 4	FG6 - 1872 - 000	325 - 2 9	FG6 - 7249 - 000	980 -
FF6 - 1053 - 000	325 - 2 8	FG6 - 1873 - 000	325 - 3 0	FG6 - 7256 - 000	970 -
FF6 - 1054 - 000	300 - 3 5	FG6 - 1874 - 000	325 - 3 1	FG6 - 7258 - 000	900 - 9
	302 - 3 4	FG6 - 1875 - 000	810 - 5 3	FG6 - 7260 - 000	210 - 3 4
	303 - 3 8		B - J 1 5	FG6 - 7264 - 000	960 -
FF6 - 1067 - 000	100 - 6 0	FG6 - 1876 - 000	320 - 7 2	FG6 - 7266 - 000	900 - 1 0
FF6 - 1082 - 000	810 - 5 0	FG6 - 1879 - 000	320 - 7 3	FG6 - 7268 - 000	105 - 1 5
FF6 - 1087 - 000	810 - 5 1	FG6 - 1880 - 000	810 - 5 4	FG6 - 7270 - 000	111 -
FF6 - 1333 - 000	300 - 3 6	FG6 - 1881 - 000	810 - 5 5	FG6 - 7271 - 000	111 -
FF6 - 1336 - 000	101 - 1 5	FG6 - 1882 - 000	910 - 2	FG6 - 7278 - 000	900 - 1 1
FF6 - 1498 - 000	130 - 2 6	FG6 - 1884 - 000	940 - 6	FG6 - 7281 - 000	900 - 1 2
FF6 - 1499 - 000	130 - 2 7	FG6 - 1885 - 000	940 - 7	FG6 - 7284 - 000	900 - 1 3
FF6 - 1501 - 000	101 - 1 6	FG6 - 1887 - 000	910 - 3	FG6 - 7294 - 000	120 -
FF6 - 1502 - 000	194 - 2	FG6 - 1888 - 000	231 - 3	FG6 - 7313 - 000	550 -
FF6 - 1509 - 000	320 - 7 0	FG6 - 1889 - 020	275 - 3 1	FG6 - 7319 - 000	111 -
FF6 - 1516 - 000	102 - 2 3	FG6 - 1891 - 000	645 - 1 0	FG6 - 7320 - 000	111 -
FF6 - 1519 - 000	360 - 5 3	FG6 - 1892 - 000	101 - 1 8	FG6 - 7327 - 000	270 -
FF6 - 1520 - 000	360 - 5 4	FG6 - 1893 - 000	210 - 2 9	FG6 - 7328 - 000	280 -
FF6 - 1521 - 000	360 - 5 5	FG6 - 1896 - 000	103 - 2 1	FG6 - 7332 - 000	210 - 3 5
FF6 - 1524 - 000	100 - 6 1	FG6 - 1898 - 000	190 - 1	FG6 - 7366 - 000	351 -
FF6 - 1526 - 000	100 - 6 2	FG6 - 1901 - 000	101 - 1 9	FG6 - 7376 - 000	302 -
FF6 - 1529 - 000	101 - 1 7	FG6 - 1904 - 000	107 - 1 1	FG6 - 7377 - 000	303 -
FF6 - 1530 - 000	130 - 2 8		B - J 1 1	FG6 - 7401 - 000	210 - 3 6
FF6 - 1531 - 000	100 - 6 3		B - J 1 5	FG6 - 7405 - 000	935 - 2
FF6 - 1532 - 000	100 - 6 4	FG6 - 1906 - 000	104 - 2 7	FG6 - 7424 - 000	570 -
FF6 - 1533 - 000	311 - 5 1	FG6 - 1941 - 000	104 - 2 8	FG6 - 7428 - 000	940 -
FF6 - 1534 - 000	312 - 4 8	FG6 - 1942 - 000	210 - 3 0	FG6 - 7429 - 000	600 - 5 5
FF6 - 1535 - 000	313 - 3 6	FG6 - 1943 - 000	420 - 1 8	FG6 - 7738 - 000	925 -
FF6 - 1536 - 000	360 - 5 6	FG6 - 1971 - 000	105 - 1 2	FG6 - 7745 - 000	810 - 5 7
FF6 - 1541 - 000	100 - 6 5	FG6 - 1987 - 000	195 -	FG6 - 7747 - 000	770 -
FF6 - 1542 - 000	130 - 2 9	FG6 - 1996 - 000	263 -	FG6 - 7748 - 000	810 - 5 8
FF6 - 1843 - 000	360 - 5 7	FG6 - 2011 - 000	645 -	FG6 - 7999 - 000	194 -

D NUMERICAL INDEX

部品索引表

PART NUMBER	FIGURE & KEY NO.	PART NUMBER	FIGURE & KEY NO.	PART NUMBER	FIGURE & KEY NO.
FG6 - 8005 - 000	110 -	FH2 - 6453 - 000	B - J 163	FH4 - 9181 - 000	940 - RA1
FG6 - 8006 - 000	320 -		B - J 164	FH6 - 0767 - 000	926 - LED909
FG6 - 8008 - 000	251 -		B - J 166		926 - LED910
FG6 - 8009 - 000	250 -	FH2 - 6480 - 000	B - J 152	FH6 - 0768 - 000	926 - LED907
FG6 - 8010 - 000	260 -		B - J 228		926 - LED908
FG6 - 8015 - 000	360 -	FH2 - 6552 - 000	110 - 6	FH6 - 0786 - 000	926 - VR901
FG6 - 8017 - 000	311 -		111 - 5	FH6 - 1135 - 000	550 - 17
FG6 - 8018 - 000	312 -		770 - 9		570 - 21
FG6 - 8019 - 000	313 -	FH2 - 6574 - 000	210 - 38		580 - 24
FG6 - 8024 - 000	275 -		B - J 162	FH6 - 1481 - 000	360 - 70
FG6 - 8025 - 000	130 -		B - J 852	FH6 - 1538 - 000	275 - 32
FG6 - 8026 - 000	130 -		B - J 1003	FH6 - 1541 - 000	231 - 4
FG6 - 8027 - 000	130 -	FH2 - 6756 - 000	900 - 16	FH6 - 1542 - 000	360 - 71
FG6 - 8032 - 000	325 -		B - J 1104	FH6 - 1543 - 000	645 - 11
FG6 - 8033 - 000	330 -		B - J 9202	FH6 - 1544 - 000	210 - 39
FG6 - 8041 - 000	350 -	FH2 - 6791 - 000	130 - 32	FH6 - 1545 - 000	190 - 2
FG6 - 8042 - 000	810 -		B - J 6801	FH6 - 1546 - 000	194 - 4
FG6 - 8043 - 000	810 -		B - J 7001		910 - 5
FG6 - 8576 - 000	190 -	FH2 - 6807 - 000	106 - 13	FH6 - 1547 - 000	210 - 40
FG6 - 8577 - 000	230 -	FH2 - 6842 - 000	130 - 33		215 - 24
FG6 - 8579 - 000	460 -	FH2 - 6877 - 000	110 - 7		600 - 58
FG6 - 8580 - 000	264 -	FH2 - 6898 - 000	210 - 36E		600 - 59
FG6 - 8583 - 000	985 -		B - J 1108	FH6 - 1548 - 000	320 - 76
FG6 - 8584 - 000	320 -		B - J 1503	FH6 - 1550 - 000	195 - 1
FG6 - 8585 - 000	360 - 63	FH2 - 6899 - 000	210 - 36F	FH6 - 1740 - 000	105 - 18
FG6 - 8588 - 000	320 -		B - J 1107	FH6 - 1877 - 000	105 - 19
FG6 - 8590 - 000	311 - 53		B - J 1502	FH6 - 1878 - 000	900 - 18
FG6 - 8591 - 000	312 - 49	FH2 - 6900 - 000	900 - 17	FH6 - 1886 - 000	210 - 41
FG6 - 8592 - 000	313 - 37		B - J 1302	FH6 - 1934 - 000	251 - 5
FG6 - 8593 - 000	360 - 64		B - J 1452	FH6 - 1935 - 000	250 - 9
FG6 - 8594 - 000	600 - 56	FH2 - 6901 - 000	111 - 6	FH6 - 1936 - 000	260 - 6
FG6 - 8595 - 000	600 - 57	FH2 - 6919 - 000	111 - 7	FH6 - 1937 - 000	320 - 77
FG6 - 8597 - 000	910 -	FH2 - 6920 - 000	111 - 8	FH6 - 1939 - 000	360 - 72
FG6 - 8598 - 000	910 -	FH2 - 6921 - 000	111 - 9	FH6 - 1940 - 000	360 - 73
FG6 - 8599 - 000	930 - 1	FH2 - 9231 - 000	985 - 1	FH6 - 1942 - 000	320 - 78
FG6 - 8601 - 000	460 - 6		B - J 731	FH6 - 1960 - 000	101 - 23
FG6 - 8604 - 000	107 - 12		B - J 732	FH6 - 1961 - 000	600 - 60
FG6 - 8605 - 000	311 - 54		B - J 733	FH6 - 3337 - 000	985 - R551
	312 - 50	FH2 - 9232 - 000	106 - 14		985 - R561
	313 - 38	FH2 - 9233 - 000	106 - 15		985 - R571
	360 - 65	FH2 - 9235 - 000	106 - 16		985 - R581
FG6 - 8609 - 000	930 - 2	FH2 - 9242 - 000	580 - 23		985 - R851
FG6 - 8614 - 000	900 - 14	FH3 - 0242 - 000	940 - T1		985 - R857
FG6 - 8616 - 000	360 - 66	FH3 - 0665 - 000	910 - CT301	FH6 - 3994 - 000	510 - 8
	B - J 322	FH3 - 0666 - 000	910 - CT111	FH6 - 5013 - 000	325 - 32
	B - J 323		910 - CT111	FH6 - 5014 - 000	264 - 5
	B - J 326		945 - T1002		311 - 55
	B - J 329	FH3 - 0688 - 000	910 - L501		312 - 51
	B - J 330	FH3 - 0744 - 000	910 - T301		320 - 79
	B - J 336	FH3 - 0766 - 000	985 - T601		360 - 74
	B - J 338	FH3 - 0830 - 000	985 - T701	FH6 - 5015 - 000	270 - 3
	B - J 340	FH3 - 0859 - 000	910 - T931	FH6 - 5016 - 000	264 - 6
	B - J 366	FH3 - 0879 - 000	945 - T1001	FH6 - 5017 - 000	270 - 4
	B - J 380	FH3 - 0881 - 000	945 - T1003	FH6 - 5043 - 000	230 - 3
	B - J 381	FH3 - 0888 - 000	910 - T901		264 - 7
	B - J 3601	FH3 - 0889 - 000	910 - L251		311 - 56
	B - J 3602	FH3 - 0890 - 000	910 - L351		312 - 52
	B - J 3603	FH3 - 0893 - 000	985 - T101		313 - 39
	B - J 3605		985 - T501	FH7 - 3347 - 000	420 - 21
	B - J 3607		985 - T801	FH7 - 3395 - 000	600 - 61
	B - J 3608	FH3 - 0894 - 000	985 - T301	FH7 - 4559 - 000	420 - 22
	B - J 3609		985 - T401	FH7 - 4585 - 000	305 - 3
FG6 - 8617 - 000	360 - 67	FH3 - 0936 - 000	960 - T1	FH7 - 4714 - 000	510 - 9
FG6 - 8618 - 000	360 - 68	FH3 - 0938 - 000	960 - L1	FH7 - 4715 - 000	510 - 9
FG6 - 8619 - 000	360 - 69		960 - L2	FH7 - 4719 - 000	810 - 59
FG6 - 8620 - 000	102 - 27	FH3 - 0961 - 000	925 - T1	FH7 - 4720 - 000	810 - 59
FG6 - 8621 - 000	320 - 74	FH3 - 5237 - 000	980 - T1	FH7 - 4723 - 000	810 - 60
FG6 - 8622 - 000	194 - 3	FH3 - 7195 - 000	910 - L 4	FH7 - 4724 - 000	810 - 60
FG6 - 8623 - 000	230 - 2	FH3 - 7202 - 000	945 - L1002	FH7 - 5702 - 000	311 - 57
	264 - 4	FH3 - 7203 - 000	945 - L1001	FH7 - 5827 - 000	312 - 53
FG6 - 8625 - 000	900 - 15	FH4 - 1380 - 000	920 - Q6822		313 - 40
FG6 - 8724 - 000	600 -	FH4 - 3882 - 000	970 - IC12	FH7 - 5836 - 000	320 - 80
FG6 - 8730 - 000	640 -	FH4 - 3883 - 000	970 - IC13	FH7 - 5837 - 000	320 - 81
FG6 - 8733 - 000	580 -	FH4 - 5904 - 000	970 - IC 2		360 - 75
FG6 - 8735 - 000	810 -	FH4 - 5905 - 000	970 - IC 3	FH7 - 5838 - 000	315 - 36
FG6 - 8736 - 000	315 -	FH4 - 6019 - 000	940 - 8	FH7 - 5840 - 000	645 - 12
FG6 - 8738 - 000	320 - 75	FH4 - 6040 - 000	910 - Q901	FH7 - 5844 - 000	320 - 82
FG6 - 9114 - 000	316 -	FH4 - 6104 - 000	930 - IC119	FH7 - 5845 - 000	320 - 83
FG9 - 3863 - 000	570 - 20	FH4 - 6123 - 000	930 - IC108	FH7 - 6253 - 000	120 - 7
FG9 - 3878 - 000	105 - 16		935 - IC 5	FH7 - 6327 - 000	105 - 20
FG9 - 3879 - 000	105 - 17	FH4 - 6135 - 000	935 - IC 4	FH7 - 6331 - 000	960 - RL1
FH2 - 6452 - 000	210 - 37	FH4 - 6136 - 000	935 - IC18	FH7 - 7196 - 020	360 - 76
	B - J 162	FH4 - 6154 - 000	970 - IC 5	FH7 - 7337 - 000	640 - 20
	B - J 163	FH4 - 6156 - 000	930 - IC107		645 - 13
FH2 - 6453 - 000	420 - 20	FH4 - 9157 - 000	985 - R206	FH7 - 7342 - 000	101 - 24

D NUMERICAL INDEX

部品索引表

PART NUMBER	FIGURE & KEY NO.	PART NUMBER	FIGURE & KEY NO.	PART NUMBER	FIGURE & KEY NO.
FH7 - 7394 - 000	102 - 2 8	FS2 - 9410 - 000	770 - 1 1	FS5 - 3610 - 000	280 - 6
FH7 - 7423 - 000	210 - 4 2	FS2 - 9428 - 000	302 - 3 5	FS5 - 3612 - 000	250 - 1 3
FH7 - 7424 - 000	210 - 4 3		303 - 3 9	FS5 - 3613 - 000	360 - 8 4
	210 - 4 4	FS3 - 0046 - 000	270 - 6	FS5 - 3615 - 000	320 - 9 9
FH7 - 7462 - 000	101 - 2 5	FS3 - 0098 - 000	275 - 3 5	FS5 - 3617 - 000	360 - 8 5
	101 - 2 6	FS3 - 0165 - 000	230 - 5	FS5 - 3889 - 000	270 - 8
	102 - 2 5 A		260 - 1 0	FS5 - 3890 - 000	250 - 1 4
	102 - 2 9	FS3 - 2044 - 000	107 - 1 4		280 - 7
	103 - 2 2	FS3 - 2053 - 000	810 - 6 8	FS5 - 3942 - 000	360 - 8 6
	210 - 4 5	FS3 - 2159 - 000	320 - 9 0	FS5 - 3943 - 000	360 - 8 7
	210 - 4 6	FS3 - 2887 - 000	600 - 6 3	FS5 - 3945 - 000	360 - 8 8
	231 - 5	FS4 - 0012 - 000	302 - 3 6	FS5 - 6329 - 000	320 - 1 0 0
	275 - 3 3		303 - 4 0	FS5 - 6487 - 000	250 - 1 5
	311 - 5 8	FS4 - 0014 - 000	261 - 5		320 - 1 0 1
	312 - 5 4		264 - 8		320 - 1 0 2
	313 - 4 1	FS4 - 0145 - 000	260 - 1 1		325 - 3 4
	315 - 3 7		261 - 6		360 - 8 9
	320 - 8 4	FS4 - 0157 - 000	270 - 7		810 - 7 1
	325 - 3 3	FS4 - 0160 - 000	302 - 3 7	FS5 - 6488 - 000	270 - 9
	360 - 7 7		303 - 4 1		280 - 8
	770 - 1 0	FS4 - 2048 - 000	320 - 9 1		320 - 1 0 3
	810 - 6 1	FS4 - 2136 - 000	302 - 3 8		360 - 9 0
FH7 - 7464 - 000	810 - 6 2		303 - 4 2	FS5 - 6574 - 000	640 - 2 2
FH7 - 7485 - 000	210 - 4 7	FS5 - 0338 - 000	311 - 6 1	FS5 - 6575 - 000	320 - 1 0 4
FH7 - 7574 - 000	110 - 8		312 - 5 7	FS5 - 6579 - 000	640 - 2 3
	111 - 1 0		313 - 4 5	FS5 - 6581 - 000	315 - 4 1
FN5 - 4002 - 000	940 - 9		360 - 7 9	FS5 - 6582 - 000	102 - 3 3
FN5 - 4009 - 000	215 - 2 5	FS5 - 0398 - 000	230 - 6		102 - 3 4
FS1 - 0542 - 000	320 - 8 5	FS5 - 0514 - 000	102 - 3 2	FS5 - 6583 - 000	810 - 7 2
FS1 - 1189 - 000	230 - 4		263 - 3	FS5 - 6684 - 000	210 - 5 0
	260 - 7		360 - 8 0	FS5 - 7128 - 000	107 - 2 1
	263 - 1	FS5 - 0532 - 000	300 - 3 7	FS5 - 8618 - 000	300 - 3 0 A
FS1 - 1202 - 000	645 - 1 4	FS5 - 0710 - 000	360 - 8 1		302 - 3 9
FS1 - 1401 - 000	350 - 2 0	FS5 - 0714 - 000	360 - 8 2		303 - 4 3
	360 - 7 8	FS5 - 1004 - 000	351 - 2 4	FS5 - 8619 - 000	300 - 3 1 B
FS1 - 1449 - 000	260 - 8	FS5 - 1372 - 000	350 - 2 2	FS5 - 8623 - 000	105 - 2 2
	810 - 6 3	FS5 - 1467 - 020	106 - 1 7		460 - 7
FS1 - 1503 - 000	645 - 1 5		320 - 9 2	FS5 - 9166 - 000	101 - 2 8
FS1 - 1508 - 000	320 - 8 6	FS5 - 1468 - 020	107 - 1 5	FS5 - 9210 - 000	320 - 1 0 5
FS1 - 1510 - 000	275 - 3 4	FS5 - 1474 - 000	320 - 9 3	FS5 - 9214 - 000	985 - 2
FS1 - 1512 - 000	311 - 5 9	FS5 - 1787 - 000	104 - 3 0	FS5 - 9216 - 000	101 - 2 9
	312 - 5 5	FS5 - 1796 - 000	275 - 3 6	FS5 - 9219 - 000	210 - 5 1
	313 - 4 2	FS5 - 1798 - 000	105 - 2 1	FS5 - 9221 - 000	360 - 9 1
FS1 - 1569 - 000	311 - 6 0	FS5 - 1800 - 000	600 - 6 4	FS5 - 9277 - 000	351 - 2 7
	312 - 5 6	FS5 - 1801 - 000	600 - 6 5	FS5 - 9282 - 000	107 - 1 1 B
	313 - 4 3	FS5 - 1802 - 000	275 - 3 7		107 - 2 2
	315 - 3 8	FS5 - 1803 - 000	320 - 9 4		107 - 2 3
	810 - 6 4	FS5 - 1804 - 000	107 - 1 6	FS5 - 9284 - 000	351 - 2 8
FS1 - 2834 - 000	810 - 6 5	FS5 - 2322 - 000	107 - 1 7	FS5 - 9398 - 000	770 - 1 2
FS1 - 9002 - 000	210 - 4 8	FS5 - 2323 - 020	107 - 1 8	FS5 - 9491 - 000	210 - 5 2
FS1 - 9009 - 000	430 - 1 2	FS5 - 2328 - 000	300 - 3 8	FS5 - 9619 - 000	810 - 7 3
FS1 - 9051 - 000	810 - 6 6	FS5 - 2650 - 000	300 - 3 9	FS5 - 9752 - 000	810 - 7 4
FS1 - 9199 - 000	350 - 2 1	FS5 - 2901 - 000	275 - 3 8	FS6 - 0048 - 000	311 - 6 3
	351 - 2 3	FS5 - 2907 - 020	320 - 9 5	FS6 - 0049 - 000	311 - 6 4
FS2 - 0088 - 000	720 - 1 2	FS5 - 2911 - 000	312 - 5 8	FS6 - 0051 - 000	311 - 6 5
FS2 - 0089 - 000	720 - 1 3	FS5 - 2914 - 000	312 - 5 9	FS6 - 0053 - 020	264 - 9
FS2 - 0090 - 000	720 - 1 4	FS5 - 2919 - 000	313 - 4 6		311 - 6 6
FS2 - 0091 - 000	720 - 1 5	FS5 - 2921 - 000	100 - 6 9		312 - 6 1
FS2 - 0441 - 000	320 - 8 7		100 - 7 0		313 - 4 8
FS2 - 0485 - 000	270 - 5	FS5 - 2922 - 000	100 - 7 1	FS6 - 0055 - 000	261 - 7
FS2 - 0544 - 000	313 - 4 4		100 - 7 2	FS6 - 0056 - 000	260 - 1 3
FS2 - 0566 - 000	102 - 3 0	FS5 - 2928 - 000	120 - 8		261 - 8
	102 - 3 1	FS5 - 2940 - 000	810 - 6 9		263 - 4
FS2 - 0875 - 000	645 - 1 6	FS5 - 2944 - 000	351 - 2 5		270 - 1 0
FS2 - 1014 - 000	640 - 2 1	FS5 - 2946 - 000	350 - 2 3		311 - 6 7
FS2 - 1256 - 000	810 - 6 7	FS5 - 2947 - 000	320 - 9 6		312 - 6 2
FS2 - 1357 - 000	315 - 3 9	FS5 - 2949 - 000	320 - 9 7		325 - 3 5
FS2 - 1463 - 000	600 - 6 2	FS5 - 2950 - 000	810 - 7 0	FS6 - 0062 - 000	260 - 1 4
FS2 - 2001 - 000	720 - 1 6	FS5 - 2953 - 020	350 - 2 4	FS6 - 0070 - 000	360 - 9 2
FS2 - 2002 - 000	720 - 1 7	FS5 - 2958 - 000	101 - 2 7	FS6 - 0081 - 000	320 - 1 0 6
FS2 - 2036 - 020	510 - 1 0	FS5 - 2959 - 000	280 - 5	FS6 - 0096 - 000	260 - 1 5
FS2 - 2058 - 000	720 - 1 8	FS5 - 2964 - 000	107 - 1 1 A	FS6 - 0103 - 000	810 - 7 5
FS2 - 2551 - 000	580 - 2 5	FS5 - 2965 - 000	107 - 1 9	FS6 - 0105 - 000	810 - 7 6
FS2 - 3494 - 020	260 - 9		107 - 2 0	FS6 - 0106 - 000	810 - 7 7
	261 - 4	FS5 - 2967 - 000	320 - 9 8	FS6 - 0115 - 000	550 - 1 8
	263 - 2	FS5 - 2978 - 000	250 - 1 1		570 - 2 2
FS2 - 3495 - 000	250 - 1 0	FS5 - 2982 - 000	351 - 2 6		580 - 2 6
	280 - 4	FS5 - 3177 - 000	316 - 1 2	FS6 - 0121 - 000	600 - 6 6
FS2 - 9001 - 000	215 - 2 6	FS5 - 3314 - 000	360 - 8 3	FS6 - 0134 - 000	810 - 7 8
	320 - 8 8	FS5 - 3331 - 000	315 - 4 0	FS6 - 0136 - 000	600 - 6 7
FS2 - 9267 - 000	210 - 4 9	FS5 - 3333 - 000	311 - 6 2	FS6 - 0138 - 000	600 - 6 8
	320 - 8 9		312 - 6 0	FS6 - 0145 - 000	360 - 9 3
	107 - 1 3		313 - 4 7	FS6 - 0557 - 000	360 - 9 4
FS2 - 9327 - 000	103 - 2 3	FS5 - 3337 - 020	260 - 1 2	FS6 - 0857 - 000	640 - 2 4
FS2 - 9343 - 000	103 - 2 4	FS5 - 3609 - 000	250 - 1 2	FS6 - 0899 - 000	320 - 1 0 7

D NUMERICAL INDEX

部品索引表

PART NUMBER	FIGURE & KEY NO.	PART NUMBER	FIGURE & KEY NO.	PART NUMBER	FIGURE & KEY NO.
FS6 - 0972 - 000	600 - 69	FS6 - 2991 - 000	600 - 79	FS7 - 8287 - 000	300 - 48
FS6 - 0973 - 000	600 - 70	FS6 - 2992 - 000	360 - 105	FS7 - 8289 - 000	316 - 13
FS6 - 0975 - 000	600 - 71	FS6 - 2993 - 020	320 - 119	FS7 - 8290 - 000	100 - 67A
FS6 - 0976 - 000	600 - 72	FS6 - 2994 - 000	600 - 80	FS7 - 8291 - 000	100 - 66A
FS6 - 0977 - 000	600 - 73	FS6 - 2996 - 000	311 - 72	FS7 - 8318 - 000	100 - 66A
FS6 - 0978 - 000	600 - 74	FS6 - 2997 - 000	312 - 64	FS7 - 8319 - 000	100 - 66A
FS6 - 0979 - 000	640 - 25	FS6 - 2998 - 000	275 - 43	FS7 - 8320 - 000	100 - 66A
FS6 - 0980 - 000	640 - 26	FS6 - 2999 - 000	260 - 17	FS7 - 8322 - 000	100 - 67A
FS6 - 0981 - 000	640 - 27	FS6 - 4243 - 000	104 - 34	FS7 - 8323 - 000	100 - 67A
FS6 - 0982 - 000	640 - 28		104 - 35	FS7 - 8324 - 000	100 - 67A
FS6 - 0983 - 000	640 - 29	FS6 - 8386 - 000	320 - 58A	FS8 - 8194 - 000	100 - 77
FS6 - 0984 - 000	640 - 30	FS6 - 8387 - 000	320 - 65A	FY1 - 0883 - 000	550 - 19
FS6 - 0985 - 000	640 - 31	FS6 - 8399 - 000	600 - 81	FY1 - 1157 - 000	810 - 89
FS6 - 0988 - 000	645 - 17	FS6 - 8411 - 000	300 - 44	FY9 - 3014 - 000	020 - 1
FS6 - 0989 - 000	645 - 18	FS6 - 8703 - 000	320 - 120	FY9 - 3040 - 020	020 - 2
FS6 - 0990 - 000	645 - 19	FS6 - 8704 - 000	360 - 55A	FY9 - 3041 - 000	020 - 3
FS6 - 0991 - 000	320 - 108	FS6 - 8706 - 000	316 - 13	RA1 - 7807 - 000	316 - 14
FS6 - 0992 - 000	320 - 109	FS6 - 8707 - 000	316 - 13	RH2 - 5283 - 000	B - J 47
FS6 - 0993 - 000	320 - 110	FS6 - 8708 - 000	316 - 13		B - J 112
FS6 - 0994 - 000	320 - 111	FS6 - 8709 - 000	316 - 10A		B - J 246
FS6 - 0995 - 000	320 - 112	FS6 - 8820 - 000	105 - 22		B - J 16
FS6 - 0996 - 000	320 - 113		460 - 7	RH2 - 5339 - 000	985 - T202
FS6 - 0997 - 000	320 - 114	FS6 - 8821 - 000	101 - 30	RH3 - 0071 - 000	960 - SK1
FS6 - 0998 - 000	320 - 115	FS6 - 8822 - 000	101 - 30	RH6 - 3434 - 000	960 - SK2
FS6 - 0999 - 000	320 - 116	FS6 - 8823 - 000	100 - 75		960 - SK3
FS6 - 1025 - 000	600 - 75	FS6 - 8980 - 000	300 - 45		960 - SK4
FS6 - 2098 - 000	130 - 34	FS6 - 8981 - 000	302 - 42	RS6 - 0057 - 000	251 - 7
FS6 - 2667 - 000	104 - 31	FS6 - 8982 - 000	300 - 46	RY1 - 1502 - 000	580 - 27
	104 - 32	FS6 - 8990 - 000	300 - 47	VD5 - 0323 - 501	930 - FU103
FS6 - 2668 - 000	311 - 68	FS6 - 8992 - 000	100 - 76		930 - FU104
FS6 - 2670 - 000	311 - 69	FS7 - 0002 - 000	320 - 121		930 - FU105
FS6 - 2678 - 000	311 - 70	FS7 - 0006 - 000	320 - 122	VD7 - 0642 - 001	105 - 15A
	312 - 63	FS7 - 0007 - 000	810 - 80	VD7 - 0646 - 301	910 - FU101
	313 - 49	FS7 - 0008 - 000	810 - 81	VD7 - 1621 - 001	945 - FU1002
FS6 - 2691 - 000	300 - 40	FS7 - 0010 - 000	251 - 6	VD7 - 1622 - 001	210 - 30A
FS6 - 2692 - 000	300 - 41	FS7 - 0011 - 000	106 - 18		925 - FU1
FS6 - 2693 - 000	300 - 42	FS7 - 0012 - 000	250 - 16	VD7 - 1624 - 000	945 - FU1001
FS6 - 2694 - 000	300 - 43	FS7 - 0014 - 000	250 - 17	VD7 - 1832 - 501	960 - FU2
FS6 - 2737 - 000	210 - 53	FS7 - 0015 - 000	270 - 11	VS1 - 0279 - 003	B - J 335
FS6 - 2742 - 000	311 - 71	FS7 - 0016 - 000	250 - 18	VS1 - 0279 - 004	B - J 2
FS6 - 2748 - 000	600 - 76	FS7 - 0017 - 000	250 - 19	VS1 - 0279 - 005	B - J 1
FS6 - 2749 - 000	600 - 77	FS7 - 0018 - 000	250 - 20	VS1 - 0842 - 002	B - CN 1
FS6 - 2750 - 000	640 - 32	FS7 - 0019 - 000	250 - 21	VS1 - 0842 - 003	B - J 6804
FS6 - 2751 - 000	640 - 33	FS7 - 0020 - 000	280 - 10	VS1 - 0842 - 006	B - J 108
FS6 - 2752 - 000	280 - 9	FS7 - 0021 - 000	280 - 11	VS1 - 0842 - 014	B - J 6805
FS6 - 2756 - 000	775 - 9	FS7 - 0022 - 000	280 - 12	VS1 - 0842 - 015	B - J 6802
FS6 - 2759 - 000	940 - 10	FS7 - 0023 - 000	280 - 13	VS1 - 5057 - 002	101 - 19A
FS6 - 2760 - 000	770 - 13	FS7 - 0024 - 000	280 - 14		110 - 2A
FS6 - 2761 - 000	210 - 54	FS7 - 0025 - 000	280 - 15		111 - 2A
FS6 - 2763 - 000	275 - 39	FS7 - 0026 - 000	280 - 16		120 - 9
FS6 - 2764 - 000	275 - 40	FS7 - 0027 - 000	775 - 10		230 - 7
FS6 - 2769 - 000	360 - 95	FS7 - 0033 - 000	264 - 10		251 - 4A
FS6 - 2770 - 000	360 - 96	FS7 - 0034 - 000	264 - 11		264 - 3A
FS6 - 2771 - 000	360 - 97	FS7 - 0035 - 020	260 - 18		264 - 12
FS6 - 2772 - 000	360 - 98	FS7 - 0036 - 000	260 - 19		270 - 2A
FS6 - 2773 - 000	360 - 99	FS7 - 0039 - 000	315 - 45		270 - 13
FS6 - 2774 - 000	275 - 41	FS7 - 0040 - 000	315 - 46		275 - 31A
FS6 - 2776 - 000	260 - 16	FS7 - 0041 - 000	315 - 47		311 - 52A
FS6 - 2777 - 000	360 - 100	FS7 - 0043 - 000	275 - 44		311 - 53A
FS6 - 2825 - 000	102 - 35	FS7 - 0044 - 000	275 - 45		312 - 49A
FS6 - 2826 - 000	100 - 73	FS7 - 0048 - 000	600 - 82		313 - 37A
	100 - 74	FS7 - 0050 - 000	600 - 83		320 - 124
FS6 - 2828 - 000	102 - 36	FS7 - 0051 - 000	275 - 46		320 - 125
FS6 - 2830 - 000	360 - 101	FS7 - 0072 - 000	270 - 12		325 - 29A
FS6 - 2831 - 000	360 - 102	FS7 - 0662 - 000	303 - 46		360 - 59A
FS6 - 2832 - 000	360 - 103	FS7 - 0891 - 000	810 - 82		550 - 20
FS6 - 2833 - 000	320 - 117	FS7 - 0893 - 000	810 - 83		550 - 21
FS6 - 2847 - 000	104 - 33	FS7 - 0894 - 000	810 - 84		570 - 23
FS6 - 2885 - 000	351 - 29	FS7 - 0895 - 000	810 - 85		580 - 28
FS6 - 2886 - 000	351 - 30	FS7 - 0896 - 000	250 - 22		600 - 56A
FS6 - 2887 - 000	275 - 42	FS7 - 0897 - 000	250 - 23		600 - 85
FS6 - 2888 - 000	102 - 37	FS7 - 0898 - 000	250 - 24		645 - 10A
FS6 - 2889 - 000	102 - 38	FS7 - 0899 - 000	320 - 123		810 - 55A
FS6 - 2892 - 000	315 - 42	FS7 - 0901 - 000	325 - 36		B - J 48
FS6 - 2893 - 000	315 - 43	FS7 - 2057 - 000	315 - 48		B - J 104
FS6 - 2894 - 000	210 - 55	FS7 - 2319 - 000	350 - 25		B - J 105
FS6 - 2980 - 000	360 - 104	FS7 - 2523 - 000	810 - 86		B - J 111
FS6 - 2981 - 000	600 - 78	FS7 - 2524 - 000	810 - 87		B - J 141
FS6 - 2982 - 000	320 - 118	FS7 - 2530 - 000	810 - 88		B - J 143
FS6 - 2983 - 000	302 - 40	FS7 - 2531 - 000	250 - 25		B - J 186
	303 - 44	FS7 - 2532 - 000	104 - 36		B - J 190
FS6 - 2984 - 000	302 - 41	FS7 - 2533 - 000	313 - 50		B - J 196
	303 - 45	FS7 - 2902 - 000	600 - 84		B - J 200
FS6 - 2985 - 000	315 - 44	FS7 - 5687 - 000	303 - 47		B - J 207
FS6 - 2990 - 000	810 - 79	FS7 - 8109 - 000	210 - 36G		B - J 217

D NUMERICAL INDEX

部品索引表

PART NUMBER	FIGURE & KEY NO.	PART NUMBER	FIGURE & KEY NO.	PART NUMBER	FIGURE & KEY NO.	
VS1 - 5057 - 002	B - J 230	VS1 - 5057 - 003	B - J 261	VS1 - 6302 - 002	B - J 248	
	B - J 231		B - J 265		B - J 1027	
	B - J 234		B - J 294		B - J 1722	
	B - J 242		B - J 303		B - J 1715	
	B - J 245		B - J 334		B - J 520	
	B - J 251		B - J 336		B - J 721	
	B - J 252		B - J 338		B - J 791	
	B - J 253		B - J 340		B - J 1058	
	B - J 254		B - J 342		B - J 1305	
	B - J 255		B - J 363		B - J 2030	
	B - J 264		B - J 364		B - J 2031	
	B - J 271		B - J 381		B - J 165	
	B - J 282		B - J 383		B - J 722	
	B - J 283		B - J 901		B - J 741	
	B - J 289		B - J 2270		B - J 783	
	B - J 293		VS1 - 5057 - 004		B - J 1101	
	B - J 301		101 - 18A		B - J 1501	
	B - J 306		105 - 24		B - J 1712	
	B - J 307		107 - 10A		B - J 1720	
	B - J 313		215 - 22A		B - J 1102	
	B - J 320		313 - 37B		B - J 1723	
	B - J 321		320 - 73B		B - J 763	
	B - J 331		600 - 54A		B - J 1714	
	B - J 332		B - J 116		B - J 1721	
	B - J 333		B - J 130		B - J 1020	
	B - J 362		B - J 146		B - J 1716	
	B - J 365		B - J 204		B - J 164	
	B - J5031		B - J 257		B - J 507	
	B - J5032		B - J 266		B - J 167	
	VS1 - 5057 - 003		101 - 19B		B - J 291	B - J 314
			101 - 22A		B - J 317	B - J 503
			102 - 39		B - J 2B	B - J 518
			103 - 21A		B - J 151	B - J 1110
			104 - 37		VS1 - 5057 - 005	B - J 290
			105 - 23		VS1 - 5057 - 006	B - J 502
			107 - 24		210 - 26A	B - J 516
			190 - 1A		215 - 22B	107 - 25
			194 - 3A		231 - 3A	320 - 128
195 - 2		360 - 66A	B - J 158			
210 - 25A		810 - 55C	B - J 197			
210 - 27A		940 - 7A	B - J 281			
210 - 28A		B - J 108	B - J 305			
210 - 56		B - J 168	B - J 509			
215 - 27		B - J 211	B - J 513			
315 - 35A		B - J 213	B - J 515			
316 - 15		B - J 214	B - J 517			
320 - 71A		B - J 258	B - J 1019			
320 - 73A		B - J 268	B - J 1109			
320 - 126		210 - 35C	B - J 121			
320 - 127		270 - 2B	B - J 229			
360 - 59B		275 - 47	B - J 504			
360 - 60A		325 - 29B	B - J 506			
360 - 62A		770 - 7A	B - J 511			
360 - 67A		B - J 172	B - J 514			
360 - 68A		B - J 198	B - J 1453			
600 - 86		B - J 239	B - J 512			
600 - 87		B - J 243	107 - 26			
645 - 10B		B - J 249	B - J 322			
770 - 8A		B - J 250	B - J 505			
810 - 55B		VS1 - 5057 - 007	B - J 510			
B - J 101		311 - 53B	B - J 519			
B - J 113		312 - 49B	B - J 407			
B - J 114		B - J 235	B - J 1461			
B - J 118		B - J 286	B - J 405			
B - J 119		B - J 350	B - J 1018			
B - J 120		VS1 - 5057 - 008	B - J 7002			
B - J 127		360 - 59C	107 - 27			
B - J 129	B - J 330	320 - 129				
B - J 133	B - J 49	B - J 180				
B - J 136	B - J 224	B - J 508				
B - J 137	B - J 152	B - J 216				
B - J 139	B - J 240	B - J 177				
B - J 140	B - J 228	B - J 326				
B - J 142	B - J 23	B - J 346				
B - J 144	B - J 42	B - J 347				
B - J 175	B - J 43	B - J 1021				
B - J 191	B - J 46	B - J 1728				
B - J 205	B - J 56	B - J 276				
B - J 209	B - J 271	B - J 278				
B - J 210	B - J 28	B - J 280				
B - J 222	B - J 48	B - J 298				
B - J 225	B - J 245	B - J 328				
B - J 227	B - J 244	B - J 343				
B - J 241	B - J 334	B - J 351				
B - J 256	B - J 108	B - J 355				
	VS1 - 5824 - 002	B - J 243				
	VS1 - 5824 - 003	B - CN902				
	VS1 - 5824 - 006	B - CN901				
	VS1 - 5824 - 007	B - J 51				
	VS1 - 6023 - 014					
	VS1 - 6023 - 015					
	VS1 - 6302 - 002					
	VS1 - 6302 - 003					
	VS1 - 6302 - 004					
	VS1 - 6302 - 005					
	VS1 - 6302 - 006					
	VS1 - 6302 - 008					
	VS1 - 6302 - 009					
	VS1 - 6302 - 011					
	VS1 - 6302 - 012					
	VS1 - 6302 - 013					
	VS1 - 6302 - 015					
	VS1 - 6304 - 003					
	VS1 - 6313 - 008					
	VS1 - 6313 - 010					
	VS1 - 6313 - 011					
	VS1 - 6313 - 012					
	VS1 - 6313 - 013					
	VS1 - 6313 - 014					
	VS1 - 6313 - 015					
	VS1 - 6313 - 016					
	VS1 - 6313 - 017					
	VS1 - 6313 - 018					
	VS1 - 6313 - 020					
	VS1 - 6314 - 002					
	VS1 - 6314 - 003					
	VS1 - 6314 - 004					

D NUMERICAL INDEX

部品索引表

PART NUMBER	FIGURE & KEY NO.	PART NUMBER	FIGURE & KEY NO.	PART NUMBER	FIGURE & KEY NO.
VS1 - 6314 - 004	B - J 359 B - J 366 B - J 401 B - J 523 B - J 529 B - J1061 B - J1113 B - J5029 B - J9203	VS1 - 6318 - 004	900 - 5A B - J 343 B - J 366 B - J 401 B - J5029	VS1 - 6321 - 002	B - J 293 B - J 301 B - J 306 B - J 313 B - J 320 B - J 321 B - J 331 B - J 332 B - J 333 B - J 362 B - J 365 B - J5031 B - J5032
VS1 - 6314 - 005	B - J 408 B - J 409 B - J3701 B - J5030	VS1 - 6318 - 005	600 - 88 900 - 6A B - J 408 B - J5030	VS1 - 6321 - 003	B - J 101 B - J 102 B - J 103 B - J 113 B - J 114 B - J 115 B - J 118 B - J 120 B - J 122 B - J 127 B - J 128 B - J 129 B - J 132 B - J 133 B - J 136 B - J 137 B - J 139 B - J 140 B - J 142 B - J 144 B - J 145 B - J 147 B - J 156 B - J 157 B - J 159 B - J 169 B - J 171 B - J 174 B - J 175 B - J 182 B - J 184 B - J 185 B - J 191 B - J 194 B - J 199 B - J 205 B - J 208 B - J 209 B - J 210 B - J 222 B - J 223 B - J 225 B - J 226 B - J 227 B - J 232 B - J 233 B - J 236 B - J 237 B - J 241 B - J 256 B - J 259 B - J 260 B - J 261 B - J 262 B - J 265 B - J 269 B - J 270 B - J 284 B - J 285 B - J 292 B - J 294 B - J 295 B - J 296 B - J 303 B - J 304 B - J 308 B - J 309 B - J 315 B - J 316 B - J 318 B - J 319 B - J 327
VS1 - 6314 - 006	B - J 135 B - J 155 B - J 192 B - J1304	VS1 - 6318 - 006	210 - 28B 810 - 56A 910 - 3A B - J 135 B - J 155 B - J 192		
VS1 - 6314 - 007	B - J 173 B - J 526	VS1 - 6318 - 007	900 - 6B B - J 173 B - J 344		
VS1 - 6314 - 008	B - J 344 B - J 507	VS1 - 6318 - 008	VS1 - 6318 - 009		
VS1 - 6314 - 009	B - J 402 B - J1006	VS1 - 6318 - 010	900 - 5B B - J 402		
VS1 - 6314 - 010	B - J 167 B - J 187 B - J 314 B - J 503 B - J 518 B - J1024 B - J1110 B - J1719	VS1 - 6318 - 011	810 - 55D B - J 187 900 - 6C B - J 404 B - J 138 B - J 403 B - J 124		
VS1 - 6314 - 011	B - J 290 B - J 404 B - J 502 B - J1023 B - J9001	VS1 - 6318 - 013	VS1 - 6318 - 014		
VS1 - 6314 - 012	B - J 516 B - J1112	VS1 - 6318 - 014	VS1 - 6319 - 020		
VS1 - 6314 - 013	107 - 28 320 - 130 B - J 138 B - J 158 B - J 197 B - J 281 B - J 305 B - J 403 B - J 509 B - J 513 B - J 515 B - J 517 B - J1109	VS1 - 6319 - 022	313 - 37C B - J 167 B - J 314 101 - 31 B - J 290		
VS1 - 6314 - 014	B - J 121 B - J 124 B - J 229 B - J 504 B - J 506 B - J 511 B - J 514 B - J1453 B - J 512	VS1 - 6319 - 026	B - J 158 B - J 281 B - J 305 312 - 65 900 - 6D B - J 121 B - J 229 B - J 407 B - J 405 B - J 230 B - J 283 B - J 307 B - J 119 B - J 170 B - J 188 B - J 189 B - J 287 B - J 311 B - J2270		
VS1 - 6314 - 015	107 - 29	VS1 - 6319 - 028	B - J 211 B - J 48 B - J 104 B - J 105 B - J 111 B - J 125 B - J 141 B - J 143 B - J 149 B - J 150 B - J 186 B - J 190 B - J 195 B - J 196 B - J 200 B - J 206 B - J 207 B - J 217 B - J 230 B - J 231 B - J 234 B - J 242 B - J 251 B - J 252 B - J 253 B - J 254 B - J 255 B - J 263 B - J 264 B - J 267 B - J 271 B - J 282 B - J 289		
VS1 - 6314 - 016	B - J 322 B - J 505 B - J 510 B - J 519 B - J 723 B - J1303	VS1 - 6319 - 034	VS1 - 6319 - 036		
VS1 - 6314 - 017	B - J 407 B - J1461	VS1 - 6319 - 036	VS1 - 6320 - 002		
VS1 - 6314 - 018	B - J 405 B - J7002	VS1 - 6320 - 002	B - J 283 B - J 307 B - J 119 B - J 170 B - J 188 B - J 189 B - J 287 B - J 311 B - J2270		
VS1 - 6314 - 020	107 - 30 320 - 131 B - J 180 B - J 508	VS1 - 6320 - 003	B - J 230 B - J 283 B - J 307 B - J 119 B - J 170 B - J 188 B - J 189 B - J 287 B - J 311 B - J2270		
VS1 - 6318 - 002	270 - 2C B - J 216	VS1 - 6320 - 006	B - J 119 B - J 170 B - J 188 B - J 189 B - J 287 B - J 311 B - J2270		
VS1 - 6318 - 003	210 - 35D 360 - 59D B - J 177 B - J 326 B - J 346 B - J 347	VS1 - 6321 - 002	B - J 211 B - J 48 B - J 104 B - J 105 B - J 111 B - J 125 B - J 141 B - J 143 B - J 149 B - J 150 B - J 186 B - J 190 B - J 195 B - J 196 B - J 200 B - J 206 B - J 207 B - J 217 B - J 230 B - J 231 B - J 234 B - J 242 B - J 251 B - J 252 B - J 253 B - J 254 B - J 255 B - J 263 B - J 264 B - J 267 B - J 271 B - J 282 B - J 289		
VS1 - 6318 - 004	215 - 22C 360 - 64A				

D NUMERICAL INDEX

部品索引表

PART NUMBER	FIGURE & KEY NO.	PART NUMBER	FIGURE & KEY NO.	PART NUMBER	FIGURE & KEY NO.
WS3 - 5358 - 000	B - J 243	WS4 - 0219 - 000	B - J 45	XA9 - 0626 - 000	325 - 38
	B - J 244	WS4 - 0220 - 000	B - J 21		351 - 31
	B - J 245		B - J 40	XA9 - 0628 - 000	100 - 82
	B - J 334		B - J 41		102 - 41
WS3 - 5365 - 000	B - J 109	WT1 - 0579 - 000	B - J 16		102 - 42
WS3 - 5419 - 000	B - J 47	WT1 - 0580 - 000	110 - 11		103 - 25
	B - J 112		111 - 13		103 - 26
	B - J 246	WT2 - 0184 - 000	102 - 40		104 - 39
WS3 - 5472 - 000	B - J 1	WT2 - 5041 - 000	305 - 4		104 - 40
	B - J 26	WT2 - 5178 - 000	104 - 29A		104 - 41
WS3 - 5473 - 000	B - J 26		210 - 27B		104 - 42
WS3 - 5569 - 000	B - J 51		313 - 37D		105 - 25
	B - J 165		550 - 22		105 - 26
	B - J 247	WT2 - 5189 - 000	315 - 50		105 - 27
	B - J 248	WT2 - 5546 - 000	107 - 41		106 - 23
	B - J 721	WT2 - 5565 - 000	101 - 19C		108 - 8
	B - J 722		105 - 13A		108 - 9
	B - J 741		106 - 11A		195 - 3
	B - J 763		107 - 42		210 - 59
	B - J 791		194 - 5		230 - 8
	B - J 1101		231 - 6		231 - 7
	B - J 1501		250 - 8A		250 - 26
	B - J 1723		313 - 37E		251 - 8
	B - J 2030		320 - 137		260 - 20
	B - J 2031		360 - 66B		261 - 9
WS3 - 5571 - 000	B - J 164		600 - 89		263 - 5
WS3 - 5596 - 000	B - J 228		645 - 10C		264 - 13
	B - J 240		770 - 8B		270 - 14
WS3 - 5598 - 000	B - J 32	WT8 - 0053 - 000	970 - 1		280 - 17
	B - J 35	X62 - 5133 - 000	B - J 1091		300 - 51
	B - J 37	X62 - 7921 - 000	775 - 11		300 - 52
WS3 - 5607 - 000	107 - 38	X71 - 9310 - 000	600 - 90		305 - 5
	107 - 39		640 - 34		311 - 77
	107 - 40		645 - 20		312 - 69
	B - J 180	XA1 - 1160 - 207	600 - 501		313 - 51
	B - J 197	XA1 - 6260 - 409	510 - 501		315 - 51
	B - J 322	XA9 - 0034 - 000	580 - 29		315 - 52
WS3 - 5609 - 000	320 - 136	XA9 - 0189 - 000	190 - 3		320 - 139
	B - J 180	XA9 - 0207 - 000	106 - 19		320 - 140
	B - J 197		106 - 20		325 - 39
WS3 - 5610 - 000	110 - 9		106 - 21		350 - 27
	111 - 11	XA9 - 0228 - 000	550 - 23		351 - 32
WS3 - 5612 - 000	111 - 12		580 - 30	XA9 - 0629 - 000	360 - 110
WS3 - 5613 - 000	110 - 10	XA9 - 0249 - 000	360 - 106		100 - 83
	111 - 12	XA9 - 0253 - 000	325 - 37		100 - 84
WS3 - 5680 - 000	B - J 32	XA9 - 0265 - 000	107 - 43		100 - 85
	B - J 35		215 - 28		107 - 44
	B - J 37		311 - 74	XA9 - 0630 - 000	101 - 33
	B - J 50		312 - 66		103 - 27
	B - J 520		935 - 3		104 - 43
	B - J 783	XA9 - 0266 - 000	130 - 36		105 - 28
	B - J 1020	XA9 - 0271 - 000	210 - 57		107 - 45
	B - J 1027		312 - 67	XA9 - 0633 - 000	311 - 78
	B - J 1058	XA9 - 0384 - 000	106 - 22		312 - 70
	B - J 1102	XA9 - 0385 - 000	460 - 8		325 - 40
	B - J 1305	XA9 - 0425 - 000	430 - 13	XA9 - 0643 - 000	100 - 86
	B - J 1712	XA9 - 0427 - 000	215 - 29		101 - 34
	B - J 1714	XA9 - 0465 - 000	900 - 23		102 - 43
	B - J 1715	XA9 - 0520 - 000	210 - 58		103 - 28
	B - J 1716	XA9 - 0591 - 000	130 - 37		104 - 44
	B - J 1720		300 - 49		105 - 29
	B - J 1721		311 - 75		106 - 24
	B - J 1722		570 - 24		107 - 46
WS3 - 5719 - 000	B - J 50	XA9 - 0592 - 000	360 - 107		107 - 47
WS3 - 5720 - 000	B - J 51	XA9 - 0596 - 000	104 - 38		108 - 10
	B - J 323		130 - 38		210 - 60
	B - J 324		420 - 23		311 - 79
	B - J 325		570 - 25		312 - 71
	B - J 380	XA9 - 0605 - 000	100 - 78		320 - 141
	B - J 382		100 - 79		460 - 9
	B - J 2030		275 - 50		940 - 11
WS4 - 0217 - 000	B - J 14		300 - 50	XA9 - 0670 - 000	130 - 40
	B - J 18		302 - 43	XA9 - 0685 - 000	302 - 44
	B - J 20		303 - 48		303 - 49
	B - J 25		311 - 76	XA9 - 0721 - 000	100 - 87
	B - J 34		312 - 68		300 - 53
	B - J 40		320 - 138		302 - 45
	B - J 41		330 - 7		303 - 50
WS4 - 0218 - 000	B - J 21		360 - 108	XA9 - 0739 - 000	110 - 12
	B - J 45		360 - 109		111 - 14
WS4 - 0219 - 000	B - J 18		600 - 91	XA9 - 0774 - 000	107 - 48
	B - J 19	XA9 - 0606 - 000	100 - 80	XA9 - 0807 - 000	810 - 90
	B - J 20	XA9 - 0615 - 000	100 - 81	XA9 - 0813 - 000	251 - 9
	B - J 25		130 - 39	XA9 - 0828 - 000	900 - 24
	B - J 34	XA9 - 0625 - 000	350 - 26	XA9 - 0836 - 000	900 - 25

D NUMERICAL INDEX

部品索引表

PART NUMBER	FIGURE & KEY NO.	PART NUMBER	FIGURE & KEY NO.	PART NUMBER	FIGURE & KEY NO.
XA9 - 0836 - 000	900 - 2 6	XB1 - 2300 - 609	600 - 5 0 3	XB1 - 2402 - 009	900 - 5 0 4
XA9 - 0870 - 000	215 - 3 0		810 - 5 0 2	XB1 - 2402 - 509	275 - 5 0 6
XA9 - 0899 - 000	360 - 1 1 1		940 - 5 0 1	XB1 - 2403 - 009	210 - 5 0 9
XA9 - 0908 - 000	315 - 5 3		940 - 5 0 2		910 - 5 0 3
	320 - 1 4 2	XB1 - 2300 - 809	320 - 5 0 4	XB1 - 2403 - 509	105 - 5 0 5
	360 - 1 1 2		600 - 5 0 4	XB1 - 2404 - 009	320 - 5 1 0
XA9 - 0915 - 000	103 - 2 9		645 - 5 0 3	XB1 - 2500 - 606	110 - 5 0 4
	550 - 2 4		600 - 5 0 5		111 - 5 0 4
	580 - 3 1	XB1 - 2301 - 007	210 - 5 0 4	XB1 - 3400 - 606	130 - 5 0 4
		XB1 - 2301 - 207	550 - 5 0 3	XB2 - 4300 - 607	210 - 5 1 0
XA9 - 0924 - 000	103 - 3 0	XB1 - 2301 - 209	420 - 5 0 2	XB2 - 7300 - 407	640 - 5 0 4
XA9 - 0925 - 000	810 - 9 1		460 - 5 0 1	XB2 - 7300 - 607	325 - 5 0 2
XA9 - 0940 - 000	130 - 4 1		110 - 5 0 1		550 - 5 0 5
	320 - 1 4 3		111 - 5 0 1		580 - 5 0 2
XA9 - 0962 - 000	251 - 1 0	770 - 5 0 1		600 - 5 0 9	
XA9 - 0965 - 000	210 - 6 1	570 - 5 0 3	XB2 - 7400 - 606	110 - 5 0 5	
XA9 - 1030 - 000	250 - 2 7	550 - 5 0 4		111 - 5 0 5	
	260 - 2 1	320 - 5 0 5		130 - 5 0 5	
	320 - 1 4 4	570 - 5 0 4		210 - 5 1 1	
	325 - 4 1	103 - 5 0 2	360 - 5 0 7		
XA9 - 1090 - 000	106 - 2 5	103 - 5 0 3	460 - 5 0 3		
XA9 - 1091 - 000	106 - 2 6	103 - 5 0 4	770 - 5 0 3		
	215 - 3 1	104 - 5 0 1	930 - 5 0 1		
XA9 - 1092 - 000	210 - 6 2	104 - 5 0 2	XB2 - 7400 - 806	320 - 5 1 1	
XA9 - 1131 - 000	107 - 4 9	104 - 5 0 3		XB2 - 8300 - 607	420 - 5 0 3
XA9 - 1207 - 000	900 - 2 7	305 - 5 0 1		XB2 - 8300 - 609	600 - 5 1 0
XA9 - 1208 - 000	900 - 2 8	320 - 5 0 6		XB2 - 8300 - 805	360 - 5 0 8
XA9 - 1278 - 000	106 - 2 7	810 - 5 0 3	XB2 - 8300 - 809	420 - 5 0 4	
XA9 - 1331 - 000	103 - 3 1	100 - 5 0 1	XB2 - 8400 - 809	275 - 5 0 7	
XB1 - 1200 - 405	275 - 5 0 1	101 - 5 0 2		510 - 5 0 4	
XB1 - 2200 - 409	302 - 5 0 1	107 - 5 0 2	XB2 - 8401 - 007	105 - 5 0 6	
	303 - 5 0 1	110 - 5 0 2		105 - 5 0 7	
XB1 - 2230 - 809	101 - 5 0 1	111 - 5 0 2		XB2 - 8401 - 009	320 - 5 1 2
	120 - 5 0 1	316 - 5 0 1		810 - 5 0 7	
XB1 - 2231 - 009	250 - 5 0 1	107 - 5 0 3	XB2 - 8401 - 209	810 - 5 0 8	
	275 - 5 0 2	275 - 5 0 4	XB3 - 6300 - 800	107 - 5 0 4	
XB1 - 2260 - 407	320 - 5 0 1	302 - 5 0 2		120 - 5 0 2	
XB1 - 2300 - 402	640 - 5 0 1	303 - 5 0 3	XB3 - 6400 - 805	105 - 5 0 8	
XB1 - 2300 - 407	311 - 5 0 1	900 - 5 0 3	XB3 - 6401 - 000	130 - 5 0 6	
	312 - 5 0 1	102 - 5 0 4	XB4 - 5400 - 805	194 - 5 0 1	
	313 - 5 0 1	103 - 5 0 5	XB4 - 5401 - 006	100 - 5 0 2	
	320 - 5 0 2	103 - 5 0 6	XB4 - 7300 - 509	600 - 5 1 1	
	570 - 5 0 1	103 - 5 0 7	XB4 - 7300 - 607	300 - 5 0 3	
XB1 - 2300 - 409	210 - 5 0 1	104 - 5 0 4		300 - 5 0 4	
	311 - 5 0 2	210 - 5 0 5	XB4 - 7300 - 609	101 - 5 0 4	
	312 - 5 0 2	210 - 5 0 6		316 - 5 0 2	
	315 - 5 0 1	215 - 5 0 1	XB4 - 7300 - 809	210 - 5 1 2	
	325 - 5 0 1	275 - 5 0 5		320 - 5 1 3	
	350 - 5 0 1	300 - 5 0 2		360 - 5 0 9	
	360 - 5 0 1	302 - 5 0 3		640 - 5 0 5	
	360 - 5 0 2	303 - 5 0 4		645 - 5 0 4	
	420 - 5 0 1	311 - 5 0 4	XB4 - 7301 - 209	360 - 5 1 0	
	430 - 5 0 1	312 - 5 0 4		720 - 5 0 1	
	640 - 5 0 2	313 - 5 0 3	XB4 - 7301 - 609	320 - 5 1 4	
	645 - 5 0 1	315 - 5 0 2	XB4 - 7303 - 007	215 - 5 0 3	
	645 - 5 0 2	320 - 5 0 7	XB4 - 7303 - 009	210 - 5 1 3	
	810 - 5 0 1	320 - 5 0 8		600 - 5 1 2	
XB1 - 2300 - 506	107 - 5 0 1	350 - 5 0 2		600 - 5 1 3	
XB1 - 2300 - 602	600 - 5 0 2	360 - 5 0 3	XB4 - 7400 - 809	107 - 5 0 5	
XB1 - 2300 - 603	550 - 5 0 1	360 - 5 0 4	XB5 - 6401 - 609	231 - 5 0 1	
XB1 - 2300 - 604	640 - 5 0 3	460 - 5 0 2	XB6 - 2300 - 408	302 - 5 0 4	
XB1 - 2300 - 605	130 - 5 0 1	510 - 5 0 3		303 - 5 0 5	
XB1 - 2300 - 607	130 - 5 0 2	600 - 5 0 6		810 - 5 0 9	
	210 - 5 0 2	600 - 5 0 7	XB6 - 2400 - 509	311 - 5 0 5	
	900 - 5 0 1	770 - 5 0 2		312 - 5 0 5	
	900 - 5 0 2	810 - 5 0 4		320 - 5 1 5	
	910 - 5 0 1	940 - 5 0 3		360 - 5 1 1	
	910 - 5 0 2	940 - 5 0 4	XB6 - 2400 - 608	264 - 5 0 1	
XB1 - 2300 - 609	102 - 5 0 1	985 - 5 0 1	XB6 - 2400 - 609	325 - 5 0 3	
	102 - 5 0 2	105 - 5 0 2	XB6 - 2401 - 008	260 - 5 0 1	
	102 - 5 0 3	101 - 5 0 3	XB6 - 7300 - 405	900 - 5 0 5	
	103 - 5 0 1	130 - 5 0 3	XB6 - 7300 - 409	305 - 5 0 2	
	105 - 5 0 1	810 - 5 0 5		430 - 5 0 2	
	210 - 5 0 3	105 - 5 0 3	XB6 - 7300 - 609	210 - 5 1 4	
	275 - 5 0 3	360 - 5 0 5		350 - 5 0 3	
	300 - 5 0 1	810 - 5 0 6		420 - 5 0 5	
	303 - 5 0 2	210 - 5 0 7		550 - 5 0 6	
	311 - 5 0 3	105 - 5 0 4		810 - 5 1 0	
	312 - 5 0 3	210 - 5 0 8	XB6 - 7300 - 809	275 - 5 0 8	
	313 - 5 0 2	215 - 5 0 2	XB6 - 7400 - 609	105 - 5 0 9	
	320 - 5 0 3	320 - 5 0 9		210 - 5 1 5	
	351 - 5 0 1	600 - 5 0 8		215 - 5 0 4	
	510 - 5 0 2	110 - 5 0 3		305 - 5 0 3	
	550 - 5 0 2	111 - 5 0 3		320 - 5 1 6	
	570 - 5 0 2	360 - 5 0 6		600 - 5 1 4	
	580 - 5 0 1				

D NUMERICAL INDEX

部品索引表

PART NUMBER	FIGURE & KEY NO.	PART NUMBER	FIGURE & KEY NO.	PART NUMBER	FIGURE & KEY NO.
XB6 - 7401 - 609	510 - 505	XD2 - 1100 - 502	325 - 507	XD3 - 2200 - 102	315 - 509
XB7 - 2100 - 309	320 - 517		350 - 505		320 - 533
XB7 - 2200 - 409	810 - 511		360 - 514	XD3 - 2200 - 122	102 - 514
XD1 - 1103 - 137	320 - 518		600 - 518		102 - 515
XD1 - 1103 - 139	640 - 506		640 - 508		102 - 516
	645 - 505		645 - 507		250 - 504
XD1 - 1103 - 633	107 - 506		720 - 502		263 - 503
XD1 - 1104 - 132	311 - 506		770 - 505		264 - 503
XD1 - 1104 - 133	107 - 507		810 - 515		270 - 503
XD1 - 1104 - 135	101 - 505	XD2 - 1100 - 602	320 - 524		280 - 506
XD1 - 1104 - 138	770 - 504	XD2 - 1100 - 642	102 - 509		311 - 515
XD1 - 1104 - 139	360 - 512		102 - 510		312 - 513
XD1 - 1105 - 235	105 - 510		102 - 511		313 - 514
XD1 - 1105 - 239	105 - 511		105 - 512		315 - 510
XD1 - 1106 - 218	102 - 505		120 - 503		320 - 534
XD1 - 1106 - 221	645 - 506		210 - 516		360 - 517
XD1 - 1106 - 222	640 - 507		210 - 517		810 - 520
	810 - 512		230 - 501	XD3 - 2200 - 142	250 - 505
XD1 - 1106 - 223	102 - 506		250 - 503		260 - 503
XD1 - 1106 - 235	107 - 508		251 - 501		261 - 502
	600 - 515		260 - 502		263 - 504
XD1 - 1108 - 212	325 - 504		261 - 501		270 - 504
XD1 - 1108 - 219	263 - 501		263 - 502		275 - 513
XD1 - 1108 - 221	215 - 505		264 - 502		280 - 507
XD1 - 1108 - 222	280 - 501		270 - 502		320 - 535
XD1 - 1108 - 223	313 - 504		275 - 511		325 - 509
XD1 - 1108 - 226	313 - 505		280 - 504		330 - 503
XD1 - 1108 - 229	360 - 513		302 - 507		360 - 518
XD1 - 1108 - 235	300 - 505		303 - 509	XD3 - 2200 - 162	230 - 502
XD1 - 1108 - 239	302 - 505		311 - 511		250 - 506
	303 - 506		312 - 509		260 - 504
XD1 - 2100 - 307	550 - 507		313 - 509		261 - 503
XD1 - 3100 - 307	107 - 509		320 - 525		263 - 505
	130 - 507		320 - 526		264 - 504
XD1 - 3100 - 805	108 - 501		320 - 527		320 - 536
XD1 - 4200 - 502	110 - 506		320 - 528		330 - 504
	111 - 506		325 - 508		360 - 519
XD2 - 1100 - 172	320 - 519		330 - 501	XD3 - 2200 - 182	250 - 507
XD2 - 1100 - 242	231 - 502		360 - 515		360 - 520
	311 - 507		430 - 503		775 - 502
	312 - 506		430 - 504	XD3 - 2200 - 202	320 - 537
	313 - 506		600 - 519	XD3 - 2300 - 122	275 - 514
	320 - 520		645 - 508	XD3 - 2300 - 142	250 - 508
	350 - 504		775 - 501		260 - 505
	550 - 508		810 - 516	XD3 - 2300 - 182	260 - 506
	570 - 505		320 - 529	XD3 - 2300 - 202	320 - 538
	580 - 503	XD2 - 1100 - 802	330 - 502	XD3 - 2300 - 322	320 - 539
	810 - 513		600 - 520	XD9 - 0104 - 000	302 - 46
XD2 - 1100 - 322	275 - 509		810 - 517		303 - 51
	280 - 502	XD2 - 1200 - 902	810 - 518	XF2 - 1611 - 080	360 - 113
	311 - 508	XD2 - 2100 - 302	275 - 512	XF2 - 1612 - 680	360 - 114
	313 - 507	XD2 - 2100 - 502	351 - 503	XF9 - 0393 - 000	316 - 16
	315 - 503	XD2 - 2100 - 602	645 - 509	XF9 - 0502 - 000	315 - 54
	315 - 504	XD2 - 2100 - 802	311 - 512	XF9 - 0525 - 000	311 - 80
	320 - 521		312 - 510		312 - 72
	325 - 505		313 - 510		313 - 52
	600 - 516		320 - 530	XF9 - 0533 - 000	106 - 28
	810 - 514		600 - 521	XF9 - 0663 - 000	360 - 115
XD2 - 1100 - 372	311 - 509	XD2 - 2101 - 002	640 - 509	XF9 - 0680 - 000	210 - 63
	312 - 507	XD2 - 2300 - 202	420 - 506	XF9 - 0723 - 000	303 - 52
XD2 - 1100 - 402	104 - 505		430 - 505	XG2 - 8012 - 355	360 - 116
	302 - 506	XD2 - 2300 - 242	351 - 504	XG3 - 6012 - 405	102 - 44
	303 - 507	XD2 - 2300 - 402	100 - 503		102 - 45
	325 - 506	XD2 - 2300 - 602	600 - 522		320 - 145
	351 - 502	XD2 - 3100 - 102	640 - 510	XG9 - 0018 - 000	210 - 64
	600 - 517	XD2 - 3100 - 202	106 - 501	XG9 - 0111 - 000	600 - 48 A
XD2 - 1100 - 502	102 - 507	XD3 - 0300 - 082	311 - 513		600 - 92
	102 - 508		312 - 511	XG9 - 0120 - 000	640 - 35
	104 - 506	XD3 - 1200 - 102	313 - 511	XG9 - 0143 - 000	600 - 51 A
	104 - 507		315 - 506		600 - 93
	104 - 508		320 - 531	XG9 - 0175 - 000	275 - 51
	107 - 510		302 - 508	XG9 - 0192 - 000	360 - 117
	108 - 502	XD3 - 1200 - 122	303 - 510	XG9 - 0208 - 000	261 - 10
	250 - 502		315 - 507	XG9 - 0211 - 000	312 - 73
	270 - 501		102 - 512		320 - 146
	275 - 510	XD3 - 1200 - 142	102 - 513		320 - 147
	280 - 503		320 - 532		360 - 118
	300 - 506	XD3 - 1300 - 082	360 - 516		775 - 12
	303 - 508		313 - 512		810 - 92
	311 - 510	XD3 - 1300 - 102	810 - 519	XG9 - 0224 - 000	104 - 45
	312 - 508	XD3 - 1300 - 142	315 - 508		104 - 46
	313 - 508	XD3 - 2200 - 082	280 - 505	XG9 - 0248 - 000	106 - 29
	315 - 505	XD3 - 2200 - 102	311 - 514	XG9 - 0249 - 000	102 - 46
	320 - 522		312 - 512		230 - 9
	320 - 523		313 - 513		260 - 22

D NUMERICAL INDEX

部品索引表

PART NUMBER	FIGURE & KEY NO.	PART NUMBER	FIGURE & KEY NO.	PART NUMBER	FIGURE & KEY NO.
XG9 - 0249 - 000	263 - 6 264 - 14 270 - 15 360 - 119				
XG9 - 0250 - 000	102 - 47 102 - 48 102 - 49 250 - 28 260 - 23 270 - 16 280 - 18 312 - 74 320 - 148 320 - 149 320 - 150 330 - 8 360 - 120 600 - 94				
XG9 - 0291 - 000	360 - 121				
XG9 - 0302 - 000	104 - 47 104 - 48				
XG9 - 0307 - 000	510 - 11				
XG9 - 0350 - 000	280 - 19				
XG9 - 0362 - 000	360 - 122				
XG9 - 0366 - 000	810 - 93				
XG9 - 0385 - 000	275 - 52				
XG9 - 0395 - 000	270 - 17				
XG9 - 0406 - 000	810 - 94				
XG9 - 0407 - 000	311 - 81 312 - 75 313 - 53				
XG9 - 0421 - 000	810 - 95				
XG9 - 0439 - 000	302 - 47 303 - 53				
XG9 - 0447 - 000	810 - 96				
XG9 - 0472 - 000	325 - 42				
XH9 - 0006 - 000	210 - 65				
XH9 - 0082 - 000	302 - 48 303 - 54				
XH9 - 0090 - 000	275 - 53				
XH9 - 0110 - 000	900 - 29				
XZ9 - 0251 - 000	120 - 11				
XZ9 - 0367 - 000	108 - 11				
XZ9 - 0407 - 000	316 - 17				
XZ9 - 0472 - 000	275 - 54				
XZ9 - 0503 - 000	900 - 30				

Prepared by
OFFICE IMAGING PRODUCTS QUALITY ASSURANCE CENTER

CANON INC.
Printed in U.S.A.

REVISION 0 [AUG. 2001]

5-1, Hakusan 7-chome, Toride-city, Ibaraki 302-8501, Japan

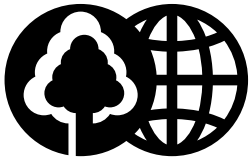

This publication is
printed on 100%
recycled paper.

Canon